



Craft Brew 850 Reverse Osmosis Systems Manual



Craft Brew Water, Inc

1336 Moorpark RD, Unit 239

Thousand Oaks, CA 91360

805-777-7037

Brewing Water

850 GPD Reverse Osmosis System

Specification Sheet



Craft Brew 850 GPD is a compact unit designed to provide productivity, automatic operation and low maintenance. The 850 come loaded with options that are standard on all Craft Brew Reverse Osmosis Systems. Blending Valve to control your incoming brewing water, pressure switch or float switch controlled, waste recycle stainless steel needle valve and the final stage UV protection.

Standard Features

Controller: Integrated Aquatrol controller provides automatic operation for optimum performance.

- Low Pressure Switch
- Contactor
- Level Switch
- Manual -automatic selector switch
- TDS sensor to monitor the water quality

Membrane Housing: 4" x 21" Stainless Steel

RO Membrane: (1) 4" x 21"

Pump: Brass Rotary vane type (coupled to 1725 RPM motor)

incoming Solenoid Valve: Brass 120v 3/8"

Flow Meter: Panel Mount 0.1-1 GPM

Pressure Gauges: 100 & 300 psi Glycerin filled

Waste and Recycle Valve: 316 Stainless Steel Needle Valve

Filter Housings: (3) NSF 10"

Pre-filters:

- (1) 2.5" x 10" Polyspun 5 Micron Sediment
- (1) 2.5" x 10" 5 Micron Carbon Block

Post filter (1) 2.5" x 10" 5 Micron Carbon Block

Frame: Electrostatic Powder Coated

Installation Kit



Specifications

Production: 850 GPD*

Membrane: 4" x 21" (1)

Operating Pressure: 100-150 psi

Capacity Rotary Pump: 100 gph

System Dimension: 26" x 23" x 20"

Weight: 70lbs

Electrical Power Supply: 120V/60 Hz



Craft Brew Water, Inc
284 Green Lea Pl, Thousand Oaks Ca 91361
805-777-7037

Installing UV on to Craft Brew 850 Reverse Osmosis System



The Box Marked Polaris



**Contains : Clips,
UV Bulb
Stainless UV
and Connection Tube**

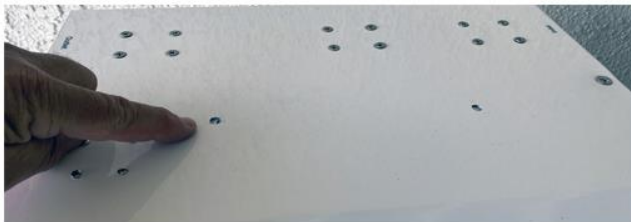

**(2) Pre-Drilled Holes
on top of Unit**



**Install Clips with nuts and bolts
provided**



Snap UV in Place

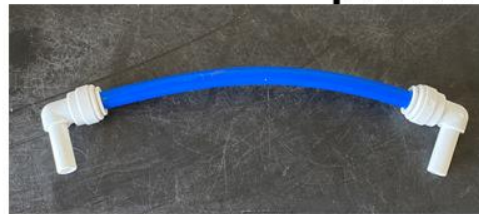

**Connection Tube Connect one side
onto UV**



**Connect the
other side to Outlet**



**Connection Tube
Installed**



**Plug for UV Bulb
located under Bottom
panel**

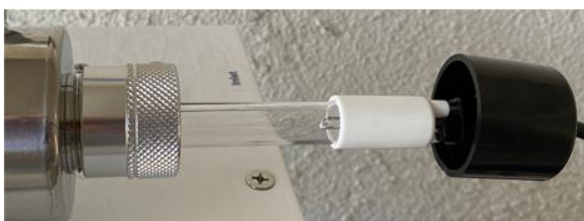

Plug Uv Bulb in



Push in to seal



Craft Brew 850 maintenance schedule

Recommended maintenance schedule for the Craft Brew 850 Reverse Osmosis Brewing System.

Filter change:

Every three months change sediment, pre-carbon and post-carbon filters.

Membrane:

Every 2 to 3 years.

Depending on incoming water conditions, you may need to replace your membrane more often. Keep an eye on your product flow rate, TDS and your system pressure. If flow rates start to drop in system pressure starts to rise, you may need to change your membrane.

Using quality replacement filters and membranes is essential for long term performance. Go to our web site to re-order these maintenance items to maintain the high quality of your system.”

For Filters and Parts

[Click Here](#)

For Start Up Video

[Click Here](#)

If you have any questions, we are always available at 805-777-7037.

Introduction / System Specifications 3

I. Principles of Reverse Osmosis 4

- Reverse Osmosis Process 4
- Semipermeable membrane 4
- Factors affecting membrane service life 4
- Reverse Osmosis System Terms and Definitions 4
- Feed Water requirements 5

II. Identifying System Components 5

III. Pre Installation References 7

IV. Reverse Osmosis System Installation 7

V. Membrane Installation 7

VI. EC-100 controller programming 8

- Controller screen 8
- Navigation and Programming Menu 8
- Controller Programming 8
- Information displayed on screen 9
- Settings Parameter 9
- Cable connection identification 10
- Calibration of TDS sensor 10
- Control box features 10

VII. Start-Up 11

- Initial tests 11

VIII. Troubleshooting Guides 12 - 13

IX. Reverse Osmosis Pre-Treatment 14

Warranty 15



WARNING! READ ENTIRE MANUAL COMPLETELY. FAILURE TO FOLLOW ALL GUIDELINES COULD CAUSE PERSONAL INJURY OR PROPERTY DAMAGE.



REVIEW AND FOLLOW LOCAL LAWS REGARDING PLUMBING INSTALLATION OF THIS EQUIPMENT.



WARNING! DO NOT USE WITH WATER THAT IS MICROBIOLOGICALLY UNSAFE OR OF UNKNOWN QUALITY WITHOUT PROPER DISINFECTION BEFORE OR AFTER THE EQUIPMENT.

NOTE: Failure to comply with these instructions will void equipment warranty and the installer will be responsible for service, damages and repairs.



INTRODUCTION

Water is an important part of all process applications. In order to always provide the highest quality of water to the end consumer, we must make sure to have all the required parameters for each application. Correct information is important in order to safeguard the welfare of consumers when it comes to water quality for food processing, beverages or whatever the final application may be. Proper selection of treatment technology must be evaluated in a case by case basis.

The physical, chemical and microbiological characteristics of water vary from one source to another. Proper water analysis is important in order to know the unique parameters of the water to be treated. Remember that water is a universal solvent and each water supply has different quality characteristics.

It is worth mentioning that in water analysis: dissolved solids (ions or dissolved minerals) whose concentration determine water salinity is measured as TDS (total dissolved solids) or electrical conductivity. Suspended solids and colloids are the ones that give the characteristics of water turbidity. Organic components and micro-biological and other chemical parameters such as pH, dissolved gases, hardness, silica and dissolved metals are equally important to determine the quality of incoming water to any water conditioning process.

Tritton IXC Reverse Osmosis systems have been designed and tested to provide high quality water and have been built with quality components that provide you not just high grade water, but also gives you full confidence in its operation and durability.

SYSTEM SPECIFICATIONS

Craft Brew 850 Reverse Osmosis System

Membrane Housing:	4" x 21" Stainless Steel
Pump:	Brass Vane Type (coupled with 1725 rpm motor)
Operating Pressure	100 - 150 psi
Feed Solenoid Valve:	Brass 120v 3/8 Connection
Flow Meters:	(2) Panel Mount 0.1 - 1 GPM
Pressure Gauges:	100 & 300 Glycerin Filled
Waste and Recirculation Valve:	316 Stainless Steel Needle Valve
Filter Housings:	(3) NSF, 10" 1/2 White
Prefilters:	(1) 2.5" x 10" 5 Micron Filter (1) 2.5" x 10" Carbon Block
Post Filter:	(1) 2.5" x 10" Carbon Block
RO Membrane:	(1) 4" x 21"
System Dimensions:	26" x 23" x 20"
Weight:	75 lbs
Electrical:	120v/60hz
Controller:	Integrated Aquatrol provides automatic operation for optimum performance includes: -Low Pressure Switch -Motor Contactor -Level Switch Manual-automatic selector switch TDS sensor to monitor the water quality product
Polaris UV	2 GPM

** The system production rate is based on minimum feed water quality below 1,000 PPM, feed water temp 77 °F, and SDI < 5. Use a suitable pretreatment capable of removing all membrane damaging substances.*

If you purchased any of these systems with some variation or special design and it is not described in this manual, please contact us indicating the corresponding serial number.

Please read the information contained in this manual before starting operation of the reverse osmosis system. Any misapplication could void the warranty or cause equipment damage.



THIS REVERSE OSMOSIS SYSTEM IS DESIGNED FOR WATER PURIFICATION PURPOSES ONLY.



**THIS REVERSE OSMOSIS SYSTEM MUST BE PROTECTED FROM NATURAL ELEMENTS.
RAIN AND EXPOSURE TO UV RAYS CAN CAUSE PERMANENT DAMAGE TO THE SYSTEM.**



**EXPOSURE TO VERY HIGH HUMIDITY MAY CAUSE DAMAGE TO PUMP MOTER
AND ELECTRONIC CONTROLS.**

I. Principles of Reverse Osmosis Technology

How the Reverse Osmosis process works?

Reverse Osmosis (RO) is a process in which water is forced to pass through a semipermeable membrane by pressure.

As the water passes through the membrane dissolved particles are rejected by the membrane in its spiral layers of semipermeable material formed around a central perforated tube.

Semipermeable membrane

The reverse osmosis system uses the properties of a microporous membrane that works as an efficient particulate filter up to the size of chemical molecules or ions. The rejection of these particles is compared to molecular weight and ionic charge. For example, we can expect a 90% rejection of sodium chloride, which means that the product passing through the membrane will have a concentration of about one tenth of the incoming water. The rejection of calcium carbonate (hardness) will be about 95%, while most of the salts will be rejected approximately 98% to 99%.

Ion rejection or organic material is basically done by mechanical filtration. Most substances with molecular weight of more than 100 will be completely rejected by the membrane. Particles with very low molecular weight such as formaldehyde or free phenol can pass through the membrane (RO), like most dissolved gases.

Disposal of unwanted particles is accomplished by constant flow of water that is circulating, making the function of rinsing the membrane, which prevents saturating surface and reduces the tendency to form scale.

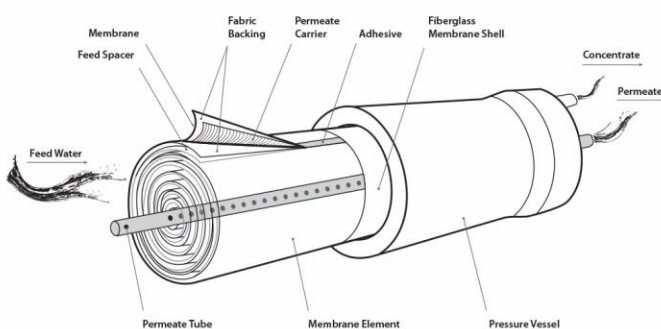

Factors that affect the operation and life of the membrane

There are five main factors affecting the reverse osmosis membrane:

1. Pressure: Excessive pressure may deform and compress the membrane which can cause decrease water production.

2. Hydrolysis: It is a chemical reaction of water that affects the membrane. This happens when the water temperature is very high and the pH is below 2.5 or above 7. To avoid this, keep the pH between 5 and 6.

3. Bacterium: The presence of bacteria deteriorates the surface layer of the membrane and reduce the ability of the membrane to reject salts.

4. Temperature: Avoid temperatures above 95 ° F (35 ° C) to avoid damaging the membrane structure.

5. Saturation: These are salts (calcium carbonate, etc.) that are precipitated on the membrane. These salts clog the pores and channels reducing the amount of water produced.

Temperature in reverse osmosis units:

The units are designed for a temperature of 77 ° F (25 ° C). The production flow is reduced at low temperatures. On average membranes lose at least 1.8% of production for each degree below 77 ° F.

Some common terms and definitions related to reverse osmosis

Incoming (feed) water - Pre-filtered and softened water introduced to the reverse osmosis modules.

Product Water - Purified water produced by reverse osmosis membranes.

Water Concentrate (rejection) - High waste containing water (reject) that goes directly to the drain.

Membrane - Internal semipermeable element core of your reverse osmosis system.

Module - is the complete membrane inside a pressure vessel

GPD (Gallons per day) - Unit of measure which determines the water production of the membranes. Example: A system 1,000 GPD reverse osmosis will produce 1,000 gallons of pure water in a 24 hour period (maximum working 24 hours / day).

PPM (Parts per million) - Method used to measure the quality of water in the reverse osmosis.

Percentage Recovery - The amount of water recovered through the membranes. Example: If you enter 100 gallons of water into the membrane, and produce 60 gallons of clean water to 40 gallons of reject water, this means the RO System has a 60% recovery.

Percentage Rejection - The amount of salts and chemicals rejected or removed by reverse osmosis membranes.



Feed Water Requirements

TYPICAL EXPECTED ION RETENTION IN A TFC MEMBRANE TYPE:

TYPICAL EXPECTED ION RETENTION IN A TFC MEMBRANE TYPE	
SODIUM	85-94 %
LEAD	95-98 %
SULFATE	96-98 %
ARSENIC	92-96 %
CALCIUM	94-98 %
MAGNESIUM	94-98 %
POTASSIUM	85-95 %
NICKEL	96-98 %
NITRATE	60-75 %
FLUORIDE	85-92 %
IRON	94-98 %
MANGANESE	94-98 %
ZINC	95-98 %
CADMIUM	95-98 %
MERCURY	95-98 %
BARIUM	95-98 %
SELENIUM	94-96 %
CYANIDE	84-92 %
PHOSPHATE	96-98 %
CHLORIDE	85-92 %

WATER SUPPLY REQUIREMENTS:

TYPICAL RETENTION OF A REVERSE OSMOSIS MEMBRANE	
TEMPERATURE	8-27 C
HARDNESS	< 20 PPM
RESIDUAL CHLORINE	0 PPM
TDS	< 1000 PPM
pH	3 A 11
IRON	< 0.01
SILICA	< 10 PPM
MANGANESE	< 0.05 PPM
INLET PRESSURE	30-60 PSI

II.- SYSTEM COMPONENTS

- 1. PREFILTER PRESSURE GAUGE:** Glycerin filled pressure gauge (0-100psi). Standard on all units and is located on the front of the panel. This gauge measures the water pressure in PSI at the outlet of the pre-filter, a minimum pressure of 30 PSI is recommended
- 2. SYSTEM PRESSURE GAUGE:** Glycerin filled pressure gauge (0-300psi). Standard in all units. Located in front of the panel and senses the pump pressure discharge. This gauge measures the pressure of water in PSI which is applied through the membrane. (Maximum recommended operating pressure is 180-200 PSI, depending on the type of membrane).

The operating pressure of the system can be adjusted by regulating these combined valves:

- Turning waste valve handle to the right the pressure increases; turning the valve handle to the left pressure will decrease.

⚠ CAUTION! Do not close this valve completely.

- By adjusting the recirculation valve located next to the waste valve above. Turn right to increase pressure and close recirculation flow or turn the handle to the left to decrease pressure and open recirculation flow.

- 3. CONCENTRATE WATER FLOWMETER (WASTE):** Located on the front of the panel, this meter is calibrated in gallons per minute. Its purpose is to measure the amount of waste water that the system is producing.
- 4. PRODUCT WATER FLOWMETER (PERMEATE):** located on the front panel, its purpose is to measure the amount of product water in gallons per minute.
- 5. RECIRCULATION FLOW METER:** Located on the front panel, its purpose is measure the amount of waste water that it returns to feed the system and is blend with raw water.
- 6. REVERSE OSMOSIS MODULE:** It consists of a membrane housing and the membrane. The assembly is placed vertical on TRITTON IXC models.
- 7. WASTE VALVE:** This valve is located on the front panel. Its purpose is to restrict the flow of water concentrate leaving the module, it creates the necessary pressure inside the module so that water is forced into the membrane creating the reverse osmosis effect.



Turning the valve knob will control the ratio of water discharged / water produced.

- Turning clockwise will increase pressure inside of the module and reduce the amount of waste water.

- turning counterclockwise pressure will decrease within the module and increase the amount of waste water.

⚠ CAUTION! Keep in mind the recovery (product / rejection) suggested by your dealer based on water analysis done.

⚠ CAUTION! Waste valve should never be completely shut.

⚠ WARNING! Do not exceed the recommended pressure of membrane parameters.

8. RECIRCULATION VALVE: This valve is located on the upper front panel. Its purpose is to adjust the amount of waste water that recirculates into the feed water of the system. It is used to refine and adjust pump pressure. You should be careful of the characteristics of the incoming water, not to exceed the rate of salinization with imbedded tendency such as calcium, magnesium, silica and avoid membrane fouling problems.

9. THROTTLING VALVE: located on the output of the high-pressure pump, it is used to adjust supply pressure and flow. Depending on the type of membrane used it adjusts flow and pressure.

10. PRE-FILTER: This filter is a 5-micron pre-filter. It is used to remove any particles that may have passed through pre-treatment or released by pretreatment materials. If the cartridge is dirty it can cause loss of pressure. See Reverse Osmosis Pretreatment section on page 11 to find out the kind of filter that is recommended.

⚠ NOTICE: Never use this filter as the only way of Pretreatment for your reverse osmosis system.

11. HIGH PRESSURE PUMP: This creates high pressure for proper reverse osmosis operation. This pressure is adjusted by the waste valve and the recirculation valve.

⚠ CAUTION! Never use the pump without water.

12. CONTROL BOX: The Reverse Osmosis system is designed to be automatically operated by an electronic control. The EC-100 control monitors the operation parameters of the system and sends continuous information to the screen.

In addition, the system has security features integrated into its design to protect components and continuously monitor the quality of product water produced.

Pump Motor overload - Amperage surges are addressed by a thermal relay located on the starter installed for the high-pressure pump.

Start Timer delay - The start delay or pump start delay is 10 seconds. This helps detect potential problems with the solenoid valve or voltage spikes.

Low Pressure Switch - Protects the high-pressure pump to not operate without water, detects no or low pressure in the system and immediately shuts down the system and sends a notice to the screen. Low pressure switch is activated at 10 PSI.

Tank Level Switch - Installed in the product water storage tank. It controls the level and sends a stop signal to the system when tank is full to prevent overflow.

Product Water Quality Sensor - The system has an integrated TDS sensor for monitoring water quality and is constantly visible on the control screen. The TDS sensor can be read in PPM and can be set to trigger an alarm if water quality is abnormal.

Fast Flush - The system can be enabled (*optional*) for an automatic flush to be performed every 2 hrs. (*time can be varied in programming*). If programmed a solenoid opens, the system is depressurized for the selected amount of time and waste water is purged to help protect the system from fouling membranes.

13. INLET SOLENOID VALVE: Normally closed solenoid valve (NC). This valve is located on the feed side of the pressure pump. Its purpose is to stop the water supply when the unit is not operating. If the power fails, this valve will close.



III. PRE INSTALLATION REFERENCES

Inlet Feed Water - enters through the pre-filter housing. The housing connection is ¾" or 1" depending on the model. We suggest system connections are made preferably with PVC SCH 80 or SCH 40.

Outlet Product Water - On IXC systems, the permeate water output exits through the product water flow meter. through the back of the system.

Outlet Waste Water - On IXC models, waste water or concentrate exits the reject water flowmeter through the back of the system.

Control Box Power and Voltage Connections - The IXC-1SS, IXC-2SS and IXC-3SS are supplied with standard 120 volt, single phase connections. In situations where the customer specifies otherwise, there may be changes in this regard. All systems must be installed in accordance with local regulations.

All IXC Commercial RO Systems use a 120V, single-phase voltage in the control box and can be converted to 220V. IXC-4SS models come in 220V and cannot be converted to 120V.

Switch and Product Water Level Connections in the Storage Tank - The cable connections of the liquid level switch are located directly on the top side of the electrical control box. The two wires are connected together with the level switch cables. When the switch is closed, the reverse osmosis system is switched on. When the switch is open the reverse osmosis system is switched off.

⚠ It is extremely important to make sure you know all regulations pertaining to local, building, electrical and plumbing parameters of the site where you are installing the system.

IV. REVERSE OSMOSIS SYSTEM INSTALLATION

INSTALL FOLLOWING THESE STEPS:

1. Choose a place that is covered and has enough space for the system. The location should also have feed water, electricity and a specified area for drainage. It is not recommended to install the system in an area exposed to the elements.

- Start by connecting all water connections to the system and its pre-treatment.

2. Install the filter inside the housing or make sure it's inside the housing.

Recommendations how to insert membranes into the SS housing:

- To insert the membrane in the SS housing it is recommended to remove the cap from the housing, instead of disconnecting all the quick connections and tubing.

- When installing the RO membrane, make sure to look at which direction the arrow is pointing (indicates feed water flow); and where the brine seal will be located.

- When the arrow is pointing up it is recommended to remove both housing caps.

- Then remove the brine seal from the membrane and insert the membrane thru the top of the SS housing (without brine seal).

- Once the membrane reaches the bottom of the housing, re-insert brine seal on to the membrane. And then, when the brine seal is in the correct orientation, slide the membrane up into the housing. Re-install lower and top caps and clamps.

- When installing the membrane with the arrow pointing down, just remove top cap and clamps.

- Slide membrane down until it seats in the lower cap, in this case no need to remove brine seal. Re-install top cap and clamp.

3. Install the membrane(s) in the membrane housing(s). The membrane housings have an arrow indicating the direction of flow. The seal of the membrane should always be installed in the same direction of the water inlet.

(See diagram below, chapter V of this manual).

4. Open the recycling and rejection valves completely.

5. Make all electrical installations including the storage water tank level switch. Make sure the system is connected to an independent designated main breaker.

V. MEMBRANE INSTALLATION

⚠ Membrane seal should always be Installed in the same direction as the flow of incoming water.

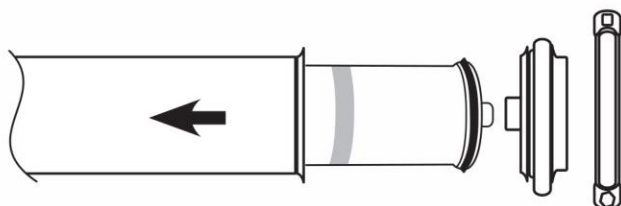

**Note the direction of the membrane seal in the following diagram.*

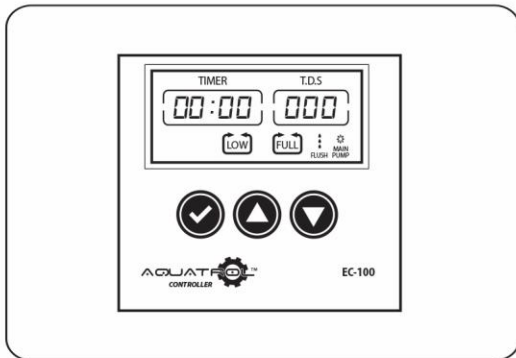

VI. PROGRAMMING THE EC-100 CONTROLLER

NAVIGATION AND PROGRAMMING MENU:



-  SET key, is access to settings mode
-  UP key increases the setting values
-  DOWN key decreases the setting values

Main screen: Displays the operating status:

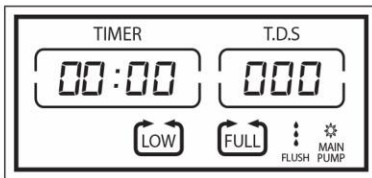

FLUSH (Activated) - Purges at low pressure (*Valid on systems with Fast Flush option*)

LOW - Indicates that the system is protected by low pressure and is off (standby) until there is sufficient inlet pressure to restore system operation.

FULL - Indicates that the system is in standby as the stop signal was received by high product water level in the storage tank.

TIMER - The time the system has been in continuous operation.

⚠ IXC SYSTEMS DO NOT KEEP CONTINUOUS TIME IF POWER IS LOST OR IF A LOW PRESSURE OR WATER LEVEL ALERT IS INDICATED AND THE SYSTEM IS SHUT-OFF.

- At initial start-up, the IXC system counts in seconds until it reaches minutes and later to hours as in the example below.



- When the system reaches 1 hour of continuous operation the system screen counts in hours and minutes as in the example below.



⚠ IF POWER IS INTERRUPTED OR IF THE SYSTEM IS SHUT-OFF BY A WARNING SWITCH. THE SYSTEM WILL START FROM ZERO AGAIN.

TDS - Registers the quality of the product water by measuring the total dissolved solids in PPM units.

By default the controller provides a 10 second delay in start-up of the system when you place the selector switch on **AUTO** for double electrical protection of the system.

CONTROLLER PROGRAMMING:

The IXC Reverse Osmosis System has already been factory programmed with pre-set parameters for basic operation, however if you want to adjust time setting for models purchased with fast integrated flush, then follow these instructions for adjustment:

1. With the system plugged and selector switch off is in **AUTO**, press and hold down the SET key for 3 seconds to enter the settings mode until you hear a "Beep" and enter the options menu to adjust the setting parameters. P1 starts with the UP and DOWN keys to adjust the parameter as you need. Once complete press the SET key again to pass to the next parameter (P2) and so on until you make your adjustments up to P6 and then go back to the home screen.
2. If you purchased a system with membrane fast flush option, you can run the fast flush manually by pressing for 5 seconds the UP and DOWN keys simultaneously and this will be activated for the time you have previously programmed it.
3. Or you can stop the fast flush process and adjust less time while in manual mode by pressing the DOWN button to stop flushing and adjusting less or more time. Hold the DOWN key when you want to return to the original count.



INFORMATION DISPLAYED ON SCREEN:



Timer - Indicates the time the system has been working and starts measuring a range of time (*minutes: seconds*), after an hour of operation this changes its time reference to: (*hour: minute*).

You can also view here when the membrane is in fast flush mode. It will display a countdown in seconds.

When the system is on (*stand by*) but has the power On- the control will save information showing how long the System has been operating. If for any reason the system does not get an electrical supply the information stored previously will be lost. After 9999 hours, the timer will return to 000 hours.



TDS - Shows the quality of product water in TDS PPM being obtained at that time.



LOW : When this appears on the screen, it indicates low pressure in the system. Additionally, on the control box, a Yellow light will illuminate when there is low pressure as a visual reference.



FLUSH - When membrane flush is activated, droplets above the word FLUSH are displayed.



MAIN PUMP - This display represents the high-pressure pump of the System is activated. When Blades are in motion it means the pump is ON. In addition, the green light on the control box will indicate that the system is in operation.



FULL - Appears on the screen when a signal is received that the storage tank is full.

SETTING PARAMETERS:

P1 - Time Setting adjustment for the duration of the membrane fast flush; 15 sec, 30 sec, 45 sec, 60 sec.

P2 - Setting for adjusting the start-up delay time for the start if the system receives any signal by the low pressure or high level switch; 0 sec = off, 5 sec, 10 sec, 15 sec, 20 sec.

P3 - (*OPTIONAL FEATURE – SKIP IF FAST FLUSH WAS NOT PURCHASED WITH THIS FEATURE*) Select frequency or time between each membrane fast flush when the system is operating; 0 = OFF (*OFF function*), 1 hr, 2 hr, 3 hr, 4 hr, 5 hr, 6 hr 7 hr, 8 hr, 9 hr, 10 hr 11 hr 12 hr. (*only used when purchasing a system with fast flush integrated*)

P4 - (*OPTIONAL FEATURE – REQUIRES PROGRAMMING*) Select frequency or time between each membrane flush when the system is in standby; 0 = OFF (*OFF function*), 12 hr, 24 hr, 36 hr, 48 hr, 60 hr, 72 hr, 84 hr, 96 hr.

P5 - TDS range selection (*set point*) if you want to send an alarm signal indicating that water quality has changed; 0 = OFF (*function off*), it can be adjusted 10 PPM to 200 PPM. The control will trigger an alarm indicating that the quality of water changed, then the alarm will repeat every hour, until you identify and correct the problem with the TDS.

P6 - Parameter based on the sensitivity setting of the TDS meter. The lower this parameter the best sensitivity will be for this sensor. It is suggested to be set to less than 15 PPM after calibration.

The last screen in the parameter settings records the last 5 events of "non operation" presented by the system and how long it was off. Up and Down Arrow reads T1, T2, T3, T4 and T5 are records in the memory of the "non operation" and indicates which switch was deactivated.

Parameter settings recommended for basic automation:

P1 = 15 P2 = 0 P3 = 0
P4 = 0 P5 = 50 P6 = 15



CABLE CONNECTION IDENTIFICATION:

- Violet:** Low level Switch in the raw water tank (SW1) (*)
- Blue:** Shut-Off Switch for the pre-treatment (SW2) (*)
- Green:** Storage tank level switch (FULL)
- Yellow:** Low pressure switch (LOW)
- Gray:** Booster Pump System (FEED)(*)
- Orange:** Solenoid Valve for membrane flush (FLUSH)
- Brown:** High Pressure Pump System
- Red:** Solenoid Valve water feed system
- Black:** Power 110 V-240 V

(*) Deactivated in IXC models

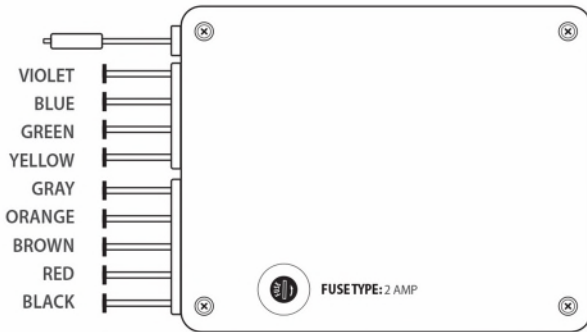

**TDS SENSOR CALIBRATION
(CONTROLLER):**

- The controller has a basic TDS sensor that gives you a reading of the quality of your product water that fills your tank.
- If you want to verify the calibration of the sensor, we recommend solutions of 5 PPM or 10 PPM maximum.
- Turn the selector switch off, remove the sensor from its original position, introduce it into the reference solution and check the reading on the screen. The switch is off, but the controller must be on.
- If there is a difference between what we read on the screen, then press the SET button for 3 seconds and go to parameter P6 and select the value of the reference solution with the UP or DOWN keys and then press SET.
- Reconnect the sensor in its original connection..

**FEATURES OF CONTROL BOX USED
BREWING 1000 SYSTEM:**

- Nema 4 Box: ABS
- Electrical Contactor: 24 AMP
- Thermal Relay: 24 AMP
- Low Pressure Switch range: 4-12 PSI
- Selector Switch 2 positions (OFF - AUTO)
- Low pressure indicator light: Yellow LED Type
- Power indicator light: Green LED Type
- Level switch is provided for field installation (in separate bag)
- Power supply options: 120 V (220 V + Neutral on 4SS model)



VII. START-UP

1. Make sure that everything related to the pre-treatment process is operating properly and has been backwashed several times to avoid fines from entering the system.
2. Turn the switch on the control box to AUTO. The indicator light on the display lights and the low pressure indicator is activated.
3. All pressure gauges will read 0.
4. Activate the feedwater by opening the supply valve to the system.
5. Make sure the waste and recirculation valve are fully open.
6. The inlet pressure gauge should climb to 30 PSI. When the inlet pressure reaches approximately 20 PSI the low pressure indicator light will turn off.

Note: Ensure all air is purged from system using red pressure relief button on the top of system.

7. After 10 seconds the pump will come on. After the pump turns on the system pressure gauge will begin to rise.
8. Purge for 10 minutes before adjusting the waste valve by closing it slowly until the product and waste indicator show the same values in GPM.

⚠ NEVER allow the gauge pressure to exceed 200 PSI.

9. Adjust the waste valve by slowly closing it until the system pressure is in the range of 140-200 PSI depending on the type of membrane used.

⚠ NEVER completely close the waste valve.

10. The reverse osmosis unit is now in operation. Check for leaks. PPM product water will take approximately 60 minutes to reach the optimum final quality since the membranes must be flushed from preservatives.

⚠ WARNING: The reverse osmosis system must be flushed thoroughly for one hour before using the product water. The concentrate and permeate should run to a suitable drain for flushing the system.

INITIAL TESTS

After 15-30 minutes both the feedwater and the product water must be monitored with the TDS meter. You must obtain at least 90% rejection in the final product water quality.

If the rejection is less than 90% recheck the installation of the membrane and that they are positioned in the right direction by making sure the seals of the membrane are in the same direction of the flow of water. Also check o-rings and membrane caps to identify where the problem is.

Disconnect the cables from the level switch and make sure that:

1. The system pump turns off automatically.
2. There should be pressure on your pre-filter and remain stable.
3. The pump system is switched off and both the flow to product and waste stop (no output).
4. The control box must remain on and the screen illuminated when the level switch is open, the screen will show full.

Reconnect the wires to the liquid level switch. The pump will automatically turn on. The pressure will increase and the water will flow through the product and rejection.



-VIII. TROUBLESHOOTING GUIDE

SYMPTOM	POSSIBLE CAUSE	SOLUTION
THE REVERSE OSMOSIS SYSTEM WILL NOT START.	Power switch is off.	Place in AUTO position.
	No power.	Check power outlet and make sure system is plugged in.
		Check 2AMP fuse on back of controller.
	Not enough inlet pressure and the low pressure switch is not activated.	Verify that the feed valve is fully open.
		Make sure your pre-treatment pump is operating properly to supply pressure to the reverse osmosis system.
		Check continuity in the low-pressure switch to ensure it is in good condition and / repair or replace.
		Check that pretreatment does not exceed the pressure drop as this low feed can lead to insufficient water pressure to system.
	Timer start is failing in the electronic controller.	Check programming boot time.
Magnetic starter is burned.	Check if overload relay is not under protection. Push black square button at the right of relay to reset. Note: Green LED will be off.	
The level Switch is open.	Check to see if the storage tank is filled with product water. Lower the level for the switch to close and send the start signal to the system.	
Pump motor burned.	Check with a multimeter all electrical connections and switches to determine cause of failure before replacing the motor.	
NO HIGH PRESSURE IN THE SYSTEM.	Air in the system.	It is normal for the system to have and purge air. Let the system run for a while (at least 5 minutes) before starting to adjust the pressure.
	Waste Valve open.	Adjust the recommended pressure to the membrane type selected.
	Recirculation valve completely open.	Check and Adjust.
	Faulty pressure gauge.	Check and Replace.
	Tubing or hose kinked or blocked.	Check, replace the tubing.
	Pump impellers are worn or damaged.	Check impellers and replace if necessary.
	There is not sufficient water pressure feeding the system and the pump is also sucking and pressurizing at the same time.	DANGER! This can collapse pressure tanks on pre-treatment. Check system feed pump as well as its pre-treatment and correct.
	Wrong voltage feed.	Make sure the power supply is the voltage that corresponds to your system and make adjustments if necessary.
Measure motor amperage and verify that it is within the range of motor nameplate for supply voltage. Make adjustments necessary.		
Clogged or faulty solenoid.	Check if your solenoid valve is operating properly And does not have something stuck internally, Check and correct.	
NO WATER OR TOO LITTLE REJECTION.	Membrane Fouled Open	Check the TDS on the product line, if the TDS is the same as the feed water line, the membrane is fouled open or there is a leak of reject water through an oring. Check and if necessary change orings on membrane housing caps or replace the membrane.
	Waste valve clogged	The pressure exceeds the initial set limit indicating that salts saturation was excessive and is obstructing the waste valve or drain line. Verify that the drain tubing is not bent or kinked, confirm the cause and correct.



SYMPTOM	POSSIBLE CAUSE	SOLUTION
NO PRODUCT OR TOO LITTLE WATER PRODUCTION.	saturated or dirty membrane.	Check, clean, replace if necessary.
	The water temperature is very low.	Check your feed water temperature, check your correction factor for the temperature and make sure that the flow is at an acceptable level.
	Low pressure in the system.	Check other causes mentioned in this manual under issues of not having enough pressure.
PRODUCT WATER WITH HIGH CONTENT OF DISSOLVED SALTS (TDS).	Low pressure in the system.	Waste valve open, check and adjust. Check other causes mentioned in this manual under issues of not having enough pressure.
	Osmosis membrane seal is not seated or in good condition inside the membrane housing.	Check that the membrane is installed properly and for leaks in the oring or cap causing a mixture of water and waste-product.
	Reverse osmosis membrane exhausted.	The membrane life is on average 2 years. Replace the membrane if life already exhausted.
	Product lines and waste water are reversed.	Change and correct reversed connections.
	The amount of TDS in the feedwater changed.	An increase in its raw water TDS can alter product water quality, verify the cause of this increase and that the membrane is rejecting the percentage of suitable salts.
DIFFERENT TASTE AND ODOR IN WATER PRODUCT.	Saturated and polluted membrane (bacteria).	Check, perform chemical cleaning, replace if necessary.
	Presence of foreign matter in the tank storage.	Clean, empty and sanitize the tank.
		Replace filter cartridges.
	Product lines and waste water are reversed.	Change and correct reversed connections.
	Presence of foreign matter in the tank storage.	Integrate special pre-treatment to remove gases.
	Problems with your pre-treatment.	Exhausted filter media.
		Softener without sufficient rinse time and sends saltwater into the reverse osmosis system. Correct the problem.
	Reverse osmosis membrane exhausted.	The membrane life is on average 2 years. Replace the membrane if life has been exhausted.
Osmosis membrane sealing is not perfect in the membrane housing.	Check that the membrane is installed properly and for leaks in the oring or cap causing a mixture of water and waste-product.	
Post-carbon filter is exhausted.	Replace the Post-carbon filter block if one is installed.	

Connections



Bulkhead for
Product Water Storage Tank

Water

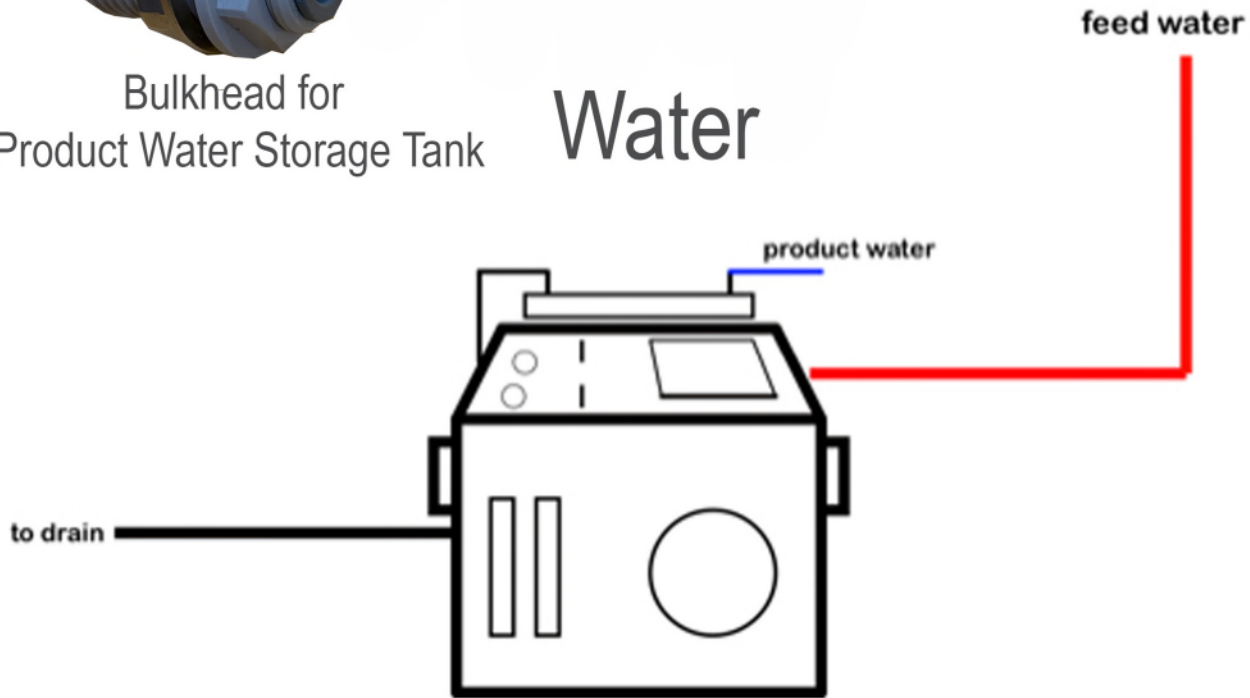

Float Switch



Float Switch Connection is located on right side of system
under the panel attached to control box

The products described in this document are hereby offered for sale to be established by Hydrofit Quick Connect Fittings, Polaris Scientific Ultraviolet, Hydron Membranes, Aquatrol, Shok Blok, HydroGuard, Hydronix Water Technology, any of its subsidiaries and its authorized distributors. This offer and its acceptance by any customer (the "Buyer") shall be governed by all of the following Terms and Conditions. Buyer's order for any item described in this document, when communicated to Hydrofit Quick Connect Fittings, Polaris Scientific Ultraviolet, Hydron Membranes, Aquatrol, Shok Blok, HydroGuard, Hydronix Water Technology, its subsidiaries or an authorized distributor (the "Seller") verbally or in writing, shall constitute acceptance of this offer. Provided, however, that these terms and conditions shall not operate as a rejection of the Buyer's offer unless such offer contains variances in the description, quantity, price, or delivery schedule of the items.

1. Terms and Conditions of Sale.

All descriptions, quotations, proposals, offers, acknowledgments, acceptances and sales of the Seller's products are subject to and shall be governed exclusively by the terms and conditions stated herein (the "Agreement"). The Buyer's acceptance of any offer to sell is limited to the terms and conditions in the Agreement. Any terms or conditions in addition to or inconsistent with those stated in the Agreement, proposed by the Buyer in any acceptance of an offer by the Seller, are hereby rejected. No such additional, different or inconsistent terms and conditions shall become part of the agreement between the Buyer and the Seller unless expressly accepted in writing by the Seller. The Seller's acceptance of any offer to purchase by the Buyer is expressly conditioned upon the Buyer's assent to all the terms and conditions in this Agreement, irrespective of any terms in addition to, or inconsistent with those contained in the Buyer's offer. Acceptance of the Seller's products shall in all events constitute such assent.

2. Documents.

Unless provided otherwise in the Agreement, all catalog descriptions, illustrations, drawings and literature or independently submitted estimates of performance, weights and measurements or other specifications provided by the Seller are mere approximations and the Seller reserves the right to alter or amend them at any time. The Seller reserves the right to correct clerical or technical errors in the contract documents. The Buyer shall furnish with his order all necessary specifications and information. The Seller takes no responsibility for goods manufactured, priced or delivered not in accordance with the order or the specifications unless the Buyer's order and specifications are clear and correct.

3. Prices.

Unless otherwise provided, all prices contained in our quotations and written acceptances are ex-works and do not include the cost of packing. All orders are accepted on the condition that all such prices are subject to revision by the Seller at any time before the goods are dispatched to take account of any price change. In the event that the Buyer does not place the entire order quoted by the Seller for the Buyer, the Seller reserves the right to revise its prices. The Seller also reserves the right to revise its prices if the Buyer modifies the specification or quantity of the goods or the delivery requirements after the order has been accepted by the Seller.

4. Advice.

All advice given in connection with the Seller's goods is provided without charge to the Buyer. ANY ADVICE AND ASSISTANCE GIVEN BY THE SELLER TO THE BUYER IS GIVEN AT THE BUYER'S RISK, AND THE SELLER SHALL NOT BE LIABLE FOR ANY LOSS, DAMAGE OR CLAIM ARISING THEREFROM.

5. Payment.

(a) Unless otherwise provided in the Agreement, or explicitly agreed upon in writing by the Seller, payment is due in full 30 days from date of shipment of the items purchased herein under. (b) In the case of an installment contract, deliveries or parts, payment for each installment delivery or part shall be made under sub-clause (a) as if the same constituted a separate agreement. (c) Amounts not timely paid shall bear interest at the rate of 2-1/2% above the Seller's bank's prime rate from time to time in force. (d) In the event that the Buyer fails within one calendar month of the date for payment to effect any payment which may be due under the Agreement or any agreement with the Seller, or if the Buyer commits any breach of the Agreement, or if the Buyer becomes insolvent or commits any act of bankruptcy or contemplation of liquidation, the Seller will be entitled, without prejudice to the Seller's other rights, to terminate the Agreement or any unfulfilled part thereof, or at the Seller's option to make partial deliveries.

6. Modifications and Cancellations.

This Agreement is not subject to oral modification or cancellation. A Buyer's request for modification or cancellation will not be incorporated into the Agreement unless the request is accepted by the Seller in a writing that amends the Agreement. Acceptance of any such requested modification or cancellation shall be at the Seller's discretion and shall be upon such terms and conditions as the Seller may require.

7. Handling Charge.

Goods supplied in accordance with the Buyer's order may later be returned to the Seller at the Seller's discretion provided the return is pre-authorized in writing and the merchandise is unused, in original packages, unaltered, clean and no older than 60 days from the date of shipment by the Seller. The Buyer will be required to pay to the Seller a handling charge of 25% of the purchase price of the returned goods. A copy of the original invoice for the merchandise must accompany all returns.

8. Delivery.

(a) Any delivery dates quoted are approximate only and the Seller shall have no liability for any delays in delivery. (b) Unless provided otherwise, delivery of the goods shall be made when the Seller has notified the Buyer that the goods are ready for dispatch. Regardless of the method of delivery, delivery shall be made F.O.B. Seller's plant, where the risk of loss shall thereupon pass to the Buyer upon the Seller's delivery to a carrier. Notwithstanding that the Seller's prices are ex-works, the Seller is prepared by special contract to procure carriage and freight and insurance on behalf of the Buyer and at Buyer's cost in which event the Seller shall be under no liability for damage in transit or loss or damage to the goods beyond the point at which the Seller contracts to deliver the same. (c) The Seller will not make drop shipments.

9. Inspection and Rejection.

(a) The following provisions shall apply in relation to all deliveries of goods: the Seller shall not be held liable for any claims of damage in transit, shortage of delivery or loss of goods, unless in the case of shortage of delivery, a separate notice in writing is given to the carrier concerned and to the Seller within three (3) days of the receipt of the goods, followed by a complete claim in writing within five (5) days of receipt of the goods and in the case of loss of goods, a separate notice in writing is given to the carrier concerned and to the Seller and a complete claim in writing made within thirty (30) days of the date of consignment. The Buyer must inspect the goods on arrival from the carrier; however, where goods are accepted from the carrier concerned without being inspected, the delivery book of the carrier concerned must be signed "not examined". The Seller shall have the right to inspect the goods at the Buyer's premises in respect to any such claims made by the Buyer and the Buyer shall retain such goods until the Seller has inspected such goods or until the Seller has notified the Buyer that the Seller does not wish to inspect such goods. Any breach of these conditions in this provision shall serve as a waiver to any claim brought by the buyer. (b) Without prejudice to the Seller's other rights, should the Buyer fail for any reason to send the Seller forwarding instructions within ninety (90) days after the date of the Seller's notification that the goods are ready for dispatch or to accept delivery of the goods, the Seller shall be entitled at the Buyer's risk and expense to store the goods and/or to procure or effect storage of the goods elsewhere. Goods so stored shall be paid for as if they had been dispatched and/or accepted.

10. Special Tooling.

Where it is necessary for the Seller to manufacture or to purchase special tooling, including without limitation tools, dies, jigs, mandrills, fixtures, molds, and patterns, in order to execute a contract, the Buyer will be charged with all or a proportion of the cost of such special tools. Such special tooling shall be and remain the Seller's property notwithstanding payment of any charges made by the Buyer. In no event will the Buyer acquire any interest in apparatus belonging to the Seller which is utilized in the manufacture of the items sold hereunder, even if such apparatus has been specially converted or adapted for such manufacture and notwithstanding any charges paid by the Buyer therefore. Unless otherwise agreed, the Seller shall have the right to alter, discard or otherwise dispose of any special tooling or other property in its sole discretion at any time.

11. Test and Performance.

(a) The Seller's goods are, where practicable, submitted to the Seller's standard test before delivery. If special tests are required, these shall be made at the Seller's premises unless otherwise agreed, and will be subject to an extra charge. (b) The Seller accepts no liability for failure to attain any performance figures quoted by the Seller unless the Seller specifically has guaranteed them with an agreed sum as liquidation damages and the Buyer has suffered actual loss by reason of the failure to attain the figures quoted. (c) Any particulars of weights and measurements, power and consumption, power output or performance relating to the goods and like matters furnished by the Seller to the Buyer in the Seller's catalogs, literature or otherwise, are approximate and are intended only to present a general idea of the goods to be supplied and unless previously agreed specifically in writing shall not form part of the Agreement.

12. Buyer's Property.

Any designs, tools, patterns, materials, drawings, confidential information or equipment furnished to the Seller by the Buyer, or any other items which become the Buyer's property, may be considered obsolete and may be destroyed by the Seller after two (2) consecutive years have elapsed without the Buyer placing an order for the items which are manufactured using such property. The Seller shall not be responsible for any loss or damage to such property while it is in the Seller's possession or control.

13. Taxes.

Unless otherwise indicated, all prices and charges are exclusive of excise, sales, use, property, occupational or like taxes which may be imposed by any taxing authority upon the manufacture, sale or delivery of the items sold hereunder. If any such taxes must be paid by the Seller, or if the Seller is liable for the collection of such tax, the amount thereof shall be in addition to the amounts for the items sold. The Buyer agrees to pay all such taxes or to reimburse the Seller therefore upon receipt of its invoice. If the Buyer claims exemption from any sales, use or other tax imposed

by any taxing authority, the Buyer shall promptly indemnify and hold the Seller harmless from and against any such tax, as well as any interest or penalties thereon which may be assessed if the items are held to be taxable.

14. Warranty.

EXCEPT AS EXPRESSLY WARRANTED IN WRITING BY THE SELLER, THE GOODS SOLD BY THE SELLER ARE PURCHASED BY THE BUYER "AS IS." THE SELLER DOES NOT WARRANT THAT THE GOODS ARE OF MERCHANTABILITY QUALITY OR THAT THEY CAN BE USED FOR ANY PARTICULAR PURPOSE. EXCEPT AS EXPRESSLY WARRANTED IN WRITING BY THE SELLER, THE SELLER MAKES NO REPRESENTATION OR WARRANTY OF ANY KIND WITH RESPECT TO THE PRODUCTS.

(a) The Seller warrants that the items sold hereunder shall be free from defects in material or workmanship at the time of shipment by the Seller. The Seller warrants that if within 12 months of delivery of the goods to the Buyer the Buyer returns immediately to the Seller's premises any of the said goods which the Buyer believes to be defective, carrier paid, properly packed and clearly marked with the Buyer's full name and address and any other information such as serial numbers which may be necessary to enable the goods to be identified, together with a complete description of the alleged defect, they will be repaired or new goods will be supplied in exchange and the goods so repaired or such new goods will be delivered to the Buyer free of charge at the Seller's premises; provided, however, that the foregoing warranty shall be applicable only if upon demand by the Seller, the Buyer proves to the Seller's satisfaction: (i) that the defect was due solely to defective workmanship; (ii) that no alterations or repairs have been made to the goods except with the Seller's written consent; (iii) that the defect was not caused by any act of the Buyer or its agents; and (iv) that the defect was not caused by any matter beyond the reasonable control of the Seller, including, without limitation, accident or normal wear and tear. (b) THIS WARRANTY DOES NOT APPLY UNLESS THE SELLER'S PRODUCTS ARE: (I) USED IN DOMESTIC PLUMBING APPLICATIONS; (II) INSTALLED BY A LICENSED CONTRACTOR, PLUMBER OR QUALIFIED EQUIPMENT INSTALLATION PROFESSIONAL; AND (III) INSTALLED AND OPERATED IN ACCORDANCE WITH PUBLISHED HYDROFIT / HYDRONIX WATER TECHNOLOGY SPECIFICATIONS. (c) All costs and expenses, including freight charges, customs duties, and insurance incurred in returning the goods to the Seller's premises in accordance with this provision shall be paid by the Buyer. The benefit of this warranty shall not be assignable by the Buyer. (d) THIS WARRANTY DOES NOT EXTEND TO ANY GOODS NOT MANUFACTURED BY THE SELLER EVEN THOUGH SUPPLIED BY THE SELLER NOR DOES IT EXTEND TO ANY SECOND-HAND OR RECONDITIONED GOODS NOR DOES IT EXTEND TO COMPONENTS MANUFACTURED BY THE SELLER BUT INSTALLED, ATTACHED OR WELDED BY THE BUYER OR HIS CUSTOMER ON EQUIPMENT NOT MANUFACTURED BY THE SELLER. GOODS NOT MANUFACTURED BY THE SELLER CARRY ONLY THE WARRANTY (IF ANY) OF THEIR MAKERS AND THE BUYER IS ENTITLED TO THE BENEFIT THEREOF ONLY SO FAR AS THE SELLER HAS THE POWER TO TRANSFER IT. (E) THIS WARRANTY COMPRISES THE SOLE AND ENTIRE WARRANTY PERTAINING TO ITEMS PROVIDED HEREUNDER. THE SELLER MAKES NO OTHER WARRANTY, GUARANTEE, OR REPRESENTATION OF ANY KIND WHATSOEVER. ALL OTHER WARRANTIES, INCLUDING BUT NOT LIMITED TO MERCHANTABILITY AND FITNESS FOR PURPOSE, WHETHER EXPRESSED OR IMPLIED, OR ARISING BY OPERATION OF LAW, TRADE USAGE, OR COURSE OF DEALING, ARE HEREBY DISCLAIMED. (F) NOTWITHSTANDING THE FOREGOING, THERE ARE NO WARRANTIES WHATSOEVER ON ITEMS BUILT OR ACQUIRED WHOLLY OR PARTIALLY TO THE BUYER'S DESIGNS OR SPECIFICATIONS.

15. Limited Remedy.

THE SELLER'S LIABILITY ARISING FROM OR IN ANY WAY CONNECTED WITH THE ITEMS SOLD OR THIS AGREEMENT SHALL BE LIMITED EXCLUSIVELY TO REPAIR OR REPLACEMENT OF THE ITEMS SOLD. IN NO EVENT SHALL THE SELLER BE LIABLE TO THE BUYER OR ANY THIRD PARTY FOR ANY INCIDENTAL, CONSEQUENTIAL OR SPECIAL DAMAGES OF ANY KIND OR NATURE WHATSOEVER, INCLUDING BUT NOT LIMITED TO LOST PROFITS ARISING FROM OR IN ANY WAY CONNECTED WITH THIS AGREEMENT OR ANY ITEMS SOLD, WHETHER ALLEGED TO ARISE FROM BREACH OF CONTRACT, EXPRESS OR IMPLIED WARRANTY, OR IN TORT, INCLUDING WITHOUT LIMITATION, NEGLIGENCE, FAILURE TO WARN OR STRICT LIABILITY. IN NO EVENT SHALL THE SELLER BE LIABLE TO THE BUYER OR ANY OTHER ENTITY FOR MORE THAN THE INVOICE PRICE RECEIVED BY THE SELLER FOR ANY NON-CONFORMING PRODUCTS. THE SELLER SHALL NOT BE LIABLE TO THE BUYER OR ANY OTHER ENTITY FOR PERSONAL INJURY, PROPERTY DAMAGE, OR ANY DIRECT, INDIRECT, SPECIAL, INCIDENTAL, CONSEQUENTIAL, PUNITIVE, EXEMPLARY, SPECIAL, OR OTHER DAMAGES OF ANY KIND, INCLUDING WITHOUT LIMITATION THE COST OF PROCUREMENT OF SUBSTITUTE GOODS, THE LOSS OF PROFITS, PRODUCTS, OR PRODUCTION, OR THE INTERRUPTION OF BUSINESS, HOWEVER CAUSED. THE SELLER SHALL NOT BE LIABLE TO THE BUYER OR ANY OTHER ENTITY ON ANY THEORY OF LIABILITY INCLUDING WITHOUT LIMITATION BREACH OF CONTRACT OR EXPRESS OR IMPLIED WARRANTY, TORT, NEGLIGENCE, FAILURE TO WARN, OR STRICT LIABILITY AND WHETHER OR NOT THE SELLER HAS BEEN ADVISED OF THE POSSIBILITY OF SUCH DAMAGES. THE ESSENTIAL PURPOSE OF THIS PROVISION IS TO LIMIT THE LIABILITY OF THE SELLER ARISING OUT OF THE SALE OF PRODUCTS TO THE BUYER WHETHER FOR BREACH OF CONTRACT, NEGLIGENCE, OR ANY OTHER THEORY OF LIABILITY. THESE LIMITATIONS SHALL APPLY NOTWITHSTANDING ANY FAILURE OF ESSENTIAL PURPOSE OF ANY LIMITED REMEDY AND NOTWITHSTANDING THE PROVISIONS OF ANY OTHER AGREEMENT BETWEEN THE SELLER AND THE BUYER.

16. Indemnity for Infringement of Intellectual Property Rights.

(a) The Buyer shall defend and indemnify the Seller against all actions, claims, demands, penalties and costs by third parties in tort, or for infringement, or alleged infringement, of patents, trademarks, copyrights, trade dress, trade secret or other rights of any third party resulting from the goods manufactured in accordance with the Buyer's specifications or based on any information provided by the Buyer. The Buyer will defend any action against the Seller for title, patent, trademark, copyright infringement, or other claimed by a third party at the Buyer's sole cost and expense. (b) The Seller shall have no liability for infringement of any patents, trademarks, copyrights, trade dress, trade secrets or similar rights except as provided in this provision. The Seller will defend and indemnify the Buyer against allegations of infringement of patents, trademarks, copyrights, trade dress and trade secrets ("Intellectual Property Rights"). The Seller will defend at its expense and will pay the cost of any settlement or damages awarded in an action brought against the Buyer based on an allegation that an item sold pursuant to this contract infringes the Intellectual Property Rights of a third party. The Seller's obligation to defend and indemnify the Buyer is contingent on the Buyer notifying the Seller within 10 days after sole control over the defense of any allegations or actions, including all negotiations for settlement or compromise. If an item sold hereunder is subject to a claim that it infringes the Intellectual Property Rights of a third party, the Seller may, at its sole expense and option, procure for the Buyer the right to continue using said item, replace or modify said items so as to make it non-infringing, or offer to accept return of said item and return the purchase price less a reasonable allowance for depreciation. Notwithstanding the foregoing, the Seller shall have no liability for claims of infringement based on information provided by Buyer, or directed to items delivered hereunder for which the designs are specified in combination or use in a system of any item sold hereunder. The foregoing in this provision shall constitute the Seller's sole and exclusive liability and the Buyer's sole and exclusive remedy for infringement of Intellectual Property Rights.

17. Lien.

In addition to any right of lien to which the Seller may by law be entitled, the Seller shall have a general lien on all goods of the Buyer in the Seller's possession (although such goods or some of them may have been paid for) for the unpaid price of any other goods sold and delivered to the Buyer by the Seller under the same or other contracts.

18. Waiver.

The Seller's rights shall not be affected or restricted by any indulgence or forbearance granted to the Buyer. No waiver by the Seller of any breach shall operate as a waiver of any later breach.

19. Force Majeure.

The Seller shall be excused from performing any of its obligations under this Agreement which are prevented or delayed by any occurrence not within the reasonable control of the Seller, including but not limited to, accidents, acts of God, destruction or damage to the goods or the Seller's manufacturing plant, delays or failures in delivery of carriers or suppliers, shortages of materials, strikes or other labor matters, floods, earthquakes, fire, riots, explosions, or any regulations, rules, ordinances or orders of any governmental authority, federal, state or local, whether such cause exists at the date of the order or not.

20. Buyer's Representation of Solvency.

The Buyer hereby represents that as of the signing of this Agreement it was not insolvent within the meaning of the Uniform Commercial Code or any Bankruptcy Laws.

21. Assignment and Delegation.

The rights and obligations of the parties under this Agreement may not be assigned or delegated, except on the express written consent of the other party to the assignment or delegation.

22. Integration.

The rights and obligations of the parties and the terms and conditions set forth herein, together with any amendments, modifications and any different terms and conditions expressly accepted by the Seller in writing, shall constitute a complete and exclusive statement of the terms of this Agreement. This Agreement supersedes not only all prior agreements, but also oral agreements made contemporaneously with the execution of this Agreement. All such materials may not be used to supplement, explain, or contradict the terms of this Agreement.

23. Severability.

If any of these conditions or any part thereof purports to exclude or restrict or limit any liability and such exclusion or restriction or limitation is prohibited or rendered void or unenforceable by any legislation to which it is subject, or is itself prohibited or rendered void or unenforceable by any legislation to which it is subject, then the exclusion, restriction or limitation on the condition or part thereof in question shall be so prohibited or rendered void or unenforceable and the validity or enforceability of any other part of these provisions shall not thereby be affected.

24. Governing Law/Limitation on Actions.

The terms, conditions, rights, and obligations under this Agreement shall be construed under the laws of the State of California, without regard to principles of conflicts of laws. No actions arising out of the sale of the items sold hereunder or this Agreement may be brought by the Buyer more than two (2) years after such cause of action accrues.

Notes: