

# Qt™ 300/600

## Installation & Operations Guide

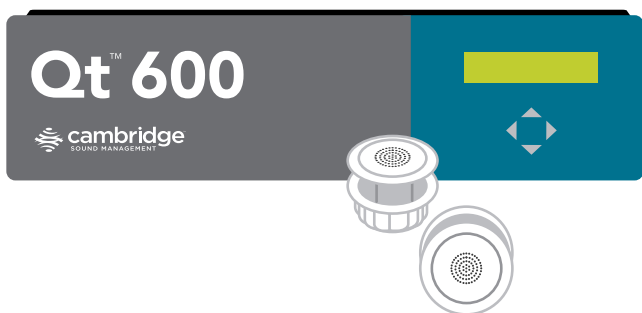

# Qt™ 300/600 Quick Installation Guide

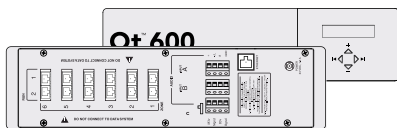

1

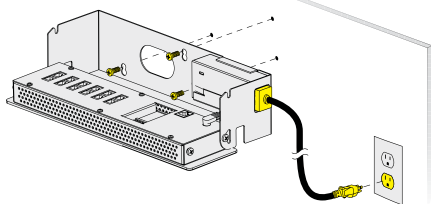

3

2

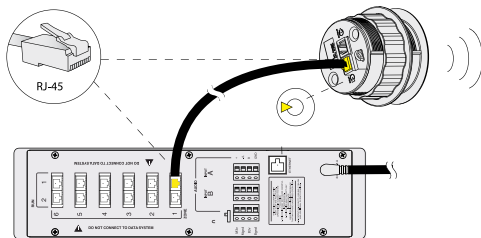

4

3

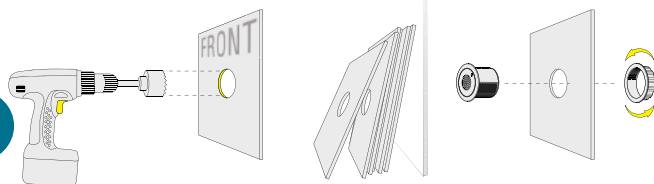

4

4

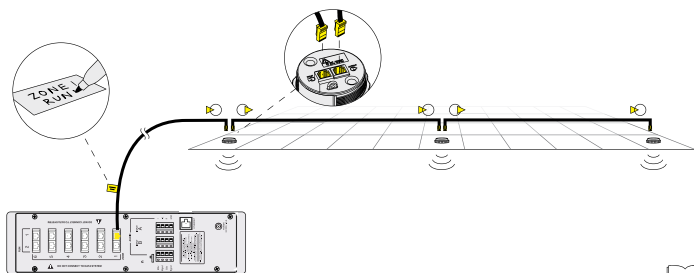

5

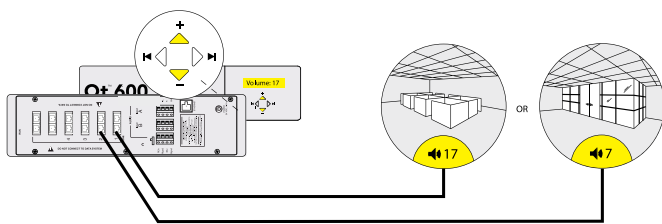

6

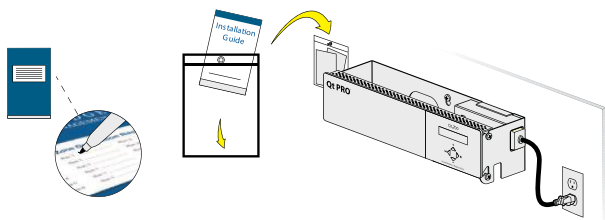

# Contents

Safety Information	6
Qt 300/600 Introduction	7
Hardware Installation	9
Installing the Control Module	9
Wall Mount	9
Rack Mount	10
Installing Qt Emitters	11
Emitter Installation Order	11
Installing Paging or Music to the Audio Inputs	13
Installing Contact Closures	13
Custom Cabling Guidelines	14
Battery Replacement	15
System Configuration (Front Panel and Monitor Control Software)	16
System Configurable Feature List (Front Panel / MCS)	16
Configuring the Control Module for the Network	17
IP Address DHCP	17
NETBIOS Support	17
Other Recommended Connections	17
Suggestions for Managing Multiple Control Modules	17
Front Panel Control	18
System Information	18
Setting Sound Masking Levels	19
Setting Audio Input Levels	21
Lock/Unlock the Front Panel	21
Configure Network Name and IP Address	22
Real-Time Clock or Network Clock	22
Reset System to Default Settings	22
System Control Using Monitor Control Software (MCS)	23
Connecting to the Qt 300/600 over Ethernet	23
MCS: Operation Section	24

Changing Masking Level Using MCS	25
Auto Ramping	25
Changing Input A and B Level	26
Time of Day Masking	27
Errors	28
MCS: Administration Section	28
Service	29
Zone Names	29
Networking and Security	29
Notification of Errors	29
Date and Time – Time Zone	30
Setting Equalizers and Emitter Fault Detection	31/32
MCS: Help	34
Links to Help Topics	34
Software Update	34
Documentation	35
MCS: Printout	35
Error Codes and Message	35
Post Installation Handoff	37
Warranty	38
Settings Record	40
Notes	41
Homerun Zone Destination Record	43

# Safety Information

- 1) Read these instructions.
- 2) Keep these instructions.
- 3) Heed all warnings.
- 4) Follow all instructions.
- 5) Do not use this apparatus near water. Indoor use only.
- 6) Clean only with dry cloth.
- 7) Do not block any ventilation openings. Install in accordance with the manufacturer's instructions.
- 8) Do not install near any heat sources such as radiators, heat registers, stoves, or other apparatus (including amplifiers) that produce heat.
- 9) Use only power supply provided with the unit.
- 10) Do not defeat the safety purpose of the polarized or grounding-type plug. A polarized plug has two blades with one wider than the other. A grounding type plug has two blades and a third grounding prong. The wide blade or the third prong is provided for your safety. If the provided plug does not fit into your outlet, consult an electrician for replacement of the obsolete outlet.
- 11) Protect the power cord from being walked on or pinched particularly at plugs, convenience receptacles, and the point where they exit from the apparatus.
- 12) Only use attachments/accessories specified by the manufacturer.
- 13) Unplug this apparatus during lightning storms or when unused for long periods of time.
- 14) Refer all servicing to qualified service personnel. Servicing is required when the apparatus has been damaged in any way, such as power-supply cord or plug is damaged, liquid has been spilled or objects have fallen into the apparatus, the apparatus has been exposed to rain or moisture, does not operate normally, or has been dropped.
- 15) This product contains a lithium battery that is not user replaceable. The battery may be replaced by qualified service personnel only.

## CAUTION

Danger of explosion if battery is incorrectly replaced.  
Replace only with the same or equivalent type.

# Qt 300/600 Introduction

This manual discusses the installation of a sound masking system using either the Qt 300 or the Qt 600. The Qt 300 and Qt 600 controllers have identical functionality, but different number of zones supported - the Qt 300 supports 3 zones whereas the Qt 600 supports 6 zones. As you use this guide, remember the number of zones and total area of coverage is the only real functional difference between the systems. Collectively, the systems are referred to as 'QtPro' throughout this guide.

The Qt 600 supports six zones of sound masking, each with 1 to 120 emitters covering 100 to 12,000 square feet (9.3 m<sup>2</sup>) - 1,115 m<sup>2</sup>) per zone. The Qt 300 supports three zones of sound masking, each with 1 to 120 emitters, covering up to 12,000 square feet per zone (1,115 m<sup>2</sup>). Each systems comes with two audio inputs which can be used for paging and/or music. Additional controls for each zone include time-of-day masking, auto ramping, self-monitoring fault detection and notification, and independent equalizers for masking and audio inputs. The system may be operated from its control module front panel OR by a computer directly-connected to the module OR by a computer connected through a local area network. See system configuration on page 16.

It is important that the control module's masking volumes be set correctly for each zone to obtain the full effectiveness of the system. If volumes are set too low, speech privacy will be reduced and work place distractions will be much more apparent. If volumes are set too high, the masking sound itself could become a source of distraction. The higher the setting that can be used comfortably, the better the acoustic privacy. For a given open office design, including ceiling height, ceiling material and workstation panel height, we can define the masking volume required to achieve "normal acoustic privacy," i.e., when it is relatively easy to ignore surrounding conversations. For a very large range of open office designs, the target level is in the 45–48 dBA range, measured 3 ft (0.9 m) above floor level. Similarly, for private offices, based on wall panel design and ceiling construction, we can define masking volumes required to achieve "confidential privacy," i.e., conversations in adjacent offices cannot be understood. Most private offices have a target level in the 38–42 dBA range, averaged spatially within the office.

Setting the masking volumes can be approached in one of two ways:

**BEST:** If a sound level meter is available, it is recommended that the control module's masking volumes be adjusted up or down to achieve the following readings on the meter:

**Private Office Zones**

38-42 dBA, averaged spatially within the office

**Open Area Zones**

45-48 dBA, measured 3 ft (0.9 m) above floor level

**OTHERWISE:** If a sound level meter is not available, the above levels are likely to be achieved in most environments by setting the control module's masking volumes as follows:

**Private Office Zones**

05-09, for all ceiling heights

**Open Area Zones**

13-16, for 8 ft (2.4 m) ceilings

15-18, for 10 ft (3 m) ceilings

17-20, for 12 ft (3.7 m) ceilings

Masking volumes must be set sufficiently high to improve speech privacy and reduce distraction but not so high that the masking sound becomes objectionable. Settings within the above ranges should accommodate both objectives. As a general rule, use the high end of the range. Base final settings on site conditions and customer preferences. If people object to the sound level, set masking volumes toward the bottom of the range or refer to the 'Ramping' section of this guide, found on page 25 for more information on introducing masking into the space gradually. Remember that the effectiveness of the system relies on sufficient masking sound level and that initial objections are often overcome as people become accustomed to the sound.

Different day and a night volumes may be set. The control module ramps linearly between these two settings beginning at the time specified and over the period of time specified. As the control module ramps between settings, the current volume is displayed under "Current."

**NOTE:** This document uses the QtPro software version 6.1.0 or higher for feature configuration.



# Qt 300/600 Introduction

## Installing the Control Module

**NOTE:** Always plug/unplug power supply at wall outlet

**NOTE:** The Qt 600 is shown in the figures, but the Qt 300 installs in the same manner.

### Wall Mount

Mount the bracket using the three screws and plastic anchors (mollies) provided. Use a ¼ inch drill bit for the anchor hole. See Figure 1.

Plastic anchors are #10-12 x 1¼ in with #10 x 1½ screws.

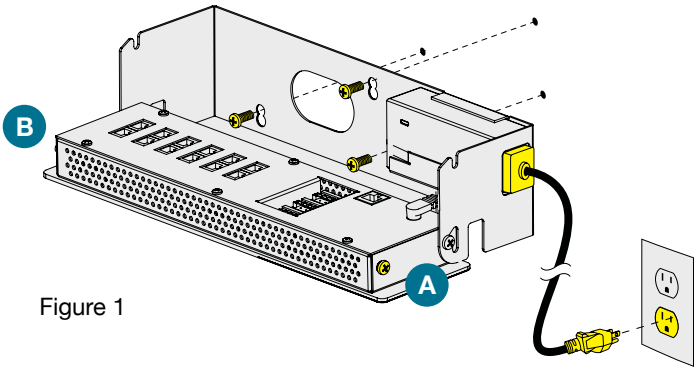
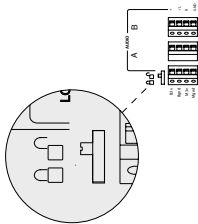

Figure 1

**NOTE:** The control module hinges forward for wall mounting and cable installation. To hinge forward, loosen screws A and B (see Figure 1) used to secure the module during shipping.



Check to see that the panel lock switch is in the UN-LOCKED position.

## Rack Mount

Attach optional rack mount brackets to each end of the control module.

**NOTE:** When rack mounted, the control module does not hinge forward.

### Step 1

Remove the QtPro and power supply bracket from wall mount bracket.

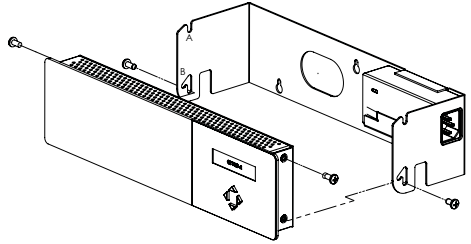

### Step 2

Reassemble power supply to right rack mount bracket using 6-32 black screws (included with bracket).

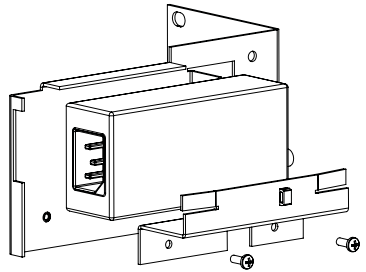

### Step 3

Fasten left and right rack mount brackets to QtPro using the screws removed in Step 1.

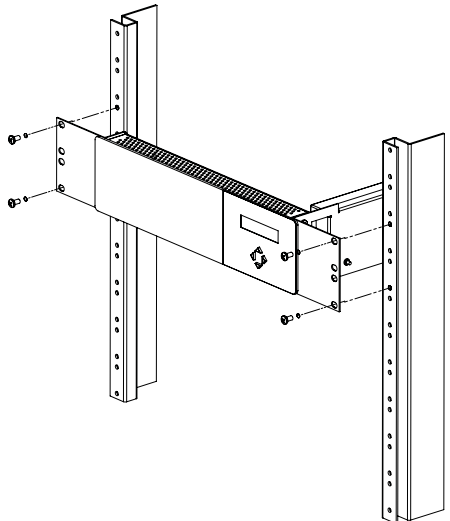

### Step 4

Mount QtPro to 19" cabinet rail using 10-32 screws as shown (included with bracket).

## Installing the Qt Emitters

### Important Considerations:

- Each run has a maximum of 60 emitters
- Each run should have a maximum length of 1000 ft (305 m).
- Each home run cable attached to the control module should be labeled by zone # and run #. Adding a logical name (e.g. Marketing, Private Offices) is suggested. In addition, fill out “Home Run Zone Destination Record” at the end of this Guide.
- Each zone has two identical outputs, run 1 and run 2. All emitters on run 1 and run 2 are controlled equally for each zone.
- Each job-made cable should be manufactured according to ANSI/TIA/EIA Standard 568-B. See custom cabling guidelines on page 14.
- Job-made cables should be tested with a LAN tester before installation. Adjustable emitters should be set for lower sound levels, within a zone, when sound level measurements show an acoustically loud subsection.

### Emitter Installation Order

1. Set the masking output level of all zones to level 20.
2. Refer to the emitter layout and wiring diagram provided by the dealer for cable run connections by zone.
3. Run home run cables from control module to the location of the first emitter for all runs in all zones.
4. Gather all ceiling tiles (per layout drawing) that are to receive emitters. Use the supplied hole saw to cut holes in designated tiles. Cut all tiles from the front. (Different types of emitter housings are available to attach in areas where there are no suspended ceiling tiles.)
5. Push the emitter through the front of the hole in tile and secure it by pushing down and twisting the locking ring at the back of the emitter.
6. Connect a run cable from the specified zone OUTPUT jack on the module to the INPUT jack of the first emitter. Listen to each emitter as it is connected. If you cannot hear its “whooshing” sound:
  - a. Try a different emitter.
  - b. Test all four previous cables for continuity and shorts. Repair any faulty cables.
  - c. If there is a short, circuit protection will engage, and masking volume will shut off. Once the short is fixed, the protection state should clear itself in approximately five minutes.

**NOTE:** The “tombstone” hook on the back of each emitter is next to the INPUT jack. This can help you find the INPUT jack by touch.

**NOTE:** To adjust for unexpected obstacles such as sprinkler heads, each emitter may be moved up to two feet (one tile) in any direction, if necessary.

7. Connect the next OUTPUT cable to the emitter OUTPUT jack.
8. Run the cable to next designated tile specified on emitter layout and wiring diagram. Tie cables up to structure or suspend from deck as required by local building code.
9. On the next emitter, connect this cable to the INPUT jack.
10. Repeat Steps 4 through 9 for the remaining emitters on the home run.
11. Set sound masking volume levels for each zone, using either the front panel controls or the software interface. Set sound levels according to Table 1.
12. If a small area within a zone exhibits a perceived volume louder than the rest of the zone, use the adjustable emitter toggle switches to turn the volume down for the emitters in that area. Emitters can decrease volume by 3, 6, or 9 dB. See emitter spec sheet for more details.

Be sure to fix any problems and hear the “whooshing” sound before installing the next emitter. If necessary see the Errors section of this guide, found on page 28.

**Note:**



The input jack of each emitter bears this symbol and is located near the safety tie off



The output jack of each emitter bears this symbol

**Table 1**

Zone Type	Ceiling Height	Vol. Level	Intended Result (at listener ear level)
Open Area	8'	13 - 16	45 - 48 dBA
Open Area	10'	15 - 18	45 - 48 dBA
Open Area	12'	16 - 19	45 - 48 dBA
Private Office	ALL	05 - 09 +	38 - 42 dBA

## Installing Paging or Music to the Audio Inputs

1. Be sure power is OFF by unplugging power cord from wall outlet.
2. Balanced Audio Input: (most often, but not always characteristic of paging systems.) Connect signal wires to + and - at input A or B. Connect the shield to GND at the audio source.
3. Unbalanced Audio Input: (typical of music systems.)
  - a. Mono Signals: Connect signal wire to both L and R at input A or B. Connect the ground wire to GND.
  - b. Stereo Signals: Connect signal wires to L and R at input A or B. Connect the ground wire to GND.
4. If a music source is to be connected, using Input B allows emergency music shut-off. See Contact Closures below.

## Installing Contact Closures

The QtPro provides an instant shut-off capability for masking and/ or audio Input B if connected to a contact closure interface. The contact closure utilizes the same style connector as audio Inputs A and B (4-pin).

To leverage this feature for masking, connect a two-conductor cable to the two connectors, labeled M3V and MGND. To leverage this feature for Audio Input B, connect a two-conductor cable to the two connectors, labeled B3V and BGND.

The other end of these conductors (treated as pairs/circuits) can be terminated on closure mechanisms of choice.

1. To shut off masking, form a connection between the two "M" conductors.
2. To resume masking, break the connection (Don't break the connectors as you may want to reuse them).

The contact closure for audio Input B follows the same logic.

## Custom Cabling Guidelines

For system compliance, follow these guidelines if custom cables are required:

1. Use solid conductor 24 AWG CAT cable that meets local code requirements.
2. If the system is installed in a return air plenum, the cable must be plenum rated.
3. Shielding is not required. Unshielded twisted pair (UTP) cable is acceptable.
4. Snagless boots are not required.
5. RJ-45 plugs must use the "bent 3-tine" RJ 45 plugs intended for use with solid core CAT wire. Three tine plugs can be purchased at a hardware store and from most CAT cable suppliers. DO NOT USE the "aligned two-tine" type intended for stranded wire, as they provide improper contact and may yield intermittent system operation. The diagram below shows the end-on view of both types.
6. Field test each cable after fabrication with the RJ-45 connectors (before final installation), using a standard network LAN cable tester, to check for continuity, shorts, and 1:1 (straight through) connection.

Figure 2

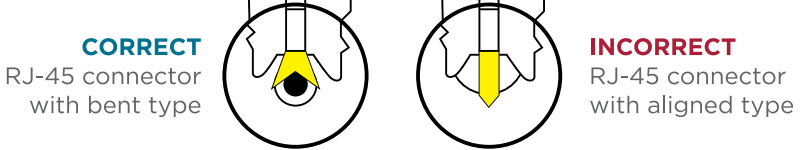

# Battery Replacement

A coin-style battery (Cr1220 or Br1220) powers the real time clock during a power loss.

To replace the battery:

1. Unplug the control module from wall outlet.
2. Hinge the control module forward to access the connection panel.
3. Remove the zone run connections. They should already be labeled, if not, label before removing (for example: Zone 1 Run 2).
4. Remove the six screws that hold the panel.
5. Taking care not to disturb the other connections, lift the panel to expose the coin battery in its housing at the front left of the module.
6. Use a ball-point pen to dislodge the existing battery.
7. Insert a new battery with the positive (+) side facing upward.
8. Replace the connection panel, securing all six screws. Reconnect the zone run cables.

Figure 3

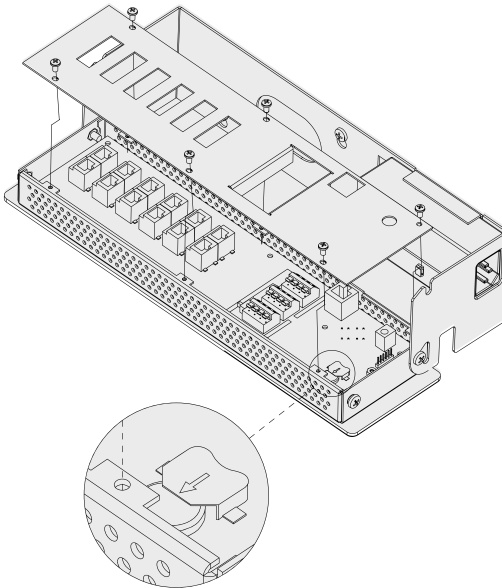

# System Configuration

After the QtPro is mounted, the power can be turned on and settings modified to test wiring to the connected emitters. After testing, it is time to configure the controller for operations. There are two methods for performing configuration:

1. The front panel display can be used for basic configuration settings to get the system working and tested. In many cases, basic settings are all that a user needs. This interface only supports a subset of the functionality.
2. The MCS (Monitor Control Software) interface allows for configuring all the available functionality. The MCS can be used with any internet browser that can connect to the Qt 300/600 over a LAN connection. See System Control Using MCS on page 23 for details.

## System Configurable Feature List (Front Panel / MCS)

The following is a complete list of the Qt 300/600 features and if they can be configured through the front panel, MCS or both.

<b>Feature</b>	<b>Front Panel</b>	<b>MCS</b>
Set masking level for each zone independently	X	X
Setting audio input levels at each zone	X	X
Setting real-time clock or network clock use		X
Reset system to default settings	X	
Configure network name and IP address		X
Set Time of Day Masking		X
Set Masking Ramp Period (Initial and Daily)		X
Set Masking Equalization		X
Viewing errors	X	X
Configuring error notification		X
System/Software version Information	X	X
Emitter Fault Detection		X
Networking and Security Administration		X
Software Update		X
Contact Closure (hardware only)		
Lock/Unlock the front panel (hardware only)		



## Configuring the Control Module for the Network

### IP Address DHCP

The IP address is preset for systems that are not on the network. To directly connect to the control module over Ethernet, the user uses any internet browser and places the IP address or control module name in the navigation bar.

If the MCS is not used, DHCP will allocate an IP address when the system is connected to the network. This field can be statically set through the MCS, but it will be dynamically allocated when MCS is not used.

### NETBIOS Support

The system supports NETBIOS and advertises its hostname as QtXX, where XX is the last two digits of the MAC address.

### Other Recommended Connections

Access to an SMTP server enables the sending of error notification emails.

Access to an SNTP server obtains the SNTP time stamp. If the SNTP server is enabled, the real-time clock feature is disabled. A time server other than the default time server may be specified in the Administration section under date and time.

### Suggestions for Managing Multiple Control Modules

Browser bookmarks are a convenient tool for managing multiple control modules. A bookmark add-on stores bookmarks on a web server and allows access from any computer on the LAN.

Create a "Sound Masking" folder (under Bookmarks) to hold a bookmark for each control module. Use location-based names for each module's bookmark. To access a specific control module, open Bookmarks>SoundMasking, and the specific module bookmark.

## Front Panel Control

The front panel is used for configuring basic functionality and initial system test. For advanced system configuration, the MCS is required. Once the MCS is used to configure the system, using the front panel will erase the settings configured by the MCS. Once the MCS is used to configure the system, it should be used exclusively.

## System Information

Initial displays of the front panel, shown below, shows the software version and system status.

The VERSION X.X.X field stands for:  
*major release . minor changes . bug fixes.*

The HxBx field is to identify the version of the internal code and used as reference for technical support on rare occasions.

```
VERSION X.X.X  
Status: OK HxBx
```

Status indicates if there are errors (see error codes, page 35) or if the system is OK. The HxBx field indicates the version of the internal code images and is only used by Cambridge Sound Management when debugging a problem.

The MAC address is displayed for reference when the system is on the network. The network administrator will need this when configuring a network connection.

Shown in the next block is the display for the IP Address. This is a default value that can be used in a browser, for direct connection. As noted, DHCP will change it when the system is on a network

```
IP Address DHCP  
169.254.1.1
```

Hostname is set at the factory to a default value.

```
Host Name
QT XX
```

The next 2 blocks show the username and password when connecting using MCS. The default is admin/secret.

```
Username
admin
```

```
Password
secret
```

A warning message is displayed on the front panel after the MCS is used for configuration (Warning: Time of day Ops). This tells anyone about to use the front panel that the MCS has been used for configuration and using the front panel will reset the settings made by the MCS.

### Setting Sound Masking Levels

```
Masking
Z1 Volume: Mute
```

Figure 10: The format of the panel for configuring masking. Z1 stands for zone 1 and it is currently set to mute.

See the Introduction section for recommended volume settings.

Settings within the recommended ranges should optimize speech privacy without excessive distractions. Generally, set masking volumes toward the high end of the range and adjust according to site conditions and user preferences. If possible, measure the results with a sound level meter and check for the achieved sound pressure level. Adjust as necessary or judge by listening in the area.

If installation occurs before the office is occupied, turn the system to the desired level and leave it at that level. If the system is installed after the office is occupied, turn the system to the correct level when the space is unoccupied and employ auto ramping, only supported through the MCS, to provide for a period of acclimatization.

To set the masking level for a zone, use the arrow keys on the front panel to move to the right until the zone of interest is shown (Z1 is zone 1 which matches the first column of ports on the back). Then use the up and down arrows to change the value.

After setting the value for one zone, arrow to the right or left to set the value for zone of interest. Repeat for all zones. If a portion of a zone is louder than the rest of the zone due to a difference in acoustics, it should either be a different zone or the volume lowered using the adjustment on the back of the emitters. The volume will still change based on the value of the controller, but the output can be turned down 3, 6, or 9 dB from the value set at the controller.

#### **IMPORTANT:**

For full system effectiveness, it is essential to set the volumes correctly for each zone.

If the volume is set too low, speech privacy is reduced and workplace distractions are more apparent.

If too high, the masking sound can become a distraction. Since, in general, acoustic privacy improves as sound masking volume increases, the general strategy is to set the masking volumes as high as possible without being distracting.

## Setting Audio Input Levels

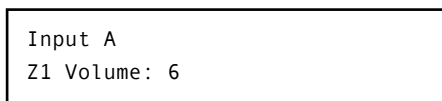

This figure shows the format of the panel for configuring the volume for input A or B. The level of the input is set for each zone, where the example shows Input A is level 6 for zone 1.

The system has two inputs for paging or music. Either input may be connected to any or all zones via software or front panel interface. If no paging and/or music from these inputs are desired in a particular zone, set the audio volume level of that zone to mute.

Note that Input B is the preferred music input due to its ability to be shut down via a contact closure.

The audio input levels are set in a similar way as the masking. Use the arrows on the front panel to move left and right to find the input A and input B field for each zone. The inputs are enabled and level set for each zone for flexibility. Arrow to each zone for each input and set the level using the up and down arrows.

### Lock/Unlock the Front Panel

The settings of the Qt 600/Qt 300 can be locked by a physical switch on the back of the control module. Lock the control module panel by moving the "lock" switch to the "Locked" position. This prevents any casual interaction from changing the settings.

### Unlock the Front Panel and Control the System

1. Loosen screws and lift the control module slightly and hinge it forward to give access to its connection panel.
2. Move the panel lock switch to the UNLOCKED position. Close the module.
3. Press NEXT or PREVIOUS to scroll between screens for adjusting sound masking, paging or music volumes by zone.
4. Modify a value by 1 dB on any screen by pressing + or -.
5. Press NEXT to accept a screen value.
6. After completing adjustments, lock the system.

**NOTE:** The system returns to the Version, Status screen after five minutes of inactivity. Z1 indicates Zone 1, Z2 indicates Zone 2, etc. If an error is detected, an error code is displayed on the control module. See page 35 for details about Error Codes.

## Configure Network Name and IP Address

Creating a static IP address or controller name is not available from the front panel. The MCS software can configure both the network name and the IP address (see below). If the system is not connected to the network, the initial values shown on the front panel are used when connecting a PC to the QtPro over Ethernet.

If the QtPro is connected to the network, a DHCP server will dynamically allocate an IP address. The system MAC address is used by the network system administrator to configure the DHCP server.

**NOTE:** When connecting a PC directly to the control module, the control module acts as a DHCP server and serves the DHCP enabled PC and IP address.

## Real-Time Clock or Network Clock

If the QtPro is not connected to the network, it will use a real-time clock within the controller. This requires the battery for power. This is often the way time is supplied to the QtPro.

If the QtPro is on the network, time and date will be acquired via SNTP and saved to the real-time clock. If the QtPro is off the network, time and date are acquired from the onboard real-time clock.

**NOTE:** When the QtPro is configured in the factory the date and time is set to Jan 1. Basic operations will work without changing this time. For any advanced features that require the time of day, either the network clock or correct setting of the time is required.

## Reset System to Default Settings

To clear an error indication (after problem is fixed) or reset the settings to the initial default state, the system should go through a hard reboot.

### Steps for the hard reboot:

1. Unplug the power and wait 15 seconds or more.
2. Hold the up arrow on the front panel and re-connect power. Release the up arrow once the LCD display shows it is booting.

## System Control Using Monitor Control Software (MCS)

The MCS (Monitor Control Software) is an interface that configures the QtPro over a LAN/network connection. The MCS software is operated from any network browser. Below are the instructions to connect to the control module over Ethernet locally and over the network.

After the discussion on connecting to the control module, the MCS screens will be discussed.

### Connecting to the Qt 300/600 over Ethernet

1. System software is operated from any network browser. Software is pre-installed in the control module. The HELP function provides comprehensive software control operating instructions.
2. Connect a computer or the network to the 10/100 Ethernet jack.
3. Power the control module on by plugging it into a standard wall outlet.
4. Press the right arrow on the control module to advance to the IP address screen. An assigned IP address is displayed on the front panel within two minutes of powering the module.
5. Access the Qt System Monitoring and Control Software
  - a. Read the control module Hostname or IP address from the front control panel.
  - b. Enter either the hostname or IP address into the browser address bar.
  - c. A prompt will appear requiring a username and password.
  - d. The default username is "admin". The default password is "secret".
6. After logging in with the defaults, you may change the hostname, username and password.

### DHCP Support

The system uses DHCP to obtain an IP address.

The system displays its MAC address on the front panel. This allows the network administrator to use the MAC address to configure the DHCP server to deliver a fixed (static) IP address to the control module.

# MCS: Operation Screen

The screenshot shows the 'Operations' section of the Cambridge Sound Management interface. At the top, there is a navigation bar with 'Operations', 'Administration', 'Help', and 'Printout' buttons. Below this, there are 'Settings' and 'Emitter Network Fault Detection' links. The main content area has 'REVIEW' and 'MODIFY' buttons. The 'Zone 1' section displays a table with columns for 'Max', 'Min', and 'Current' values for 'Masking', 'Input A', and 'Input B'. The 'Time of Day Masking' section shows a table with columns for 'Time (Hour and Minute)' and values for 'Begin Ramp to Max', 'Begin Ramp to Min', 'Ramp Interval', 'Friday Schedule', 'Saturday Schedule', and 'Sunday Schedule'. On the right, there is a status indicator 'Jun 4, 2015 : 10:58 AM SNTP Status: OK' and a list of zones from Zone 1 to Zone 6.

Figure 12: Operations Section in review mode.

**Note:** The software version is displayed at the bottom right of every screen. The 3 digits indicate major release version, minor feature changes and bug fixes. There are times when Cambridge Sound Management will release software to fix unique bugs or small feature changes, and later roll them in to a major release. When a customer reports a problem, the software version number is usually requested. The Qt 300 will only differ on this screen by the number of zones shown. The Qt 600 will display six, while the Qt 300 will only display three.

The screenshot shows the 'Operations' section of the Cambridge Sound Management interface in modify mode. The navigation bar and status indicator are the same as in Figure 12. The 'REVIEW' button is disabled, and the 'MODIFY' button is active. The 'Apply To Zones' section shows a list of zones from 1 to 6, with 'showing 1'. The 'Masking' section has dropdown menus for 'MUTE', 'MUTE', and 'Mute' for 'Max', 'Min', and 'Current' values, and a dropdown for 'Auto Ramping (Commissioning)' set to 'Off'. There are 'Mute' and 'UnMute' buttons. The 'Time of Day Masking' section has dropdown menus for 'Begin Ramp to Max', 'Begin Ramp to Min', 'Ramp Interval', 'Friday Schedule', 'Saturday Schedule', and 'Sunday Schedule'. There are 'Submit' buttons at the bottom of both sections. On the right, there is a list of zones from Zone 1 to Zone 6, each with a checked checkbox, and an 'Unselect All' button.

Figure 13: Operations Section in modify mode

The Operations Section contains two blocks. The block on the left allows the configuration of:

- Masking level for min and max outputs.
- Sound level for auxiliary audio inputs A and B.
- Auto ramping.
- Mute and Unmute Control

The block on the right allows for the configuration of:

- Ramping start times.
- Ramping interval.
- Weekend ramping schedule.



## Changing Masking Level Using MCS

Follow these steps to update the parameters within the masking level block:

1. Review – selecting the review button will allow the user to select a zone and see the current configuration. Click on the zone on the right side of the operations screen.
2. To modify a zone, start by clicking the modify button.
3. Select the zones to modify by checking the boxes of the zones on the right side of the operations screen.
4. To set the masking level, use the multi-select for max. and min. settings in the left box.
5. Select Submit to commit the values.

**NOTE:** Only modify one block at a time and then click submit. If you modify both zone masking and Time of Day, only one window is updated. The suggested volume setting is discussed earlier in the Introduction section.

If a portion of a zone is louder than the rest of the zone due to a difference in acoustics, it should either be moved to a different zone, or the volume should be lowered, using the rocker switch adjustment on the back of each of the emitters.

## Auto Ramping

The Auto Ramping function is typically used once, when the system is first installed. The Auto Ramping function is used to introduce sound masking into an occupied space gradually. The Auto Ramping function sets the operational volumes for a zone a specified number of dBA below its programmed value. The control module will raise the zone's operational level by 1 dBA per weekday until the Auto Ramping value is back to zero and the zone is operating at its specified "Max" and "Min" values. If the system is running "quiet," check that Auto Ramping has been set properly. The Auto Ramping control is also a useful means of temporarily lowering the volume in a zone. This may be necessary if, for instance, there is a problem with some other electrical or mechanical system and maintenance needs absolute quiet to listen for the source. By using the Auto Ramping control, if the administrator forgets to shut off auto-ramping, the control module will gradually ramp back to the operational levels. If the administrator had "Muted" the zone using the Mute Button, masking would remain off indefinitely until someone set off to correct the problem.

Example: Zone 1 is planned to be masking level 9. Auto Ramping is set to -15dB. On day one, the level is active 15dB less than the planned level. Day 2, it is only 14 dB lower. It rises each day until it is functioning at full masking.

## Changing Input A and B Level

The control module operates as a paging amplifier. Refer to the control module's specifications for the electrical characteristics of Inputs A and B. Each signal is routed to all zones. The (acoustical) output level for each signal can be specify for each zone. Set a Zone/ Input A/B output level to "Mute" if you do not wish to connect the signal to the zone.

**NOTE:** Input B is the preferred music input due to its ability to be shut down via a contact closure.

The audio input levels are set in a similar way as the masking. Within the Operations window, each zone has a selector for the level of input A or B.

1. Select the modify button.
2. Select the zones to modify on the right by clicking the box.
3. Change the value in the left window.
4. Select Submit.

## Auxiliary Line Level Adjustment

From the operations tab and the zone block (shown in figure 13), selecting the Input A or Input B link in the window will open the window shown below. This allows the incoming level on the auxiliary input to be left at line level or increased by 10 dB in the case that the line level is below typical AV line level -10 dBv to +4 dBv.

The screenshot displays the Cambridge Sound Management web interface. At the top left, the logo for Cambridge Sound Management is visible, along with the text "Qt Quiet Technology System Monitoring and Control". On the right side of the top navigation bar, there are buttons for "Operations", "Administration", "Help", and "Printout". Below the navigation bar, there are links for "Settings" and "Emailer Network Fault Detection". The main content area shows a modal window titled "Input A/B Sensitivity". Inside this window, there are two dropdown menus: "Input A" and "Input B", both currently set to "LINE LEVEL". Below these menus is a "Back" button, and at the bottom right of the modal is a "Submit" button.

Select Line Level to use the signal as it comes to the controller and adjust volume from the zone window. Use Boost to add 10 dB to the signal and then continue the adjustment of volume in the zone window.

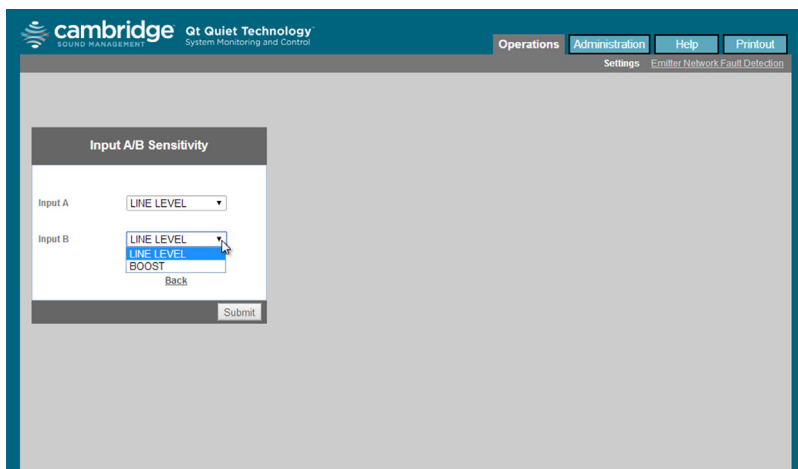

## Time of Day Masking

QtPro allows the specification of a max time masking volume and a min time masking volume for each zone. This allows complete flexibility to when the masking level needs to be high or low. Use the pull down menus to specify each start time and the ramping interval - the period of time allotted to accomplish the full, linear (in 0.5 dB increments) transition. QtPro also allows you to specify Friday, Saturday, and Sunday operation. You can chose weekday operation (max/min) or min operation where the min volume is in effect for the entire (weekend) day.

QtPro obtains the time-of-day from either an Internet-based NTP time server using the SNTP protocol or from its onboard real time clock. QtPro requires the user to define the time zone in which the box is operating and the daylight savings time rules for that time zone. If you are unfamiliar with your time zone, or daylight savings time rules, a quick search on the Internet should help you find this information. Go to "Administration: Time Zone" to specify the control module's time zone and daylight savings time rules.

**NOTE:** NTP timer servers do not provide time zone or daylight savings time rules and therefore these values **MUST** be specified by the administrator.

## Errors

If the control module is operating properly, software will display "Status: Ok". If the control module encounters an error, software will display "Status: Error". Click on "Error" to obtain additional information. Click on "acknowledge" to clear the error (see Administration: Notification of Errors, page 29). If the error condition persists, the error will be signaled again after clearing the error.

**WARNING:** If a "System Thermal Fault" occurs, be sure that the control module is not exposed to conditions beyond its ambient air specification of 104°F, 40°C.

**WARNING:** In order to protect the electronic circuitry from damage, the control module introduces a delay after experiencing an amp short before turning the amp back on. A persistent short will result in the amp being turned off once again. Shorts are most likely to occur during installation of the system due to termination mistakes by the installer. Shorts are unlikely once the control module is operational.

## MCS: Administration Section

The following section will use figure 14 for reference.

The screenshot shows the Administration Section of the Cambridge Sound Management software. The interface is organized into several panels:

- Service:** Unit Name (Ballroom QT), Location (Back Wall), Serviced By (Cambridge Sound Management), Phone No. (617-349-3779). Includes a REBOOT button and a Submit button.
- Zone Names:** Zone 1 (Left Back Corner), Zone 2 (Left Center), Zone 3 (Left Front Glass), Zone 4 (Right Back Corner), Zone 5 (Right Center), Zone 6 (Right Front Door). Includes a Submit button.
- Date and Time:** Current date/time: Mar 6, 2014 : 9:59 AM SNTP. Date: Thursday, March 6, 2014. Time: 09:59. NTP Server: pool.ntp.org. Includes a Warning icon and a Submit button.
- Networking and Security:** Panel Lock (Unlocked), Use DHCP? (No), MAC Address (0050C20002C5), IP Address (192.168.88.99), Gateway (192.168.88.1), Netmask (255.255.255.0), Primary DNS (192.168.88.10), Secondary DNS (0.0.0.0), Hostname (QTC5), Username (admin), Password (masked). Includes a Submit button.
- Notification of Errors:** Email Address (jbluestein@csmt.com), Server Name (192.168.88.222), Port Number (25), Username, Password. Includes Test and Submit buttons.
- Time Zone:** GMT-05 Eastern Time, Second Sunday in March, First Sunday in November. Includes a Submit button.

Navigation tabs at the top include Operations, Administration (selected), Help, and Printout.

Figure 14: Administration Section

**IMPORTANT:** Only update one block at a time and press Submit! Changes to blocks that are not submitted will be lost if a different block is submitted.

## Service

The service window holds the following fields:

**Control Module Name:** This is just a reference name for the control module and is not used for networking. An example of an informative name is "120 Main Street - First Floor".

**Location:** This is a good reference to track where the control module is located when faults are detected. Faults can be sent via email and the control module's location can be useful.

**Serviced By:** This is for getting help when there are errors/ problems. The name of the service company can be stored. By default it is Cambridge Sound Management, but it could be changed to the installer.

**Phone No.:** Cambridge Sound Management (by default)

## Zone Names

Use this screen to provide informative names for each served zone. Examples of informative names are: "Reception", "Offices East", "Cubicles East", "Offices West", and "Cubicles West".

## Networking and Security

Use this screen to obtain the control module's MAC and IP Addresses, to change its NETBIOS hostname, and to change the username or password for logging in. If you change the control module's hostname, QtPro will automatically advertise its new NETBIOS name.

**NOTE:** If the control panel is locked (the toggle switch on the inside of the control module is set to the "locked" position), the control module cannot be controlled from its front panel. If it is unlocked, the control module's operational parameters can be modified from the control panel.

**NOTE:** The "Username" and "Password" specified under Administration: Networking and Security to control access to the control module over the network, and the "Username" and "Password" specified under "Administration: Notification of Errors" to log into an SMTP outbound mail server need not be identical.

## Notification of Errors

Use this screen to configure access to the mail server that will be used by QtPro for sending email messages notifying the system administrator of errors.

The "Email Address" is the address to which error notification emails will be sent by the control module. The "Email Server" and "Port" are the name (i.e., smtp.mymailservice.com) of the mail server and the port that it listens to for outbound SMTP. If authentication is required, fill in the "Username" and "Password." Otherwise, leave them blank. "Username" and "Password" represent the control module's email account on the specified mail server. If a username and password are specified, the email will arrive From: "Username." Otherwise, the email will arrive From: "Hostname."

To minimize the number of emails sent for intermittent errors (for example, amp thermal fault cycling in a system exposed to excessive heat), the control module will send one email per error, until the error is acknowledged. Once the error is acknowledged, a subsequent error will result in a new email. The administrator acknowledges errors by clicking on the "Acknowledge" link that appears under "Operations" when an error is present (see MCS Error Display, page 35).

Once you have configured your email parameters, you may test your configuration by asking the control module to generate a "test" email. To do this, click Test. An email will be generated and sent. If the email does not get through, you may need to modify your configuration or the configuration of your SMTP outbound relay (server).

### **Date and Time – Time Zone**

The QtPro can use a network clock or the RTC (Real-time Clock) in the unit. The date and time for the Real-time Clock are set within this window.

If the Real Time Clock is to be used, it should be set prior to adjusting operating levels. The Real Time Clock is set using the pull-down menus under "Administration: Date and Time". You MUST set the day-of-the-week (e.g. Sun, Mon, Tues, etc), the date, and the time. The RTC will only be used if the control module has been unable to access an external time server since it was powered on. This may be because the control module is not on a network or because the corporate network's firewall prevents access to the Internet based servers.

The source for the control module's time stamp is listed next to the time stamp as either "SNTP" (external time server - accessed via the "Simple Network Time Protocol" protocol) or "RTC" (Real Time Clock).

**WARNING:** Manually changing the RTC's time/date via the "Administration: Date and Time" window should not be attempted between the hours of 12:00 AM and 2:00 AM on DST transition days (two per year). Doing so could result in a missed "spring ahead" or "fall behind" event. Set the date and time before midnight on a DST transition day or after 2:00 AM on a DST transition day.

If the date is wrong following a power failure, and the system is relying on the internal real time clock (RTC) and not a network-based time server, it is likely that the RTC's battery is depleted. Replace the battery (see battery replacement, page 15). Reassemble the control module and then plug it back into the wall outlet. Reset the Real Time Clock.

### Setting Equalizers and Emitter Fault Detection

A special login password is required to gain access to the ENFD Screens: for control modules running firmware 6.0.0 and higher it is "prosecret". For control modules running firmware prior to 6.0.0 please contact Cambridge Sound Management to obtain the password(s) for your module(s). You will need to provide the Mac Address of each control module. See "Administration: Networking and Security" for the MAC Address or it can be seen on the front panel.

Below are the screens for emitter fault detection and equalizer settings when logged in with the second level password.

### Equalizer Update

After logging in with the second level password, the operations sections will have a block that includes the equalizer settings. The Masking and Audio equalizers are configured by the factory and should not need to be modified in most installations. However, if desired, the equalizers may be used to adjust the system to a different masking, paging, or music spectrum.

You may specify the gain for a tap in its corresponding box. All values are measured in dB and the range is +/- 12 dB, in whole number increments. To specify a negative gain, precede the number by a minus sign (for example, -2). Once you have specified all of the taps of interest, press "Submit." The values will be changed and saved, and the equalizer will redraw to provide a visual representation of your settings.

When an equalizer's settings are modified, the control module calculates and reports the impact the new settings have on speech privacy. The report is shown in the Masking Equalizer control box

and is stated in terms of change to the Privacy Index. A change must be at least 1% for it to display. The calculation is performed as specified in "ASTM International; Designation: E1130-02, Standard Test Method for Objective Measurement of Speech Privacy in Open Offices Using Articulation Index".

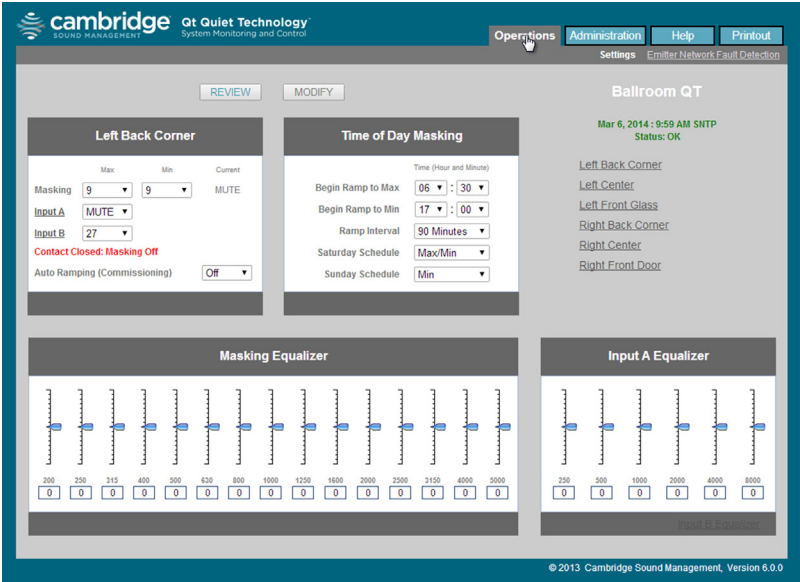

Figure 15: Operations Section with the equalizers block displayed after a higher level password has been entered.

## ENFD (Emitter Network Fault Detection)

The ENFD is a feature used after installation to monitor the status of the emitter cable runs. As shown on the screen, the installation should be complete without defect before the ENFD feature is enabled. The installation is complete by following the steps for installation, ensuring all the emitters are working and there are no error codes displayed.

The ENFD feature will start taking measurements of the cable runs after power is applied. It will take 15 minutes after booting to learn the emitter network and determine the steady state of the system.



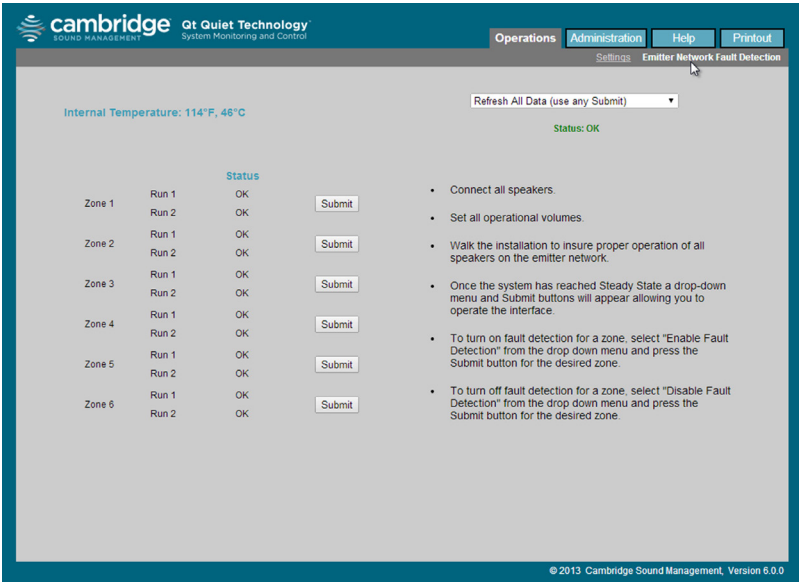

Figure 16: Standard view of the ENFD configuration section.

The diagram above shows the window as it appears and is learning the network configuration.

After the 15 minutes are expired and the system is fully installed, it is time to enable fault detection if you desire. It is not required for proper operation. The window shown on the next page shows that after the 15 minutes have expired there is a dropdown in the upper right corner that allows 3 actions:

1. Refresh settings - this is used just before enabling ENFD to make sure any setup data is cleared and proper measurements will be taken. This can also be used after an error has been fixed and a new test can begin.
2. Enable fault detection - once this is selected, select the zone in which you want the emitter run monitored, by choosing the submit button.
3. Disable fault detection - this is used to turn off the feature by then using the submit button for each run

If there is a fault, an error code 4 will be displayed for that failed zone in the status block.

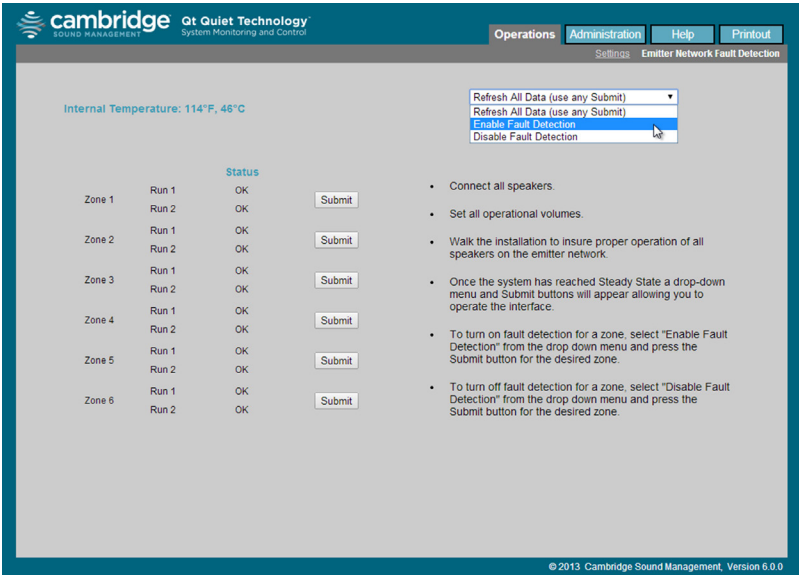

Figure 17: ENFD adjustment drop-down view

## MCS: Help

The following section will use figure 18 for reference.

### Links to Help Topics

From the Help screen on the MCS, there are links to some common questions when using the MCS. The links are shown on the right under Operations and Administration. This information is also contained within this document.

### Software Update

This is a link to the Cambridge Sound Management web site for access to the latest software. When the user selects the link from the MCS, it displays the current software on the control module and the version of software available to install.

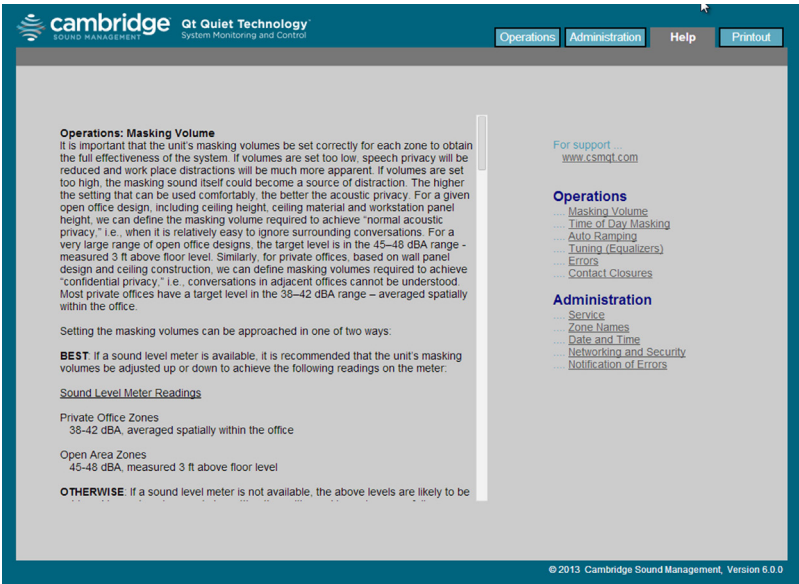

Figure 18: MCS Help Section

The install directions are provided with the new software for convenience and not part of this document.

## MCS: Printout

This screen displays the current configuration of the system. This screen should be captured and stored in case of data loss or system failure. Printing is done through the web browser print option.

## Error Codes and Messages

### *Front Panel*

System errors are shown on the control module front panel display. If an error occurs, the message "Status: Error" will be displayed. To determine the cause of the error, press NEXT. This displays the error screen with system error codes.

## Error Codes

If one or more errors exist in the sound masking system, an eight digit error code is displayed on the LCD display (scroll forward to the "Error" screen). The error state is indicated by an eight digit code of the form:

Error: 0\_000000

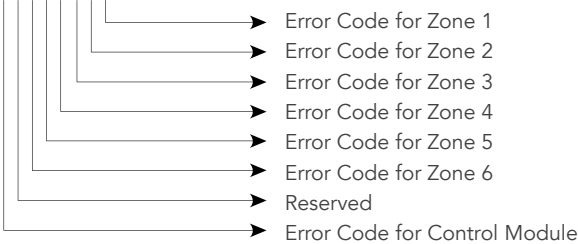

Where a number other than "0" indicates an error.

## Examples

- Error: 00000100 Short sensed in the wiring in zone 3
- Error: 00110000 Short sensed in the wiring in zones 5 and 6
- Error: 00000004 One or more emitters are not operating in zone 1
- Error: 80000000 Contact the manufacturer

## MCS Error Display

When there is an error in the system, the operations window will show a status in red as shown in the window below. Beside the status are the words "Error" and "acknowledge" which are described next.

The screenshot shows the MCS Error Display interface. The top navigation bar includes "Operations", "Administration", "Help", and "Printout". The main content area is divided into two panels: "Zone 1" and "Time of Day Masking".

**Zone 1 Panel:**

	Max	Min	Current
Masking	5	MUTE	5
Input A	15		
Input B	15		
Auto Ramping (Commissioning)	Off		

**Time of Day Masking Panel:**

	Time (Hour and Minute)
Begin Ramp to Max	08 : 00
Begin Ramp to Min	17 : 00
Ramp Interval	60 Minutes
Saturday Schedule	Max/Min
Sunday Schedule	Max/Min

**Status Message:** Feb 12, 2014 : 10:13 AM RTC  
Status: Error (acknowledge)

**Zone List:** Zone 1, Zone 2, Zone 3, Zone 4, Zone 5, Zone 6

Selecting "Error" for the screen above pops open a window that details the error in the system. The format of the error string is the same as shown on the front panel. The screen below shows there are emitter faults in 3 zones and the administrator should look for nonfunctional emitters.

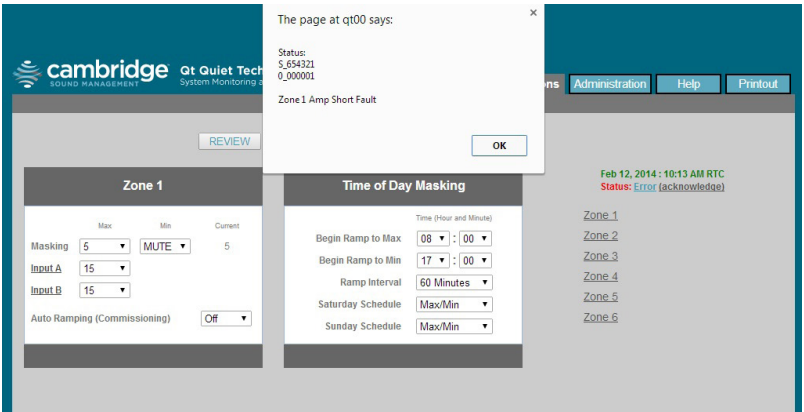

Click OK to close the window.

Click the acknowledge link and the status goes back to OK. If the error persists, the status will show the error. This can be used to test problem resolutions.

### Post Installation Handoff

Perform a final walkthrough to satisfy all aspects of the system performance:

1. Fill out the settings record.
2. Store guide with completed settings record in the clear plastic job ticket holder next to the control module. If there is a hard module failure, the recorded values can be used to reconfigure the system. System settings are retained after a power outage.
3. Lock the control module panel by moving the "lock" switch to the Locked position.
4. Lift the control module front panel and hinge it backward into its closed position. Tighten all retaining screws.
5. If operating by software control, show the administrator how to connect to the control module using both the Hostname and IP Address methods. Share this guide with the administrator.

# WARRANTY:

Note: This equipment has been tested and found to comply with the limits for a Class A digital device, pursuant to part 15 of the FCC Rules. These limits are designed to provide reasonable protection against harmful interference when the equipment is operated in a commercial environment. This equipment generates, uses, and can radiate radio frequency energy and, if not installed and used in accordance with the instruction manual, may cause harmful interference to radio communications. Operation of this equipment in a residential area is likely to cause harmful interference in which case the user will be required to correct the interference at his own expense.

Modifications not expressly approved by the manufacturer could void the user's authority to operate the equipment under FCC rules.

## Warranty Coverage — Qt® Emitters

Cambridge Sound Management, Inc. (the "warrantor") will, for a period of five (5) years, starting with the date of purchase, warrant that the Qt™ Emitters (the "speakers") will be free of defects in materials and workmanship that interfere with proper operation as a sound masking, paging and music speaker system. During that period, the warrantor will, at its option, either (a) repair the speaker, or (b) replace the speaker. The decision to repair or replace will be made by the warrantor.

## Warranty Coverage — Qt control unit

The warrantor will, for a period of one (1) year, starting with the date of purchase, warrant that the Qt control unit (the "system") will be free of defects in materials and workmanship that interfere with its proper operation as a sound masking, paging and music distribution control system. During that period, the warrantor will, at its option, either (a) repair the system, with new or refurbished parts, or (b) replace the system with a new or refurbished system of equal functionality at no charge. The decision to repair or replace will be made by the warrantor.

All software installed in the Qt system is warranted to substantially conform to its published specifications. In no event does the warrantor warrant that the software is error free or that the customer will be able to operate the software without problems or interruptions. The warrantor will, from time to time, make available software bug fixes. It is the responsibility of the purchaser to download and install these software modifications.

Except for the forgoing, all software and software upgrades are provided AS IS.

## The following terms apply to all

These warranty terms are extended only to the original purchaser of a new product. A purchase order or other proof of the original purchase date and purchaser is required for warranty service.

**Obtaining warranty repairs:** Please access and review online help resources for the product before requesting warranty service. If the product is still not functioning properly after making use of these resources, please contact Cambridge Sound Management for a return authorization number. All returns are to be prepaid. The warrantor will pay return surface freight within the continental United States on warranty repairs. All customs and freight charges in excess of surface freight within the United States will be born by the purchaser.

### Warranty Limits and Exclusions

This warranty ONLY COVERS failures due to defects in materials or workmanship, and DOES NOT COVER normal wear and tear or cosmetic damage. THIS WARRANTY DOES NOT COVER USE OF THE SYSTEM WITH ANY OTHER SPEAKER OR EMITTER MANUFACTURED BY ANY ENTITY, ORGANIZATION OR COMPANY OTHER THAN CAMBRIDGE SOUND MANAGEMENT, INC. OR USE OF THE SYSTEM FOR ANY PURPOSE OTHER THAN SOUND MASKING AND/OR PAGING AND/OR MUSIC DISTRIBUTION. THIS WARRANTY DOES NOT COVER THE USE OF ANYTHING OTHER THAN CAT-3 OR EQUIVALENT, 24 GAGE CABLING. The warranty ALSO DOES NOT COVER damages that occurred in shipment, failures that are caused by products not supplied by the warrantor (e.g., replacement power supplies) or failures that result from accidents, misuse, abuse, neglect, mishandling, misapplication, alteration of any sort, installation, use as a system driver during speaker installation, set-up adjustments, misadjustment of controls, improper maintenance, power line surge, lightning damage, power surges, modification, rental use, service by anyone other than the warrantor or damage that is attributable to acts of God.

THERE ARE NO EXPRESS OR IMPLIED WARRANTIES EXCEPT AS LISTED UNDER "WARRANTY COVERAGE." THE WARRANTOR IS NOT LIABLE FOR ANY INCIDENTAL OR CONSEQUENTIAL DAMAGES RESULTING FROM THE USE OF THE PRODUCT OR ARISING OUT OF ANY BREACH OF THIS WARRANTY. As an example, this specifically excludes damages for lost time, lost use of the system, cost of removal or reinstallation of the system or travel to and from the purchaser's location. ALL EXPRESS AND IMPLIED WARRANTIES ARE LIMITED TO THE PERIOD OF THE WARRANTY. This warranty provides specific legal rights, and there may be others that vary from state to state or in the country of compliant use. Therefore, certain additional exclusions may apply.

## Settings Record (Installer/Administrator)

If using software control, select the "Print Settings" link under the Administration page to print a complete list of system information. Place the printout in the job ticket holder near the control module. If using front panel control, fill in the details below. This information is critical to ease recovery from a hardware fault.

### Volumes:

Zone:	1	2	3	4	5	6
Masking:	_____	_____	_____	_____	_____	_____
Input A:	_____	_____	_____	_____	_____	_____
Input B:	_____	_____	_____	_____	_____	_____

### Networking and Security:

Mac Address: \_\_\_\_\_

Hostname: \_\_\_\_\_

Username: admin (default, can be changed)

Password: secret (default, can be changed)

### Installation / Service:

Company name: \_\_\_\_\_

Install date: \_\_\_\_\_

Phone: \_\_\_\_\_

### Zone Level Controls:

Zone:	1	2	3	4	5	6
Day Volume:	_____	_____	_____	_____	_____	_____
Night Volume:	_____	_____	_____	_____	_____	_____
Input A:	_____	_____	_____	_____	_____	_____
Input B:	_____	_____	_____	_____	_____	_____
Day Start Time, AM:	_____	_____	_____	_____	_____	_____
Night Start Time, PM:	_____	_____	_____	_____	_____	_____
Ramp Interval:	_____	_____	_____	_____	_____	_____
Saturday Schedule:	_____	_____	_____	_____	_____	_____
Sunday Schedule:	_____	_____	_____	_____	_____	_____









## Homerun Zone Destination Record

Zone 1            Run 1 \_\_\_\_\_            Run 2 \_\_\_\_\_

Zone 2            Run 1 \_\_\_\_\_            Run 2 \_\_\_\_\_

Zone 3            Run 1 \_\_\_\_\_            Run 2 \_\_\_\_\_

Zone 4            Run 1 \_\_\_\_\_            Run 2 \_\_\_\_\_

Zone 5            Run 1 \_\_\_\_\_            Run 2 \_\_\_\_\_

Zone 6            Run 1 \_\_\_\_\_            Run 2 \_\_\_\_\_

[cambridgesound.com](http://cambridgesound.com)

800.219.8199



[cambridgesound.com](http://cambridgesound.com) 800.219.8199

©2015 Cambridge Sound Management, Inc. All Right Reserved. "Qt Quiet Technology", "Qt", "Qt 100", "Qt 300", and "Qt 600" are trademarks of Cambridge Sound Management, Inc. All other trademarks and registered trademarks of their respective owners. All Specifications are subject to change. Visit [cambridgesound.com](http://cambridgesound.com) for latest specification information.