

SMAI™

AIR ROWER

OWNER'S MANUAL

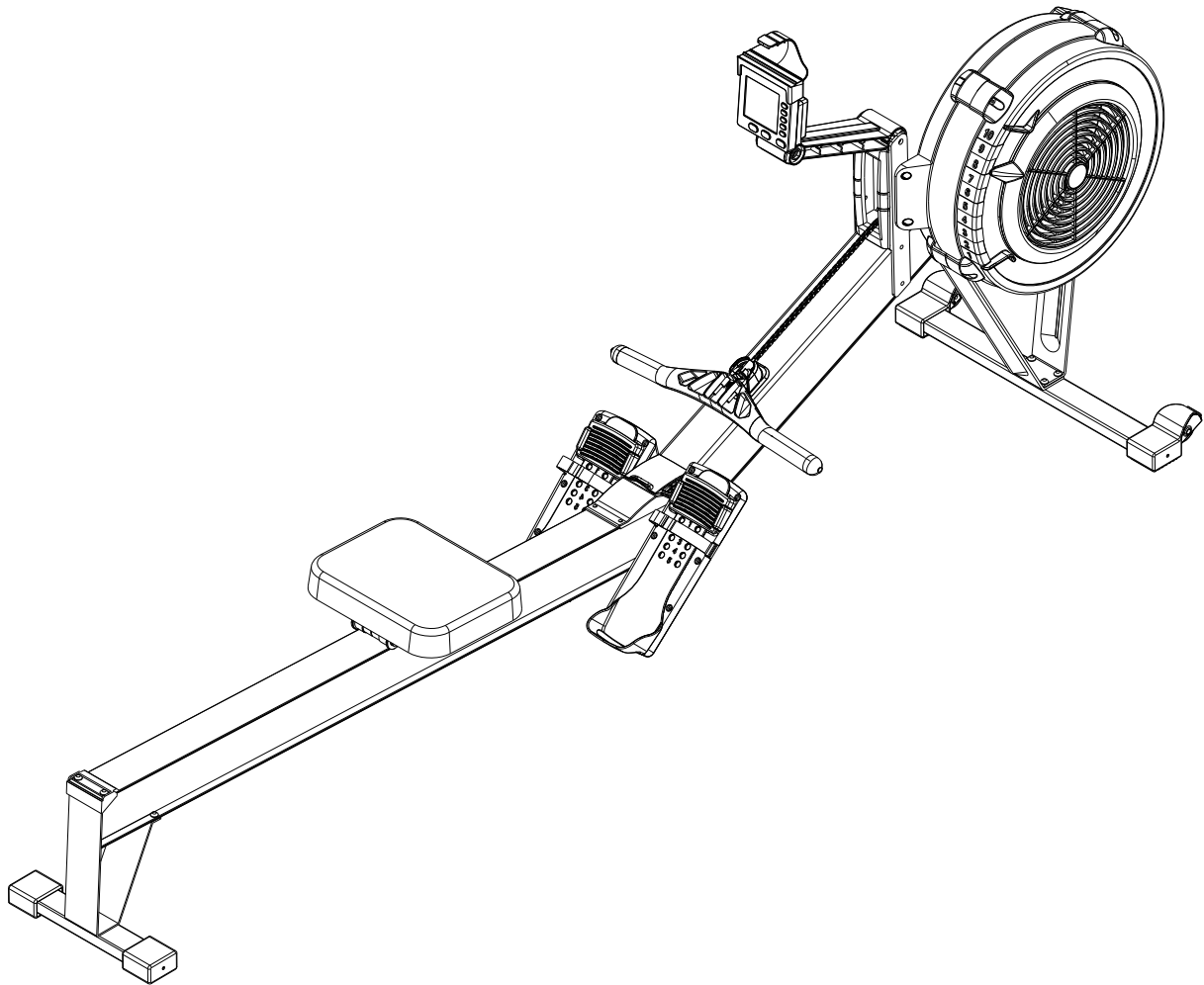

Table of Contents

Important Safety Information	PAGE 3-4
Machine Maintenance Guide	PAGE 5-12
Overview Of The Performance Monitor	PAGE 13-14
Safety Using Instruction	PAGE 15-18
Before You Start	PAGE 19
Accessory List	PAGE 20
Assembly Instruction	PAGE 21-29
Exploded View	PAGE 30
Part List	PAGE 31-34

Important Safety Information

Thank you for purchasing this AIR ROWER!

. To ensure your safety and health, please use this equipment correctly. It is important to read this entire manual before assembling and using the equipment. Safe and effective use can only be achieved if the equipment is assembled, maintained and used properly. It is your responsibility to ensure that all users of the equipment are informed of all warnings and precautions.

1. Before starting any exercise program, you should consult your physician to determine if you have any medical or physical conditions that could put your health and safety at risk or prevent you from using the equipment properly. Your physician's advice is essential if you are taking medication that affects your heart rate, blood pressure or cholesterol level.
2. Be aware of your body's signals. Incorrect or excessive exercise can damage your health. Stop exercising if you experience any of the following symptoms: pain, tightness in your chest, irregular heartbeat, shortness of breath, lightheadedness, dizziness or feelings of nausea. If you do experience any of these conditions, you should consult your physician before continuing with your exercise program.
3. Keep children and pets away from the equipment. The equipment is designed for adult use only.
4. Use the equipment on a solid, flat level surface with a protective cover for your floor or carpet. To ensure safety, the equipment should have at least 2 feet (60 CM) of free space all around it.
5. Ensure that all nuts and bolts are securely tightened before using the equipment. The safety of the equipment can only be maintained if it is regularly examined for damage and/or wear and tear.
6. Always use the equipment as indicated. If you find any defective components while assembling or checking the equipment, or if you hear any unusual noises coming from the equipment during exercise, discontinue use of the equipment immediately and do not use until the problem has been rectified.
7. Wear suitable clothing while using the equipment. Avoid wearing loose clothing that may become entangled in the equipment.
8. Do not place fingers or objects into the moving parts of the equipment.
9. The maximum weight capacity of this unit is **320 pounds (145 KGS)**.
10. The equipment is not suitable for therapeutic use.
11. To avoid bodily injury and/or damage to the product or property, proper lifting and moving are required.

12. Your product is intended for use in cool and dry conditions. You should avoid storage in extreme cold, hot or damp areas as this may lead to corrosion and other related problems.

13. This equipment is designed for indoor only.



WARNING: BEFORE BEGINNING ANY EXERCISE PROGRAM CONSULT YOUR PHYSICIAN. THIS IS ESPECIALLY IMPORTANT FOR INDIVIDUALS OVER THE AGE OF 35 OR PERSONS WITH PRE-EXISTING HEALTH PROBLEMS. READ ALL INSTRUCTIONS BEFORE USING ANY FITNESS EQUIPMENT. WE ASSUME NO RESPONSIBILITY FOR PEROSNAL INJURY OR PROPERTY DAMAGE SUSTAINS BY OR THROUGH THE USE OF THIS PRODUCT.

Machine Maintenance Guide

(1) Flex Foot (G36) adjustment

The pedal strap is adjustable and can be personalized to fit the user's foot size per the below steps:

Step 1: Push and hold the Flex Foot Adjuster (G30) on two sides, then adjust the Flex Foot (G36) forward or backward to your desired foot size.

Step 2: With your feet tightly secured by the FOOT STRAP W/BUCKLE (G41).

NOTE:

Pls make sure the protruding pricks inside the Flex Foot Adjuster (G30) has been stuck on the circular pits on Flex Foot (G36) base on your desired foot size position tightly.

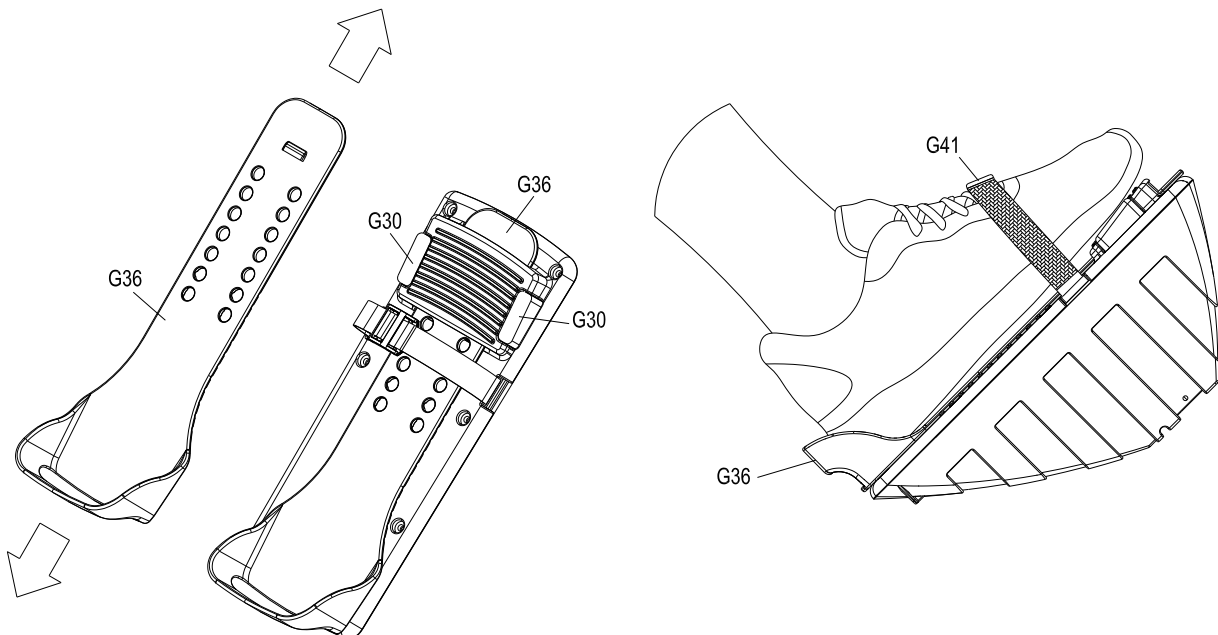

Machine Maintenance Guide

(2) Bungee Cord (G40) Replacement

-Pls follow the instructions which are shown from PAGE 6 ~ PAGE10

Step 1: Pls turn upside down the machine and remove Screws (B17X6) from Lower Decoration Plate (A04).

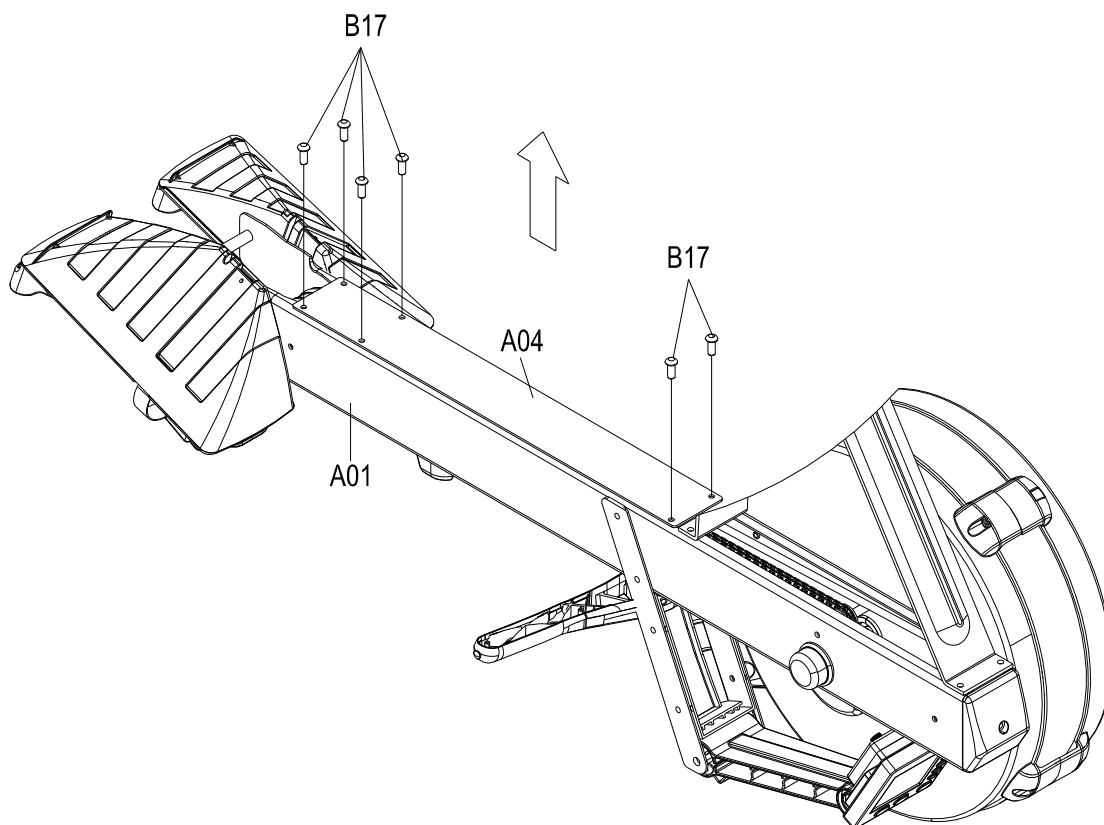

Machine Maintenance Guide

(2) Bungee Cord (G40) Replacement

Step 2: Release Bungee Cord (G40) from Cord Adjustment Hook Plates (A14).

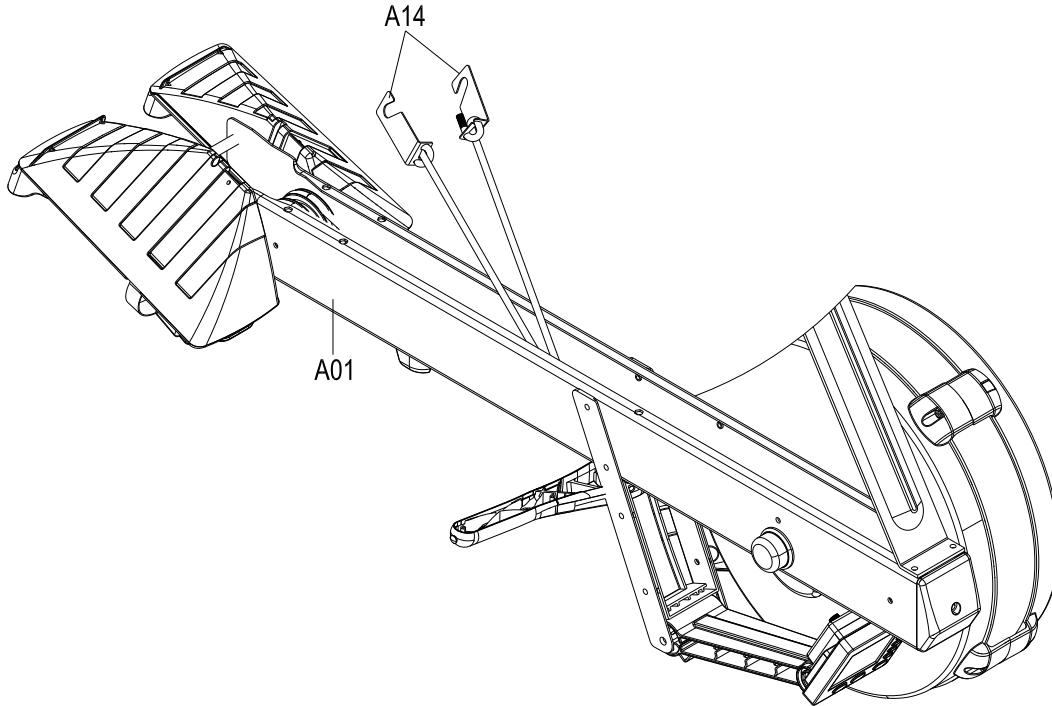

Step 3: Remove Cord Adjustment Hook Plates (A14) to be separated from the Bungee Cord (G40).

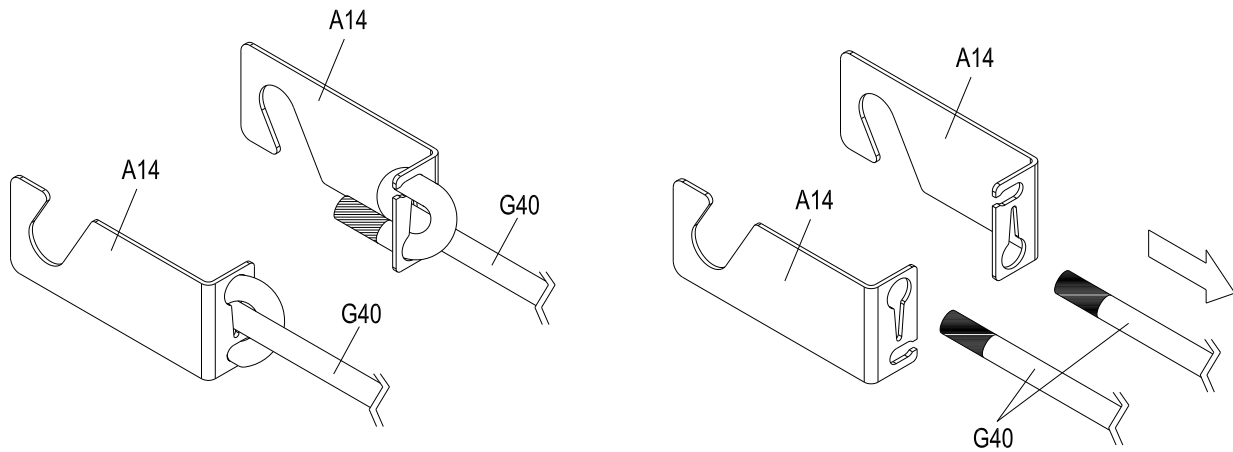

Machine Maintenance Guide

(2) Bungee Cord (G40) Replacement

Step 4: Pull out Bungee Cord (G40) from Cord Pulley Mounting Plate (A13).

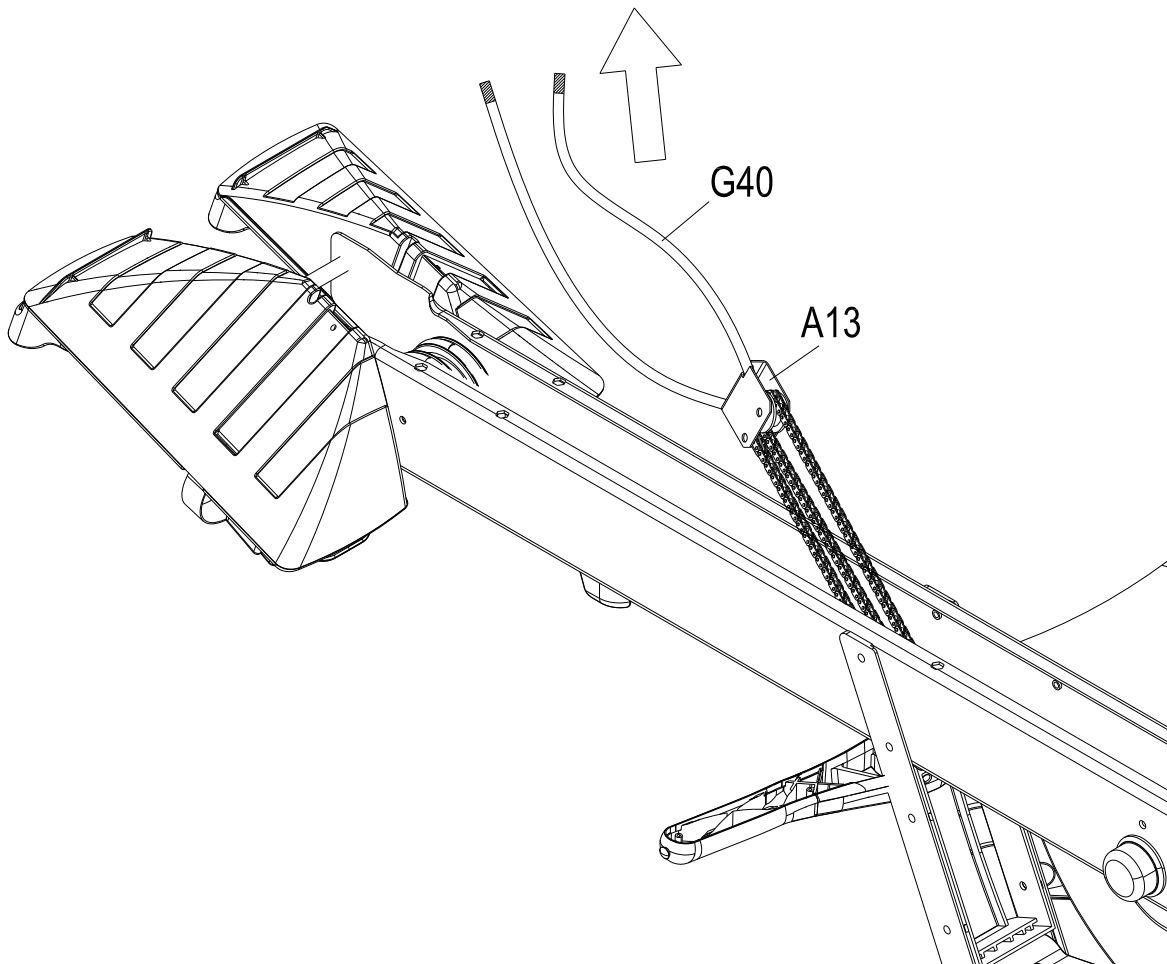

Machine Maintenance Guide

(2) Bungee Cord (G40) Replacement

Step 5: Push equal amounts of cord (G40) through both Cord Adjustment Hook Plates (A14) as shown on diagrams (A) ~ (F).

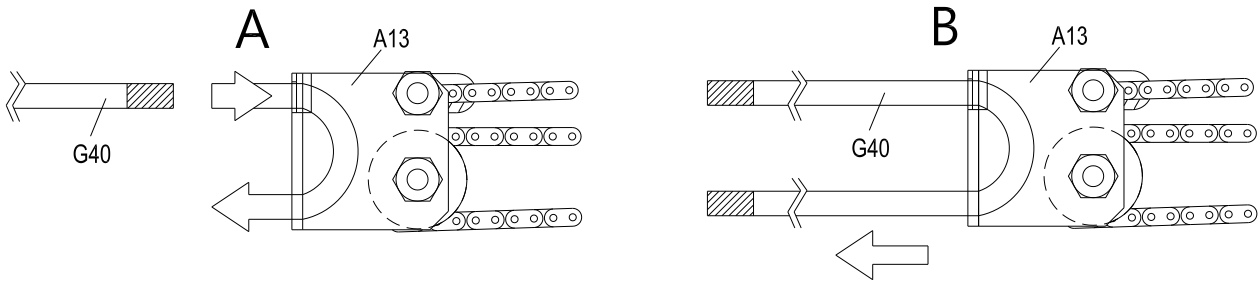

Note: Length on two sides of Bungee Cord should be equal (as shown below)

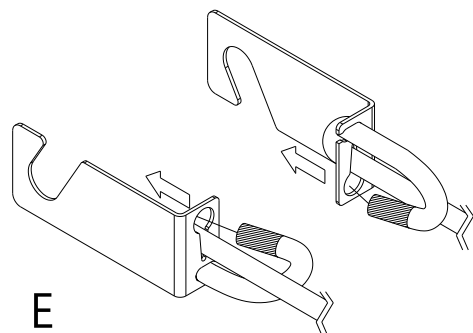
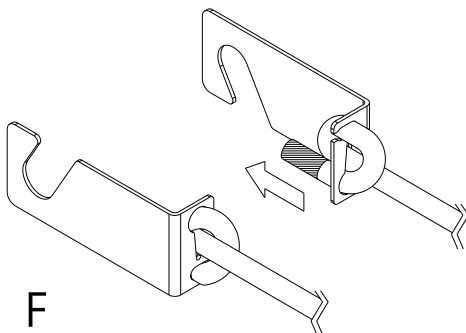
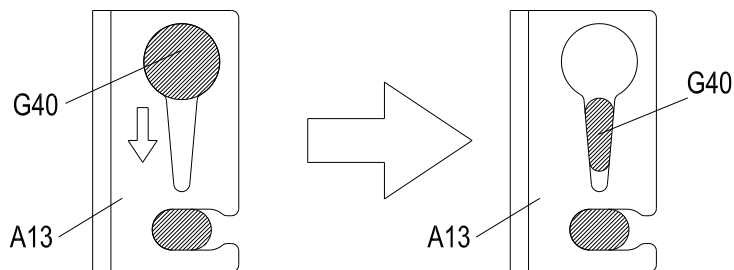
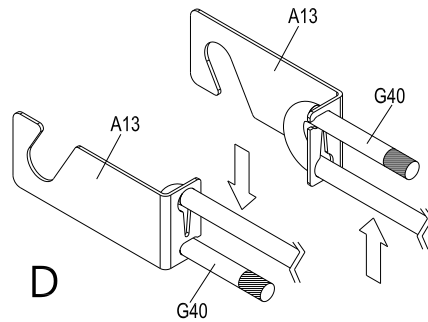
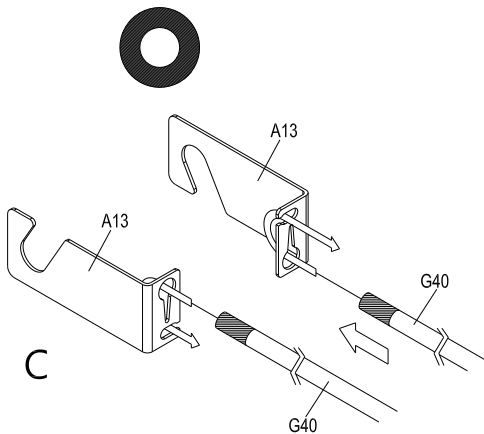
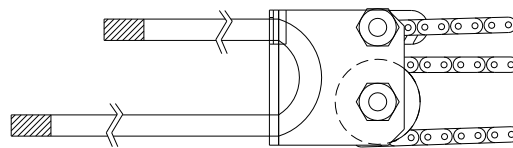
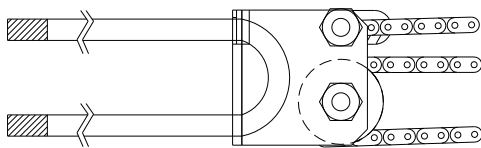

Machine Maintenance Guide

(2) Bungee Cord (G40) Replacement

Step 6: Wrap the replaced Bungee Cord (G40) around the Cord Pulley (G29).

Step 7: Re-hook both Cord Adjustment Hook Plates (A14) to the Cord Pulley Axle (E21) on two sides.

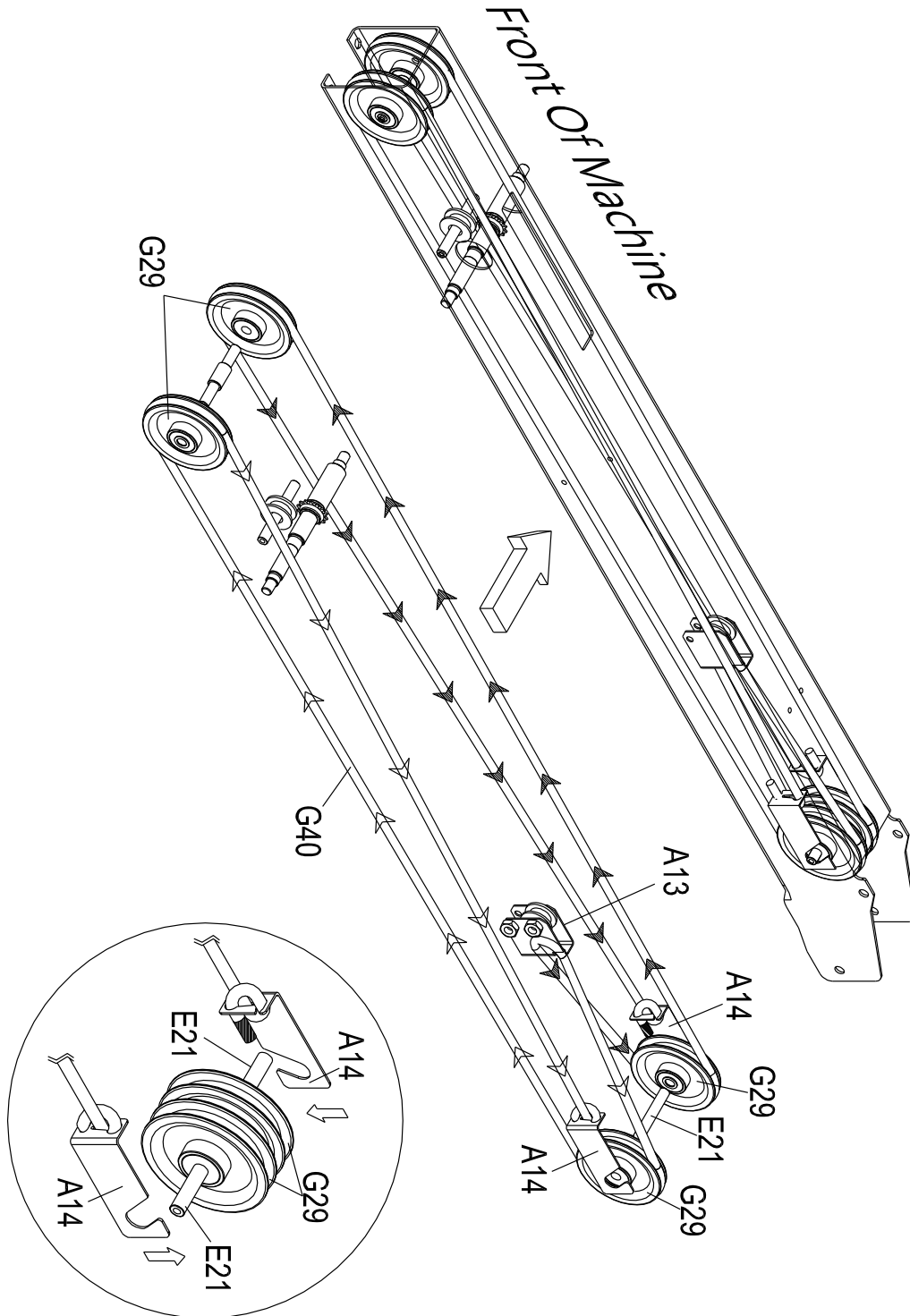

Machine Maintenance Guide

(3) Chain Routing checking

The correct Chain Routing should be as below image, (the Bungee Cords (G40) & Flywheel are omitted for clarity.) (Front end is shown upside down).

Note 1: The Chain (E24) has to be installed to the Axle Sprocket(E10) correctly and smoothly as the diagram.

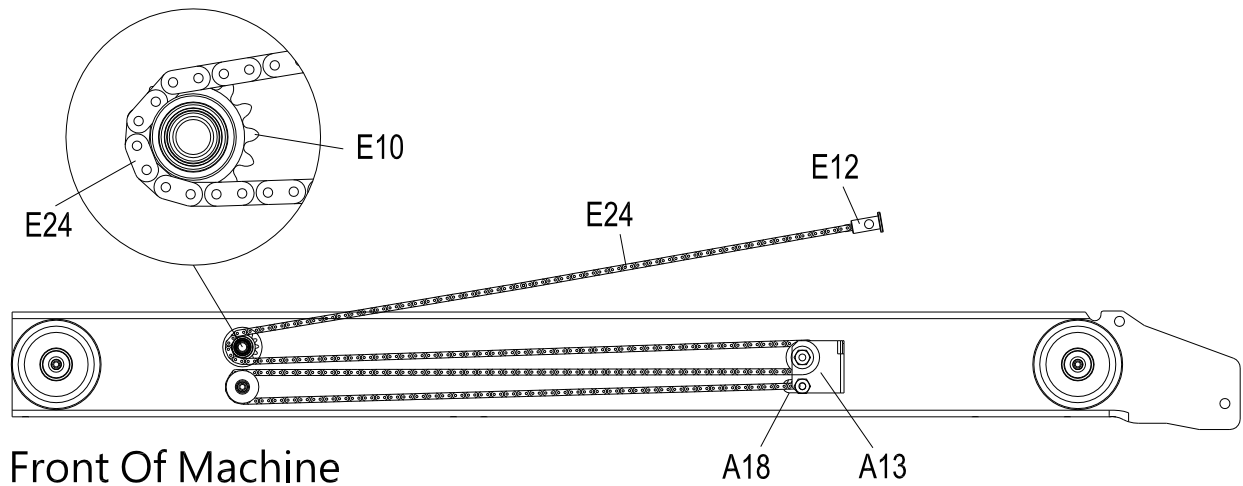

Note 2: Pls recheck the Chain Routing before re-attaching the Lower Decoration Plate (A04) back to the Main Frame (A01)

Next re-attach the Lower Decoration Plate (A04) to the Main Frame by using the Screws (B17 X 6) as shown.

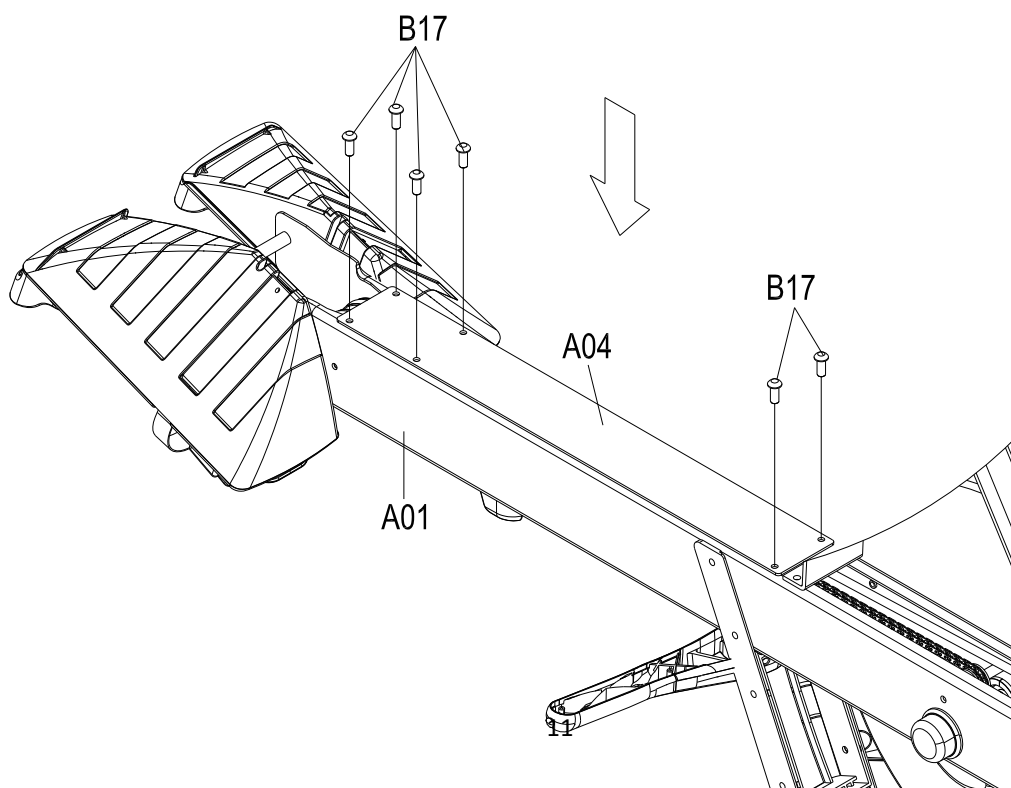

Machine Maintenance Guide

(4) WORKOUT INTENSITY ADJUSTMENT

- This Air Rower uses wind resistance, which is generated by the spinning flywheel. The harder you pull, the more resistance you will feel. The faster you get the wheel spinning, the more resistance there will be.
- You can row as hard or as easy as you wish. This Air Rower will not force you to row at any set intensity level. It is up to you. As you put more effort into your rowing, you will go faster, produce more watts, and burn more calories. All of these outputs will be measured and displayed by the Monitor.

DAMPER SETTINGS ON THE FLYWHEEL

- The damper setting is like bicycle gearing. It affects the feel of the rowing but does not directly affect the resistance. With a little experimentation, you will find the damper setting that gives you the best workout and results. We recommend a damper setting of 3-5 for the best aerobic workout. This is the setting that feels most like a sleek, fast boat on the water. Higher settings feel more like a bigger, slower boat. Rowing with the damper setting too high can be detrimental to your training program because it may refine your output and increase your risk of injury.

Adjust Down for Faster

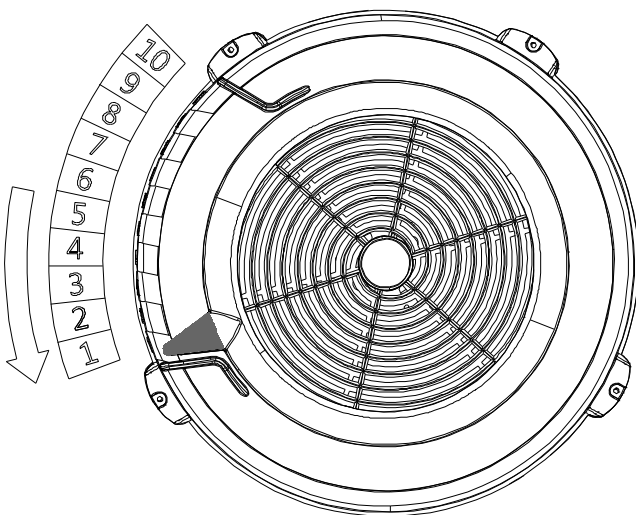

Adjust Up for Slower

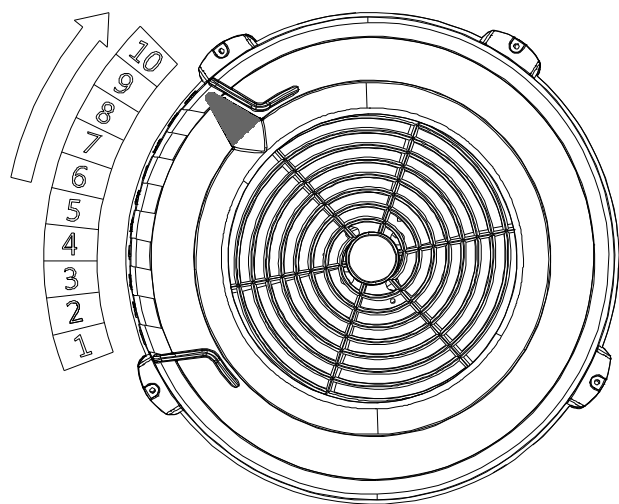

OVERVIEW OF THE PERFORMANCE MONITOR (V2)

For Dynamic Indoor Air Rower, and the Air Skier.

Getting Started:

General Operation

- The V2 will automatically displays your workout data as you start your workout on the machine , or press the MENU button/Any buttons to power up the V2 monitor .
- Press MENU button to go back to the previous display .
- Use the MENU button to access all features.

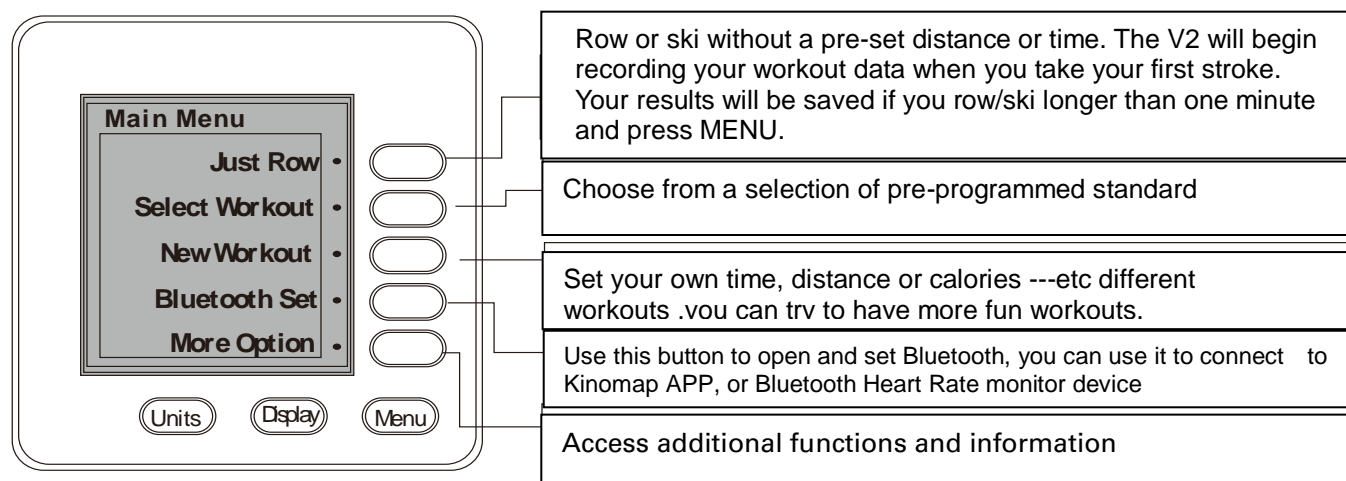

Bluetooth Device Pairing & Select.

BLE Heart Monitor Connection: use Bluetooth Set at Menu, Once enter Bluetooth Set display will

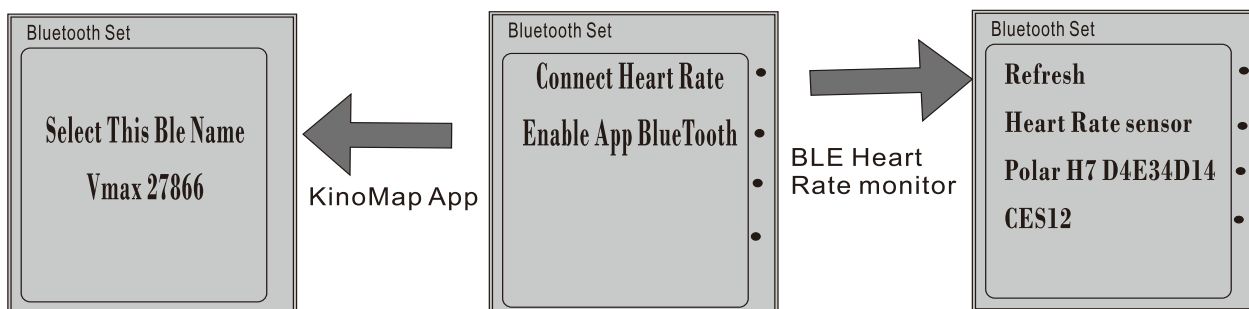

shows Connect Heart Rate and Enable App Bluetooth, select Connect Heart Rate, V2 will find all the BLE heart rate monitor and showing on the display, please select device you have. Then it will connect each together, if you can not find your device, please use Refresh to re-find all BLE device.

KinoMap APP connection: Turn your Bluetooth of smart phone, the use system setting to finding Vmax XXXXX(BLE SERIAL NUMBER), Once VmaxXXXXX (BLE SERIAL NUMBER) Is found on smart phone, please connect it, then you can work it on your phone.

Memory Workout: from Kinomap all of your workout can be saved in your workout database. You can review it any time.

Firmware : Firmware is the internal software that runs your Performance Monitor(V2). Your V2 comes pre-installed with the latest firmware, however, new and improved versions are offered regularly. The free V2 software makes posted regularly. The free V2 Utility Software makes it easy to update your software with the latest firmware version at any time. When V2 detect flash drive (USB) with newest version software, it will automatic update software,

Caution: don't unplug flash drive (USB)until update finished.

V2 Menu Map

The diagram shows a digital display with the following information:

- Top row: **:17 23** s/m (Strokes per minute)
- Second row: **2:23** (Total elapsed time)
- Third row: **45_m 120** (Total meters rowed or skied)
- Fourth row: **2: 33.8** avg /500m (Average pace)
- Fifth row: **43** split meters (Split meters)
- Sixth row: **5708** projects /m 30:00 (Projected meters in 30 minutes)

Control buttons below the display:

- Units**: Push at any time to change units between Meters(m), Pace (time/500m), Watts and Calories (Cal).
- Display**: Push to change display between All Data, Force Curve, Faceboat /Pace Skier, Bar Chart, and Large Print.
- MENU**: Push to power up the PM, display the previous menu or save workout results.

Additional metrics and functions:

- Heart rate** (Optional. Requires additional chest belt.)
- Projected meters in 30 minutes if the current Split meters.** The number average pace is maintained.

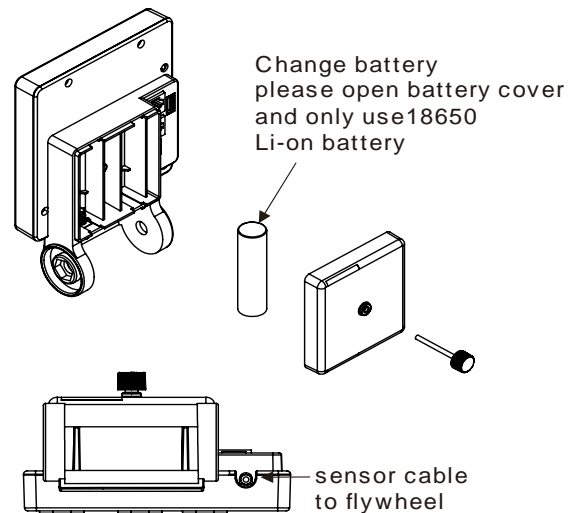
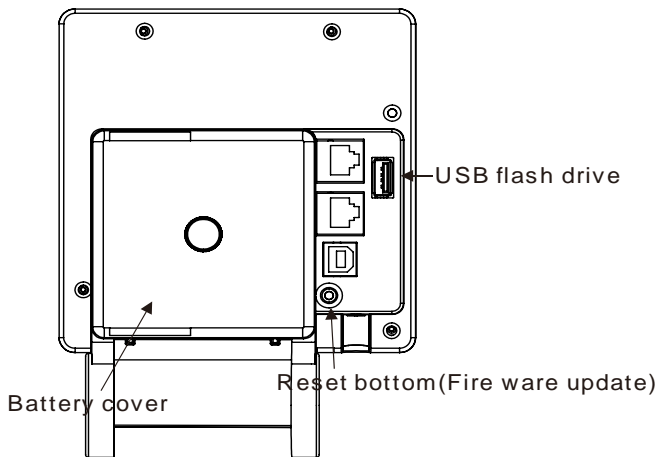

Safety Using Instruction

Stretching should be included in both your warm up and cool down, and should be performed after 3-5 minutes of low intensity aerobic activity or callisthenic type exercise. Movements should be performed slowly and smoothly, with no bouncing or jerking. Move into the stretch until slight tension, not pain, is felt in the muscle and hold for 20-30 seconds. Breathing should be slow, rhythmical and under control, making sure never to hold your breath.

1

Head rolls

Rotate your head to the right for one count, feeling the stretch up the left side of your neck. Next rotate your head back for one count, stretching your chin to the ceiling and letting your mouth open. Rotate your head to the left for one count, and finally, drop your head to your chest for one count.



2

Toe touches

Slowly bend forward from your waist, letting your back and shoulder relax as you stretch toward your toes. Reach down as far as you can and hold for 15 seconds.



3

Shoulder lifts

Lift your right shoulder up toward your ear for one count. Then lift your left shoulder up for one count as you lower your right shoulder.

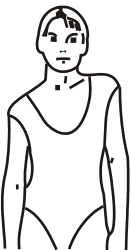

4

Quadriceps stretch

With one hand against a wall for balance, reach behind you and pull your right foot up. Bring your heel as close to your buttocks as possible. Hold for 15 counts and repeat with left foot up.



5

Side stretches

Open your arms to the side and continue lifting them until they are over your head. Reach your right arm as far upward toward the ceiling as you can for one count. Feel the stretch up your right side. Repeat this action with your left arm.



6

Hamstring stretches

Sit with your right leg straight in front of you. Straighten your leg out while trying to hold on to your outstretched leg with your hand. Starting up with your back straight. Slowly exhale and try to bring your chest to the knee of your outstretched leg. Hold, then repeat on the other side for 15 seconds.



7**Inner thigh stretch**

Sit with the soles of your feet together with your knees pointing outward. Pull your feet as close into your groin as possible. Gently push your knees toward the floor. Hold for 15 counts.

8**calf/ Achilles stretch**

Lean against a wall with your left leg in front of the right and your arms forward. Keep your right leg straight and the left foot on the floor; then bend the left leg and lean forward by moving your hips toward the wall. Hold, then repeat on the other side for 15 seconds.

Safety Using Instruction

PROPER ROWING TECHNIQUE INSTRUCTION

The rowing stroke can be divided into two parts: **the drive and the recovery**. The drive is in the work portion of the strokes; the recovery is the rest portion that prepares you for the next drive. The body movements of the recovery are essentially the reverse of the drive. Blend these movements into a smooth continuum to create the rowing stroke.

The followings are the proper rowing technique demonstration

(1) The Catch

- Arms are straight; head is neutral; shoulders are level and not hunched.
- Upper body is leaning forward from the hips with the shoulders in front of the hips.
- Shins are vertical, or as close to vertical as comfortable for you. Shins should not move beyond perpendicular.
- Heels may lift as needed.

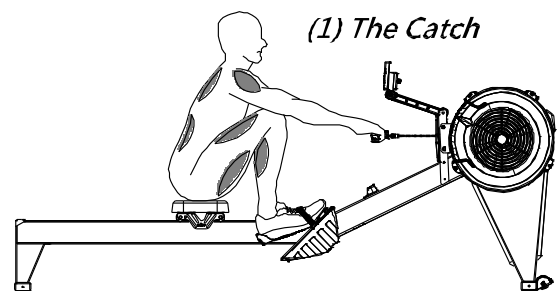

(2) The Drive

- Start the drive by pressing with your legs, and then swing the back through the vertical position before finally adding the arm pull.
- Hands move in a straight line to and from the flywheel.
- Shoulders remain low and relaxed.

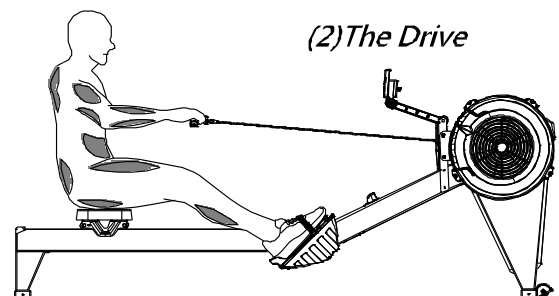

(3) The Finish

- Upper body is leaning back slightly, using good support from the core muscles.
- Legs are extended and handle is held lightly below your ribs.
- Shoulders should be low with wrists an

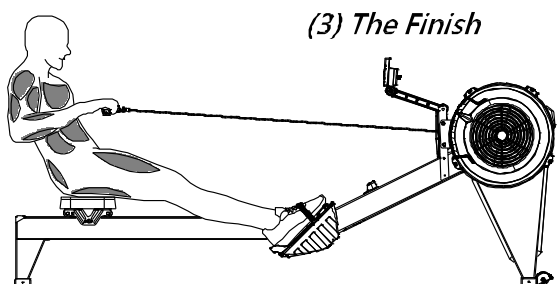

(4) The Recovery

- Extend your arms until they straighten before leaning from the hips towards the flywheel.
- Once your hands have cleared your knees, allow your knees to bend and gradually slide the seat forward on the monorail.
- For your next stroke, return to the catch position with shoulders relaxed and shins vertical.

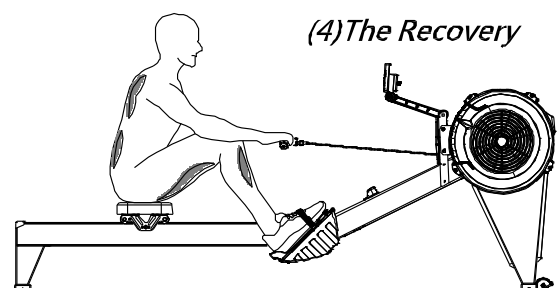

Safety Using Instruction

IMPORTANT USE AND SAFETY NOTE

Use of this machine with a worn or weakened part, such as the chain, sprockets, chain/swivel connector, handle U-bolt or cord, may result in injury to the user. When in doubt about the condition of any parts, we strongly advise that it should be repaired or replaced immediately.

Pls use the machine and follow below notes correctly to avoid any injury.

Note 1: Keep clothing free of seat rollers.

Diagram 1

(See Diagram1)

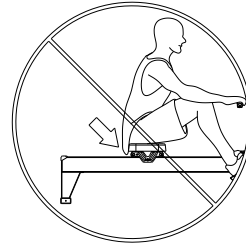

Note 2: Keep children, pets and fingers away from seat rollers. Seat rollers can cause injury.

Diagram 2

(See Diagram2)

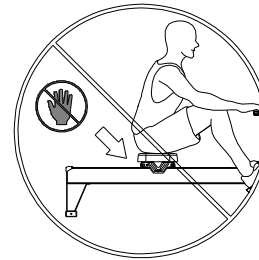

Note 3:

*Place handle against chain guide or in handle hooks before letting go.

Diagram 3

*Do not let handle fly into chain guide.

(See Diagram3)

Note 4:

*Pull straight back with both hands. Do not row with one hand only. Abuse of the chain can result in injury.

* Handle should be used horizontally, do not flip.

(See Diagram4)

*If there are abnormal sounds or the parts are loose, please stop using immediately and contact the technician.

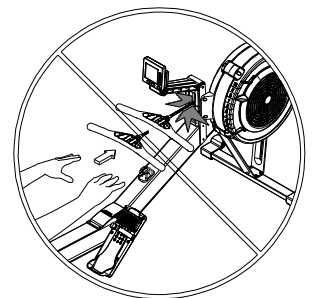
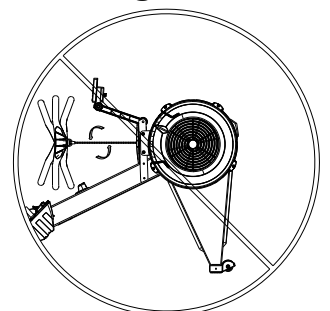

Diagram 4



Before You Start

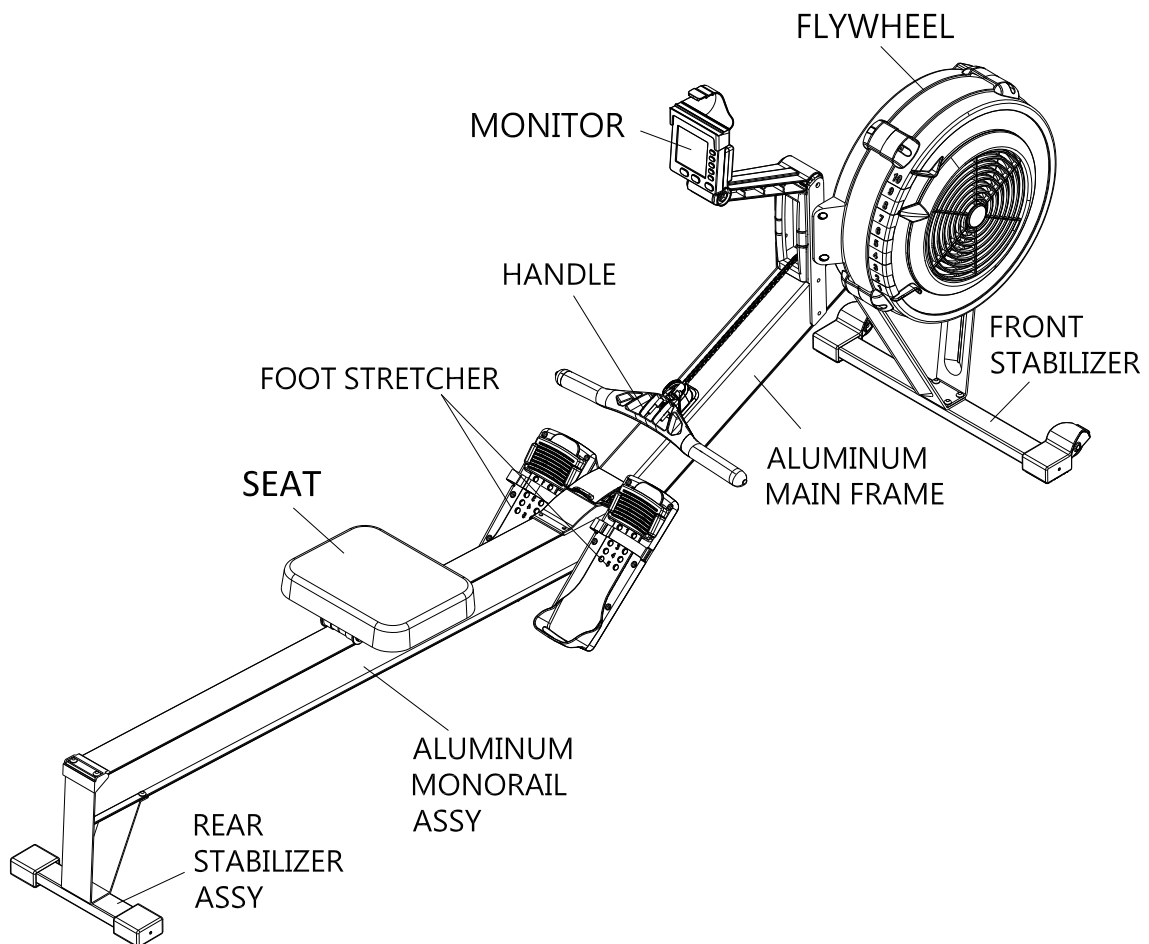

Thank you for choosing this Air Rower. We take great pride in producing this quality product and hope it will provide many hours of quality exercise to make you feel better, look better, and enjoy life to its fullest. It's a proven fact that a regular exercise program can improve your physical and mental health. Too often, our busy lifestyles limit our time and opportunity to exercise. The Indoor Rower provides a convenient and simple method to begin your assault on getting your body in shape and achieving a happier and healthier lifestyle.

****Before you start to assemble the machine, please review the following drawing to familiarize yourself with the listed parts. Also, pls be sure to read the below instructions first and follow each assembly steps.**

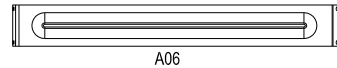
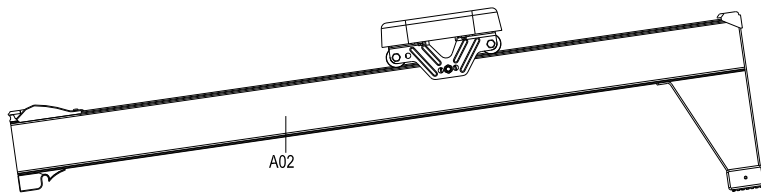
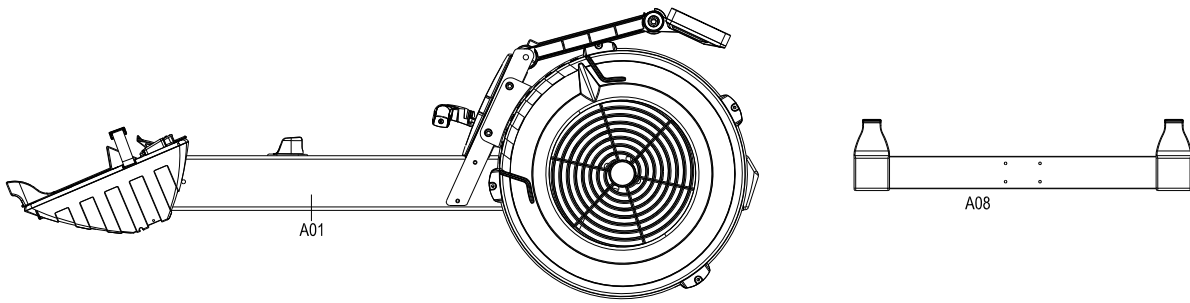

Accessory List



 B17*4  TOOL

 B19*4

1	ALUMINUM MAIN FRAME ASSY (#A01) X 1PC
2	ALUMINUM MONORAIL ASSY(A02) x1 SET
3	FRONT FOOT LEG(LONG)(ALUMINUM)(A06) X1PC
4	FRONT FOOT LEG(SHORT)(ALUMINUM)(A07) X1PC
5	FRONT STABILIZER(A08) X1PC
6	M6*P1.0*15L HEX SCREW(LICOTTED)(STAINLESS)(B17) X4PCS
7	M6*P1.0*20L HEX SCREW(LICOTTED)(STAINLESS)(B19) X4PCS
8	TOOL (WRENCH) X1 PCS

Assembly Instruction

FIGURE 1: HOW TO ASSEMBLE THE FRONT STABILIZER (A08)

Sept 1:

Secure Front Foot Leg (Long) (A06) & Front Foot Leg (Short) (A07) to the front stabilizer (A08) by using four screws (B19).

Secure above Foot legs (Long & Short) (A06 & A07) with Front Stabilizer Assy (A08) to the front of Main Frame (A01) by using four screws (B17).

FIGURE 1:

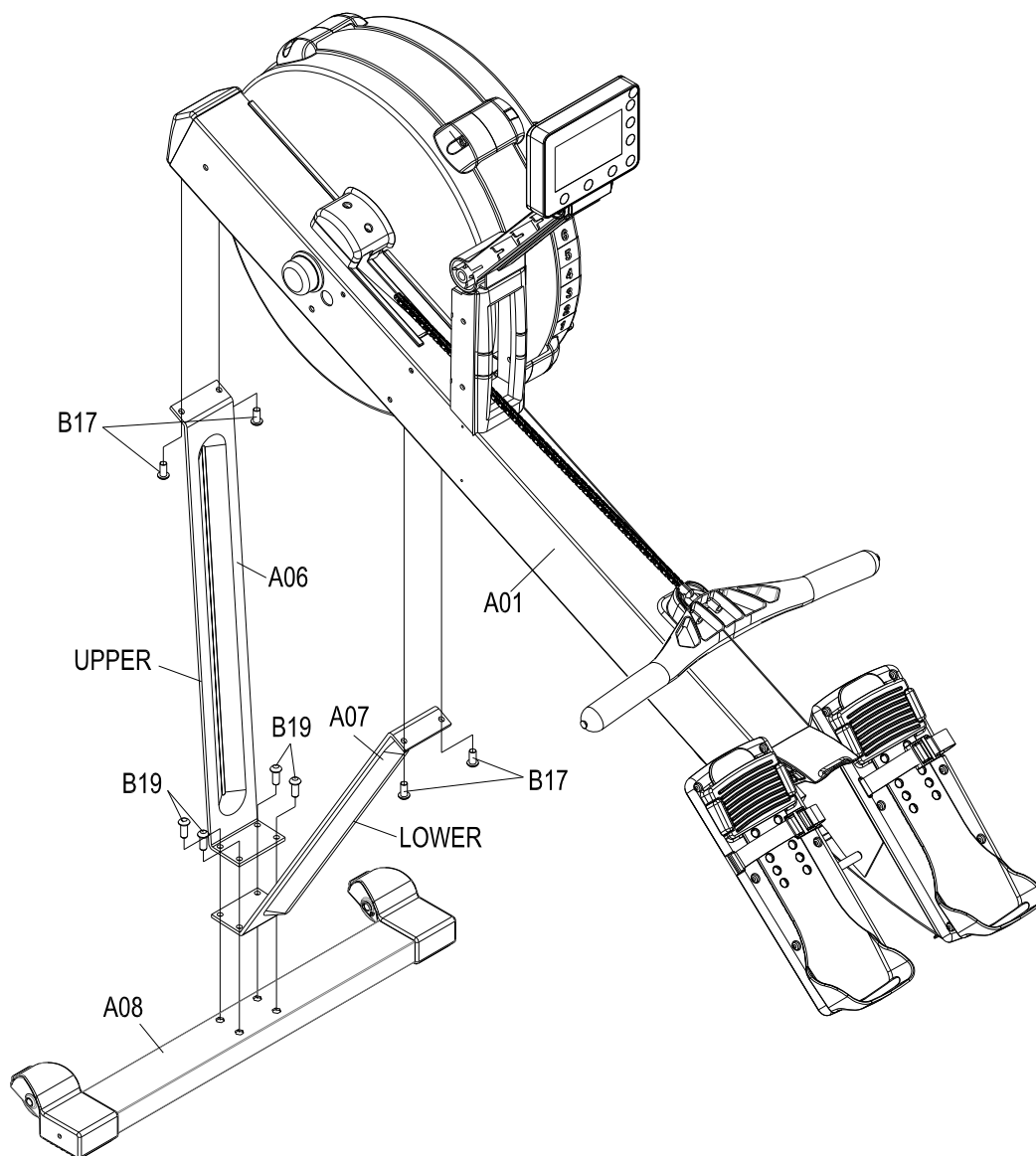

Assembly Instruction

FIGURE 2-1 : HOW TO ASSEMBLE THE MONORAIL ASSY(A02) TO THE MAIN FRAME (A01)

Lift up Foot strap (G41) located at the front of MAIN FRAME(A01), then attach Monorail Assy (A02) to the front of Main Frame (A01).

FIGURE 2-1 :

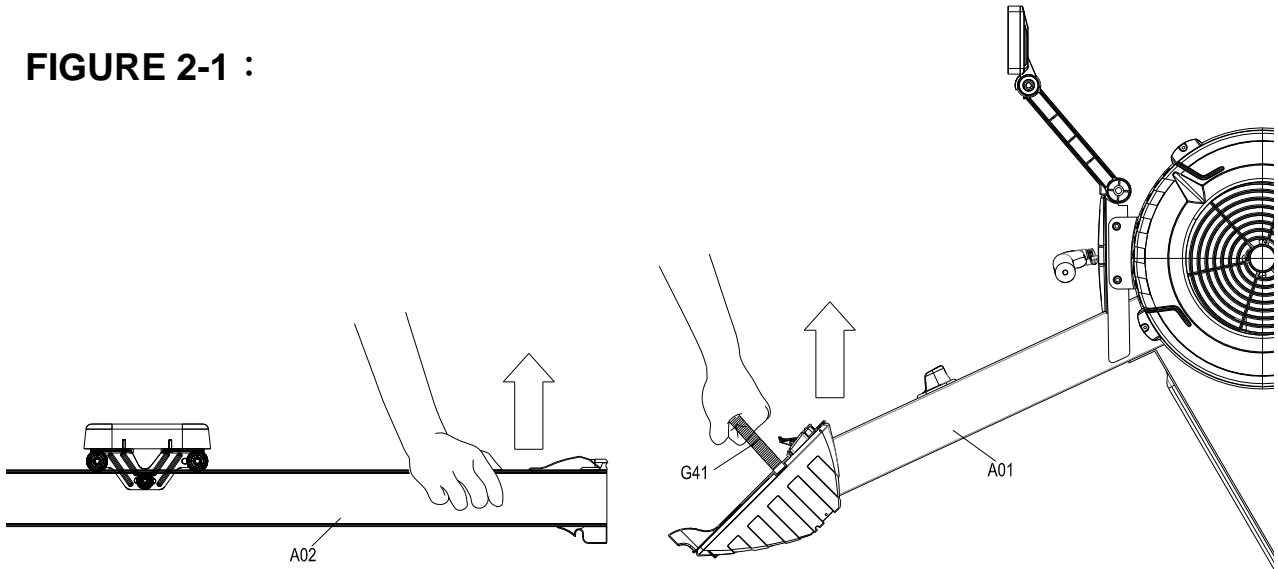
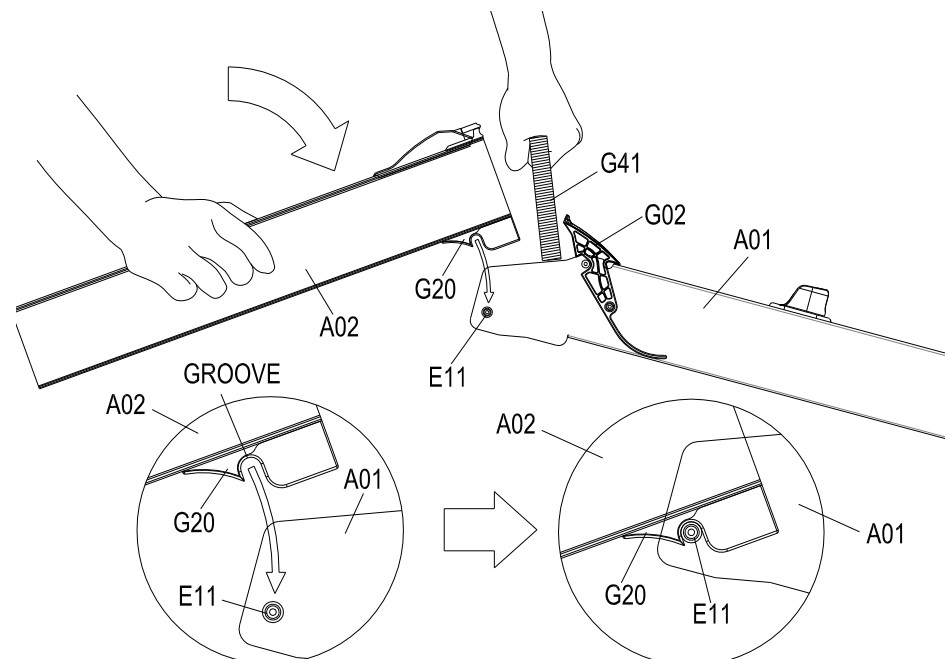

FIGURE 2-2 : HOW TO ASSEMBLE THE MONORAIL ASSY(A02) TO THE MAIN FRAME (A01)

Insert the circular groove located on the Monorail Front Cover (lower) (G20) to be hooked into the Hanger Shaft (E11) on lower part of front Main Frame (A01).

FIGURE 2-2 :



Assembly Instruction

FIGURE 2-3 : HOW TO ASSEMBLE THE MONORAIL ASSY(A02) TO THE MAIN FRAME (A01)

Slowly lay down the connecting Monorail Assy (A02) & Main Fame (A01) till the notch on the Upper Die Cast Hanger (E22) to be stuck into the Hanger Shaft (E11) which located on the upper part of front Main Frame (A01) (below G02 cap).

FIGURE 2-3

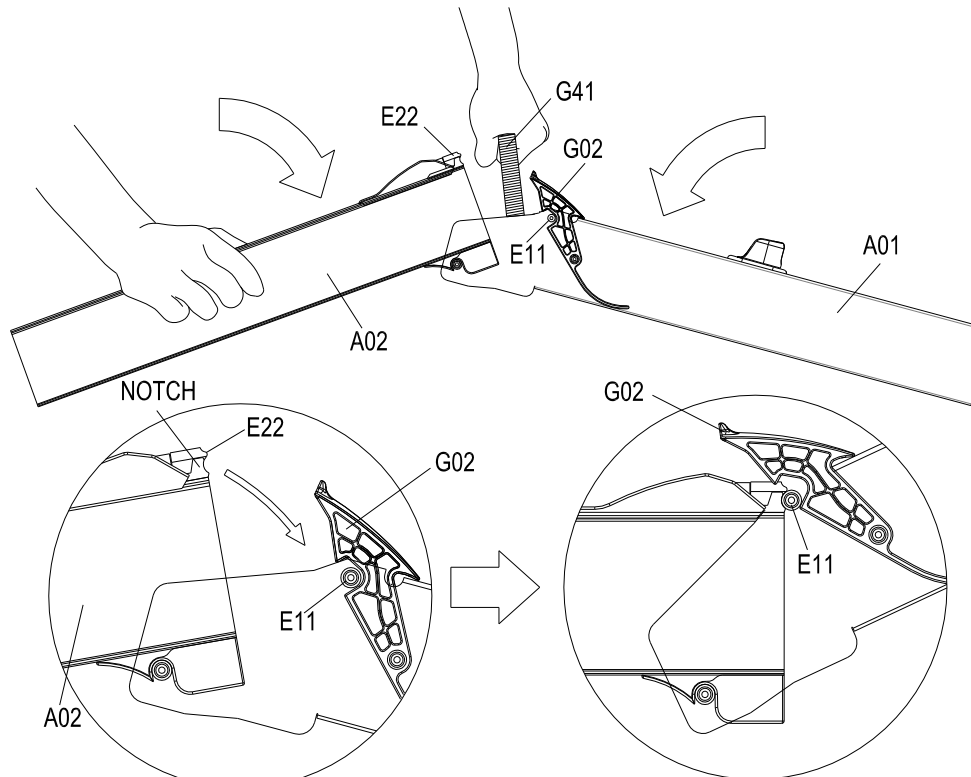
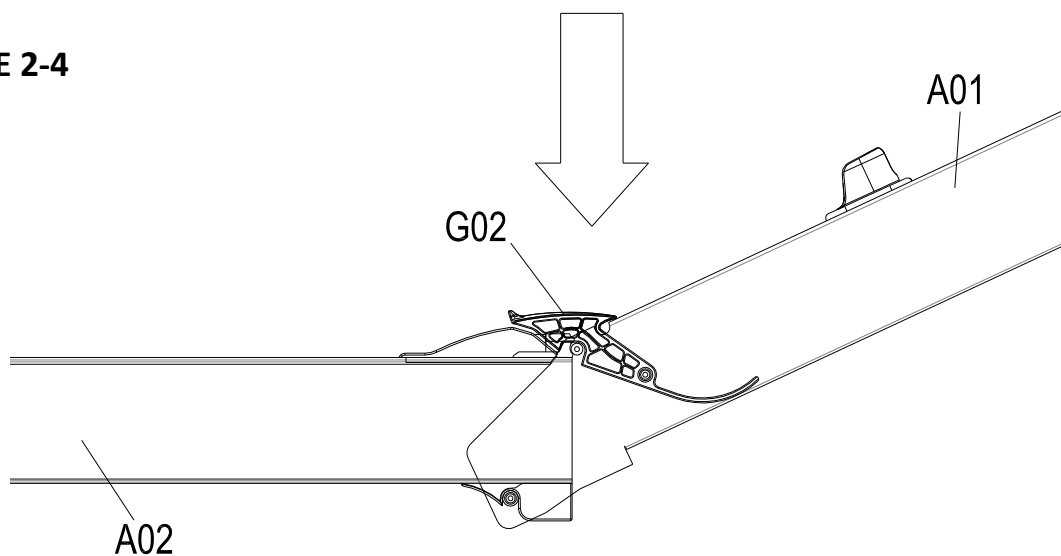

FIGURE 2-4 : HOW TO ASSEMBLE THE MONORAIL ASSY (A02) TO THE MAIN FRAME (A01)

Finally, slightly push Main Frame Connection Cap (G02) above the connecting Monorail Assy (A02) & Main Fame (A01).

FIGURE 2-4



Assembly Instruction

FIGURE 2-5 : HOW TO ASSEMBLE THE MONORAIL ASSY (A02) TO THE MAIN FRAME (A01)

FIGURE 2-5

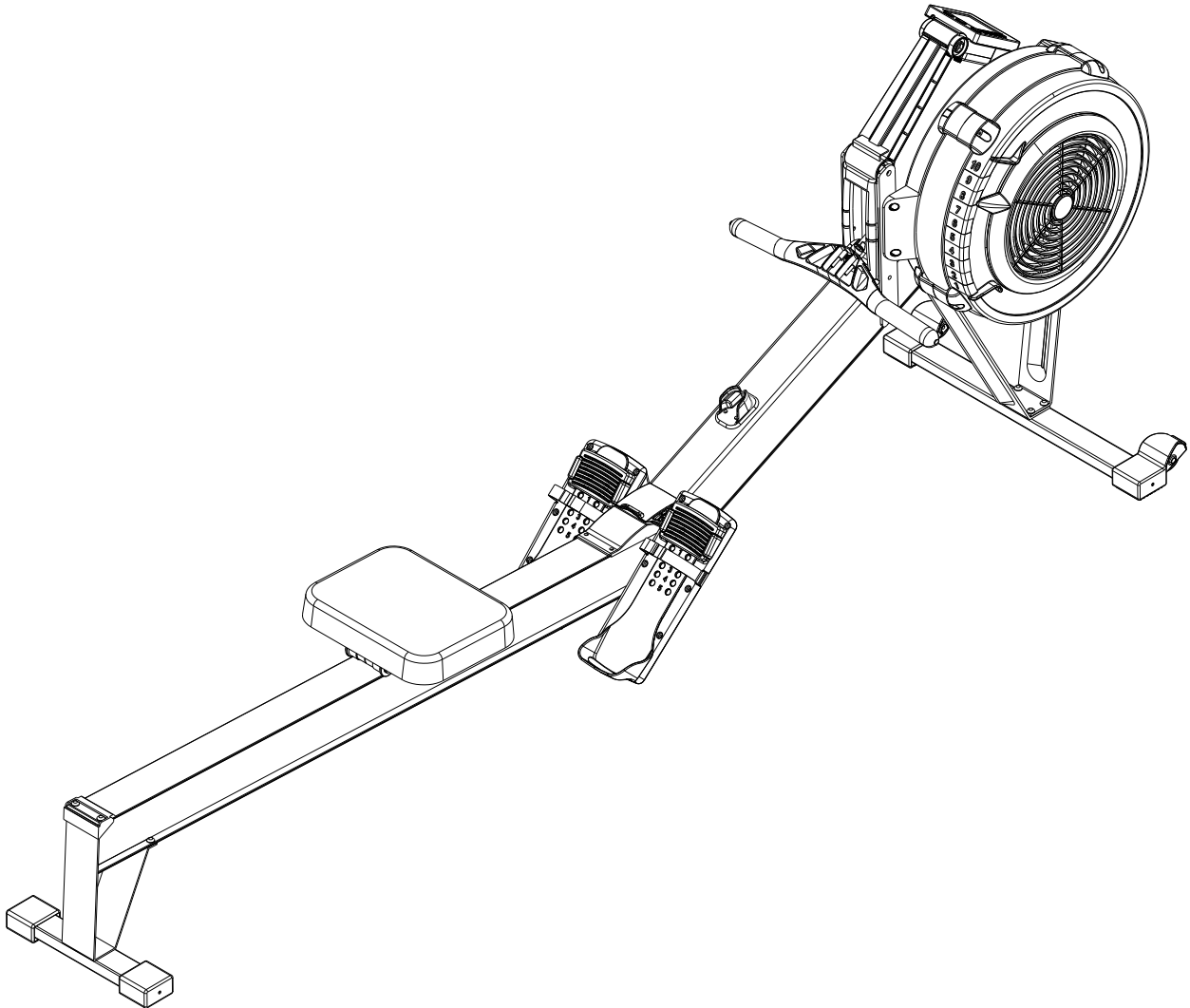

You have completed the main assembly of your **MONORAIL ASSY(A02)** to the **MAIN FRAME (A01)**.

Assembly Instruction

FIGURE 3 : HOW TO ADJUST THE POSITION FOR MONITOR & INSTALL THE HANDLE

Step 1:

The Monitor Arm (G44) and the Monitor (H02) are adjustable.

Adjust the Monitor Arm (G44) to your desired position by moving it up and down.

Attach the Monitor Top Shroud (G45) above the Monitor (H02).

Step 2:

Locate the Handle U-Bolt (B03) into the Handle Hook (G04).

FIGURE 3 :

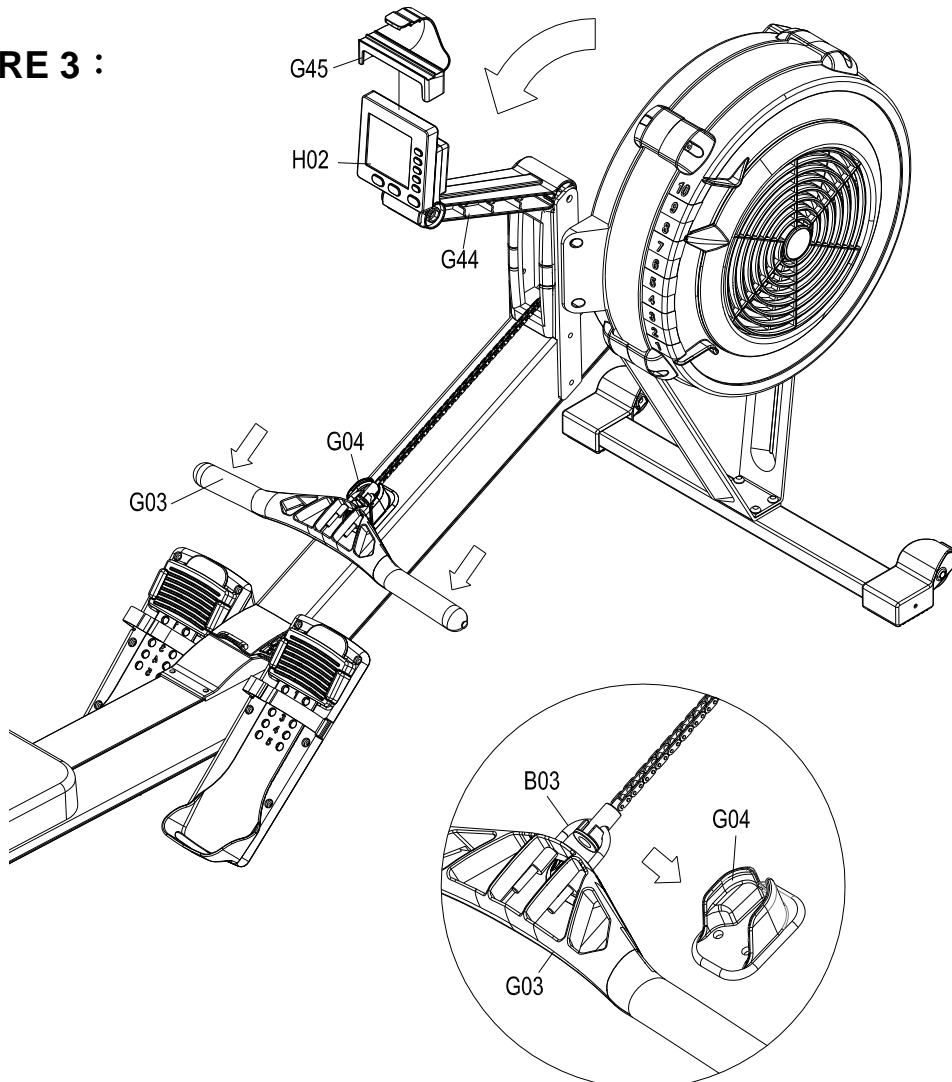

Assembly Instruction

FIGURE 4 :

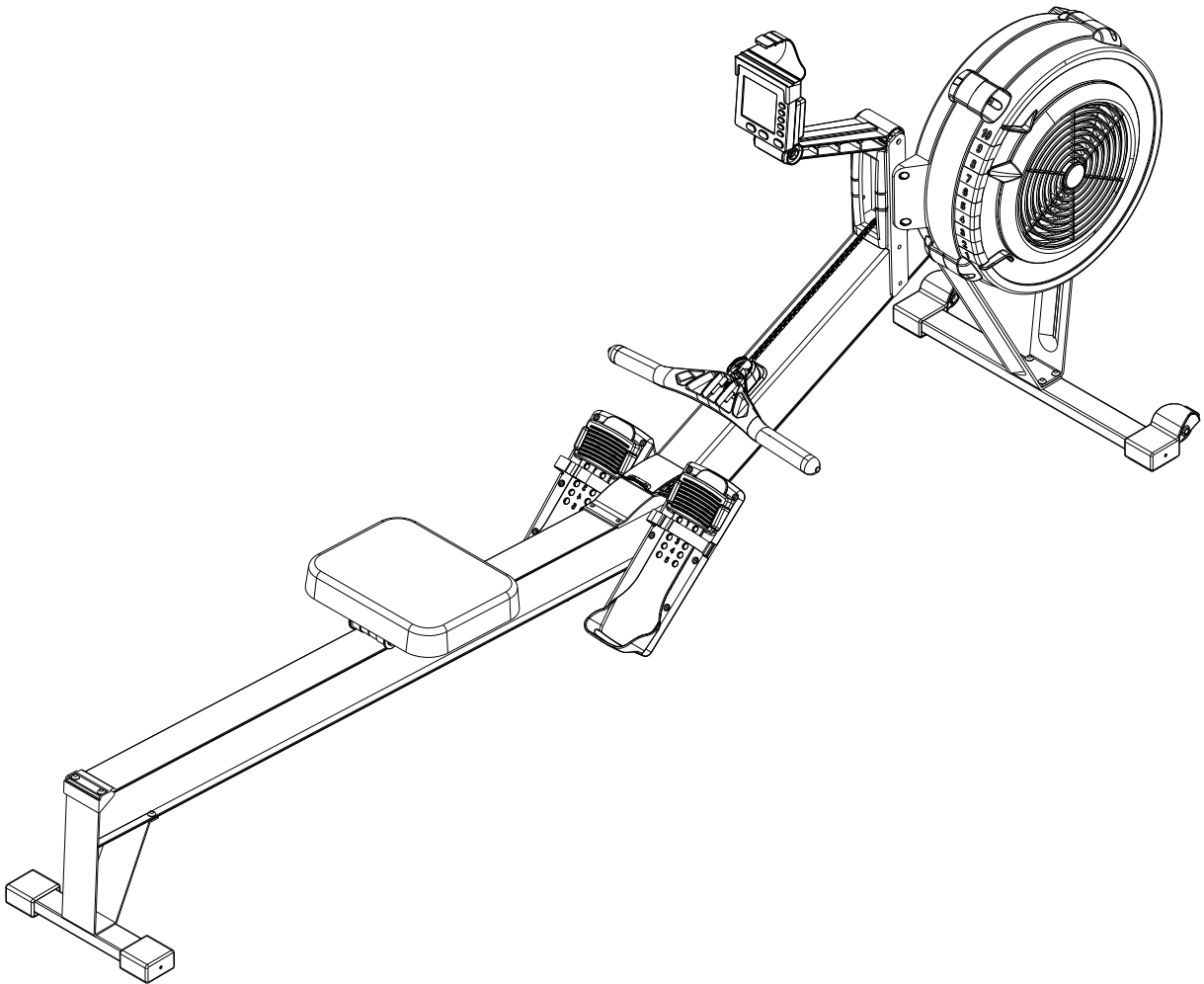

CONGRATULATIONS!

You have completed the assembly of your **AIR ROWER.**

Assembly Instruction

FIGURE 5-1 : HOW TO DISASSEMBLE THE MACHINE

When not in use, you can save space by disassembling the **Monorail Assy(A02)** from the **Main Frame (A01)** by following below steps. **(SEE PAGE 25~27)**

Step 1:

Lift up Monitor Arm (G44) to be located aside to the Flywheel Assy (G10).

Step 2:

Store the Handle (G03) back to the front position of Chain Guide (G43).

FIGURE 5-1 :

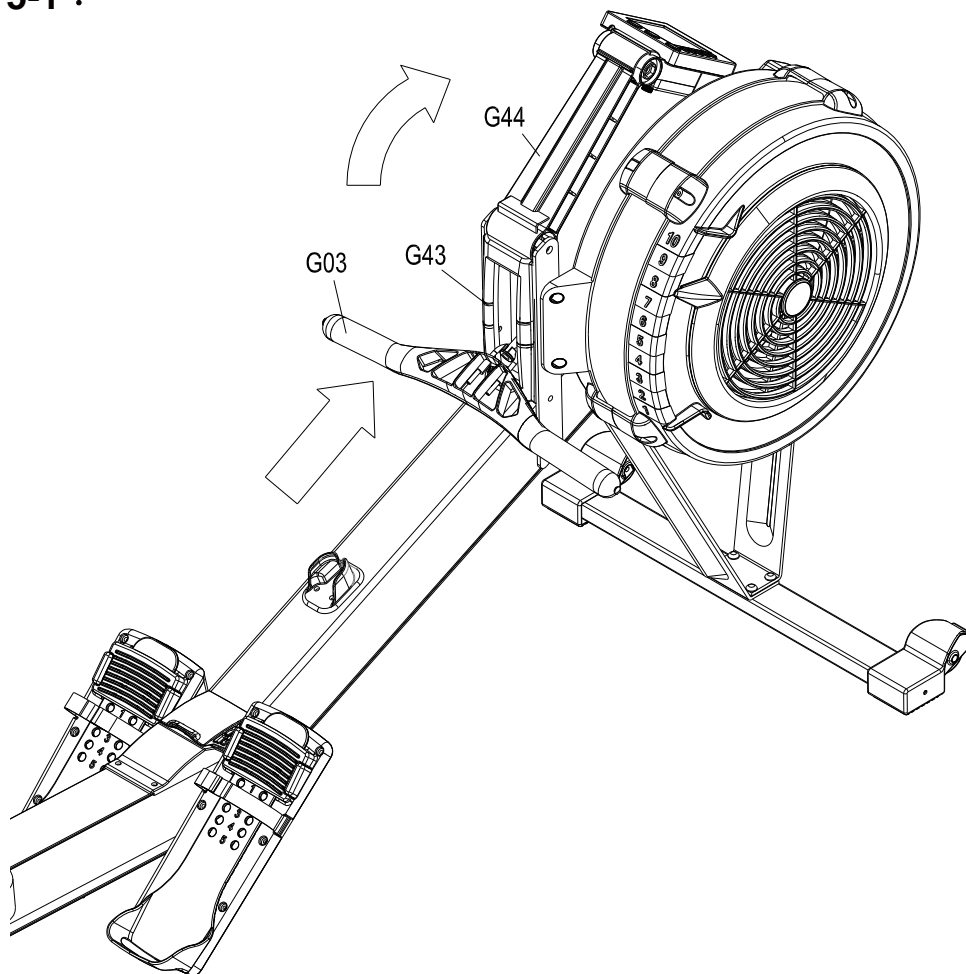

Assembly Instruction

FIGURE 5-2 : HOW TO DISASSEMBLE THE MACHINE

Release up the Main Connecting Cap (G02) from the Main Frame (A01).

FIGURE 5-2

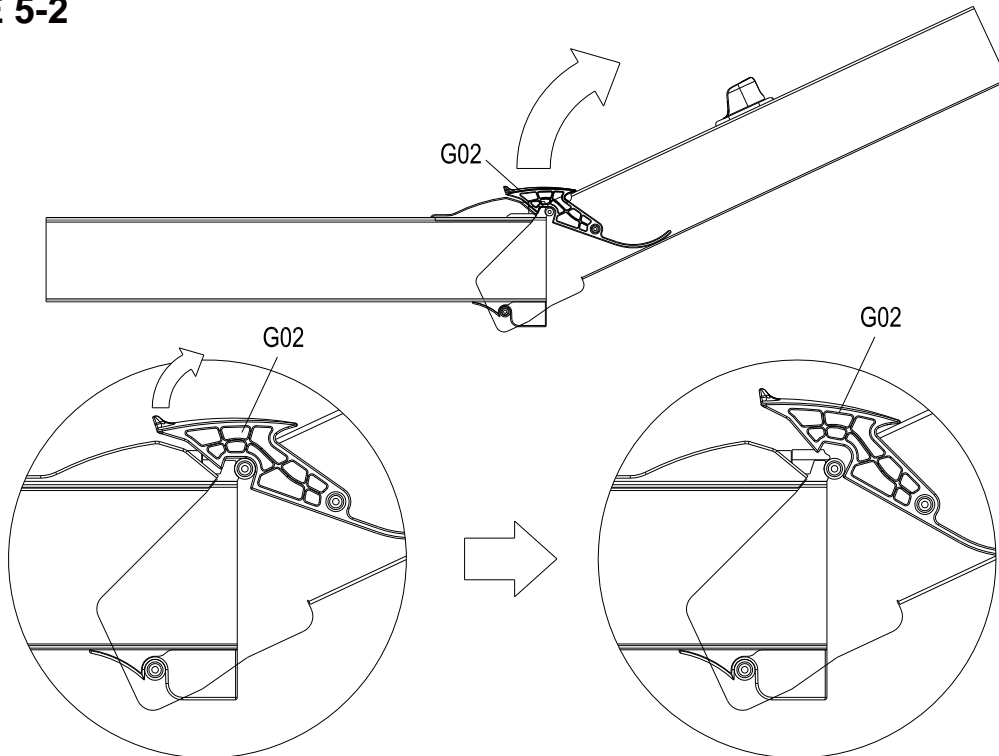
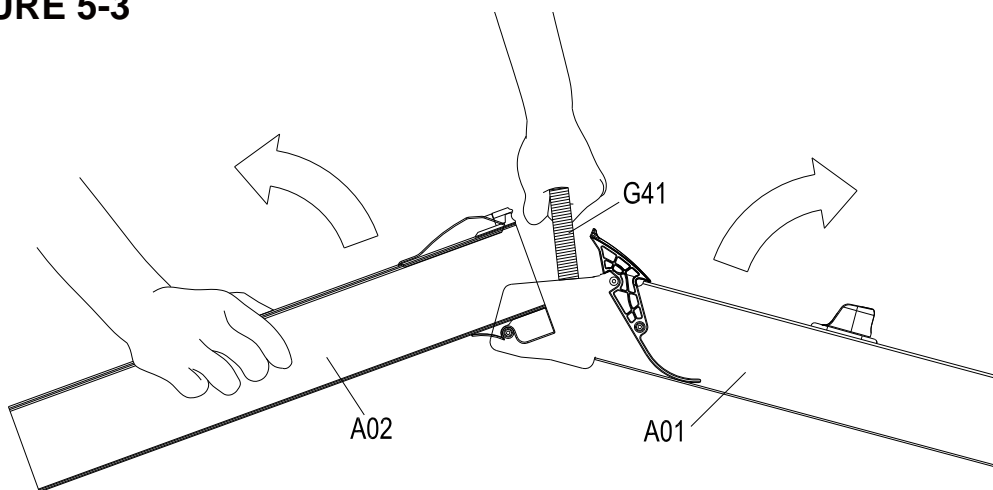

FIGURE 5-3 : HOW TO DISASSEMBLE THE MACHINE

Lift up the Monorail Assy (A02) and the Main Frame Assy (A01) separately till these two assemblies are apart from each other.

FIGURE 5-3



Assembly Instruction

FIGURE 5-4 : HOW TO DISASSEMBLE THE MACHINE

The Monorail Assy (A02) and the Main Frame Assy (A01) are disassembled completely, then you may make these two sections upright for storage to save space.

FIGURE 5-4

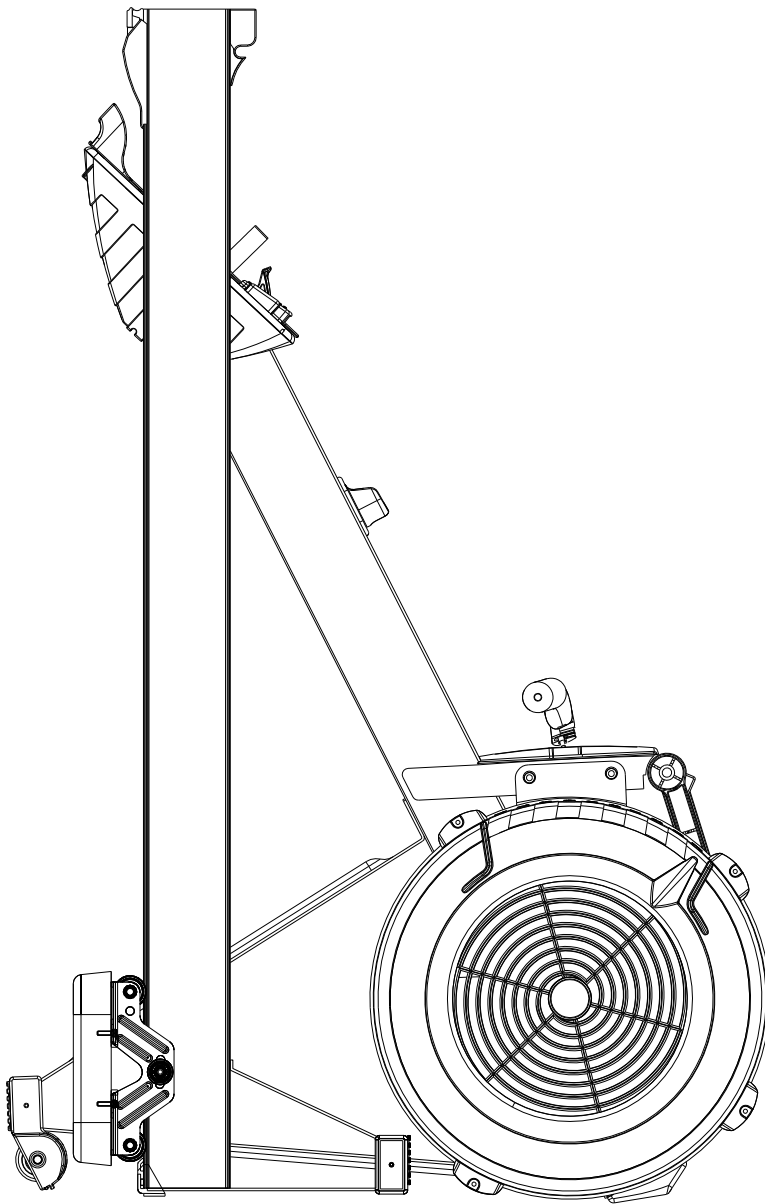

Exploded View

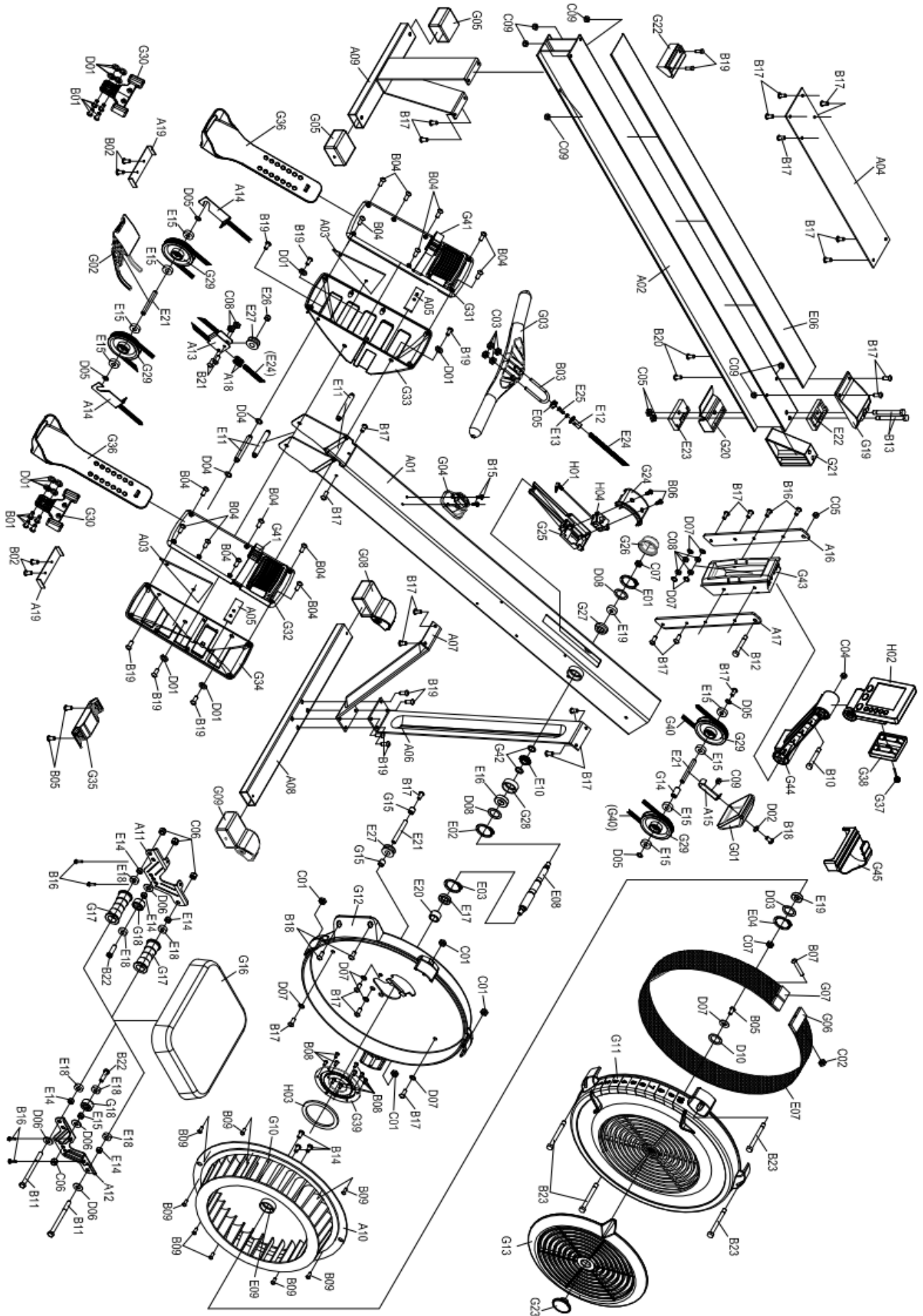

Part List

NO.	PART NAME	QTY
A01	ALUMINUM MAIN FRAME	1
A02	ALUMINUM MONORAIL ASSY	1
A03	REINFORCING PLATE	2
A04	LOWER DECORATION PLATE(ALUMINUM)	1
A05	REINFORCING BRACKET	2
A06	FRONT FOOT LEG(LONG)(ALUMINUM)	1
A07	FRONT FOOT LEG(SHORT)(ALUMINUM)	1
A08	FRONT STABILIZER	1
A09	REAR STABILIZER ASSY	1
A10	FLYWHEEL BALANCED ASSY	1
A11	SEAT CARRIAGE(LEFT SIDE)	1
A12	SEAT CARRIAGE(RIGHT SIDE)	1
A13	CORD PULLEY MOUNTING PLATE	1
A14	CORD ADJUSTMENT HOOK PLATE	2
A15	END CAP HOOK	1
A16	MONITOR ARM SUPPORT BRACKET(LEFT) (ALUMINUM)	1
A17	MONITOR ARM SUPPORT BRACKET(RIGHT) (ALUMINUM)	1
A18	CHAIN CONNECTOR(STAINLESS)	2
A19	SUPPORT PLATE	2
B01	TP 4*12mm SCREW(SILVER)	8
B02	TP 4*8mm SCREW(BLACK)	4
B03	U BOLT(3/4*1/4)(STAINLESS)	1
B04	10*1/2 TFS SCREW(STAINLESS)	14
B05	10*3/4 TFS SCREW(STAINLESS)	3
B06	φ 8mm PAN HEAD PHILLIPS SCREW(BLACK)	2
B07	#6*2 PHILLIPS SCREW(STAINLESS)	1
B08	M4*P0.7*6L PHILLIPS SCREW(SILVER)	9
B09	M5*8L PHILLIPS SCREW(SILVER)	8
B10	3/8-16*3 SCREW(STAINLESS)	1
B11	3/8-16*4.5 SCREW(BLACK)	2
B12	3/8-16*4 SCREW(STAINLESS)	1
B13	3/8-16*5.5 SCREW(STAINLESS)	2
B14	M4*P0.7*10L HEX SCREW(BLACK)	3

B15	M6*P1.0*12L HEX SCREW(STAINLESS)	2
B16	M6*P1.0*15L HEX SCREW(STAINLESS)	6
B17	M6*P1.0*15L HEX SCREW(LICOTTED)(STAINLESS)	26
B18	M6*P1.0*20L HEX SCREW(STAINLESS)	3
B19	M6*P1.0*20L HEX SCREW(LICOTTED)(STAINLESS)	12
B20	M4*12L SELF-DRILLING SCREW(STAINLESS)	2
B21	M6*P1.0*25L ROUND HEX HEAD SCREW(STAINLESS)	2
B22	3/8-16*1.25 SCREW(BLACK)	2
B23	φ 9.3mm ROUND HEAD SCREW(STAINLESS)	4
C01	#10 HEX NUT(φ 9.3mm ACROSS FLAT)(STAINLESS)	4
C02	#6 HEX NUT(φ 8.0mm ACROSS FLAT)(STAINLESS)	1
C03	1/4-20 LOCK NUT(STAINLESS)	2
C04	3/8-16 HEX NUT(STAINLESS)	1
C05	3/8-16 LOCK NUT(STAINLESS)	3
C06	3/8-16 LOCK NUT(BLACK)	4
C07	M10*P1.25*10t NYLON NUT(BLACK)	2
C08	M6*P1.0*6.0t LOCK NUT(BLACK)	6
C09	M6 HEX NUT(φ 10mm ACROSS FLAT)(STAINLESS)	7
D01	φ 6-1t SPRING WASHER(BLACK)	12
D02	φ 12* φ 6*1.0t FLAT WASHER(BLACK)	1
D03	φ 18* φ 12.8*1.0mm STAINLESS WASHER	1
D04	φ 19* φ 10*3.0t WASHER(BLACK)	2
D05	φ 23* φ 10*1.0t WASHER(BLACK)	3
D06	φ 26* φ 10*2.0t FLAT WASHER(BLACK)	4
D07	φ 30* φ 6*1.5t FLAT WASHER(BLACK)	9
D08	φ 34.7* φ 20.1*0.5mm STAINLESS WASHER	1
D09	φ 41.2* φ 25.1*0.5mm STAINLESS WASHER	1
D10	M26 WAVE WASHER(BLACK)	1
E01	R-29 RING	1
E02	R-32 RING	1
E03	R-35 RING	1
E04	R-42 RING	1
E05	CHAIN FIXING RING	1
E06	STAINLESS TRACK	1
E07	STAINLESS SHEET	1

E08	AXLE	1
E09	AXLE SPACER	1
E10	AXLE SPROCKET	1
E11	HANGER SHAFT	3
E12	CHAIN SPACER(STAINLESS)	1
E13	CHAIN WASHER	1
E14	SEAT ROLLER SPACER	6
E15	6000 ZZ PRECISE BEARING	8
E16	6003 Z-ECM PRECISE BEARING	1
E17	6804 ZZ PRECISE BEARING	1
E18	R6 ZZ PRECISE BEARING	6
E19	R8 ZZ PRECISE BEARING	2
E20	CLUTCH BEARING	1
E21	CORD PULLEY AXLE	3
E22	UPPER DIECAST HANGER	1
E23	LOWER DIECAST HANGER	1
E24	CHAIN	1
E25	CHAIN PULL SHAFT(STAINLESS)	1
E26	CHAIN PULLEY SPACER	1
E27	CHAIN IDLER PULLEY	2
G01	END CAP	1
G02	MAIN FRAME CONNECTING CAP	1
G03	HANDLE	1
G04	HANDLE HOOK	1
G05	REAR FOOT CAP	2
G06	CONNECTOR NUT SIDE	1
G07	CONNECTOR SCREW SIDE	1
G08	FOOT CASTER(LEFT)	1
G09	FOOT CASTER(RIGHT)	1
G10	FLYWHEEL	1
G11	FLYWHEEL FRONT COVER	1
G12	FLYWHEEL BACK COVER	1
G13	FLYWHEEL DAMPER	1
G14	ϕ 14* ϕ 10*24.4t SPACER(POM)	1
G15	ϕ 14* ϕ 10*30.5t SPACER(POM)	2
G16	SEAT	1
G17	SEAT ROLLER(LONG)(POM)	2

G18	SEAT ROLLER(SHORT)(POM)	2
G19	MONORAIL FRONT COVER(UPPER)	1
G20	MONORAIL FRONT COVER(LOWER)	1
G21	MONORAIL FRONT END CAP	1
G22	MONORAIL REAR END CAP	1
G23	CENTRAL CAP	1
G24	GENERATOR TOP COVER	1
G25	GENERATOR BASE COVER	1
G26	SHAFT CAP	1
G27	28mm BEARING RUBBER CAP	1
G28	35mm BEARING RUBBER CAP	1
G29	CORD PULLEY	4
G30	FLEX FOOT ADJUSTER	2
G31	LEFT UPPER FOOT STRETCHER	1
G32	RIGHT UPPER FOOT STRETCHER	1
G33	LEFT LOWER FOOT STRETCHER	1
G34	RIGHT LOWER FOOT STRETCHER	1
G35	FOOT STRETCHER CONNECTING CAP	1
G36	FLEX FOOT	2
G37	BATTERY CAP GROMMET	1
G38	BATTERY CAP	1
G39	WHEEL CAP	1
G40	BUNGEE CORD	1
G41	FOOT STRAP WITH BUCKLE	2
G42	SPROCKET WASHER(ϕ 20* ϕ 16*2.7t)	2
G43	CHAIN GUIDE	1
G44	MONITOR ARM	1
G45	MONITOR TOP SHROUD	
H01	GENERATOR WIRE	1
H02	MONITOR	1
H03	MAGNET	1
H04	GENERATOR	1