

- 1、 a. The 11 is connected to the 4 and 9 by using ① and ②, and then it is connected to the 3 by using ① and ②.
- b. The 4,9,11 and the bottom of the 1 and 5 are installed with ⑦.

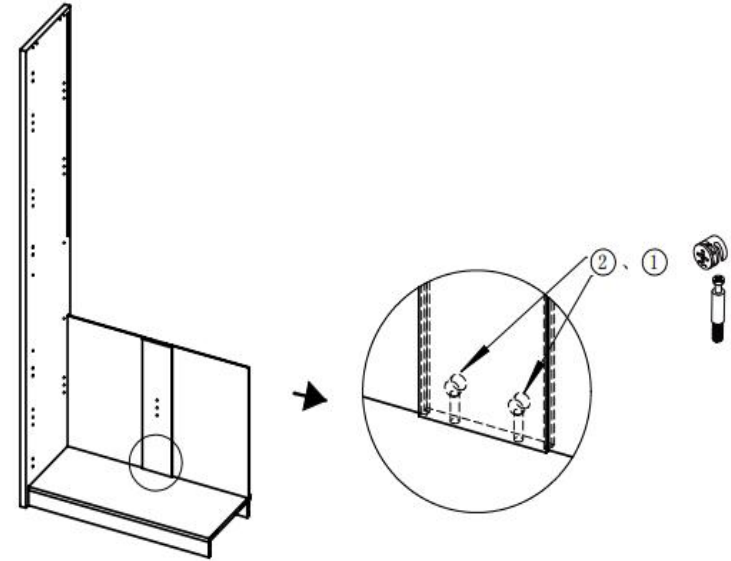

- 3、 The 12 is fixed on the 3 with ① and ②, and then inserted the 15.

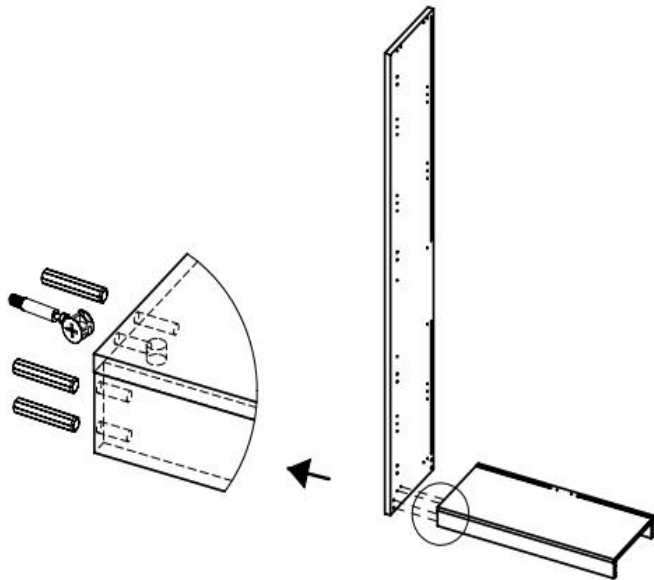

- 2、 The 1 adopts the ①, ② and ⑥ to connect the 3, 4 and 9 .
- Note: The cabinet can be put down to fix the buckle wheel under the bottom plate;

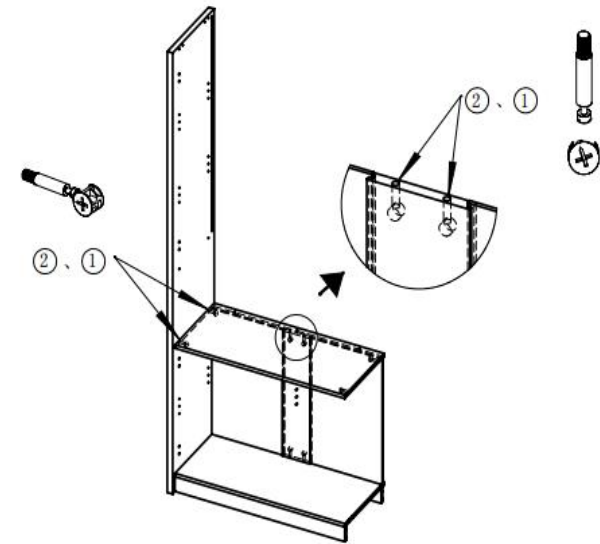

4. Connect the 8 with ① and ② to the 1 and 12 at the same time.

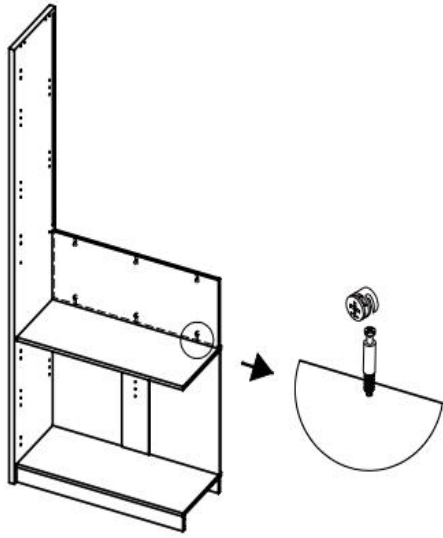

5、 The 7 is connected with the 8 by ① and ②.

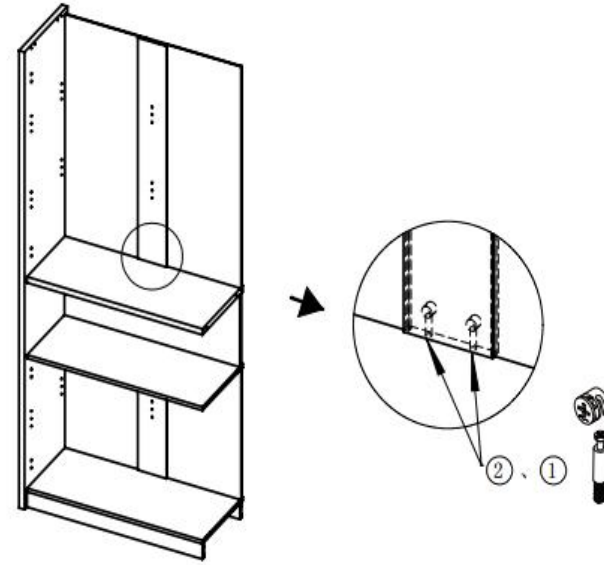

7、 The 13 adopts ① and ② to connect and fix on the 2, and then insert the 14.

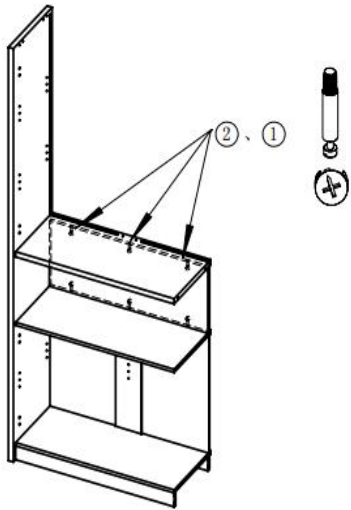

6、 The 2 and 7 are connected with ① and ②.

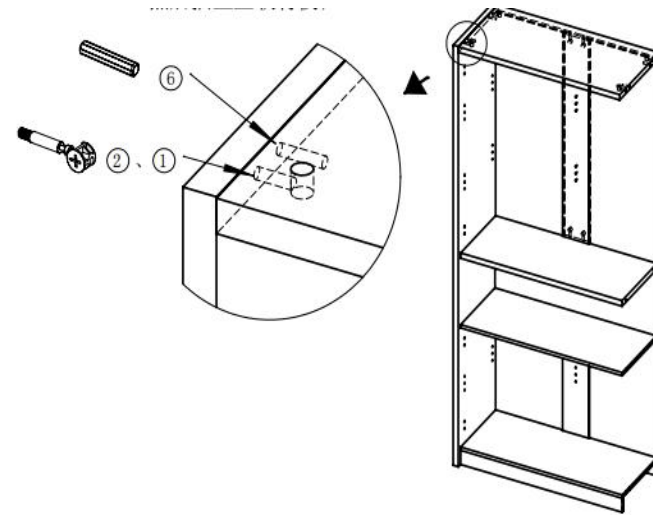

8、 At the same time, the 6 is connected to the 13 with the ① and ②, and the ①, ② and ⑥ are used to Connect the 1, After the connection is complete, secure it with buckle wheel

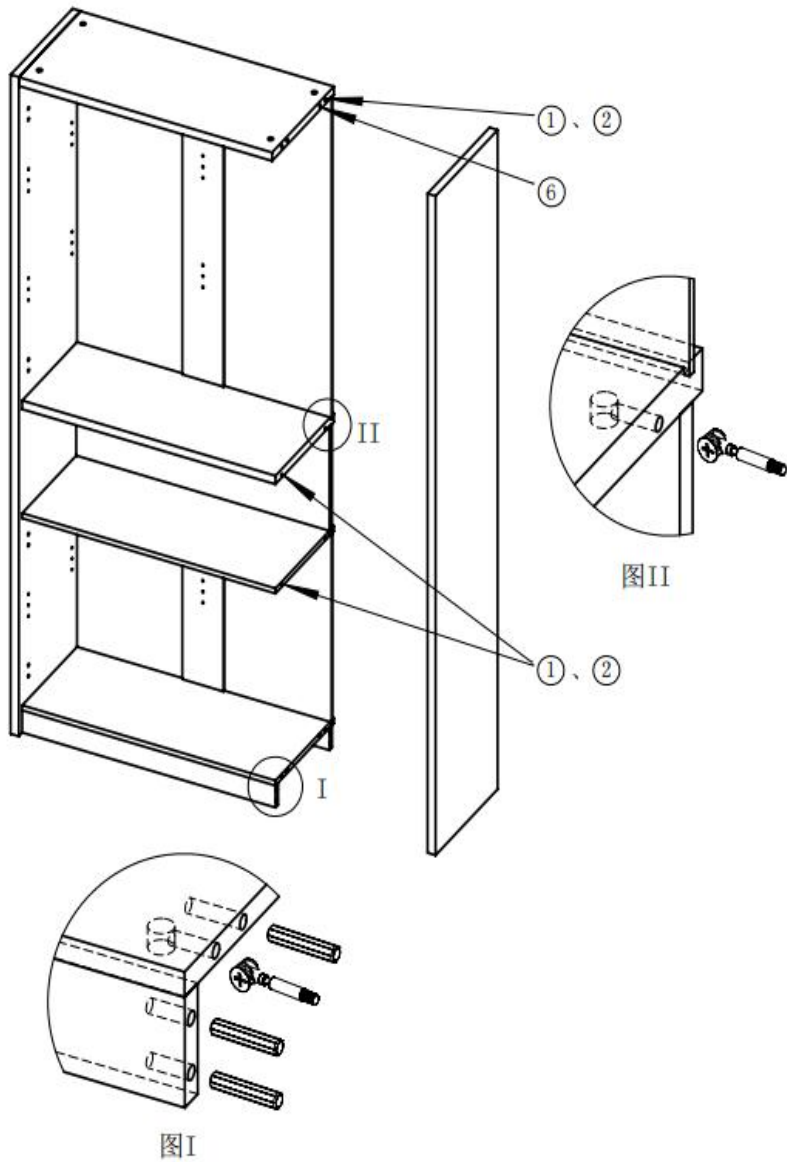

9、The 5 is connected to the cabinet with ①, ② and ⑥.

Note: The cabinet can be put down to fix the buckle wheel under the 3.

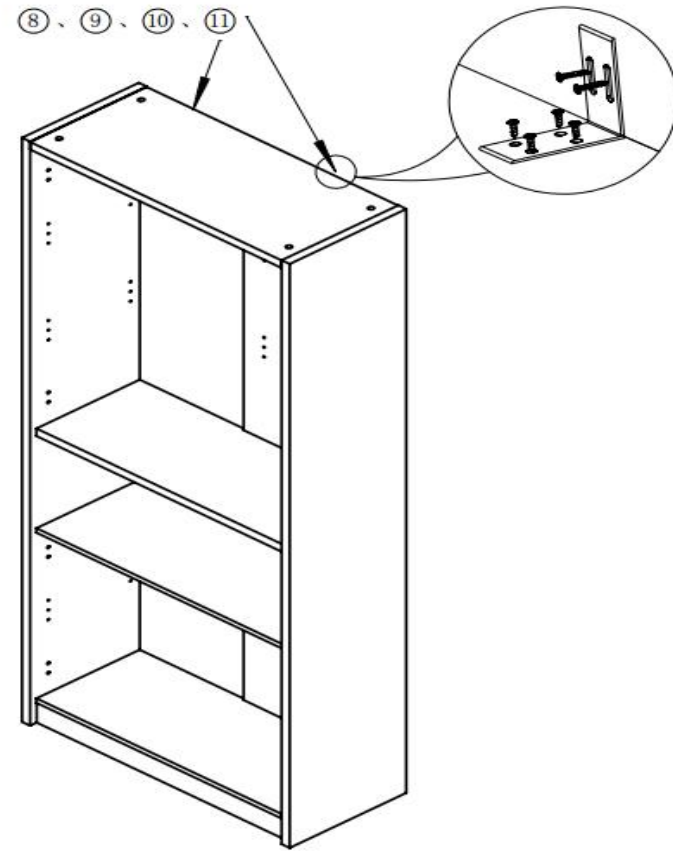

#### 10、 Installation guide of fixed parts:

1. Move the molding cabinet (without the door panel) to the installation position, and press the ⑨ four-hole surface close to the 6. And perpendicular to the wall, confirm the connection hole position of the pilot hole, then move the cabinet body;
2. Drill holes in the wall ( $\phi 10$  deep 50mm), and pre-bury the ⑩, using ⑪ fix the ⑨ on the wall;
3. Move the cabinet to the designated position, and connect the cabinet to ⑨ with ⑧  
(Ensure that the cabinet is perpendicular to the ground), and then install the door panel after fixing.

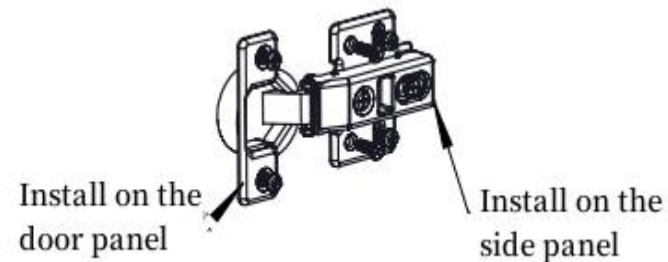
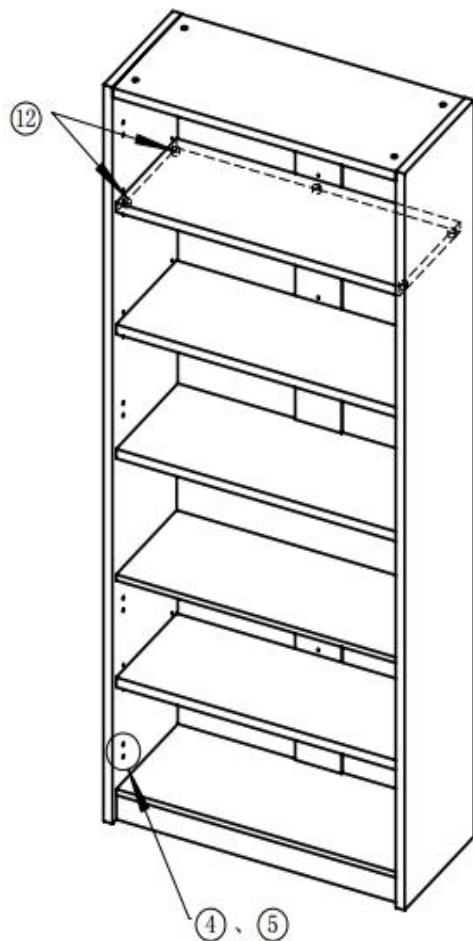
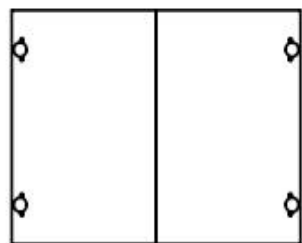
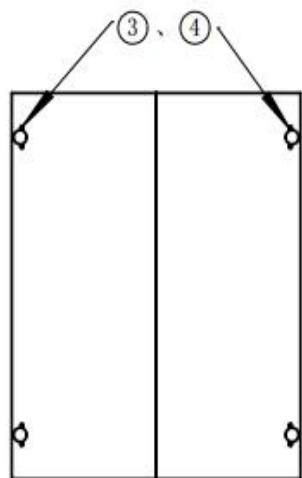





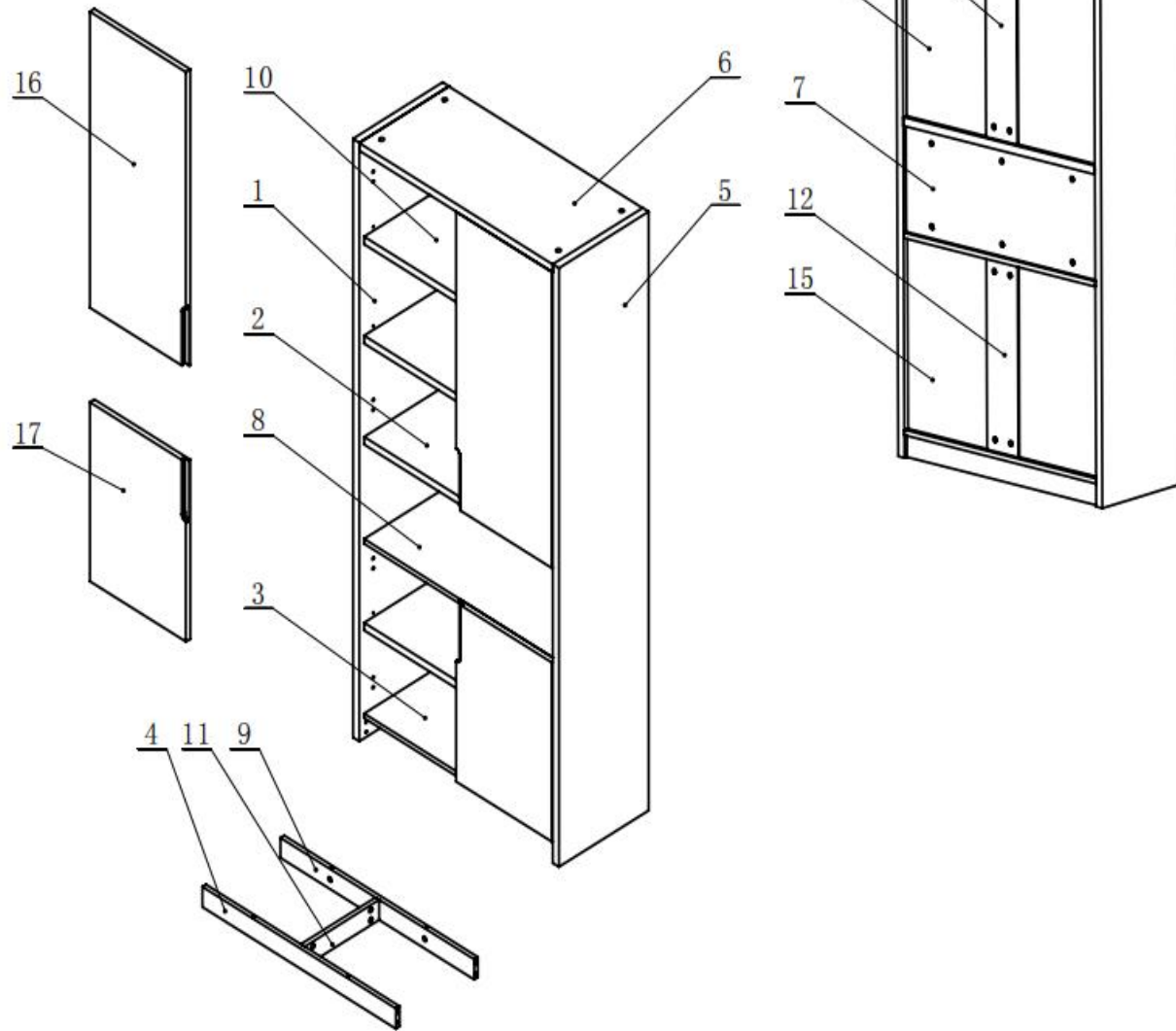





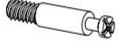

- 11、 a. Install the ⑫ on the 1 and 5 in the corresponding position, and then place the 10 (as shown in the picture);  
 When installing the door panel, you can remove the 10 first, and then put it on after the door panel is installed.
- b. The ③ Use two ④ Installed in the corresponding position of the door panel;
- c. Each hinge is connected with the side plate by two ④ and two ⑤.
- (Note: Install the two nickel-plated screws on the corresponding rubber plug holes first, and then tighten the self-tapping nails)

# Quanu全友

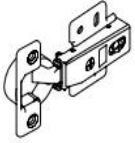

Itme	Name	Spec.	Qty
1	The left side plate	1932X364	1
2	The upper middle separation board	785X344	1
3	Base plate	785X344	1
4	Front Pulling strip	785X65	1
5	The right side plate	1932X364	1
6	Top plate	785X364	1
7	Backplane	785X305	1
8	The lower middle separation board	785X344	1
9	Back Pulling strip	785X65	1
10	Removable plate	785X317	3
11	Middle Pulling strip	302X65	1
12	Lower backing strip	548X128	1
13	Upper backing strip	933X128	1
14	Upper backplane	941X337	2
15	Lower backplane	556X337	2
16	Upper left door panel	955X389	1
17	Lower left door panel	578X389	1
18	Upper right door panel	955X389	1
19	Lower right door panel	578X389	1

## Hardware List

No.	Name	Picture	Qty.	No.	Name	Picture	Qty.	No.	Name	Picture	Qty.
①	Large tapping buckle bar 34mm		38	⑥	8*35 Wood tip		16	⑪	M4*30 cross countersunk head tapping screw		4
②	Large buckle wheel		38	⑦	Diameter 16 rubber foot nails		6	⑫	Plane fittings		15
③	Embedded hydraulic hinge large base four holes		8	⑧	M3.5*14 cross countersunk head tapping screw		8	⑬	Furniture sticker		12
④	M4*12 cross countersunk head nickeled screw		32	⑨	80*80 Angle iron		2				
⑤	M4*14 cross countersunk head tapping screw(nickeled)		16	⑩	Expansion rubber plug		4				