

1、
Metal leg ⑰ are installed under the 9 with ⑦.

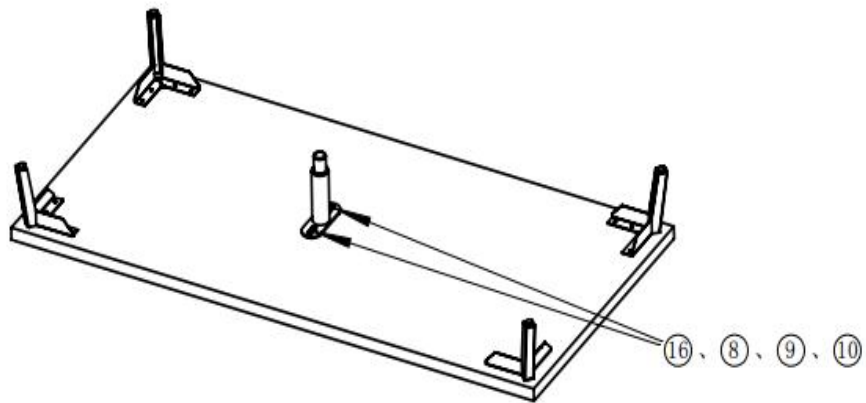

2、
The adjusting leg ⑯ using ⑧, ⑨ and ⑩, fixed under the 9;
(Note: After installation of all the leg, ensure that the height of the adjusted leg is consistent with the other 4 metal leg)

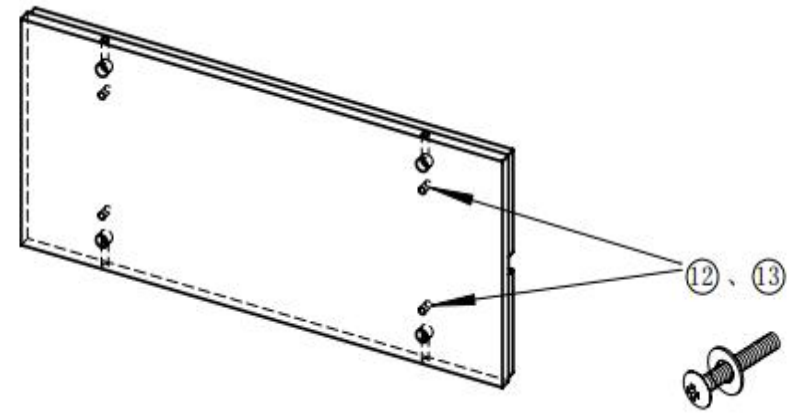

3、
The 14 is fixed with 7 by ⑫, ⑬.

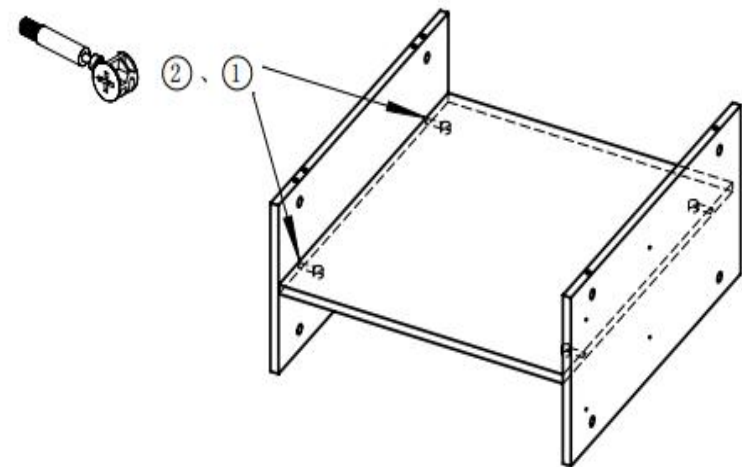

4、
The 1 adopts ② and ① to connect the 3 and 4.

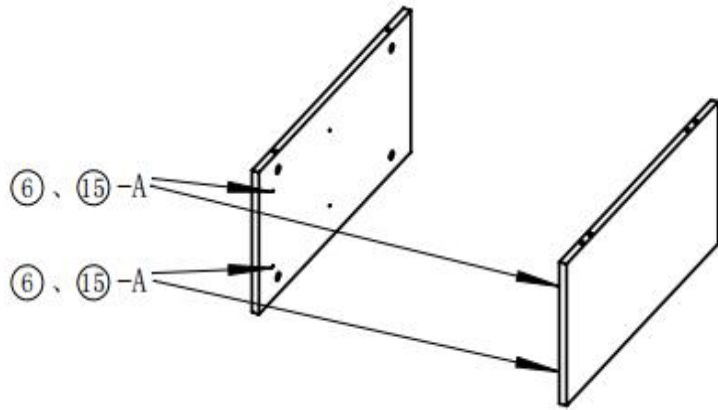

5、
Inside of the 2 and 3 use ⑥ install two pairs
of drawer rail ⑮-A.

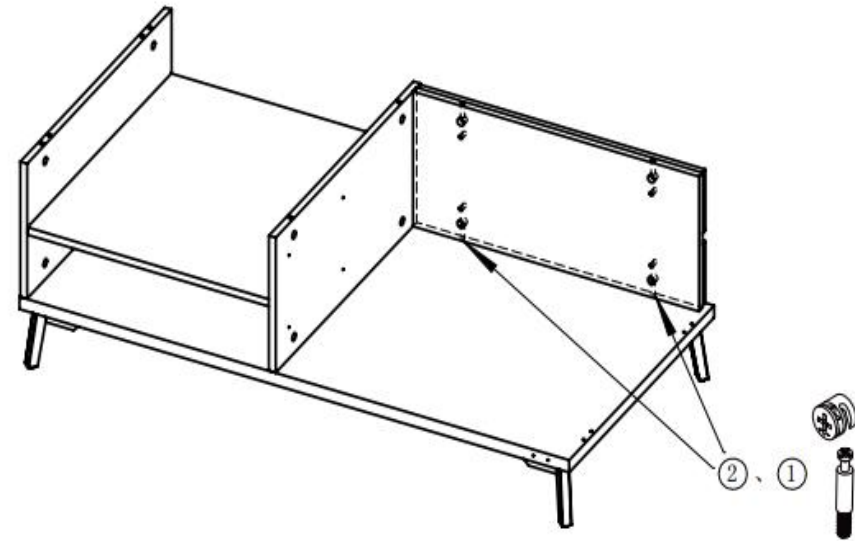

7、
The 7 is connected and fixed on the 9 with ② and
①.

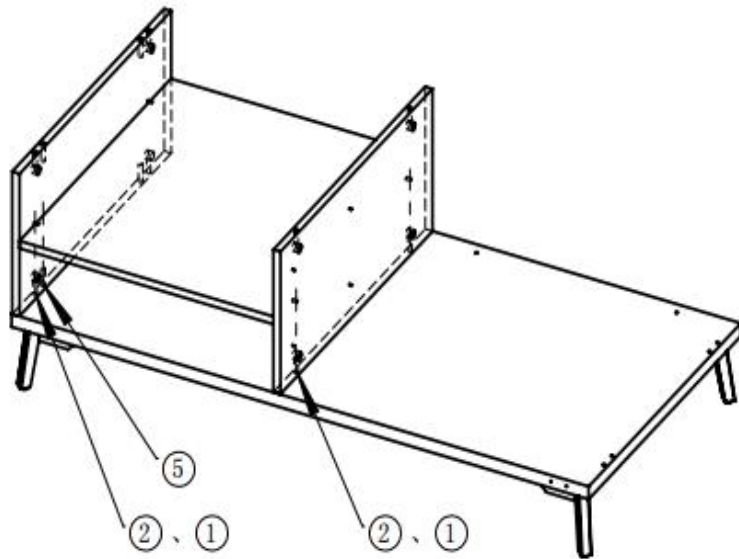

6、
At the same time, the 4 used ②, ① and ⑤, and the
3 use ② and ① are connected and fixed on the 9.

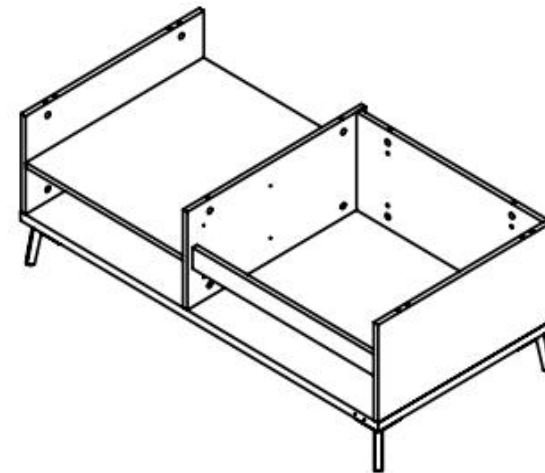

8、
a: The 17 adopts ② and ① to connect the 3.
b: The 2 is connected with the 9 by ②, ① and ⑤.
c: At the same time, use ② and ① connected to the
17.

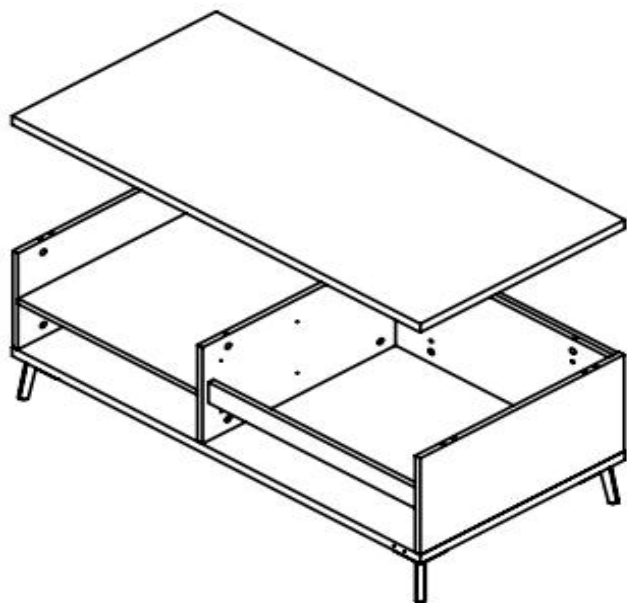

9、
The 8 adopts ②, ① and ⑤ to connect the fixed cabinet

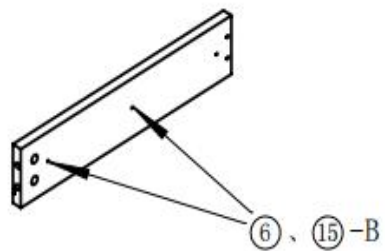
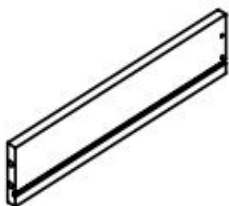

10、
Install and fixed drawer rail ⑮-B on the 10 and 11 by ⑥.

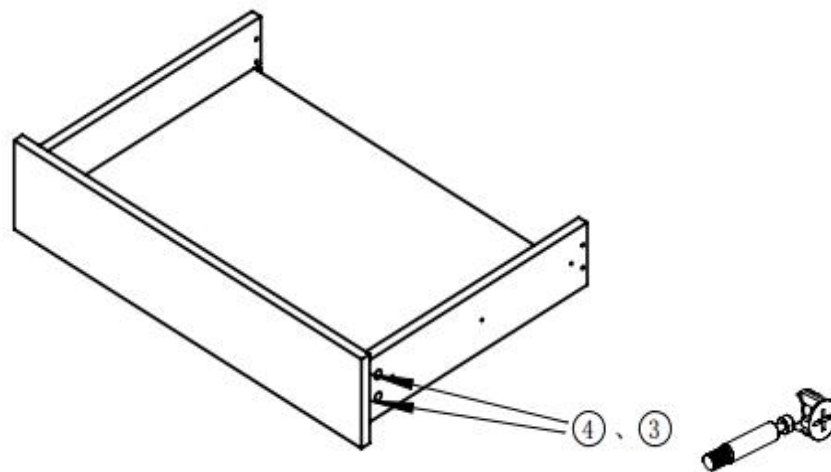

11、
The 10 and 11 adopt ③, ④ to connect and fixed drawing surface and insert the 13.

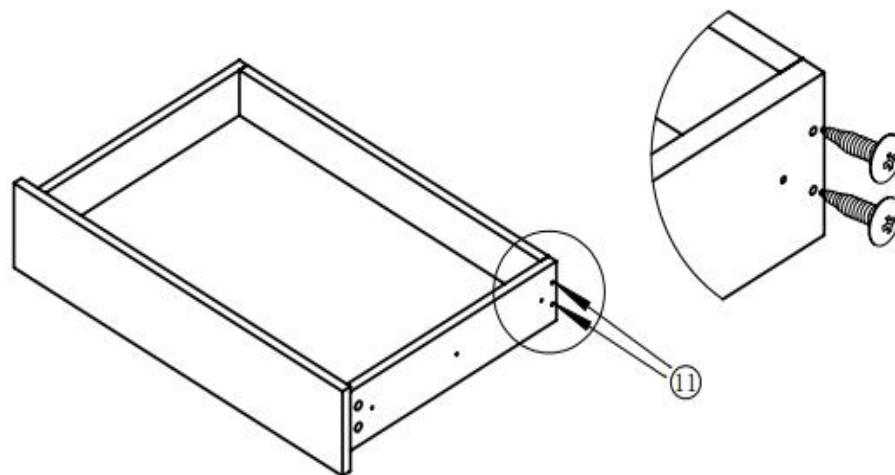

12、
Use ⑪ connected to fix the 10, 11 and 12.



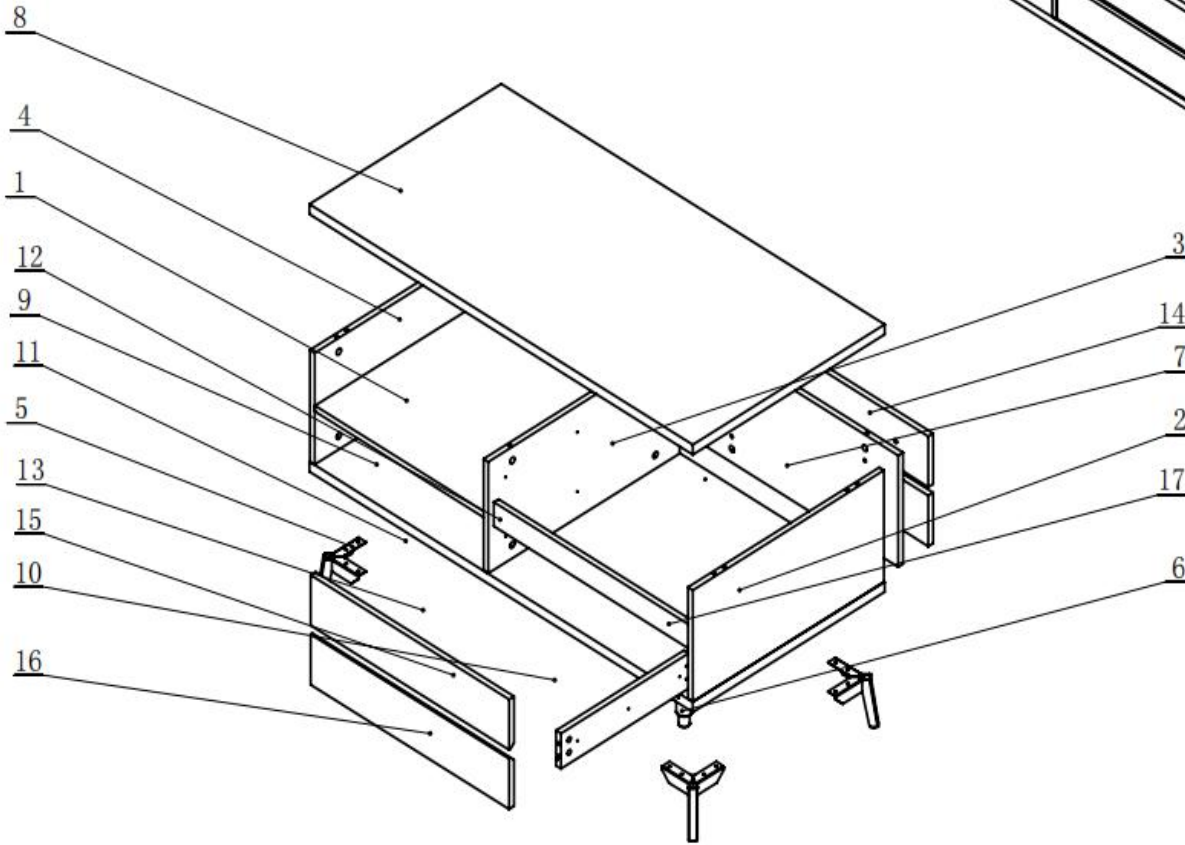
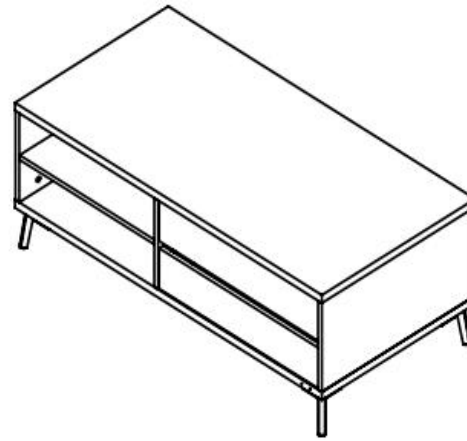













QUANU 全友

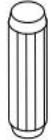

Item	Name	Spec.	Qty
1	Clapboard	528X596	1
2	Right side plate	278X598	1
3	Middle side plate	278X598	1
4	Left side plate	278X598	1
5	Metal leg		4
6	The mid-leg		1
7	Backplane	625X278	1
8	Top plane	1200X600	1
9	Base plate	1200X600	1
10	The right drawer side	400X88	2
11	The left drawer side	400X88	2
12	Drawer end	568X88	2
13	Drawer bottom	393X577	2
14	Fake drawer surface	621X126	2
15	Upper drawer surface	621X126	1
16	Lower drawer surface	621X126	1
17	drawer check rail	625X60	1

13、
the fastener hole pasted (14), Insert the drawer, adjust the distance between the drawers to 2mm, the installation is complete.

Hardware List

No.	Name	Picture	Qty.	No.	Name	Picture	Qty.	No.	Name	Picture	Qty.
①	Large tapping buckle bar		24	⑦	M4*16 cross countersunk head tapping screw		16	⑬	Dia. 6mm flat washer		4
②	Large buckle wheel		24	⑧	M8*20 cross round head galvanized screw		2	⑭	Furniture sticker		4
③	Small tapping buckle bar		8	⑨	Dia. 8mm flat washer		2	⑮	400MM three-section rail (width 36mm)(black)		2
④	Small buckle wheel		8	⑩	Dia. 8mm spring pad		2	⑯	Adjustable support leg 120*42* (110-190)H(with pad)		1
⑤	8*35 Wood tip		8	⑪	M3*30 cross countersunk head tapping screw		8	⑰	metal leg 112*137*123H (with rubber pads)		4
⑥	M3.5*14 cross countersunk head tapping screw		24	⑫	M6*25 cross chamfered galvanized screw		4				