

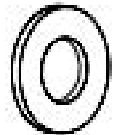









## Hardware List

No.	Name	Picture	Qty.	No.	Name	Picture	Qty.
①	Lengthening big buckle bar		4	⑦	Dia. 8mm flat washer		16
②	Large buckle wheel		4	⑧	M8 load binder		4
③	M6*12 cross round head galvanized screw		8	⑨	M8*50 cross round head galvanized screw		12
④	M8*70 cross round head galvanized screw		4	⑩	Diameter 16 rubber foot nails		4
⑤	M6*45 cross chamfered galvanized screw		10	⑪	PVC adhesive cap		8
⑥	Dia. 6mm flat washer		10	⑫	Iron triangle		2

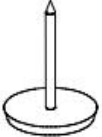

- 1、
- a. The 2 and 5 adopts ② and ① to connected to the 1.
  - b. The ⑬ are fixed on the 1,2 and 5 by ③.

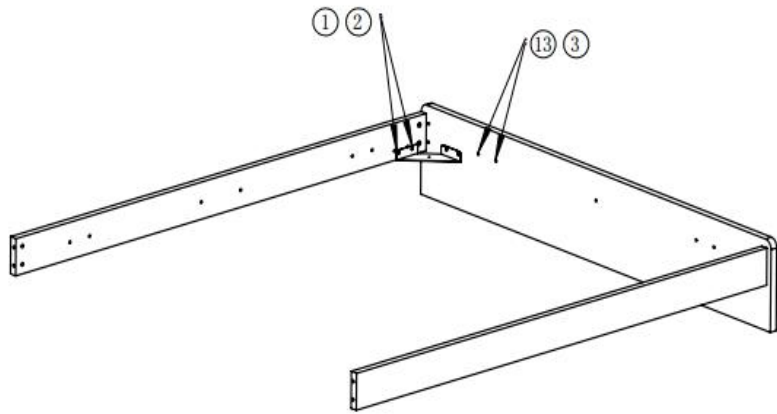
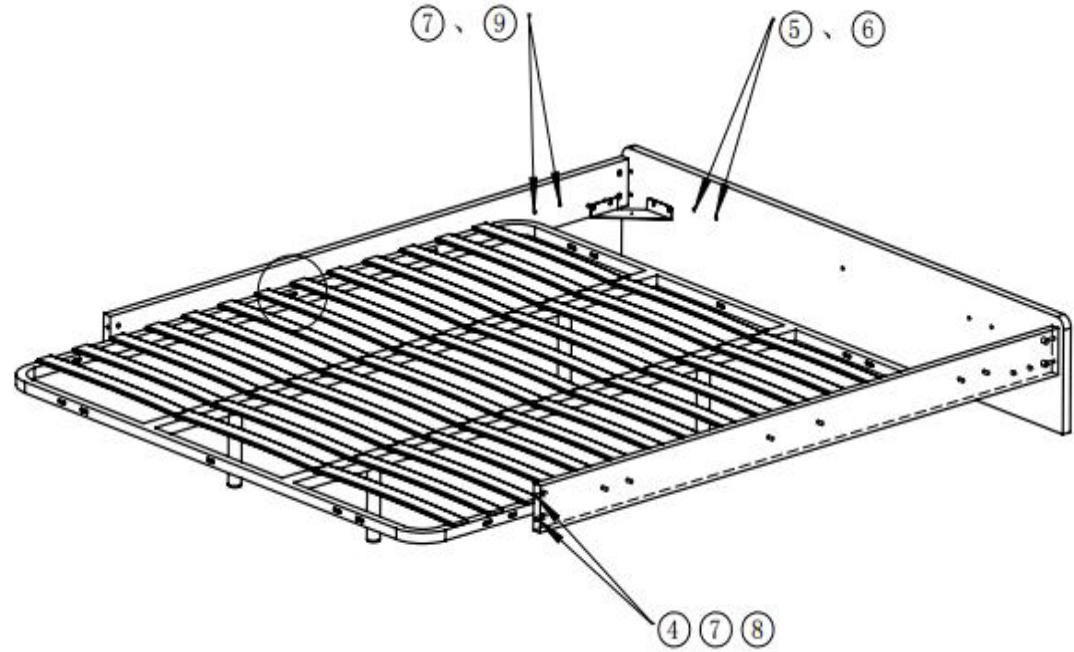

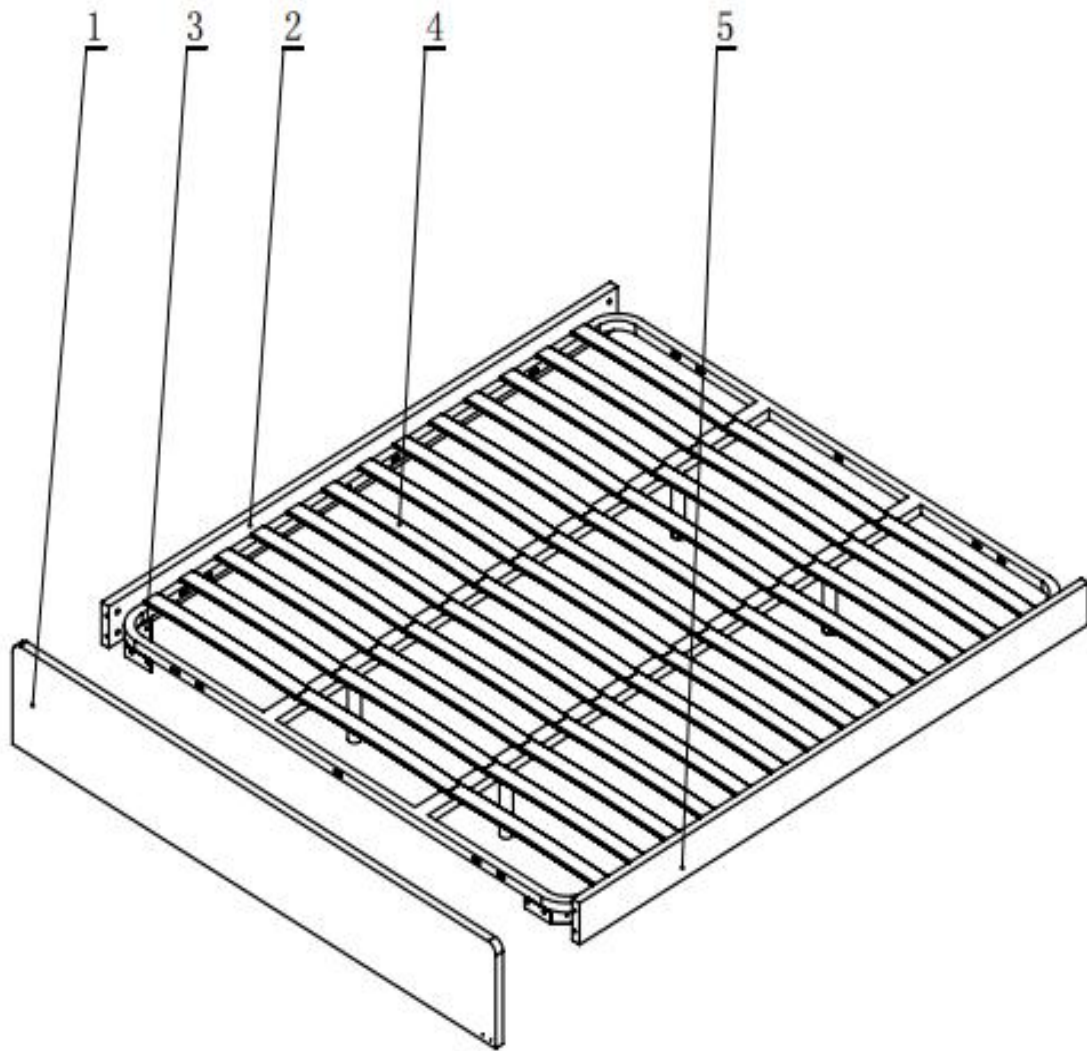

- 2、
- a. The 2 and 5 adopts ⑨ and ⑦ to connect and fixed the 4.
  - b. The ⑤ and ⑥ are used to reinforce the 1 and headboard.
  - c. The bed body adopts ④,⑧ and ⑦ to Connected and fixed with the headboard, the exposed fastener holes are pasted with ⑪, and the bottom is all Uniform installation ⑩, the installation is complete.

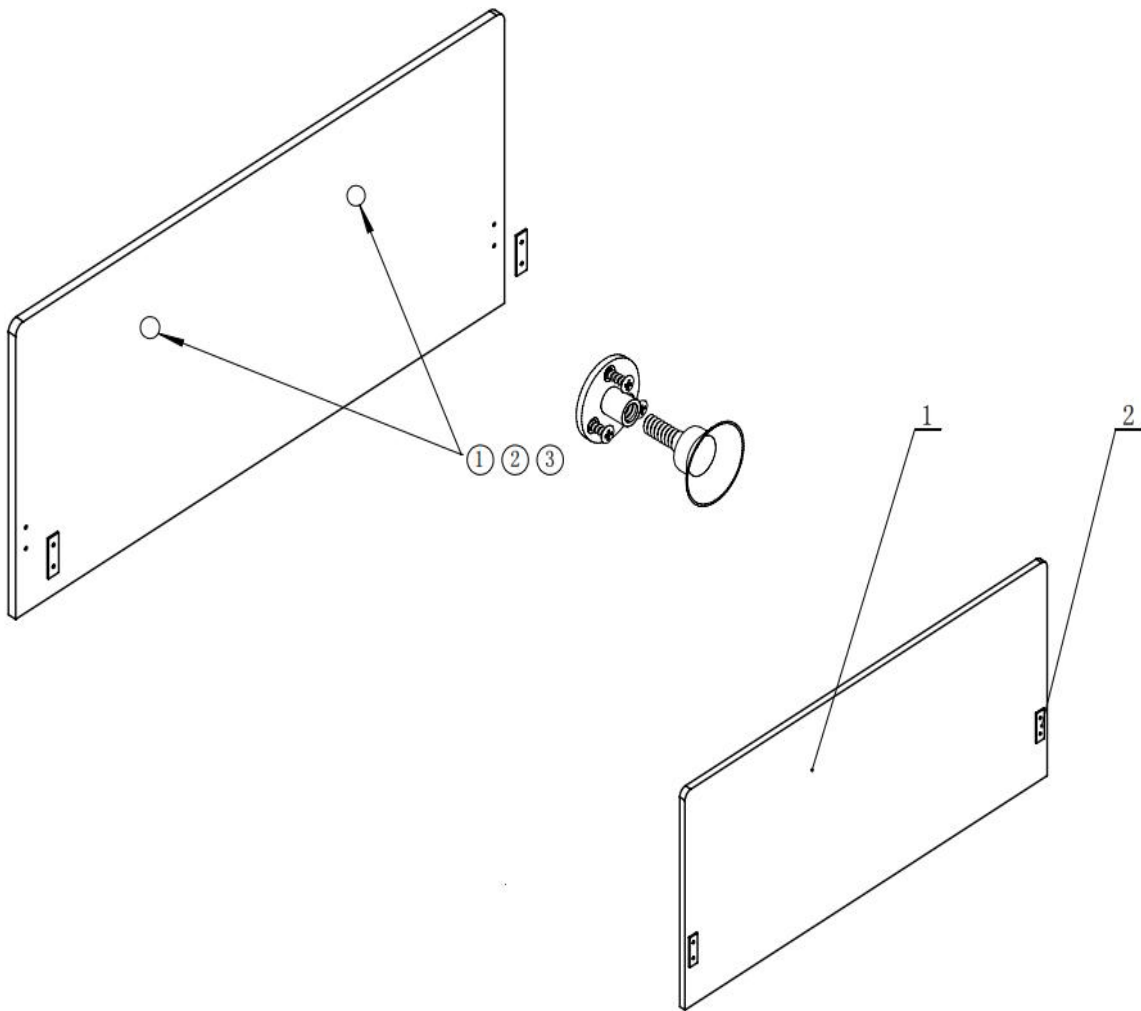

Itme	Name	Spec.	Qty
1	Footboard	1900X320	1
2	Left bedside	2000X130	1
3	Iron triangle		2
4	Bed frame		1
5	Right bedside	2000X130	1



Itme	Name	Spec.	Qty
1	Backrest	1900X880	1
2	sub-plate	120X40	2

Hardware List			
No.	Name	Picture	Qty.
①	M3.5*14 cross countersunk head self-tapping nail		6
②	Rubber soled seat		2
③	pedestal		2

The ③ are symmetrically fixed on the 1 by using ①.  
 Screw down the ② to the ③,  
 After the installation of the headboard and the bed body, move the bed to the place.  
 Rotate the ② to contact the wall, and the installation is complete.