

deli

User Instruction Manual

MITER SAW DL-XD255-E1



Specifications

Blade Diameter: 255mm(10")
Hole Diameter: 25.4mm(1")
Max.Miter Angle: Left 45°, Right 52°
Max.Bevel Angle: Left 45°

Max.Cutting Capacities(H x W)

Bevel Angle	Miter Angle	
	0°	45°(left and right)
0°	135 mm x 65 mm	135 mm x 33 mm
45°(left)	95 mm x 70 mm	95 mm x 35 mm

No load speed (RPM): 6000/min
Dimensions(L x W x H): 600 mm x 435 mm x 420 mm
Net Weight : 11.85kg

> Manufacturer reserves the right to change specifications without notice. Specifications.
> may differ from country to country.

For your Own Safety Read Instruction Manual Before Operating Tool Save it for future reference.

GENERAL SAFETY PRECAUTIONS

(For All Tools)

1. **KNOW YOUR POWER TOOL.** Read the owner's manual carefully. Learn the tool's applications and limitations, as well as the specific potential hazards peculiar to it.
2. **KEEP GUARDS IN PLACE** and in working order.
3. **REMOVE ADJUSTING KEYS AND WRENCHES.** From habit of checking to see that keys and adjusting wrenches are removed from tool before turning it on.
4. **KEEP WORK AREA CLEAN.** Cluttered areas and benches invite accidents.
5. **DON'T USE IN DANGEROUS ENVIRONMENT.** Don't use power tools in damp or wet locations, or expose them to rain. Keep work area well lighted. Don't use tool in presence of flammable liquids or gases.
6. **KEEP CHILDREN AWAY.** All visitors should be kept safe distance from work area.
7. **MAKE WORKSHOP KID PROOF** with padlocks, master switched, or by removing starter keys.
8. **DON'T FORCE TOOL** It will do the job better and safer at the rate for which it was designed.
9. **USE RIGHT TOOL** Don't force tool or attachment to do a job for which it was not designed.

10. **WEAR PROPER APPAREL.** Do not wear loose clothing, gloves, neckties, rings, bracelets, or other jewelry which may get caught in moving parts. Non-slip footwear is recommended. Wear protective hair covering to contain long hair.
11. **ALWAYS USE SAFETY GLASSES.** Also use face or dust mask if cutting operation is dusty. Everyday eyeglasses only have impact resistant lenses, they are NOT safety glasses.
12. **SECURE WORK.** Use clamps or a vise to hold work when practical. It's safer than using your hand and it frees both hands to operate tool.
13. **DON'T OVERREACH.** Keep proper footing and balance at all times.
14. **MAINTAIN TOOLS WITH CARE.** Keep tools sharp and clean for best and safest performance. Follow instructions for lubricating and changing accessories.
15. **DISCONNECT TOOLS** before servicing: when changing accessories such as blades, bits, cutters, and the like.
16. **REDUCE THE RISK OF UNINTENTIONAL STARTING.** Make sure switch is in off position before plugging in.
17. **USERECOMMENDED ACCESSORIES.** Consult the owner's manual for recommended accessories. The use of improper accessories may cause risk of injury to persons.
18. **NEVER STAND ON TOOL.** Serious injury could occur if the tool is tipped or if the cutting tool is unintentionally contacted.
19. **CHECK DAMAGED PARTS.** Before further use of the tool, a guard or other part that is damaged should be carefully checked to determine that it will operate properly and perform its intended function-check and perform its intended function-check for alignment of moving parts, binding of moving parts, breakage of parts, mounting, and any other conditions that may affect its operation. A guard or other part that is damaged should be properly repaired or replaced.
20. **DIRECTION OF FEED.** Feed work into a blade or cutter against the direction of rotation of the blade or cutter only.
21. **NEVER LEAVE TOOL RUNNING UNATTENDED. TURN POWER OFF.** Don't leave tool until it comes to a complete stop.
22. **REPLACEMENT PARTS.** When servicing use only identical replacement parts.
23. **POLARIZED PLUGS.** To reduce the risk of electric shock, this equipment has a polarized plug (one blade is wider than the other). This plug will fit in a polarized outlet only one way. If the plug does not fit fully in the outlet, reverse the plug. If it still does not fit, contact a qualified electrician to install the proper outlet. Do not change the plug in any way.

VOLTAGE WARNING: Before connecting the tool to a power source (receptacle, outlet, etc.) be sure the voltage supplied is the same as that specified on the nameplate of the tool. A power source with voltage greater than that specified for the tool can result in **SERIOUS INJURY** to the user- as well as damaged to the tool, if in doubt, **DO NOT PLUG IN THE TOOL**. Using a power source with voltage less than the nameplate rating is harmful to the motor.

USE PROPER EXTENSION CORD. Make sure your extension cord is in good condition. When using an extension cord, be sure to use one heavy enough to carry the current your product will draw. An undersized cord will cause a drop in line voltage resulting in loss of power and overheating. Table 1 shows the correct size to use depending on cord length and nameplate ampere rating. If in doubt, use the next heavier gage. The smaller the gage number, the heavier the cord.

Ampere Rating		Volts	Total length of cord in feet			
		220 V	25 ft.	50 ft.	100 ft.	150 ft.
More Than	Not More Than	AWG				
0	6		18	16	16	14
6	10		18	16	14	12
10	12		16	16	14	12
12	16		14	12	Not Recommended	

ADDITIONAL SAFETY RULES

DO NOT let comfort or familiarity with product (gained from repeated use) replace strict adherence to miter saw safety rules. If you use this tool unsafely or incorrectly, you can suffer serious personal injury.

1. Wear eye protection.
2. Keep hands out of path of saw blade. Avoid contact with any coasting blade. It can still cause severe injury.
3. Do not operate saw without guards in place, Check blade guard for proper closing before each use. Do not operate saw if blade guard does not move freely and close instantly. Never clamp or tie the blade guard into the open position.
4. Do not perform any operation freehand. The workpiece must be secured firmly against the turn base and guide fence with a vise during all operations. Never use your hand to secure the workpiece.
5. Never reach around saw blades.

6. Turn off tool and wait the saw blade to stop before moving workpiece or changing settings.
7. Unplug tool before changing blade or servicing.
8. Always secure all moving portions before carrying the tool.
9. Do not use the tool in presence of flammable liquids or gases.
10. Check the blade carefully for cracks or damage before operation. Replace cracked or damaged blade immediately. Gum and wood pitch hardened on blades slows saw and increase potential for kickback. Keep blade clean by first removing it from tool, then cleaning it with gum and pitch remover, hot water or kerosene. Never use gasoline to clean blade.
11. Use only flanges specified for this tool.
12. Be careful not to damage the arbor, flanges (especially the installing surface) or bolt. Damage to these parts could result in blade breakage.
13. Make sure that the turn base is properly secured so it will not move during operation. Use the holes in the base to fasten the saw to a stable work platform or bench. NEVER use tool where operator position would be awkward.
14. For you safety, remove the chips, small pieces, etc. from the table top before operation.
15. Avoid cutting nails. Inspect for and remove all nails from the workpiece before operation.
16. Make sure the shaft lock is released before the switch is turned on.
17. Be sure that the blade does not contact the turn base in the lowest position.
18. Hold the handle firmly. Be aware that the saw moves up or down slightly during start-up and stopping.
19. Make sure the blade is not contacting the workpiece before the switch is turned on.
20. Before using the tool on an actual workpiece, let it run for a while. Watch for vibration or wobbling that could indicate poor installation or a poorly balanced blade.
21. Wait until the blade attains full speed before cutting.
22. Stop operation immediately if you notice anything abnormal.
23. Do not attempt to lock the trigger in the on position.
24. Be alert at all times, especially during repetitive, monotonous operations. Do not be lulled into a false sense of security. Blades are extremely unforgiving.
25. Always use accessories recommended in this manual. Use of improper accessories such as abrasive wheels may cause an injury.
26. NEVER hold workpiece on right side of blade with left hand or vice versa. This is called cross-armed cutting and exposes user to risk of SERIOUS PERSONAL INJURY as shown in the figure. ALWAYS use vise to secure workpiece.

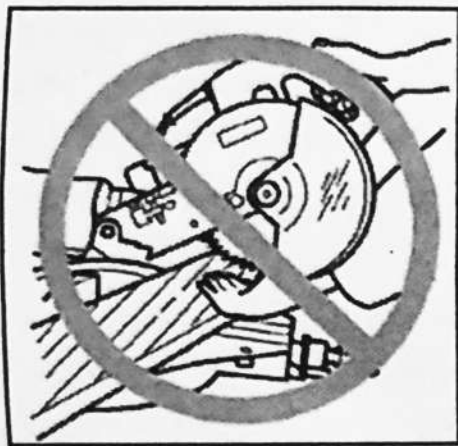

27. Do not abuse cord. Never yank cord to disconnect it from the receptacle. Keep cord away from heat, oil, water and sharp objects.
28. NEVER stack workpieces on the table top to speed cutting operations. Cut only one piece at a time.
29. Some material contains chemicals which may be toxic. Take caution to prevent dust inhalation and skin contact. Follow material supplier safety data.

SAVE THESE INSTRUCTIONS

WARNING:

MISUSE or failure to follow the safety rules stated in this instruction manual may cause serious personal injury.

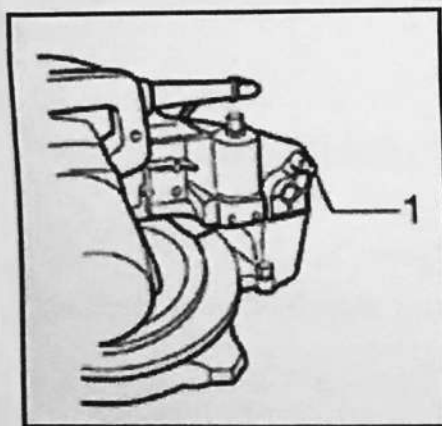

1. Stopper pin

Bench mounting

When the tool is shipped, the handle is locked in the lowered position by stopper pin. Release the stopper pin by lowering the handle slightly and pulling the stopper pin.

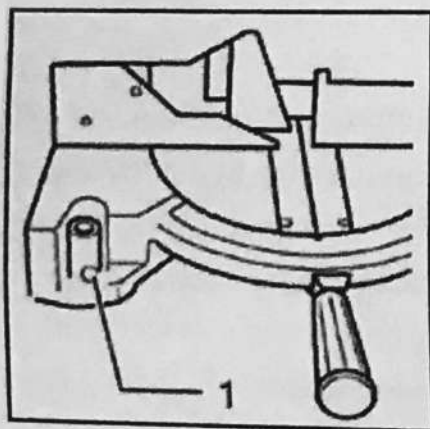

1. Bolt

This tool should be bolted with two bolts to a level and stable surface using the bolt holes provided in the tool's base. This will help prevent tipping and possible injury.

FUNCTIONAL DESCRIPTION

CAUTION

> Always be sure that the tool is switched off and unplugged before adjusting or checking function on the tool.

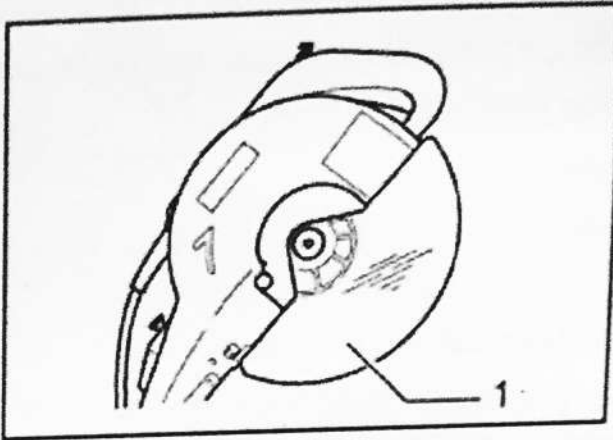

1. Blade guard

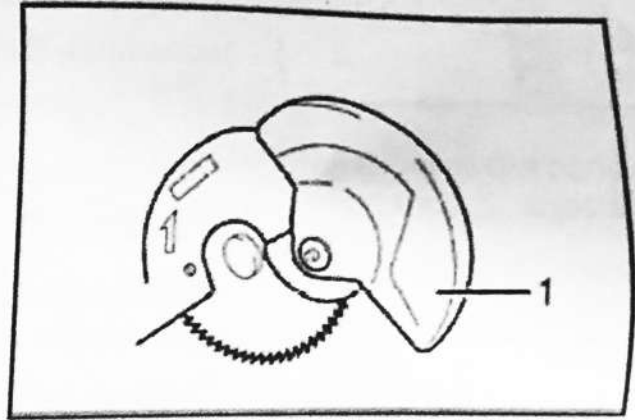

1. Blade guard

Blade guard

When lowering the handle, the blade guard rises automatically. The guard is spring loaded so it returns to its original position when the cut is completed and the handle is raised. NEVER DEFEAT OR REMOVE THE BLADE GUARD OR THE SPRING WHICH ATTACHES TO THE GUARD.

In the interest of your personal safety, always maintain the blade guard in good condition. Any irregular operation of the blade guard should be corrected immediately. Check to assure spring loaded return action of guard. NEVER USE THE TOOL IF THE BLADE GUARD OR SPRING ARE DAMAGED. FAULTY OR REMOVED. DOING SO IS HIGHLY DANGEROUS AND CAN CAUSE SERIOUS PERSONAL INJURY.

If the see-through blade guard becomes dirty, or sawdust adheres to it in such a way that the blade is no longer easily visible, unplug the saw and clean the guard carefully with a damp cloth. Do not use solvents or any petroleum-based cleaners on the plastic guard.

If the blade guard is especially dirty and vision through the guard is impaired, use the supplied socket wrench to loosen the hex bolt holding the center cover. Loosen the hex bolt by turning it counterclockwise and raise the blade guard and center cover. With the blade guard so positioned, cleaning can be more completely and efficiently accomplished. When cleaning is complete, reverse procedure above and secure bolt. Do not remove spring holding blade guard. If guard becomes discolored through age or UV light exposure, contact a service center for a new guard. DO NOT DEFEAT OR REMOVE GUARD.

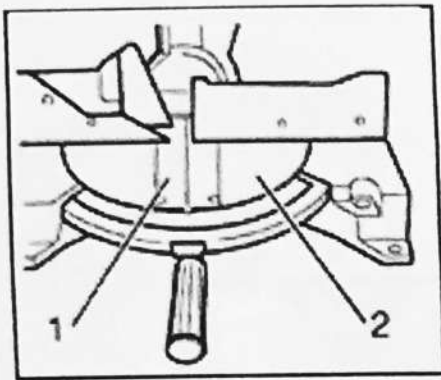

1. Kerf board 2. Turn base

Kerf board

This tool is provided with the kerf board in the turn base to minimize tearing on the exit side of a cut. If the kerf groove has not yet been cut in the kerf board by the factory, you should cut the groove before actually using the tool to cut a workpiece. Switch on the tool and lower the blade gently to cut a groove in the kerf board.

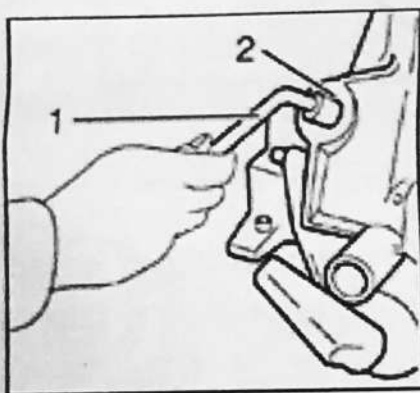

1. Socket wrench
2. Adjusting bolt

Maintaining maximum cutting capacity

This tool is factory adjusted to provide the maximum cutting capacity for a 255mm(10") saw blade.

When installing a new blade, always check the lower limit position of the blade and if necessary, adjust it as follows: First, unplug the tool. Lower the handle completely. Use the socket wrench to turn the adjusting bolt until the periphery of the blade extends slightly below the top surface of the turn base at the point where the front face of the guide fence meets the top surface of the turn base.

With the tool unplugged, rotate the blade by hand while holding the handle all the way down to be sure that the blade does not contact any part of the lower base. Re-adjust slightly if necessary.

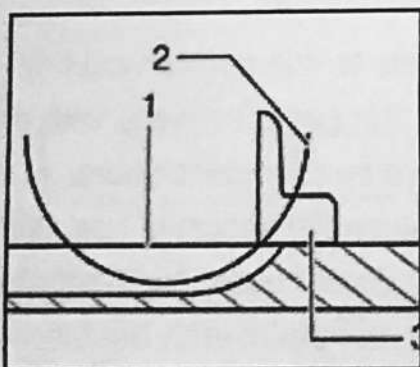

1. Top surface of turn base
2. Periphery of blade
3. Guide fence

CAUTION:

-After installing a new blade, always be sure that the blade does not contact any part of the lower base when the handle is lowered completely. Always do this with the tool unplugged.

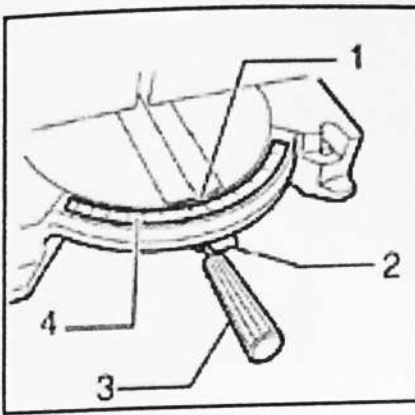

- 1. Pointer
- 2. Lock lever
- 3. Grip
- 4. Miter scale

Adjusting the miter angle

Loosen the grip by turning counterclockwise. Turn the turn base while pressing down the lock lever. When you have moved the grip to the position where the points to the desired angle on the miter scale, securely tighten the grip clockwise.

CAUTION

- > When turning the turn base, be sure to raise the handle fully.
- > After changing the miter angle, always secure the turn base by tightening the grip firmly.

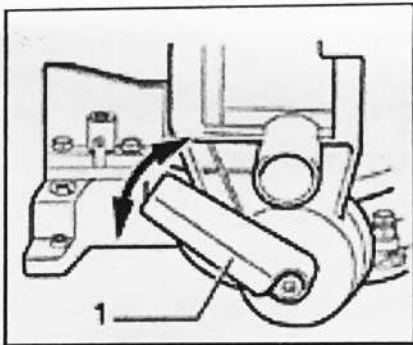

- 1. Lever

Adjusting the bevel angle

To adjust the bevel angle, loosen the lever at the rear of the tool counterclockwise

Push the handle to the left to tilt the saw blade until the pointer points to the desired angle on the bevel scale. Then tighten the lever clockwise firmly to secure the arm.

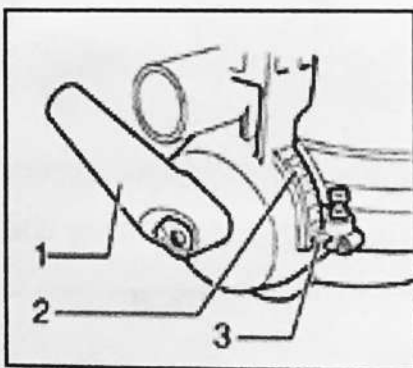

- 1. Lever
- 2. Bevel scale
- 3. Pointer

CAUTION

- When tilting the saw blade, be sure to raise the handle fully.
- After changing the bevel angle, always secure the arm by tightening the lever clockwise.

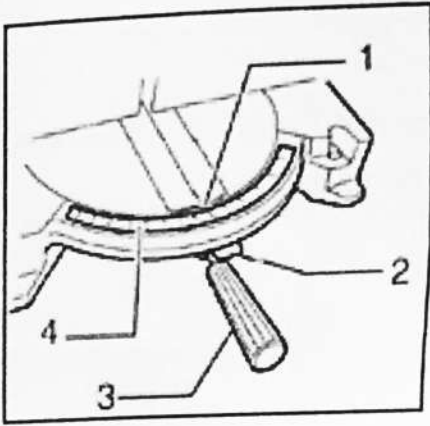

1. Pointer 2. Lock lever
3. Grip 4. Miter scale

Adjusting the miter angle

Loosen the grip by turning counterclockwise. Turn the turn base while pressing down the lock lever. When you have moved the grip to the position where the pointer points to the desired angle on the miter scale, securely tighten the grip clockwise.

CAUTION

- > When turning the turn base, be sure to raise the handle fully.
- > After changing the miter angle, always secure the turn base by tightening the grip firmly.

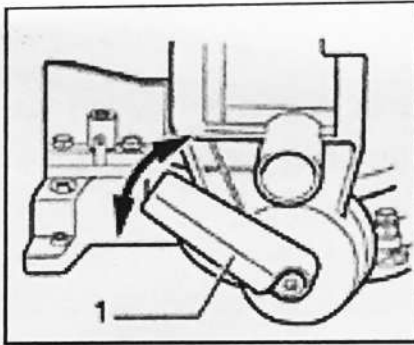

1. Lever

Adjusting the bevel angle

To adjust the bevel angle, loosen the lever at the rear of the tool counterclockwise

Push the handle to the left to tilt the saw blade until the pointer points to the desired angle on the bevel scale. Then tighten the lever clockwise firmly to secure the arm.

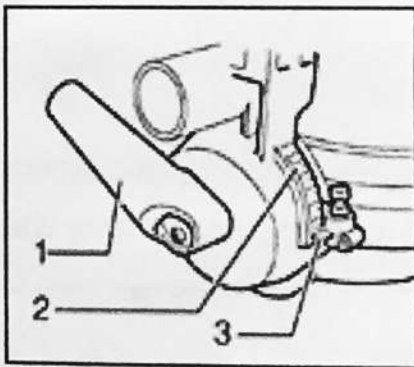

1. Lever 2. Bevel scale
3. Pointer

CAUTION

- When tilting the saw blade, be sure to raise the handle fully.
- After changing the bevel angle, always secure the arm by tightening the lever clockwise.

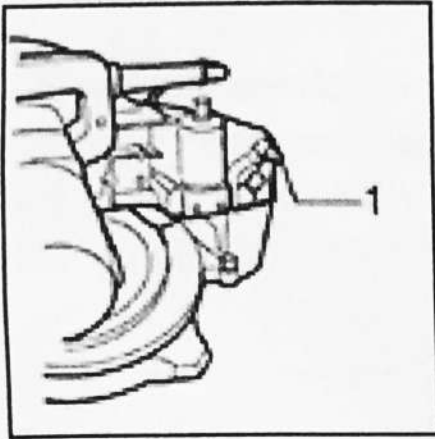

1. Stopper pin

ASSEMBLY

CAUTION:

-Always be sure that the tool is switched off unplugged before carrying out any work on the tool.

Installing or removing saw blade

CAUTION

-Always be sure that the tool is switched off and unplugged before installing or removing the blade.

-Use only the socket wrench provided to install or remove the blade. Failure to do so may result in overtightening or insufficient tightening of the hex bolt. This could cause an injury.

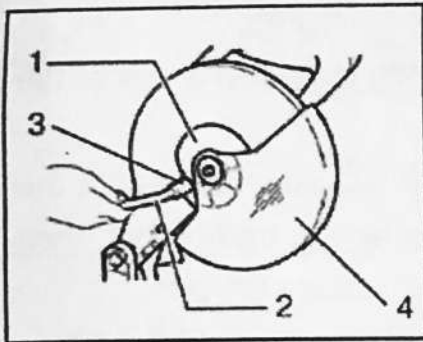

1. Center cover 2,Socket wrench
3. Hex bolt 4. Blade guard

To remove the blade, use the socket wrench to loosen the hex bolt holding the center cover by turning it counterclockwise. Raise the blade guard and center cover.

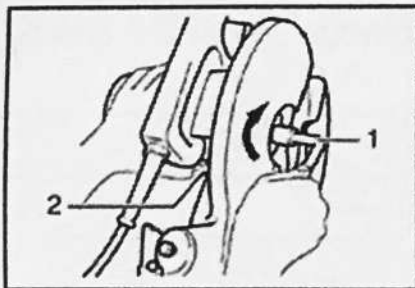

1. Socket wrench 2. Shaft lock

Press the shaft lock to lock the spindle and use the socket wrench to loosen the hex bolt clockwise. Then remove the hex bolt, outer flange and blade.

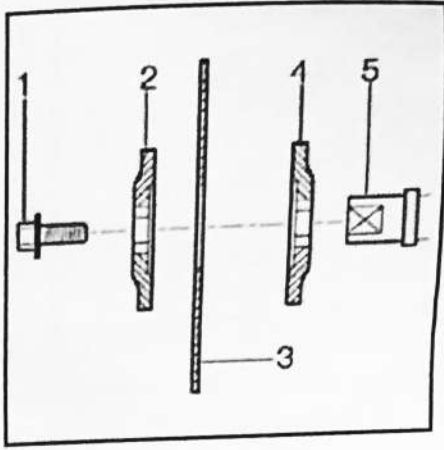

1. Hex bolt 2. Outer flange
3. Saw blade 4. Inner flange
5. Spindle

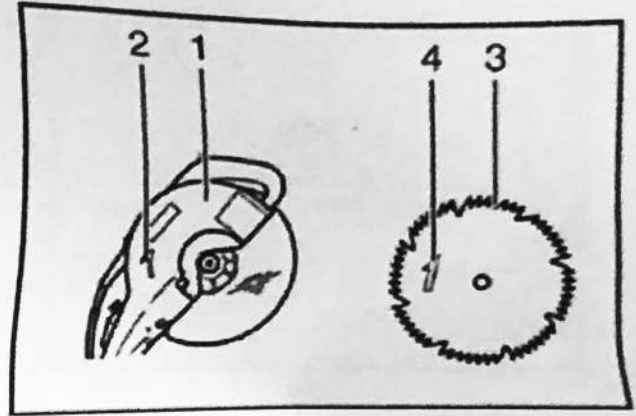

1. Blade case 2. Arrow
3. Saw Blade 4. Arrow

To install the blade, mount it carefully onto the spindle, making sure that the direction of the arrow on the surface of the blade matches the direction of the arrow on the blade case. Install the outer flange and hex bolt (left-handed) securely counter-clockwise while pressing the shaft lock.

Return the blade guard and center cover to its original position. Then tighten the hex bolt clockwise to secure the center cover. Lower the handle to make sure that the blade guard moves properly. Make sure shaft lock has released spindle before making cut.

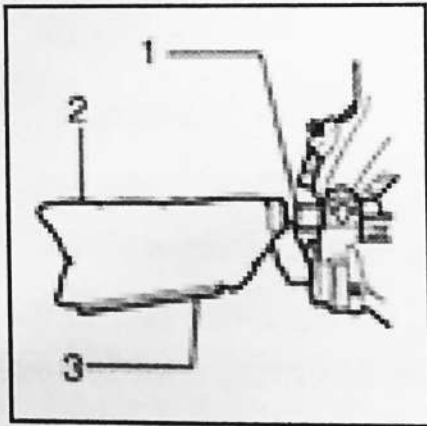

1. Dust nozzle 2. Dust bag
3. Fastener

Dust bag

The use of the dust bag makes cutting operations clean and dust collection easy. To attach the dust bag, fit it onto the dust nozzle.

When the dust bag is about half full, remove the dust bag from the tool and pull the fastener out. Empty the dust bag of its contents, tapping it lightly so as to remove particles adhering to the insides which might hamper further collection.

NOTE:

If you connect vacuum cleaner to your saw, more efficient and cleaner operations can be performed.

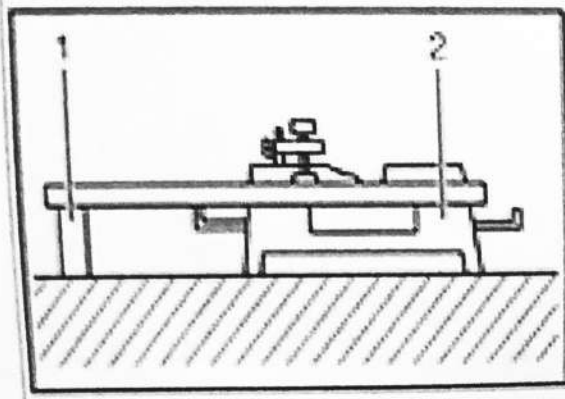

1. Support 2. Turn base

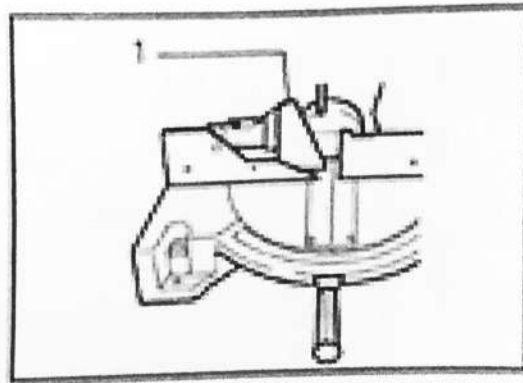

1. Sub-fence

Securing workpiece

WARNING:

> It is extremely important to always secure the workpiece properly and tightly with the vise. Failure to do so can cause the tool to be damaged and/or the workpiece to be destroyed. PERSONAL INJURY MAY ALSO RESULT. Also, after a cutting operation, DO NOT raise the blade until the blade has come to a complete stop.

CAUTION:

> When cutting long workpieces, use supports that are as high as the top surface level of the turn base. Do not rely solely on the vertical vise and/or horizontal vise to secure the workpiece.

Thin material tends to sag. Supports workpiece over its entire length to avoid blade pinch and possible KICKBACK.

Sub-fence

This tool is equipped with the sub-fence. It should be positioned as shown in the figure.

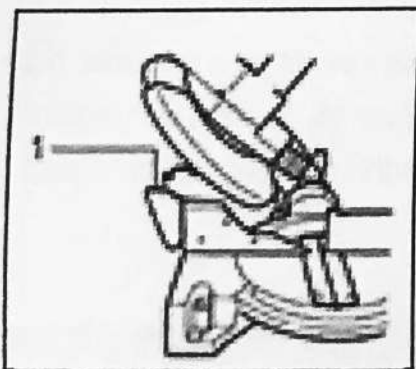

1. Sub-fence

CAUTION:

When performing left bevel cuts, flip the fence over to the left position as shown in the figure. Otherwise, it will contact the blade or a part of the tool, causing possible serious injury to the operator.

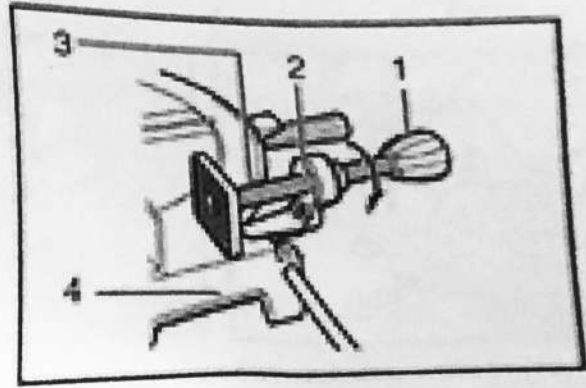
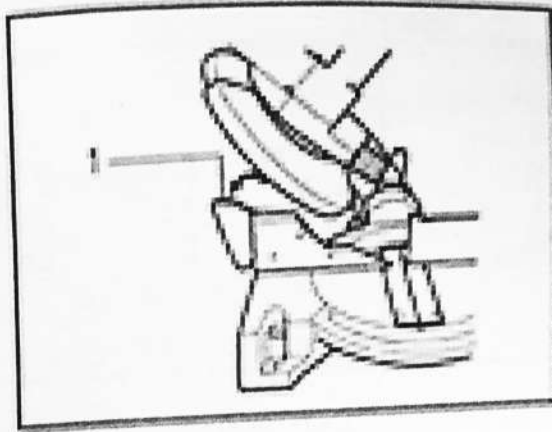

Horizontal vise (optional accessory)

The horizontal vise can be installed on either the left or right side of the base. When performing 15° or greater miter cuts, install the horizontal vise on the side opposite the direction in which the turn base is to be turned. By turning the vise knob clockwise, the screw remains secured. To grip the workpiece, turn the vise knob gently clockwise until the projection reaches its topmost position, then fasten securely. If the vise knob back counter clockwise until the screw is released, before tuning again gently clockwise.

The maximum width of the workpiece which can be secured by the horizontal vise is 130mm(5-1/8").

CAUTION:

> Grip the workpiece only when the projection is at the topmost position. Failure to do so may result in insufficient securing of the workpiece, This could cause the workpiece to be thrown, cause damage to the blade or cause the loss of control, which can result in PERSONAL INJURY.

CAUTION:

> Before use, be sure to release the handle from the lowered position by pulling the stopper pin.

> Make sure the blade is not contacting the workpiece, etc. before the switch is turned on.

> Do not apply excessive pressure on the handle when cutting. Too much force may result in overload of the motor and/or decreased cutting efficiency. Push down handle with only as much force as is necessary for smooth cutting and without significant decrease in blade speed.

> Gently press down the handle to perform the cut. If the handle is pressed down with force or if lateral force is applied, the blade will vibrate and leave a mark (saw mark) in the workpiece and the precision of the cut will be impaired.

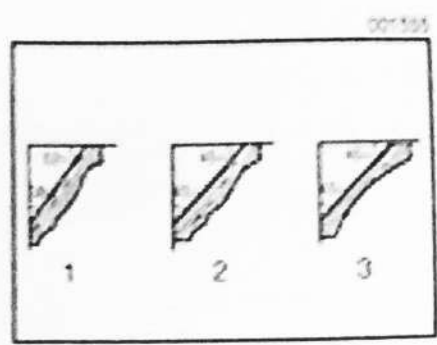
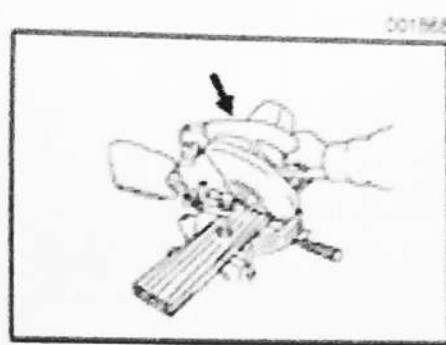

1. 52/38°type crown molding
2. 45°type crown molding
3. 45°type cove molding

1. Press cutting

Secure the workpiece with the vise. Switch on the tool without the blade making any contact and wait until the blade attains full speed before lowering. Then gently lower the handle to the fully lowered position to cut the workpiece. When the cut is completed, switch off the tool and WAIT UNTIL THE BLADE HAS COME TO A COMPLETE STOP before returning the blade to its fully elevated position.

2. Miter cutting

Refer to the previously covered "Adjusting the miter angle".

3. Bevel cut

Loosen the lever and tilt the saw blade to set the bevel angle (Refer to the previously covered "Adjusting the bevel angle"). Be sure to retighten the lever firmly to secure the selected bevel angle safely. Secure the workpiece with a vise. Switch on the tool without the blade making any contact and wait until the blade attains fully lowered position while applying pressure in parallel with the blade. When the cut is completed, switch off the tool and WAIT UNTIL THE BLADE HAS COME TO A COMPLETE STOP before returning the blade to its fully elevated position.

CAUTION:

- > Always be sure that the blade will move down to bevel direction during a bevel cut. Keep hands out of path of saw blade.
- > During a bevel cut, it may create a condition whereby the piece cut off will come to rest against the side of the blade. If the blade is raised while the blade is still rotating, this piece may be caught by the blade, causing fragments to be scattered which is dangerous. The blade should be raised ONLY after the blade has come to a complete stop.
- > When pressing the handle down, apply pressure parallel to the blade. If the pressure is not parallel to the blade during a cut, the angle of the blade might be shifted and the precision of the cut will be impaired.

4. Compound cutting

Compound cutting is the process in which a bevel angle is made at the same time in which a miter angle is being cut on a workpiece. Compound cutting can be performed at angle shown in the table.

Bevel angle Miter angle
 45° Left and Right 0-45°

When performing compound cutting, refer to "Press cutting", "Miter cutting" and "Bevel cut" explanations.

Bevel angle	Miter angle
45°	Left and Right 0-45°

5. Cutting crown and cove moldings

Crown and cove moldings can be cut on a compound miter saw with the moldings laid flat on the turn base.

There are two common types of crown moldings and one type of cove molding; 52/38° wall angle crown molding, 45° wall angle cove molding. See illustrations.

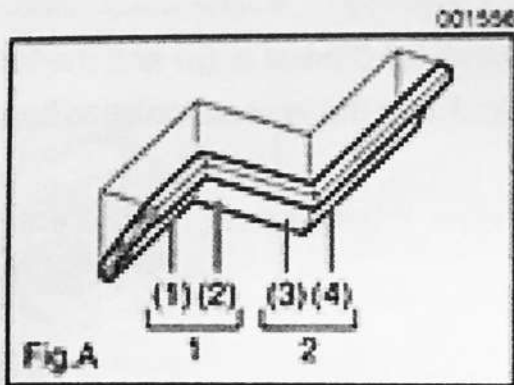

1. Inside corner 2. Outside corner

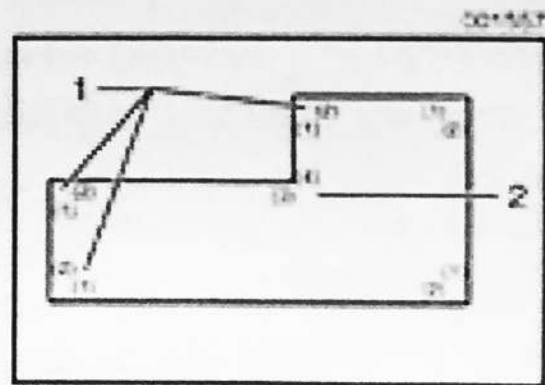

1. Inside corner 2. Outside corner

There are crown and cove molding joints which are made to fit "inside" 90° corners ((1) and (2)) in Fig. A) and "Outside" 90° corners ((3) and (4)) in Fig. A).

Measuring

Measure the wall length and adjust workpiece on table to cut wall contact edge to desired length. Always make sure that cut workpiece length at the back of the workpiece is the same as wall length. Adjust cut length for angle of cut. Always use several pieces for test cuts to check the saw angles.

When cutting crown and cove moldings, set the bevel angle and miter angle as indicated in the table(A) and position the moldings on the top surface of the saw base as indicated in the table(B).

ACCESSORIES

CAUTION:

> These accessories or attachments are recommended for use with your BAW tool specified in this manual. The use of any other accessories or attachments might present a risk of injury to persons. Only use accessory or attachment for its stated purpose.

If you need any assistance for more details regarding these accessories, ask your local BAW service center.

> Steel & Carbide-tipped saw blades

Miter saw blades	For smooth and precise cutting in various materials
Combination	General purpose blade for fast and smooth rip, crosscuts and miters.
Crosscutting	For smoother cross grain cuts. Slices cleanly against the grain.
Fine cross cuts	For sand-free cuts cleanly against the grain.
Non-ferrous metals miter saw blades	For miter in aluminum, copper, brass, tubing, and other nonferrous metals.

> Vise assembly (Horizontal vise)

> Socket wrench 13

> Dust bag

> Triangular rule

> Lock-off button (2 pcs.)

Fig	Part Name	Qty	Fig	Part Name	Qty
1	Fixed pin ϕ 25*16	1	51	Hex Screw M8*20	2
2	Aluminum Side Cover	1	52	Screw M6*8	2
3	Safety Guard	1	53	Connecting Rod	1
4	Flat Washer ϕ 5	6	54	Side piece	1
5	Tapping Screw M5*10	5	55	Locknut M6	1
6	Tapping Screw M6*10	2	56	Base Pin ϕ 18	1
7	Center Cover	1	57	Rivet	2
8	Tapping Screw M6*15	1	58	Locating Plate	1
9	Hex Screw M8*16	1	59	Steel Pointer	1
10	Outer Flanger	1	60	Tapping Screw M4*8	7
11	Blade	1	61	Plastic Plate Cover	1
12	Torsional Spring ψ 25* ψ 2*8	1	62	Hex Screw M10*33	1
13	Inner Flange	1	63	Tapping Screw M4*8	1
14	Bearing Cover	1	64	Pointer	1
15	Spingdle	1	65	Plate	1
16	Ball Bearing 6202RS/SYBS	1	66	Hex Screw M8*25	4
17	Front Cover	1	67	Spring Washer ψ 8	6
18	Woodruff Key 4* ψ 13	1	68	Flat Washer ψ 8	6
19	Gear	1	69	Crossbar	1
20	Retainer Ring ψ 17	1	70	Base	1
21	Needle Bearing 1210	1	71	Flat Washer ψ 10	1
22	Hex Screw M8*75	1	72	Locknut M10	1
23	Hex Nut M8(White)	3	73	Spring Steel	1
24	Aluminum blade Cover	1	74	Locking Button	1
25	Selflocking Spring	1	75	Casting iron	1
26	Selflocking	1	76	Hex Screw M8*30	2
27	Ball Bearing 6202RZ/BAW	1	77	Flat Washer ψ 8	1
28	Rotor	1	78	Handle	1
29	Ball Bearing 6202RZ/BAW	1	79	Handle cover	1
30	Ring	1	80	Tapping Screw ST5*20	1
31	Tapping Screw ST5*60	2	81	Additional Handle	2
32	Stator	1	82	Plastic pad	1
33	Plastic Housing	1	83	Switch	1
34	Brusher Holder	2	84	Switch Spring ψ 7*0.5*21	1
35	Carbon Brush 6.5*13.5*18	2	85	Cross Screw M5*35	1
36	Brush Cap	2	86	Tapping Screw ST5*35	2
37	Rear Cover	1	87	Tapping Screw ST4*14	2
38	Tapping Screw ST4*14	2	88	Upper Handle	1
39	Spring Pad ψ 5	4	89	Platen	1
40	Tapping Scew M5*55	4	90	Down Handle	1
41	Tapping Scew M4*12	2	91	Cord Guard	1
42	Plastic Locking Wrench	1	92	Cord 2*0.75*25	1

43	Locking Nut M10*50	1		93	Tapping Screw M5*10	2
44	Stopper Pin	1		94	Baffle	3
45	O Ring $\psi 8 \times \psi 1$	1		95	Screw Rod M16*170	1
46	Big Spring	1		96	Plastic Guide	1
47	Pressure Spring Base	1		97	Locing Nut	1
48	Locking Pin $\psi 8 \times 23$	1		98	Hand Wheel	1
49	Locknut M16	1		99	Socket Wrench M8	1
50	Aluminum Stand	1		100	Dust Bag	1

