

USER MANUAL

Currency Counter

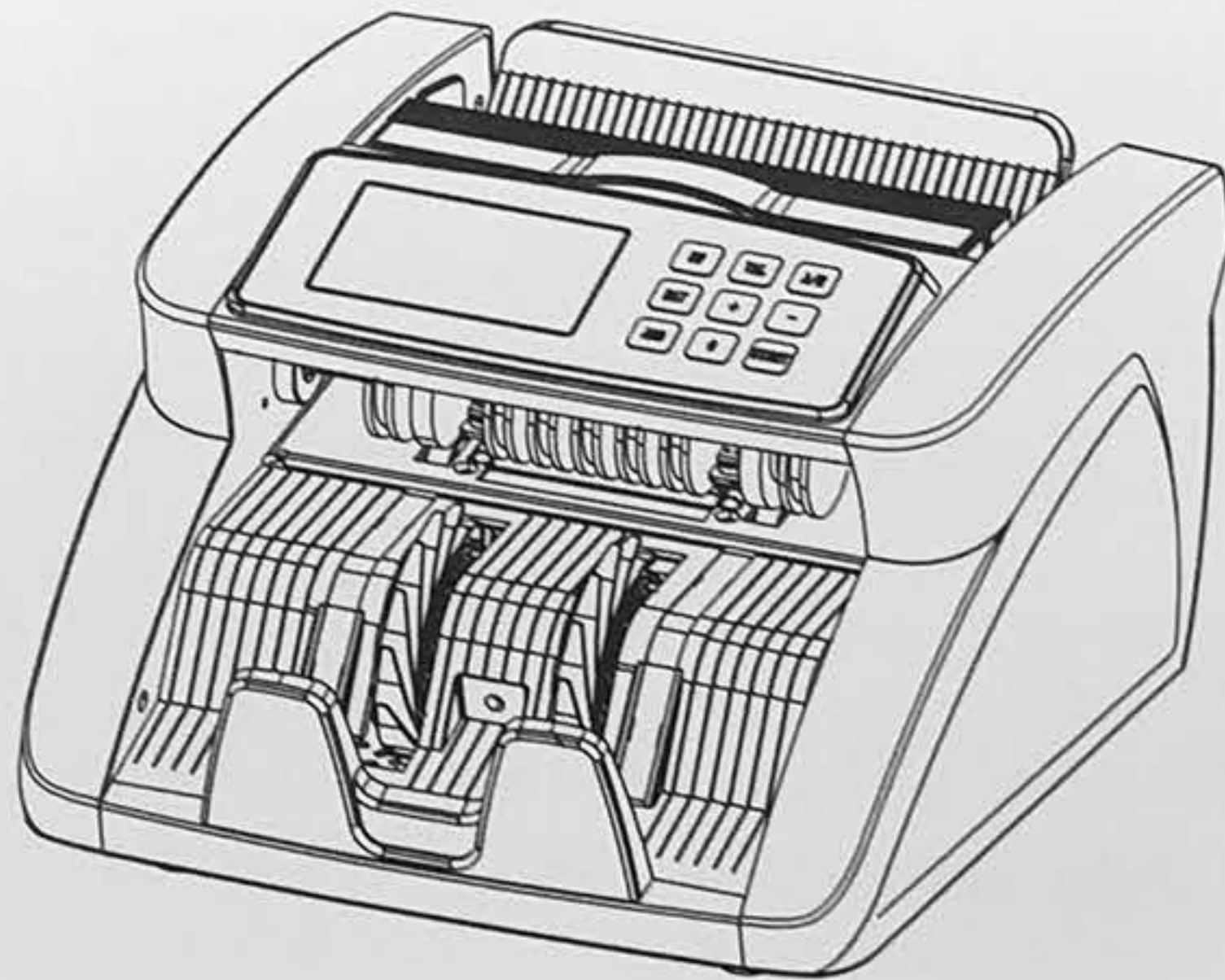

3904

Thank you for purchasing our bill counter with value counting. This guide will provide you with safety information, instructions for optimal use, and proper care and maintenance for your product. Please read this manual carefully before operation.

CONTENTS

SAFETY INSTRUCTIONS.....	2
BOX CONTENTS & PRODUCT VIEW.....	3
SPECIFICATION.....	4
CONTROL PANEL.....	4
MODES & FUNCTION.....	5
OPERATION	5
THICKNESS SETTING.....	6
CLEANING AND MAINTENANCE.....	7
SELF-EXAMINATION CODE.....	7
TROUBLESHOOTING.....	8

SAFETY INSTRUCTIONS

When using this machine follow these basic safety precautions to reduce risk of fire, electric shock injury.

WARNING

1. Only use the power cord that comes with the machine. Using a different power cord may result in electric shock, fire, or cause serious damage to the machine. Plug the power cord into a proper grounded wall outlet.
2. Do not use the machine if the power cord is damaged. This may result in electric shock, fire, or other hazards.
3. Do not place the machine in an area where it may be exposed to water or other liquids.
4. To reduce the risk of electric shock, do not take apart the machine. When service or repair is needed, bring to a qualified service repair technician.
5. When unplugging the power plug, grip the plug to pull it out. Pulling the cord may result in electric shock, fire, or damage to the machine.
6. Do not place objects on the power cord and do not bend it excessively. This may result in electric shock, fire, or other hazards.

CAUTION

1. Before dusting the machine with a brush, unplug the machine from the wall. Do not use liquid or aerosol cleaners on the machine.
2. Do not use the machine in areas with high temperature or high humidity. This may result in the machine not working properly.
3. When not using the machine for long periods of time, unplug the power cord from the outlet.

BOX CONTENTS & PRODUCT VIEW

The retail box contains the following items:

Money Counter
User's Guide

Power Cord
External monitor

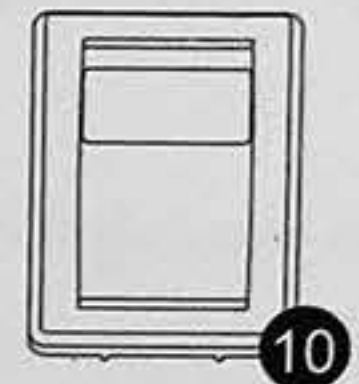
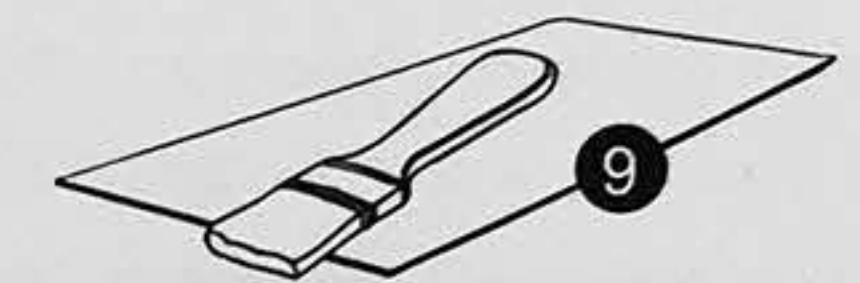
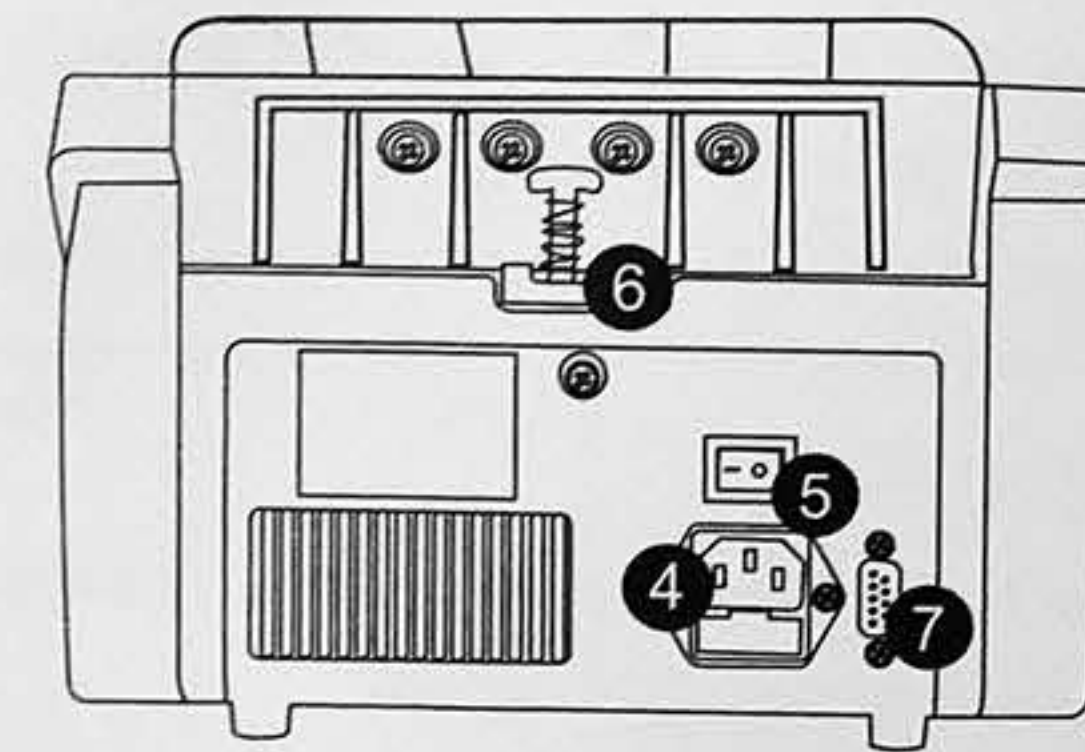
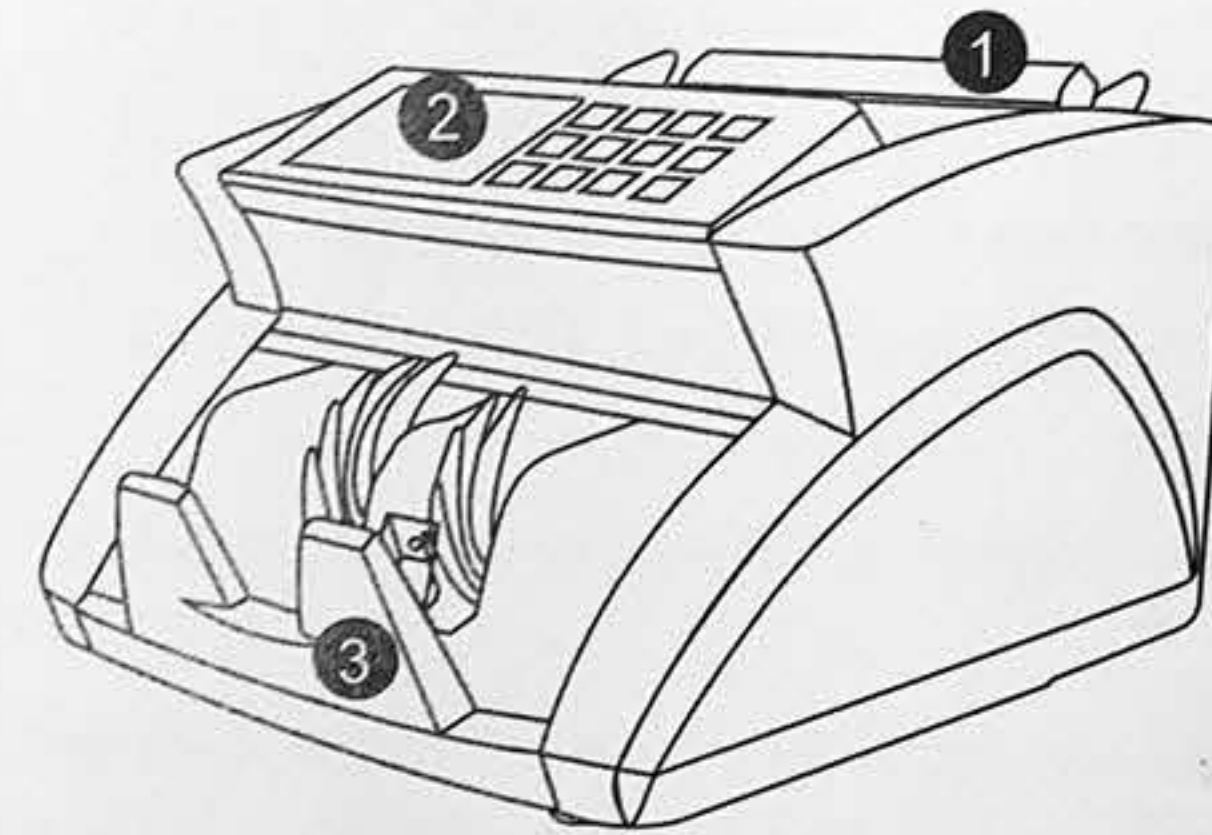

- 1 Hopper with note guides
- 2 Control panel (display / buttons)
- 3 Stacker
- 4 Power socket
- 5 Power switch

- 6 Adjustment knob
- 7 RJ232 port for external display
- 8 Power cord
- 9 User's Guide
- 10 External monitor

SPECIFICATION

Counting Speed	≥900pcs/min
Hopper Capacity	130 notes
Stacker Capacity	130 notes
Power	AC 198-242V 50Hz
Power Consumption	100W
Dimensions	290mmx250mmx175mm
Net Weight	4.3kg

CONTROL PANEL

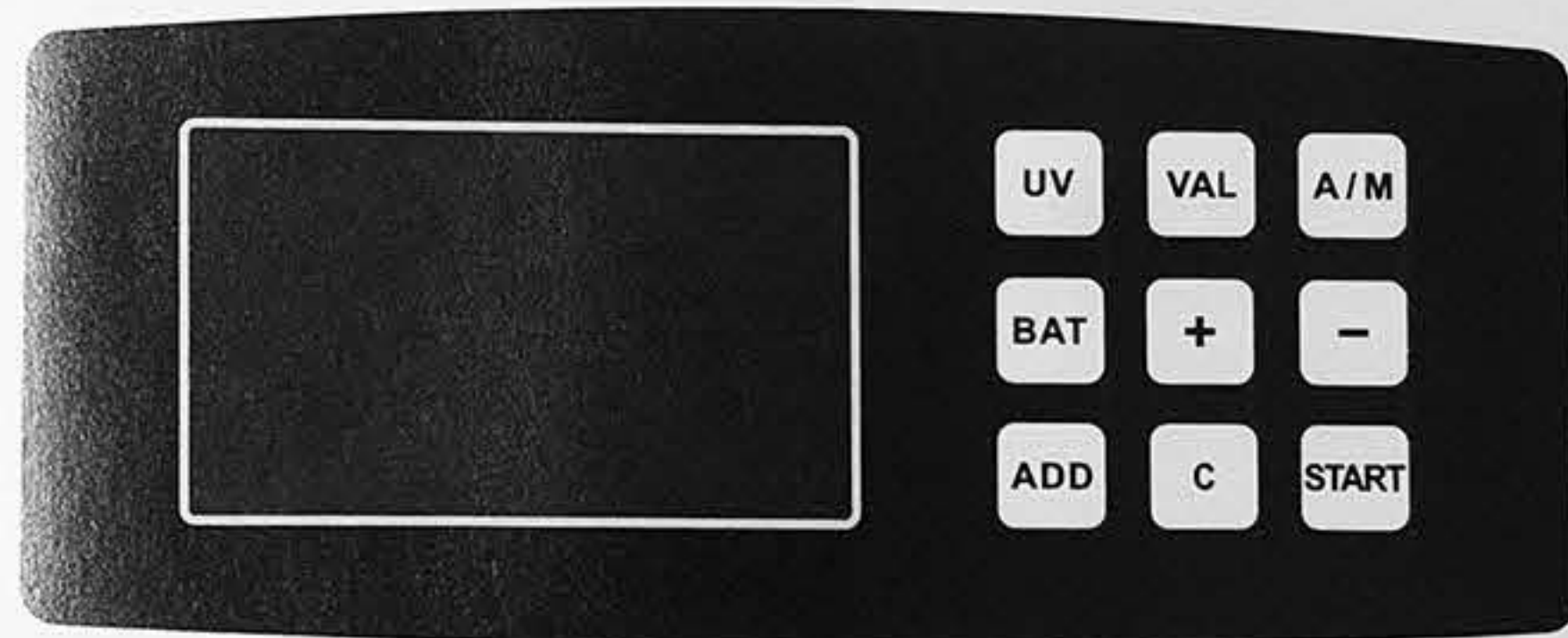

UV	Turn on/off UV(Ultraviolet) counterfeit detection.
VAL	Turn on the manual value function.
A/M	Change start mode between manual and automatic.
BAT	Turn on/off BAT function.
ADD	Turn on/off ADD function.
C	Clear the counting result.
+	Increase the number of the SET menu.
-	Decrease the number of the SET menu.
START	Start counting manual.

MODES & FUNCTION

Ultraviolet counterfeit detection (UV)

Counterfeit bills often use white or bleached paper, which will glow under ultraviolet light. When the UV sensor finds a counterfeit bill, the machine will stop counting to allow removal of the counterfeit bill and display the error code on the display. Press UV to turn on/off ultraviolet counterfeit detection.

Manual value counting (VAL)

Keep pressing VALUE button for 3 seconds to turn on/off the manual value counting function. By this function, use “+” & “-” to choose denomination manually. For example, when you choose 2000 INR and count 100 notes, the display will show total value 200000 INR. Please note that when you choose 2000 INR, you must count 2000 INR. If you put other denomination such as 500 INR or 100 INR etc, this machine will memorize it as 2000 INR.

Under this function, the user can turn on ADD function to count many different denominations and add the total value of different denominations together.

Batch function (BAT)

Press BAT to turn on/off batch function. The BAT mode counts bills in batches. The preset batch number is 100. Use the keypad to enter a batch number between 1 and 999.

Adding function (ADD)

The ADD mode displays the cumulative total of all bills counted. Press ADD to turn on/off adding function.

OPERATION

1. Attach power cord to back of the machine, plug into a outlet, and turn power switch on.
The unit will conduct an automatic self-diagnostic test to ensure accurate counts. After five seconds of the counting wheels the screen will display a “0” .If there is a problem, the preset display will show an error code.
2. Select bill counting settings.
Before counting, select counting settings that related to your counting needs. (See FUNCTION – LOCATED ON PAGE 5)

3. Place bills into the hopper to begin counting.

Avoid counting wet, dirty or spoiled banknotes.

- A) Check for foreign matter mixed with the bills for example paperchips, rubber bands, clips and dust.
- B) Straighten the folds or corners of the bills before insertion.
- C) Put the banknotes on the hopper as shown below.
- D) Adjust the note guides according to the longest bill in the stack.

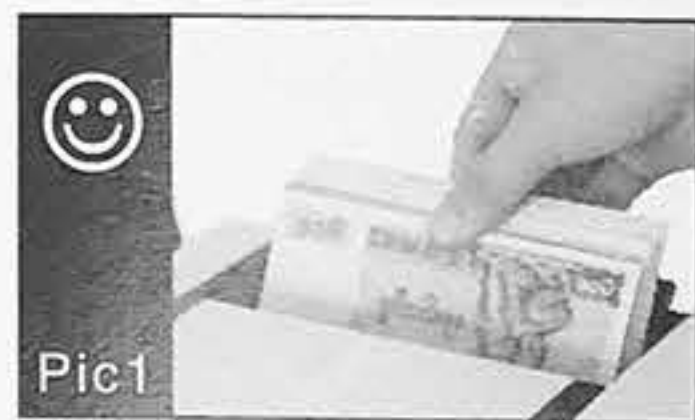

THICKNESS SETTING

Thickness setting must always be adjusted to achieve a proper and smooth feeding of banknotes. The thickness is adjusted with the thickness adjustment knob found on the back of the machine.

- A) If the banknotes run too hard or too slow: Turn the adjustment knob clockwise to increase the gap between the feed rollers.
- B) If the machine stops frequently and displays
Turn the adjustment knob slightly counter-clockwise to decrease the gap between the feed rollers.

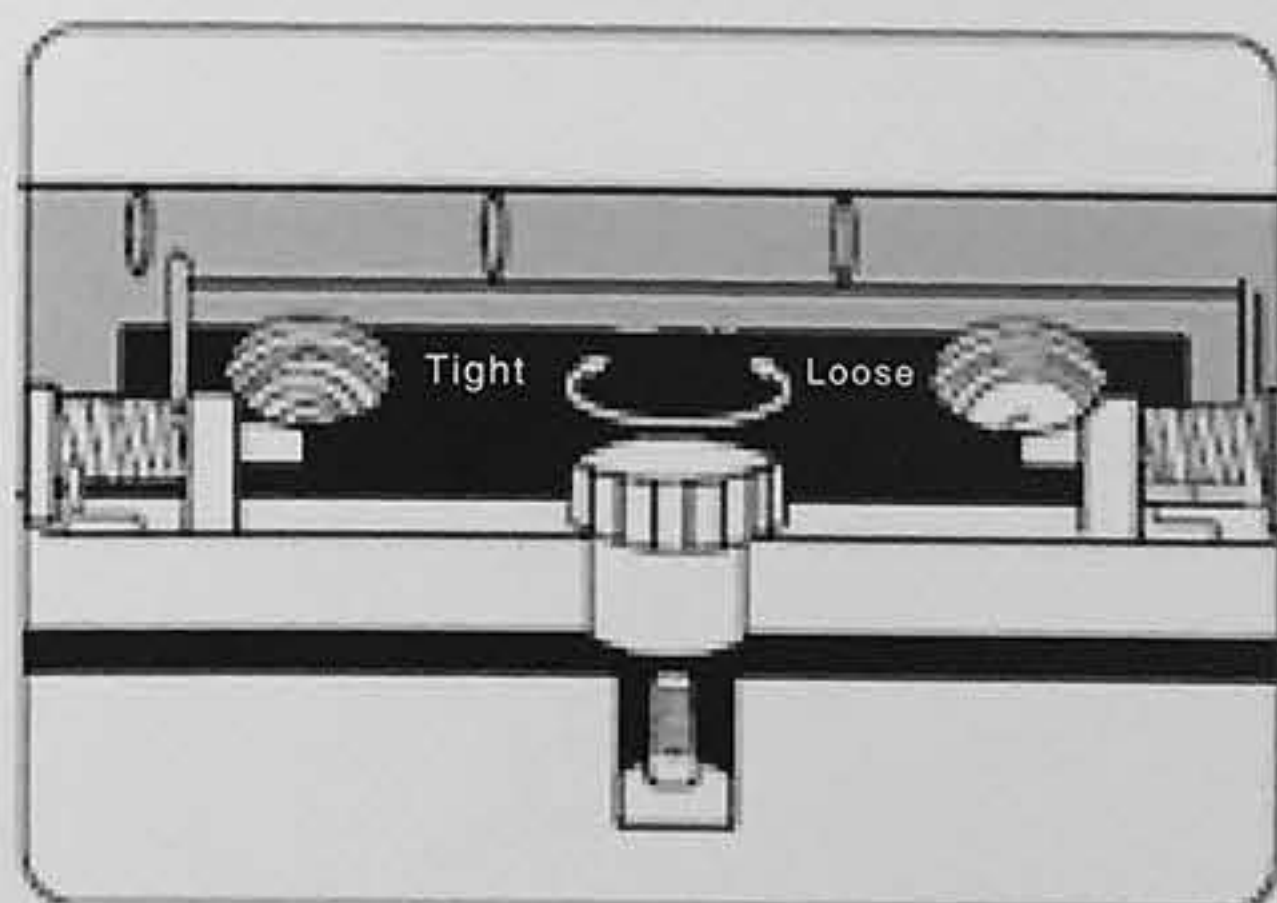

CLEANING AND MAINTENANCE

Before doing any cleaning, turn the power switch off.

It's very important to clean all the sensors in the machine with a soft brush and cloth to avoid any paper particles or dust from sticking to the light transmitter or the light-receiver sensors after a period's of application.

It's necessary to clean the inside of the machine occasionally.

SELF-EXAMINATION CODE

When you turn on the machine and the machine show you the following codes. Self-examination function is activated and the code means there are some problem with the machine. Refer to the chart below to solve the error.

Error Code	Cause	Solutions
CE01	The left counting sensor is broken or dirty	Clean or replace sensor
CE02	The right counting sensor is broken or dirty	Clean or replace sensor
CE03	The speed sensor is dirty or loosen or there is problem in the main motor	Clean or replace sensor Or replace the motor
CE04	The feeding sensor is broken or dirty	Clean or replace sensor
CE05	The receiving sensor is broken or dirty	Clean or replace sensor
CE10	The working environment light is too strong	Lower the working environment light
	UV sensor is broken	Clean or replace sensor

TROUBLESHOOTING

Before asking for maintenance service please check the machine as follows:

No power

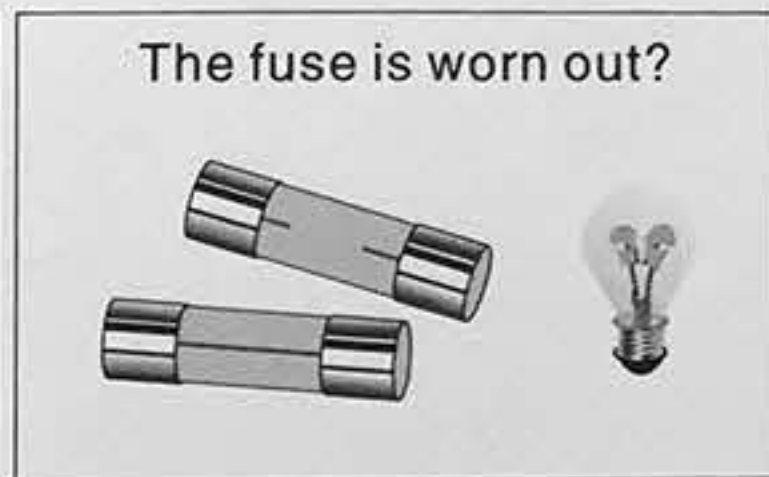
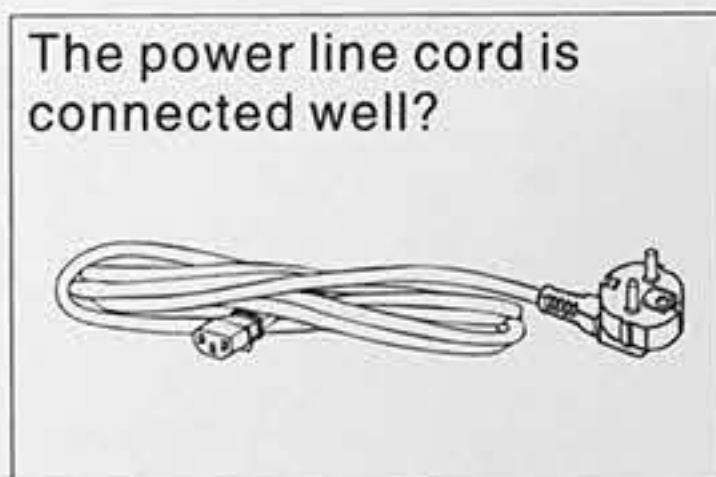

Power is on, but the unit is not working.



Wrong counting



Wrong detecting

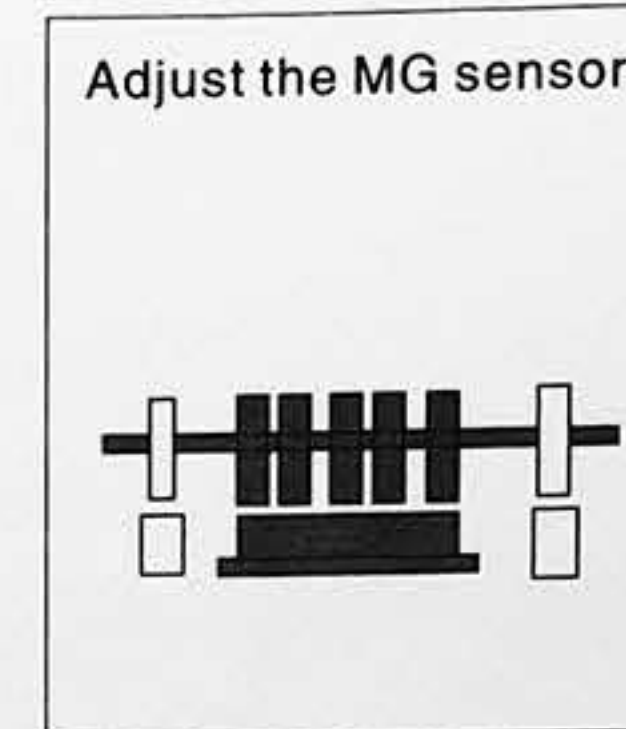
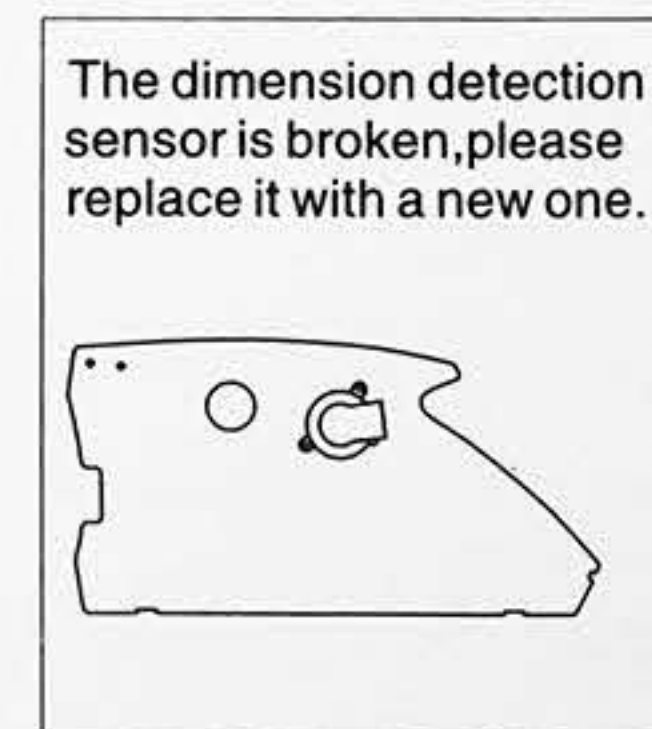

DELI GROUP CO., LTD.

301 Xuxiake Ave. Ninghai County
Ningbo 315600 China Made in China
info@nbdeli.com www.deliworld.com



Keep for future use

Version: 1.0

Date:November-2021