

cecotec

POWER BLACK TITANIUM 1200 INOX

Batidora de vaso/Jug blender.



Manual de instrucciones
Instruction manual
Manuel d'instructions
Bedienungsanleitung
Manuale di istruzioni
Manual de instruções
Handleiding
Instrukcja obsługi
Návod k použití

INDEX

1. Parts and components	30
2. Before use	30
3. Product assembly	30
4. Operation	30
5. Cleaning and maintenance	31
6. Technical specifications	31
7. Disposal of old electrical appliances	32
8. Technical support and warranty	32

SAFETY INSTRUCTIONS

Read these instructions thoroughly before using the appliance. Keep this instruction manual for future reference or new users. Make sure that the mains voltage matches the voltage stated on the rating label of the appliance and that the wall outlet is grounded.

This product is designed only for household use. Do not use outdoors.

Check the power cord regularly for visible damage. If the cord is damaged, it must be replaced by the official Technical Support Service of Cecotec in order to avoid any type of danger.

The blades inside the product are very sharp, handle them carefully to avoid any possible cut.

Take extreme precaution during cleaning, maintenance or while emptying the jug.

Do not pour hot liquids inside the product while it is operating as it could be ejected out causing burns.

Never leave the appliance unattended while in use.

Always turn off and disconnect the appliance from the power supply before assembling, disassembling, cleaning it or if it is not going to be used for a long period of time. Pull from the plug, not the cord, to disconnect it from the outlet.

Do not immerse the cord, plug, or any non-removable part of the appliance in water or any other liquid, nor expose the electrical connections to water. Make sure your hands are dry before handling the plug or switching on the appliance.

Do not use accessories not provided or suggested by Cecotec, as these could cause damage to the product or result in risk.

Do not twist, bend, strain, or damage the power cord in any way. Protect it from sharp edges and heat sources. Do not let it touch hot surfaces. Do not let the cord hang over the edge of the working surface or countertop.

Do not use the product outdoors, close to electric plates, gas, flames or inside an oven.

Extreme caution must be taken when moving appliances containing hot liquids or foodstuffs.

Always turn the appliance off and disconnect it from the power supply before changing accessories or approaching moving elements.

Do not expose the device to extreme temperatures.

Do not introduce any utensil inside the product during operation in order to reduce risk of injuries to persons or damage to the product. A scraper may be used while the product is paused.

Make sure to keep the measuring lid in its position when blending hot liquids or ingredients.

Do not use the product if its blade is curved or damaged.

Do not operate the appliance empty.

Make sure the accessory that is going to be used is properly assembled before operating the device.

Do not overfill the jar.

When blending fruits, remove hard bones before introducing them in the device.

Always operate the product with the cover in place.

The appliance is not intended to be used by children under the

age of 8. It can be used by children over the age of 8, as long as they are given continuous supervision.

This product can be used by children and persons with reduced physical, sensory or mental capabilities or lack of experience and knowledge, as long as they have been given supervision or instruction concerning the use of the appliance in a safe way and understand the hazards involved.

Children shall not play with the appliance. Close supervision is necessary when the appliance is being used by or near children.

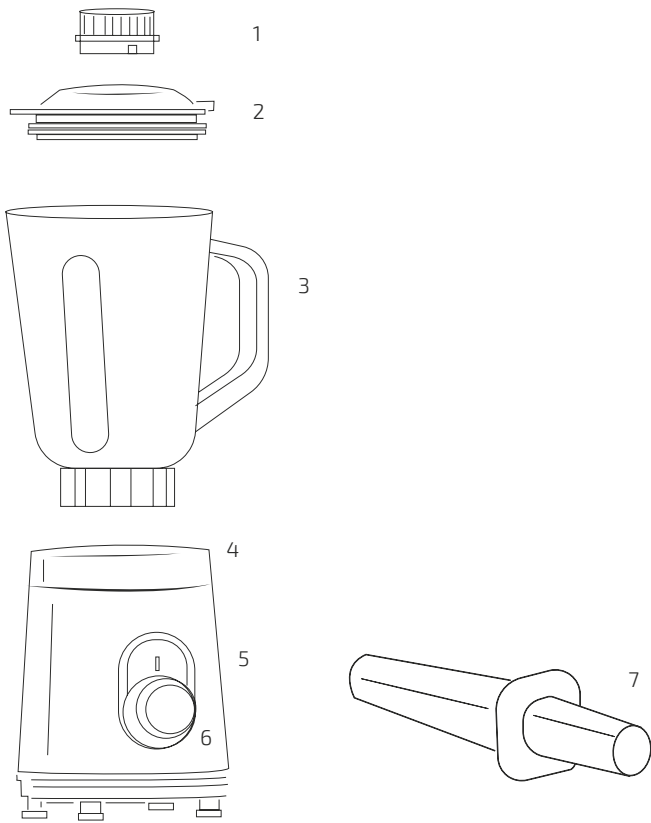

Fig./Img./Abb./Rys./Obr. 1

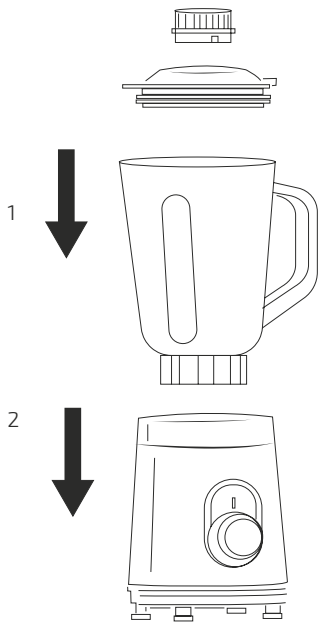

Fig./Img./Abb./Rys./Obr. 2

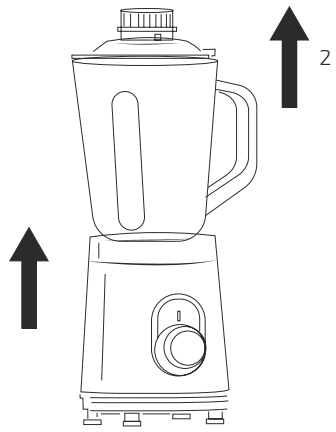

Fig./Img./Abb./Rys./Obr.3

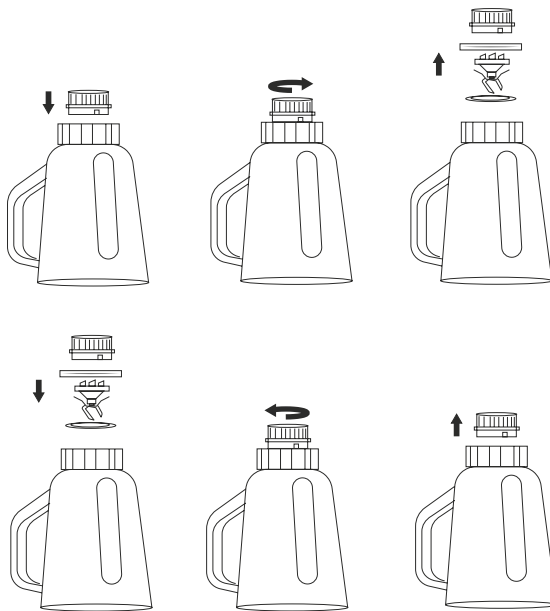

Fig./Img./Abb./Rys./Obr.4

1. PARTS AND COMPONENTS

Fig. 1.

1. Measuring cup
2. Lid
3. Glass blending jar
4. Motor base
5. LED
6. Speed knob
7. Pusher

2. BEFORE USE

Take the product out of the box and remove all packaging materials, stickers, etc. Make sure all parts and accessories are included, and check that they do not show any signs of damage. If there are any, contact the official Technical Support Service of Cecotec. Place the appliance on a flat, stable and dry surface.

3. PRODUCT ASSEMBLY

To assemble the blending jar, introduce in the motor base.

Fig. 2.

To remove it from the main body, pull from it upwards.

Fig. 3.

4. OPERATION

Turn the knob clockwise to set the desired blending speed according to the food to be blended. 1 is the minimum speed and 5 is the maximum speed.

Turn the knob anticlockwise to active Pulse mode (P). The device will operate at top speed.

To blend larger pieces of food, use the pusher. Use it only when operating the device at low speed and introduce it down the measuring cup hole, without taking the lid.

Note:

Do not exceed the Max. mark on the jar.

When preparing juices, use 2 parts of soft fruit and 3 parts of water (carrots and apples are considered hard fruits).

Do not operate the device at top speed for more than 1 minute.

5. CLEANING AND MAINTENANCE

Cleaning

Always turn the power knob to the "0" position, turn the switch off and unplug the appliance after each use and before cleaning.

Use water to clean the jug. Do not use chemical or harsh abrasive cleaning agents.

Use a dry, soft cloth to clean the motor base. Do not clean this part with a wet cloth.

The only dishwasher-safe part is the jar.

The blades inside the product are very sharp, handle them carefully to avoid any possible cut.

Using the measuring cup, turn the joint system joining the blades and the base of the jar counterclockwise. Once it has been loosened, carefully remove the blades.

Repeat the process in reverse to assemble the device (turning clockwise).

Fig. 4

Maintenance

If the product does not operate normally, produces uncommon noises or shakes more than it normally does, stop using the product and contact the Technical Support Service of Cecotec for reparation. Do not carry out maintenance tasks yourself.

Storage

After cleaning the device, make sure it is thoroughly dried before storing it.

After using the product, store it in a dry, safe place.

Avoid direct exposure to sun light.

Make sure it is stored in a place out of the reach of children.

6. TECHNICAL SPECIFICATIONS

Model: Power Black Titanium 1200 Inox

Product reference: 04158

1200 W, 220-240 V, 50/60 Hz

Jar capacity: 1.5 L

Made in China | Designed in Spain

7. DISPOSAL OF OLD ELECTRICAL APPLIANCES



The European directive 2012/19/EU on Waste Electrical and Electronic Equipment (WEEE), specifies that old household electrical appliances must not be disposed of with the normal unsorted municipal waste. Old appliances must be collected separately, in order to optimise the recovery and recycling of the materials they contain and reduce the impact on human health and the environment.

The crossed out "wheeled bin" symbol on the product reminds you of your obligation to dispose of the appliance correctly.

If the product has a built-in battery or uses batteries, they should be removed from the appliance and disposed of appropriately.

Consumers must contact their local authorities or retailer for information concerning the correct disposal of old appliances and/or their batteries.

8. TECHNICAL SUPPORT AND WARRANTY

This product is under warranty for 2 years from the date of purchase, as long as the proof of purchase is submitted, the product is in perfect physical condition, and it has been given proper use, as explained in this instruction manual.

The warranty will not cover the following situations:

The product has been used for purposes other than those intended for it, misused, beaten, exposed to moisture, immersed in liquid or corrosive substances, as well as any other fault attributable to the customer.

The product has been disassembled, modified, or repaired by persons, not authorised by the official Technical Support Service of Cecotec.

Faults deriving from the normal wear and tear of its parts, due to use.

The warranty service covers every manufacturing defects of your appliance for 2 years, based on current legislation, except consumable parts.

In the event of misuse, the warranty will not apply.

If at any moment you detect any problem with your product or have any doubt, do not hesitate to contact Cecotec Technical Support Service at +34 963 210 728.

www.cecotec.es

Grupo Cecotec Innovaciones S. L.
C/de la Pinadeta s/n, 46930
Quart de Poblet, Valencia, Spain

EA01201209