

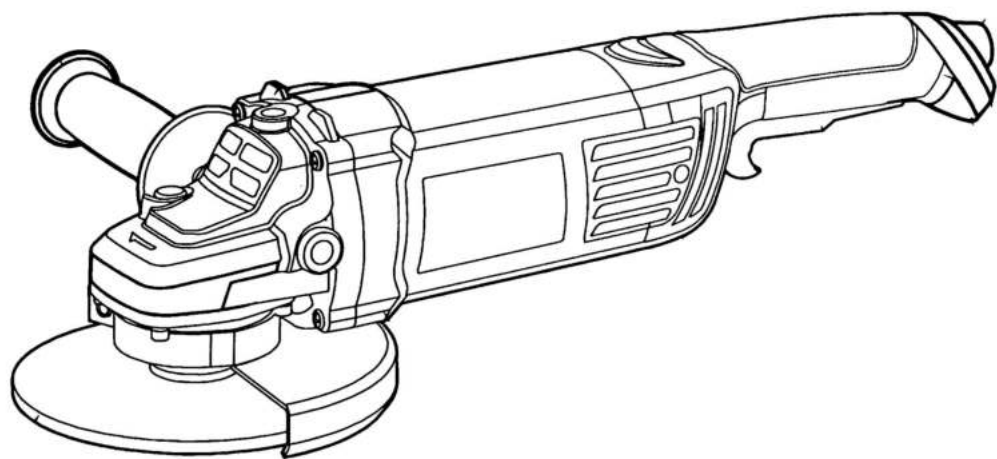

User Manual

Angle Grinder DL6374



1 MAIN PARTS DESCRIPTION

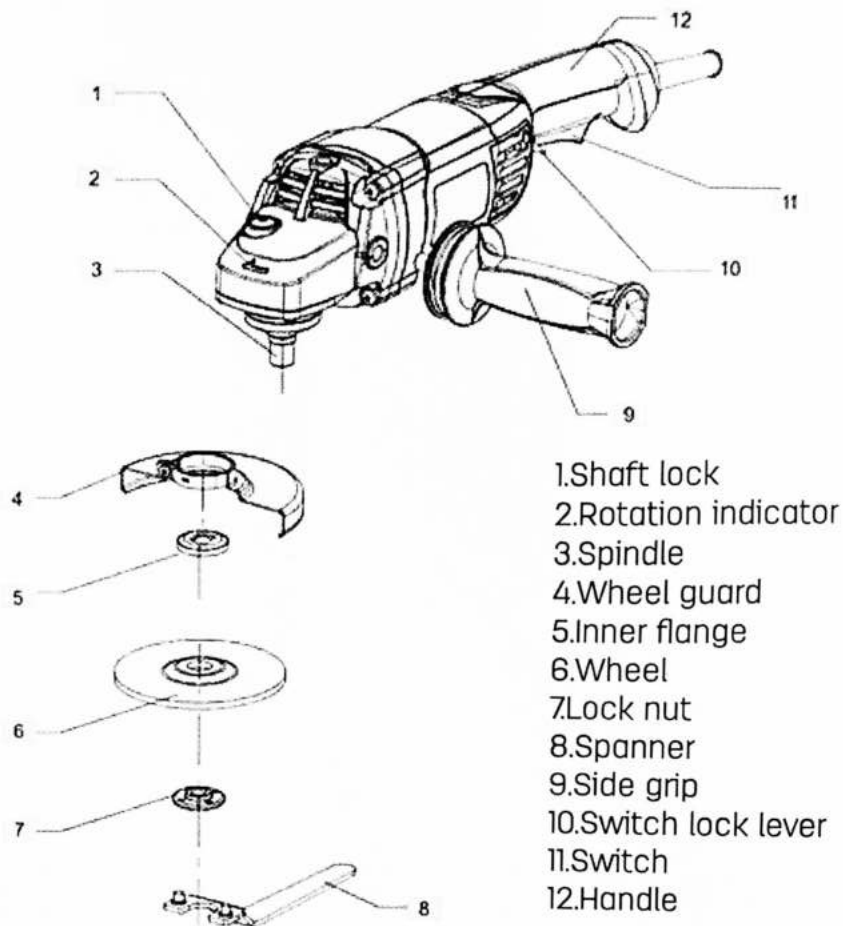

Model	DL6374
Disc diameter	150mm
Spindle thread	M14
No load speed(RPM)	8200rpm
Rated input power	1600W
Net weight	3.8kg

WARNING: Read all instructions .Failure to follow all instructions listed below may result in electric shock, fire and/or serious personal injury.

SAVE THESE INSTRUCTIONS

The term "power tool" in all of the warnings listed below refers to your mains operated (corded) power tool or battery operated (cordless) power tool

1 WORK AREA SAFETY

- 1.1 Keep work area clean and well lit. Cluttered or dark areas invite accidents.
- 1.2 Do not operate power tools in explosive atmospheres, such as in the presence of flammable liquids, gases or dust. Power tools create sparks which may ignite the dust or fumes.
- 1.3 Keep children and bystanders away while operating a power tool. Distractions can cause you to lose control.

2 Electrical safety

- 2.1 Power tool plugs must match the outlet. Never modify the plug in any way. Do not use any adapter plugs with earthed (grounded) power tools. Unmodified plugs and matching outlets will reduce risk of electric shock.
- 2.2 Avoid body contact with earthed or grounded surfaces, such as pipes, radiators, ranges and refrigerators. There is an increased risk of electric shock if your body is earthed or grounded.
- 2.3 Do not expose power tools to rain or wet conditions. Water entering a power tool will increase the risk of electric shock.
- 2.4 Do not abuse the cord. Never use the cord for carrying, pulling or unplugging the power tool. Keep cord away from heat, oil, sharp edges or moving parts. Damaged or entangled cords increase the risk of electric shock.
- 2.5 When operating a power tool outdoors, use an extension cord suitable for outdoor use. Use of a cord suitable for outdoor use reduces the risk of electric shock.

3 Personal safety

- 3.1 Stay alert, watch what you are doing and use common sense when operating a power tool. Do not use a power tool while you are tired or under the influence of drugs, alcohol or medication. A moment of inattention while operating power tools may result in serious personal injury.
- 3.2 Use personal protective equipment. Always wear eye protection. Protective equipment such as dust mask, non-skid safety shoes, hard hat, or hearing protection used for appropriate conditions will reduce personal injuries.
- 3.3 Prevent unintentional starting. Ensure the switch is in the off-position before connecting to power source and/or battery pack, picking up or carrying the tool. Carrying power tools with your finger on the switch or energizing power tools that have the switch on invites accidents.
- 3.4 Remove any adjusting key or wrench before turning the power tool on. A wrench or a key left attached to a rotating part of the power tool may result in personal injury.
- 3.5 Do not overreach. Keep proper footing and balance at all times. This enables better control of the power tool in unexpected situations.
- 3.6 Dress properly. Do not wear loose clothing or jewellery. Keep your hair, clothing and gloves away from moving parts. Loose clothes, jewellery or long hair can be caught in moving parts.
- 3.7 If devices are provided for the connection of dust extraction and collection facilities, ensure these are connected and properly used. Use of dust collection can reduce dust-related hazards.

4 Power tool use and care

- 4.1 Do not force the power tool. Use the correct power tool for your application. The correct power tool will do the job better and safer at the rate for which it was designed.
- 4.2 Do not use the power tool if the switch does not turn it on and off. Any power tool that cannot be controlled with the switch is dangerous and must be repaired.
- 4.3 Disconnect the plug from the power source and/or the battery pack from the power tool before making any adjustments, changing accessories, or storing power tools. Such preventive safety measures reduce the risk of starting the power tool accidentally.

4.4 Store idle power tools out of the reach of children and do not allow persons unfamiliar with the power tool or these instructions to operate the power tool. Power tools are dangerous in the hands of untrained users.

4.5 Maintain power tools. Check for misalignment or binding of moving parts, breakage of parts and any other condition that may affect the power tool's operation. If damaged, have the power tool repaired before use. Many accidents are caused by poorly maintained power tools.

4.6 Keep cutting tools sharp and clean. Properly maintained cutting tools with sharp cutting edges are less likely to bind and are easier to control.

4.7 Use the power tool, accessories and tool bits etc. in accordance with these instructions, taking into account the working conditions and the work to be performed. Use of the power tool for operations different from those intended could result in a hazardous situation.

5 Battery tool use and care

1.Recharge only with the charger specified by the manufacturer. A charger that is suitable for one type of battery pack may create a risk of fire when used with another battery pack.

2.Use power tools only with specifically designated battery packs. Use of any other battery packs may create a risk of injury and fire.

3.When battery pack is not in use, keep it away from other metal objects, like paper clips, coins, keys, nails, screws or other small metal objects that can make a connection from one terminal to another Shorting the battery terminals together may cause burns or a fire.

4.Under abusive conditions, liquid may be ejected from the battery; avoid contact if contact accidentally occurs, flush with water. If liquid contacts eyes, additionally seek medical help. Liquid ejected from the battery may cause irritation or burns.

6.Service

1.Have your power tool serviced by a qualified repair person using only identical replacement parts. This will ensure that the safety of the power tool is maintained.

ADDITIONAL SAFETY INSTRUCTIONS FOR GRINDING AND CUTTING-OFF OPERATIONS

Safety Warnings Specific for Grinding and Abrasive Cutting-Off Operations:

1.This power tool is intended to function as a grinder, sander, and wire brush or cut-off tool. Read all safety warnings, instructions, illustrations and specifications provided with this power tool. Failure to follow all instructions listed below may result in electric shock, fire and/or serious injury.

2.Operations such as polishing are not recommended to be performed with this power tool. Operations for which the power tool was not designed may create a hazard and cause personal injury.

3.Do not use accessories which are not specifically designed and recommended by the tool manufacturer. Just because the accessory can be attached to your power tool, it does not assure safe operation.

4.The rated speed of the accessory must be at least equal to the maximum speed marked on the power tool. Accessories running faster than their rated speed can break and fly apart.

5.The outside diameter and the thickness of your accessory must be within the capacity rating of your power tool. Incorrectly sized accessories cannot be adequately guarded or controlled.

6.The arbor size of wheels, flanges, backing pads or any other accessory must properly fit the spindle of the power tool. Accessories with arbor holes that do not match the mounting hardware of the power tool will run out of balance, vibrate excessively and may cause loss of control

7.Do not use a damaged accessory. Before each use inspect the accessory such as abrasive wheels for chips and cracks, backing pad for cracks, tear or excess wear, wire brush for

loose or cracked wires. If power tool or accessory is dropped, inspect for damage or install an undamaged accessory. After inspecting and installing an accessory, position yourself and bystanders away from the plane of the rotating accessory and run the power tool at maximum no-load speed for one minute. Damaged accessories will normally break apart during this test time.

8.Wear personal protective equipment. Depending on application, use face shield, safety goggles or safety glasses. As appropriate, wear dust mask, hearing protectors,

gloves and workshop apron capable of stopping small abrasive or workpiece fragments. The eye protection must be capable of stopping flying debris generated by various operations. The dust mask or respirator must be capable of filtering particles generated by your operation. Prolonged exposure to high intensity noise may cause hearing loss.

9. Keep bystanders a safe distance away from work area. Anyone entering the work area must wear personal protective equipment. Fragments of workpiece or of a broken accessory may fly away and cause injury beyond immediate area of operation.

10. Hold power tool by insulated gripping surfaces only, when performing an operation where the cutting accessory may contact hidden wiring or its own cord. Cutting accessory contacting a "live" wire may make exposed metal parts of the power tool "live" and shock the operator.

11. Position the cord clear of the spinning accessory. If you lose control, the cord may be cut or snagged and your hand or arm may be pulled into the spinning accessory.

12. Never lay the power tool down until the accessory has come to a complete stop. The spinning accessory may grab the surface and pull the power tool out of your control.

13. Do not run the power tool while carrying it at your side. Accidental contact with the spinning accessory could snag your clothing, pulling the accessory into your body.

14. Regularly clean the power tool's air vents. The motor's fan will draw the dust inside the housing and excessive accumulation of powdered metal may cause electrical hazards.

15. Do not operate the power tool near flammable materials. Sparks could ignite these materials.

16. Do not use accessories that require liquid coolants. Using water or other liquid coolants may result in electrocution or shock.

Kickback and Related Warnings

Kickback is a sudden reaction to a pinched or snagged rotating wheel, backing pad, brush or any other accessory. Pinching or snagging causes rapid stalling of the rotating accessory which in turn causes the uncontrolled power tool to be forced in the direction opposite of the accessory's rotation at the point of the binding.

For example, if an abrasive wheel is snagged or pinched by the workpiece, the edge of the wheel that is entering into the pinch point can dig into the surface of the material causing the wheel to climb out or kick out. The wheel may either jump toward or away from the operator, depending on direction of the wheel's movement at the point of pinching. Abrasive wheels may also break under these conditions.

Kickback is the result of power tool misuse and/or incorrect operating procedures or conditions and can be avoided by taking proper precautions as given below.

a. Maintain a firm grip on the power tool and position your body and arm to allow you to resist kickback forces. Always use auxiliary handle, if provided, for maximum control over kickback or torque reaction during start-up. The operator can control torque reactions or kickback forces, if proper precautions are taken.

b. Never place your hand near the rotating accessory. Accessory may kickback over your hand.

c. Do not position your body in the area where power tool will move if kickback occurs. Kickback will propel the tool in direction opposite to the wheel's movement at the point of snagging.

d. Use special care when working corners, sharp edges etc. Avoid bouncing and snagging the accessory. Corners, sharp edges or bouncing have a tendency to snag the rotating accessory and cause loss of control or kickback.

e. Do not attach a saw chain woodcarving blade or toothed saw blade. Such blades create frequent kickback and loss of control.

Safety Warnings Specific for Grinding and Abrasive Cutting-Off

Operations:

a. Use only wheel types that are recommended for your power tool and the specific guard designed for the selected wheel. Wheels for which the power tool was not designed cannot be adequately guarded and are unsafe.

b. The guard must be securely attached to the power tool and positioned for maximum safety, so the least amount of wheel is exposed towards the operator. The guard helps to protect operator from broken wheel fragments and accidental contact with wheel.

c. Wheels must be used only for recommended applications. For example: do not grind with the side of cut-off wheel. Abrasive cut-off

wheels are intended for peripheral grinding, side forces applied to these wheels may cause them to shatter.

d. Always use undamaged wheel flanges that are of correct size and shape for your selected wheel. Proper wheel flanges support the wheel thus reducing the possibility of wheel breakage. Flanges for cut-off wheels may be different from grinding wheel flanges.

e. Do not use worn down wheels from larger power tools. Wheel intended for large power tool is not suitable for the higher speed of a smaller tool and may burst.

Additional Safety Warnings Specific for Abrasive Cutting-Off Operations:

a. Do not "jam" the cut-off wheel or apply excessive pressure. Do not attempt to make an excessive depth of cut. Overstressing the wheel increases the loading and susceptibility to twisting or binding of the wheel in the cut and the possibility of kickback or wheel breakage.

b. Do not position your body in line with and behind the rotating wheel. When the wheel, at the point of operation, is moving away from your body, the possible kickback may propel the spinning wheel and the power tool directly at you.

c. When wheel is binding or when interrupting a cut for any reason, switch off the power tool and hold the power tool motionless until the wheel comes to a complete stop. Never attempt to remove the cut-off wheel from the cut while the wheel is in motion otherwise kickback may occur. Investigate and take corrective action to eliminate the cause of wheel binding.

d. Do not restart the cutting operation in the workpiece. Let the wheel reach full speed and carefully reenter the cut. The wheel may bind, walk up or kickback if the power tool is restarted in the workpiece.

e. Support panels or any oversized workpiece to minimize the risk of wheel pinching and kickback. Large workpieces tend to sag under their own weight. Supports must be placed under the workpiece near the line of cut and near the edge of the workpiece on both sides of the wheel.

f. Use extra caution when making a "pocket cut" into existing walls or other blind areas. The protruding wheel may cut gas or water pipes,

electrical wiring or objects that can cause kickback.

a. Do not use excessively oversized sanding disc paper. Follow manufacturer's recommendations, when selecting sanding paper. Larger sanding paper extending beyond the sanding pad presents a laceration hazard and may cause snagging, tearing of the disc or kickback.

Safety Warnings Specific for Wire Brushing Operations:

a. Be aware that wire bristles are thrown by the brush even during ordinary operation. Do not overstress the wires by applying excessive load to the brush. The wire bristles can easily penetrate light clothing and/or skin.

b. If the use of a guard is recommended for wire brushing, do not allow interference of the wire wheel or brush with the guard. Wire wheel or brush may expand in diameter due to work load and centrifugal forces.

Additional safety warnings:

17. When using depressed center grinding wheels, be sure to use only fiberglass-reinforced wheels.

18. Be careful not to damage the spindle, the flange (especially the installing surface) or the lock nut. Damage to these parts could result in wheel breakage.

19. Make sure the wheel is not contacting the workpiece before the switch is turned on.

20. Before using the tool on an actual workpiece, let it run for a while. Watch for vibration or wobbling that could indicate poor installation or a poorly balanced wheel.

21. Use the specified surface of the wheel to perform the grinding.

22. Watch out for flying sparks. Hold the tool so that sparks fly away from you and other persons or flammable materials.

17. When using depressed center grinding wheels, be sure to use only fiberglass-reinforced wheels.

18. Be careful not to damage the spindle, the flange (especially the installing surface) or the lock nut. Damage to these parts could result in wheel breakage.

19. Make sure the wheel is not contacting the workpiece before the switch is turned on.

20. Before using the tool on an actual workpiece, let it run for a while. Watch for vibration or wobbling that could indicate poor

installation or a poorly balanced wheel.

21. Use the specified surface of the wheel to perform the grinding.
22. Watch out for flying sparks. Hold the tool so that sparks fly away from you and other persons or flammable materials.
23. Do not leave the tool running. Operate the tool only when hand-held.
24. Do not touch the workpiece immediately after operation; it may be extremely hot and could burn your skin.
25. Always be sure that the tool is switched off and unplugged or that the battery cartridge is removed before carrying out any work on the tool.
26. Observe the instructions of the manufacturer for correct mounting and use of wheels. Handle and store wheels with care.
27. Do not use separate reducing bushings or adaptors to adapt large hole abrasive wheels.
28. Use only flanges specified for this tool.
29. For tools intended to be fitted with threaded hole wheel, ensure that the thread in the wheel is long enough to accept the spindle length.
30. Check that the workpiece is properly supported.
31. Pay attention that the wheel continues to rotate after the tool is switched off.
32. If working place is extremely hot and humid, or badly polluted by conductive dust, use a short-circuit breaker (30 mA) to assure operator safety.
33. Do not use the tool on any materials containing asbestos.
34. Do not use water or grinding lubricant.
35. Ensure that ventilation openings are kept clear when working in dusty conditions. If it should become necessary to clear dust, first disconnect the tool from the mains supply (use nonmetallic objects) and avoid damaging internal parts.
36. When use cut-off wheel, always work with the dust collecting wheel guard required by domestic regulation.
37. Cutting discs must not be subjected to any lateral pressure

FUNCTIONAL DESCRIPTION

A CAUTION: Always be sure that the tool is switched off and unplugged before adjusting or checking function on the tool.
A CAUTION: Return the slide switch to the "O (OFF)" position in case

of accidental unplugging, blackout, or the power is cut unintentionally. Otherwise the tool may start suddenly when the power returns and it may result in personal injury.

Shaft lock

Press the shaft lock to prevent spindle rotation when installing or removing accessories.

1. Shaft lock

NOTICE: Never actuate the shaft lock when the spindle is moving. The tool may be damaged

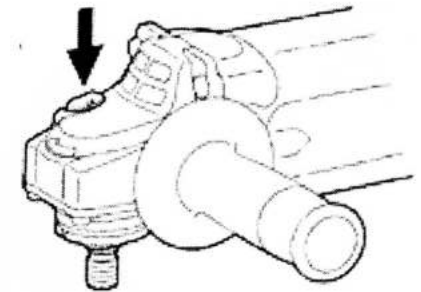

Switch action

A CAUTION: Before plugging in the tool, always check to see that the switch trigger actuates properly and returns to the "OFF" position when released.

1. Lock button / Lock-off button
2. Switch trigger

A CAUTION: Switch can be locked in "ON" position for ease of operator comfort during extended use.

Apply caution when locking tool in "ON" position and maintain firm grasp on tool. To start the tool, simply pull the switch trigger. Release the switch trigger to stop.

For continuous operation, pull the switch trigger and then push in the lock button.

To stop the tool from the locked position, pull the switch trigger fully, then release it.

NOTICE: Do not pull the switch trigger hard without pressing in the lock-off button. This can cause switch breakage.

ASSEMBLY

A CAUTION: Always be sure that the tool is switched off and unplugged before carrying out any work on the tool.

Installing side grip

A CAUTION: Always be sure that the side grip is installed securely

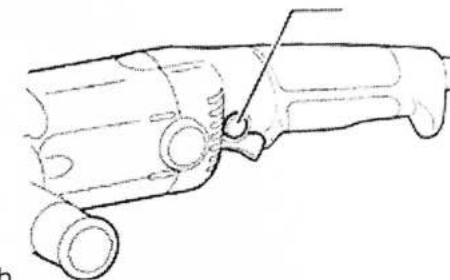

before operation.

Screw the side grip securely on the position of the tool as shown in the figure.

Installing or removing wheel guard (For depressed center wheel, flap disc, flex wheel, wire wheel brush/abrasive cut-off wheel, diamond wheel)

A WARNING: When using a depressed center wheel, flap disc, flex wheel or wire wheel brush, and the wheel guard must be fitted on the tool so that the closed side of the guard always points toward the operator.

A WARNING: When using an abrasive cut-off/ diamond wheel, be sure to use only the special wheel guard designed for use with cut-off wheels.

(In some European countries, when using a diamond wheel, the ordinary guard can be used. Follow the regulations in your country.)

Mount the wheel guard with the protrusion on the wheel guard band aligned with the notch on the bearing box. Then rotate the wheel guard around 180 degrees counterclockwise. Be sure to tighten the screw securely. To remove wheel guard, follow the installation procedure in reverse.

Installing or removing depressed center wheel or flap disc

Optional accessory

A WARNING: When using a depressed center wheel or flap disc, the wheel guard must be fitted on the tool so that the closed side of the guard always points toward the operator.

A WARNING: Never use a grinding wheel which is more than 6.5 mm thick.

A CAUTION: Make sure that the mounting part of the inner tangents into the inner diameter of the depressed center wheel/ flap disc perfectly.

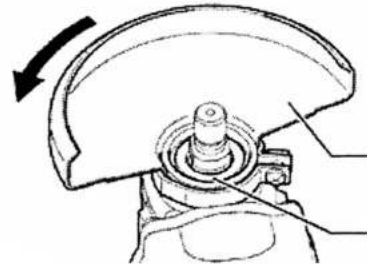
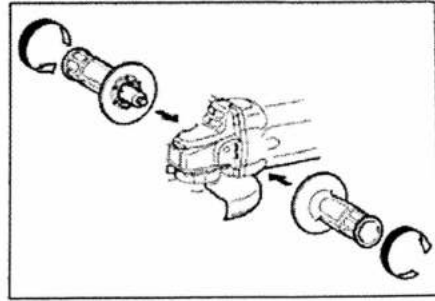

1.Wheel guard 2. Screw 3. Bearing box

Mount the inner flange onto the spindle. Fit the wheel/disc on the inner flange and screw the lock nut onto the spindle

To tighten the lock nut, press the shaft lock firmly so that the spindle cannot revolve, then use the lock nut wrench and securely tighten clockwise.

To tighten the lock nut, press the shaft lock firmly so that the spindle cannot revolve, then use the lock nut wrench and securely tighten clockwise.

To remove the wheel, follow the installation procedure

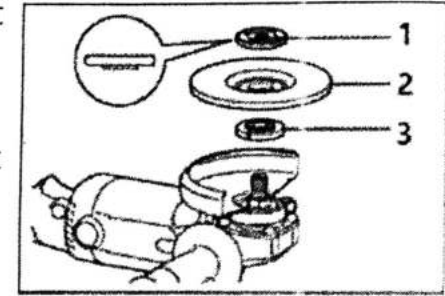

2.Depressed center grinding wheel/Multi-disc
3.Inner flange

OPERATION

A CAUTION: Never switch on the tool when it is in contact with the workpiece, it may cause an injury to operator.

ACAUTION: Always wear safety goggles or a face shield during operation.

ACAUTION: After operation, always switch off the tool and wait until the wheel has come to a complete stop before putting the tool down.

ACAUTION: ALWAYS hold the tool firmly with one hand on housing and the other on the side handle.

AWARNING: It should never be necessary to force the tool. The weight of the tool applies adequate pressure. Forcing and excessive pressure could cause dangerous wheel breakage

AWARNING: NEVER bang or hit grinding disc or wheel onto work.

AWARNING: Avoid bouncing and snagging the wheel, especially when working corners, sharp edges etc. This can cause loss of control and kickback.

AWARNING: NEVER use tool with wood cutting

blades and other saw blades. Such blades when used on a grinder frequently kick and cause loss of control leading to personal injury.

Grinding and sanding operation

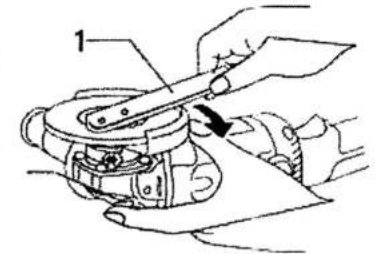

1. Lock nut wrench 2. Shaft lock

ALWAYS hold the tool firmly with one hand on rear handle and the other on the side handle. Turn the tool on and then apply the wheel or disc to the workpiece.

In general, keep the edge of the wheel or disc at an angle of about 15 degrees to the workpiece surface.

During the break-in period with a new wheel, do not work the grinder in the B direction or it will cut into the workpiece. Once the edge of the wheel has been rounded off by use, the wheel may be worked in both A and B direction

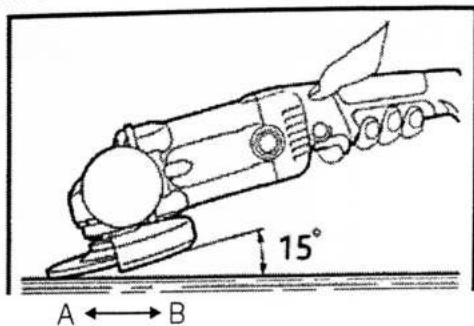

MAINTENANCE

CAUTION: Always be sure that the tool is switched off and unplugged before attempting to perform inspection or maintenance.

NOTICE: Never use gasoline, benzine, thinner, alcohol or the like. Discolorations, deformation or cracks may result.

Air vent cleaning

The tool and its air vents have to be kept clean regularly clean the tool's air vents or whenever the vents start to become obstructed.

Remove and check the carbon brushes regularly. Replace when they wear down to the limit mark. Keep the carbon brushes clean and free to slip in the holders. Both carbon brushes should be replaced at the same time. Use only identical carbon brushes

Use a screwdriver to remove the brush holder caps. Take out the worn carbon brushes, insert the new ones and secure the brush holder caps.

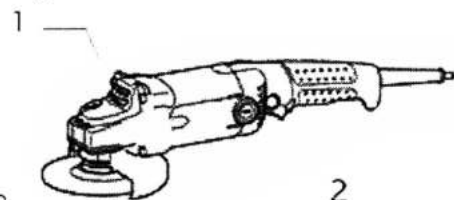

1. Exhaust vent 2. Inhalation vent

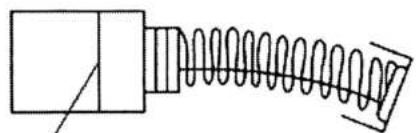

1. Limit mark

To maintain product SAFETY and RELIABILITY, repairs, any other maintenance or adjustment should be performed by Authorized Service Centers, always using original replacement parts

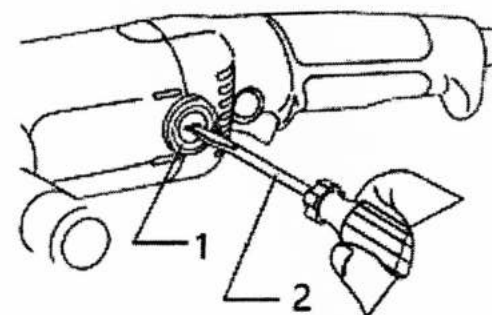

1. Brush holder cap 2. Screwdriver