

vatti

INSTRUCTION MANUAL

TABLE GAS STOVE

2-11SRB LPG

Please read this instruction manual carefully before using.

GAS STOVE PARTS

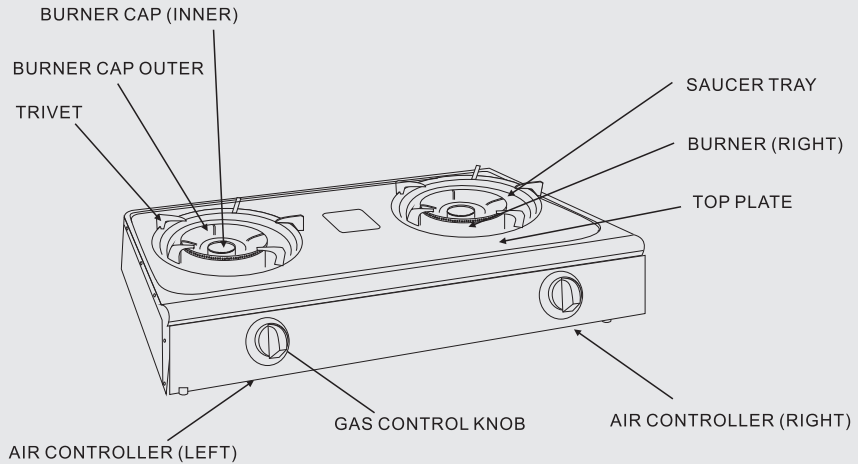

FEATURES:

1. Automatic Electronic Ignition
The gas is ignited by a spark from a special piezo-electric element. No batteries or matches are needed with the long lasting piezo-electric element.
2. Attractive Top Plate Attractively designed, made of stainless steel.
3. High-Thermal Heat and Efficient Burners
Durable, economical gas burners, designed to give you the ideal cooking for any size and shape of pot, pan or casserole.
4. Large Trivets
Both trivets can accommodate large pot and frying pan all at the same time.
5. Detachable Burner Cap for convenient cleaning and maintenance.
6. TRIPLE BURNER Two large+one small brass burner

PREPARATION:

1. Match properly your gas cylinder and gas regulator.
2. When unpacked, make sure that all of the parts of the gas stove are included.
3. Place your Gas Cooker on a level and firm location.
4. Install burner cap main on its place. Place the double burner head-closed type on the left side, open-type on the right side and small one on the middle as shown in Figure 1.
5. Place the saucer trays on its place. Saucer tray with larger hole in on the right side. And the small saucer tray on the middle.
6. Place the trivets on top the saucer trays.
7. Push the gas hose into the hose joint to its maximum insertion.

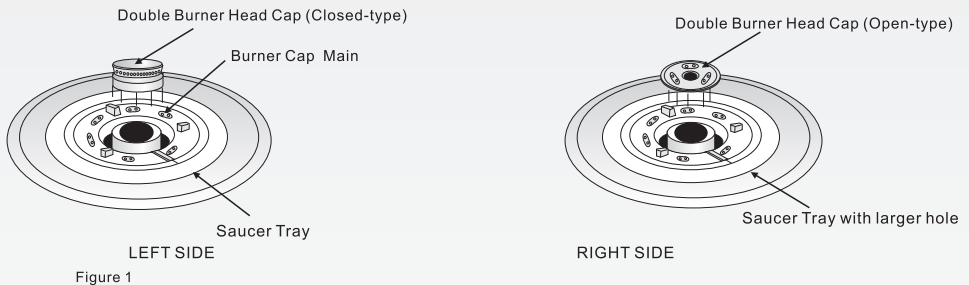

HOW TO USE:

To ignite the burners:

1. Open the main gas valve of the gas cylinder. Gently push the gas control knob in and turn it counter-clockwise to ON position until you hear the ignition click, then release the knob. Make sure that the gas is ignited. Repeat this procedure if ignition fails the first time. Note: Never left the gas control knob open when ignition fails.
2. Initial ignition will simultaneously light the inner small burner and outer big burner. To use the inner small burner only, turn the knob to MIN position or to its farthest turn.
3. Adjust the flame to suit cooking by turning the knob between the “ON” and “OFF” position.
4. For proper bluish flame, you may adjust the air flow by turning the air controller situated below the stove either towards the left or right until the flame becomes slightly round and bluish in color. Note: Tip of inner flame is slightly rounded



PRECAUTION:

Read the instructions carefully before using the unit to ensure proper operation.



1. The top plate becomes HOT. DO NOT TOUCH IT!
2. Do not apply excessive pressure on the gas control knob.

3. To avoid damage, do not place completely filled very large pots on cooker.

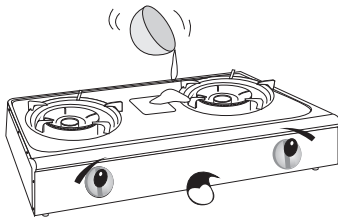
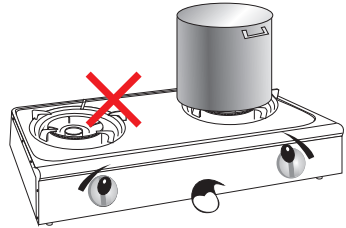

4. Protect the electric ignition system from liquid spill.

5. Do not allow the holes of the burner to become dogged with food residues.

CARE AND MAINTENANCE:

1. Wipe the top and body with a dry cloth. If it is difficult to clean, use soapy water and then dry thoroughly with a dry cloth.
2. Use steel wire to clean the holes of the burners. If water is used, be sure to dry thoroughly. Saucer trays can also be moved easily for clearing. Dry thoroughly before replacing.
3. Check the gas hose regularly for wear or leaks. It must be replaced occasionally. Keep it away from heat sources.
4. Avoid flammable substances near your Gas Cooker.

5. Place your Gas Cooker on a well-ventilated and dry area.

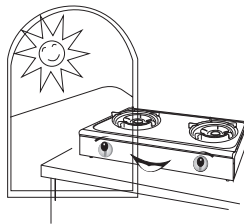

6. If the igniter is no longer functioning, call our nearest service center or a qualified technician.