

HAND BLENDER



USER MANUAL SM0795 SERIES CONTENT

IMPORTANT SAFETY INSTRUCTIONS.....	1
TECHNICAL DATA OF THE PRODUCT	2
PART NAME.....	3
INSTRUCTIONS FOR USE.....	4
RECIPES.....	6
ABNORMALITY ANALYSIS AND HANDLING.....	7
CLEANING AND MAINTENANCE	8
CIRCUIT PRINCIPLE DIAGRAM.....	9

IMPORTANT NOTE: Please read the manual carefully before operating your product. Retain it for future reference.

IMPORTANT SAFETY INSTRUCTIONS

To avoid the risk of serious injury when using your hand blender, basic safety precautions should be followed, including the following.

READ ALL INSTRUCTIONS, SAFEGUARDS, AND WARNINGS BEFORE OPERATING BLENDER

1. To protect against risk of electrical shock do not put into water or other liquid.
2. Close supervision is necessary when any appliance is used by or near children.
3. Unplug from outlet when not in use, before putting on or taking off parts, and before cleaning.
4. Avoid contacting moving parts.
5. Do not operate any appliance with a damaged cord or plug or after the appliance malfunctions, or is dropped or damaged in any manner. Return appliance to the nearest authorized service facility for examination, repair or electrical or mechanical adjustment.
6. The use of attachments not recommended or sold by the manufacturer may cause fire, electric shock or injury.
7. Do not use outdoors.
8. Do not let cord hang over edge of table or counter.
9. Do not let cord contact hot surface, including the stove.
10. Keep hands and utensils out of container while blending to reduce the risk of severe injury to persons or damage to the blender. A scraper may be used but must be used only when the blender is not running
11. Blades are sharp. Handle carefully.
12. To reduce the risk of injury, never place cutter-assembly blades on base without jar properly attached.

IMPORTANT SAFETY INSTRUCTIONS

13. Always operate blender with cover in place.
14. The use of attachments, including canning jars, not recommended by the manufacturer may cause a risk of injury to persons.
15. Do not blend hot liquids.
16. Do not modify the plug in any way.

**SAVE THESE INSTRUCTION.
THIS UNIT IS INTENDED FOR HOUSEHOLD
USE ONLY.**

Caution:

The failure to follow any of the important safeguards and the important instructions for safe use is a misuse of your hand blender that can void your warranty and create the risk of serious injury.

TECHNICAL DATA OF THE PRODUCT

Product name	Model No.	Rated voltage	Rated frequency	Rated power
HAND BLENDER	SM0795	220-240V~	50-60Hz	300W

PART NAME

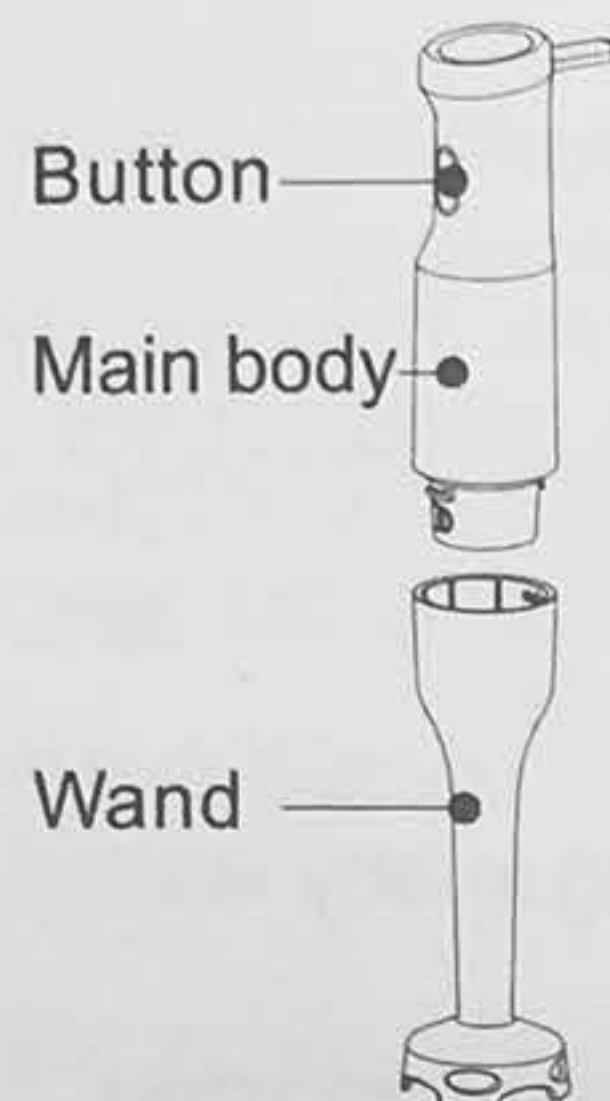

Button

Main body

Wand

ACCESSORIES (optional)



Whisk

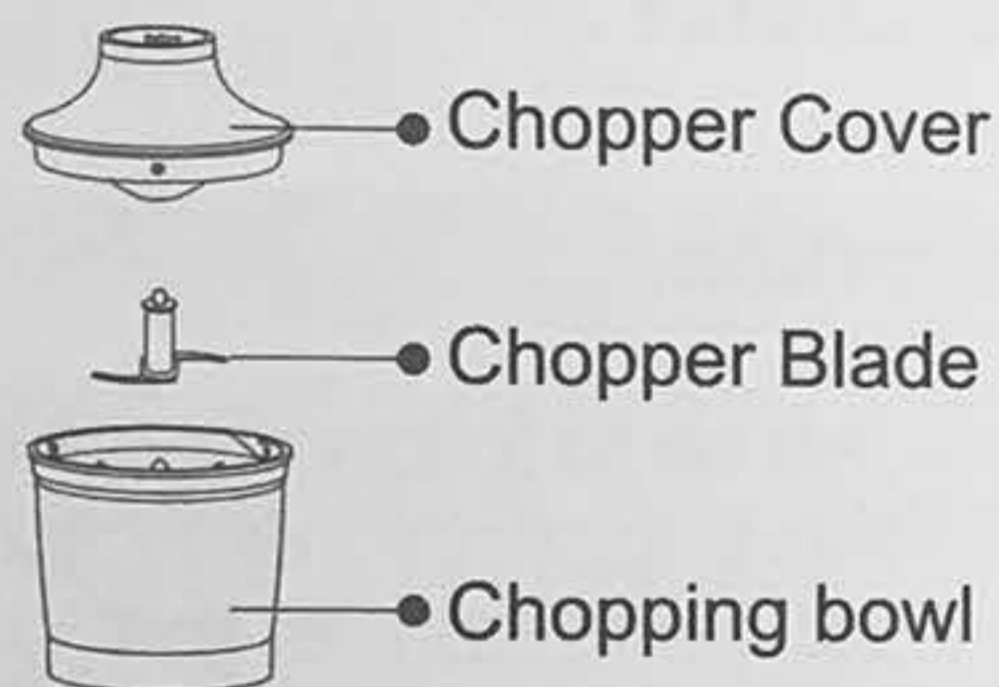

Chopper Cover

Chopper Blade

Chopping bowl

Chopper

Note:

- The hand blender is not designed for use over a heat source.
- This appliance is not intended to chop ice.
- To use the hand blender in a saucepan, be sure to remove the pan from the stove.
- To puree foods, liquid is needed. Add cooking liquid, broth, juice, milk, or cream until desired consistency is reached.
- For thorough blending, move hand blender up and down in mixture until smooth.
- To achieve best blending results and to reduce splattering (especially hot foods or liquids), use deep, tall containers.
- We recommend chopping only 5oz. (142g) of meat at a time in the food chopper. Meat should be cut into 2-inch (5.1-cm) pieces before processing.
- Don't allow to use hand blender on long time.

INSTRUCTIONS FOR USE

hand blender/whisk attachment

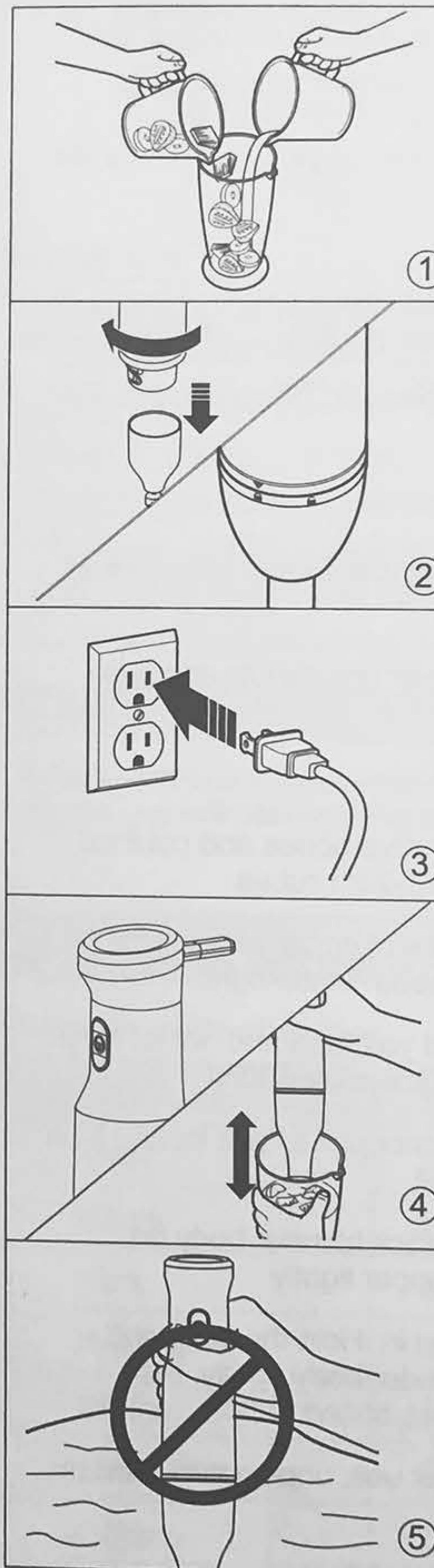

According to require assembled appliance body and attachment, let every attachment be locked completely. Assembled way be showed on picture.

Wand use

You can blend baby food, soups, sauces, milk shakes and Mayon-naise

Wand used on beaker

- Please check over accessory is run good before use appliance for blend food.
- Put the beaker on a worktop, and pour not over 600ml food or mixture into it
- Assembled appliance body and wand completely (wand be locked on appliance body)
- Put appliance plug into socket of supply power.
- Hold appliance body tightly and let finger can easy operate speed button.
- Put wand into beaker, then press speed button(according you need choose speed)
- Move appliance up-down, right-left slowly, until food be blended good
- Release speed button, let blade be stop, and put out appliance, Pull out power cord from socket or shut off appliance power if need blend another food.
- Take a cool pan and put it on worktable, assemble blender body and wand tightly
- Plug in. To avoid splashing, place the blade in food before switching on Hold the beaker steady, then press either speed button
- Don't let liquid get above the join between the power handle and blender shaft

INSTRUCTIONS FOR USE

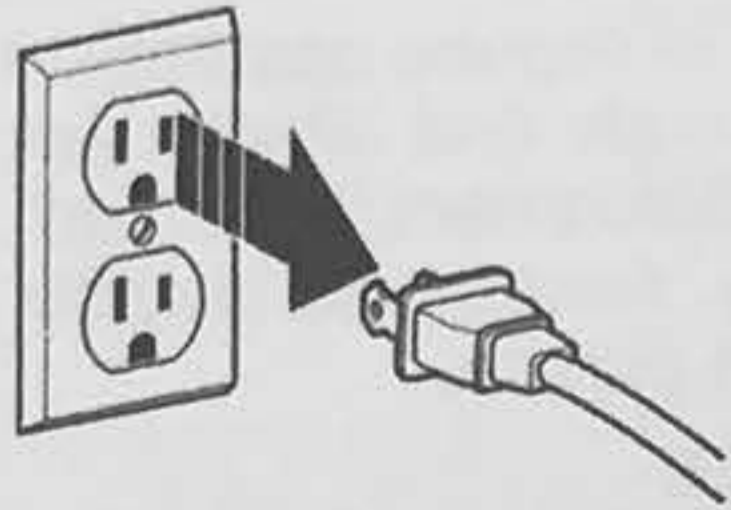

⑥

- Move the blade through the food and use a stabbing action.
- If you blender gets blocked, unplug before clearing.
- After use, unplug and dismantle

⚠ Caution:

- ▶ Do not use nonfood items in this hand blender. This product is not meant for soap making.
- ▶ Do not immerse the motor unit in water.
- ▶ Always inspect attachments before each use. Do not use cracked, bent, or damaged attachments.

Working time is not recommended to over one minute at a cycle

chopper



①

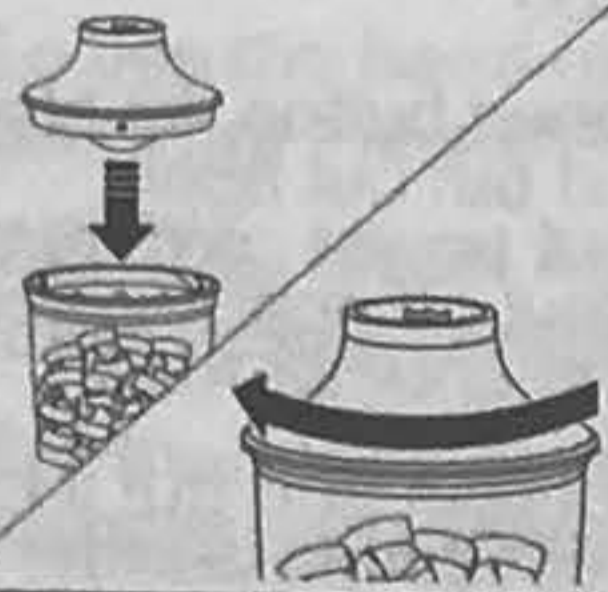

②

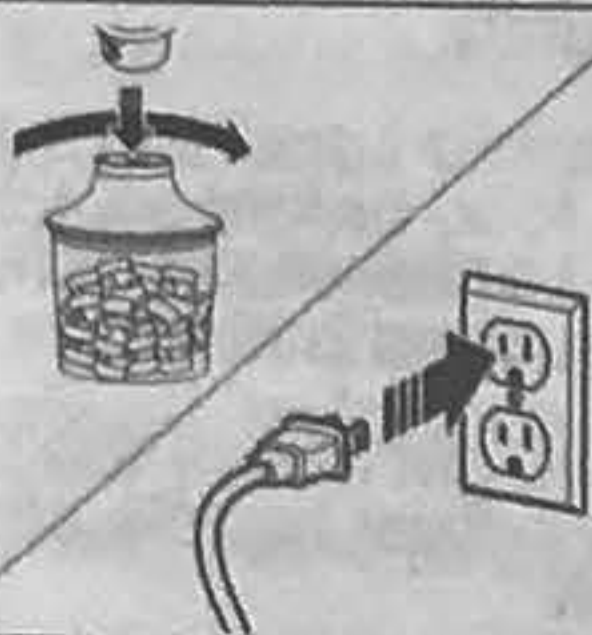

③

- Remove bones and cut food into 1-2cm cubes
- Open chopper lid and fit chopper blade right
- Add you food and not let food volume over 500ml
- Fit chopper lid and locked it on bowl
- Fit stick blender body on chopper tightly
- Plug in. Hold the bowl and blender body tightly, then press speed button
- After use, unplug and dismantle

INSTRUCTIONS FOR USE



④

📌 Note:

You can chop meat, cheese, vegetable, herbs, bread, biscuits and nuts, but not permit use it to chop hard food such as coffee bean, ice cubes, spices or chocolate, otherwise will damage the blade.

Whisk use

Whisk used to make light ingredients such as egg whites, cream instant dessert, eggs and sugar for whisked sponges.

- Push the wire whisk into the whisk body and fit this whisk-ASM to stick blender body and turn & lock it.
- Place you food in a bowl.
- Plug in, move the whisk clockwise.
- After use, unplug in and dismantle it.
- Don't whisk more than four eggs whites or 400ml(3/4 Pt) cream.
- Don't let liquid get above the whisk wires.

📌 Note:

Please not use it whisk heavier mixtures such as margarine and sugar, you will damage the whisk.

RECIPES

Formula with chopper

Food type	Maximum amount	Approx. time(S)
Meat	200g (7.0 Oz)	5
Herbs	20g (0.7 Oz)	20
Nuts	200g (7.0 Oz)	30
Cheese	150g (5.0 Oz)	30
Bread	1 slice	50
Hardboiled egg	2	5
Onions	100g (3.5 Oz)	10

RECIPES

Formula with wand

Food type	Maximum amount	Approx. time(S)
Carrot	280g carrot +420g water	60
Whipping cream	300g	30
Banana milk	500ml milk and a banana cut to four pieces	60

ABNORMALITY ANALYSIS AND HANDLING

Abnormality Handling

1. In case of abnormalities such as abnormal noises, smell, smoke, etc., you should immediately cut off power and stop use.
2. If the product cannot work, please check if the power supply is connected, if the switch is put to the ON position and if fittings are installed in place.
3. If the product still cannot work after checks mentioned above, please consult the designated repair centre for maintenance.

Fault Analysis and Elimination

Symptom	Analysis of Possible Causes	Countermeasure
Product does not work	Did not press the inching switch	Keep the point switch in the pressed state
Mixing sword master	Excessive amount of food processing	Reduce the quantity of ingredients
	Ingredients stick to blade	Cut off the power supply, clean up the blade on the ingredients
The abnormal odor products, hot, the phenomenon such as smoking	Excessive amount of food processing	Reduce the quantity of ingredients
	Product continuous working time is too long	Shorten the product continuous working time
	Processing the ingredients of temperature is too high	The temperature of the ingredients do not exceed 60 ° C

CLEANING AND MAINTENANCE

Cleaning

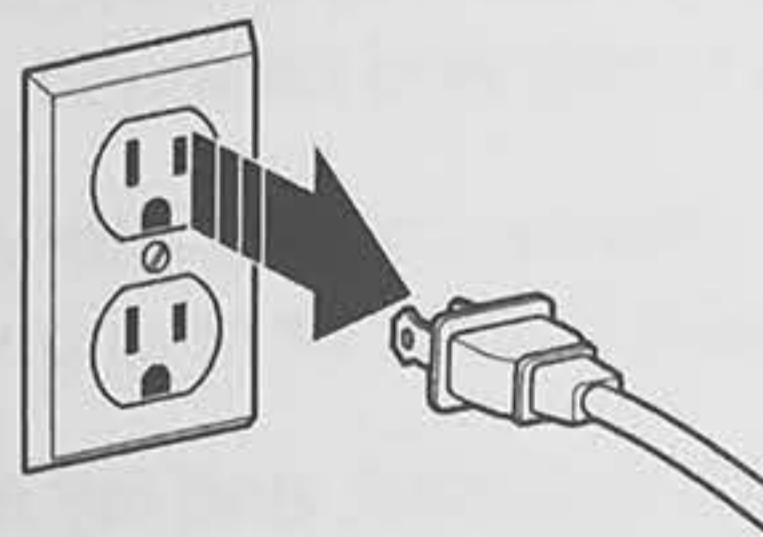

①

Always switch off and unplug when cleaning appliance.

Don't touch the sharp blades and keep special care when clearing blades avoid to be injured

Some food easy discolor plastic part, please rub with a cloth dipped in vegetable oil help remove discoloring.



②

Cleaning appliance body chopper lid, whisk body

Wipe with a damp cloth, then dry

Never immerse in water or use abrasives.

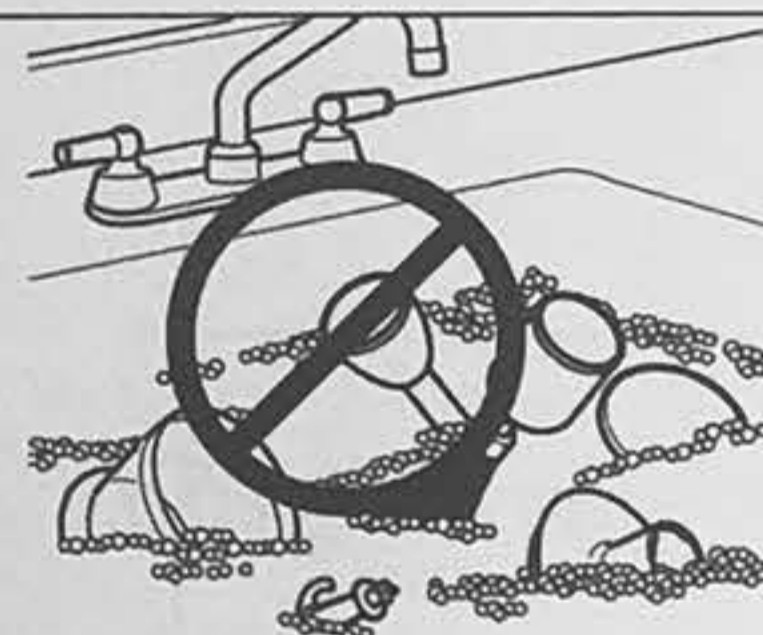

Chopper Lid, Whisk Holder
Wand Inner, Main Unit

③

Cleaning Wand, wire whisk

Unplug the power line, then take down the wand and whisk.

Wash the wand and whisk by water.

Use cloth to dry the water of wand and whisk.

⚠ Caution:

Never hold motor unit portion of hand blender under running water. Simply wipe clean with a damp cloth.

If you put the wand into the water to clean, you must pay attention to the following two aspects:

Height of water can't over the plastic part at top of wand.

Don't permit water or liquid be flow into stick blender body, wand. If water get inside, drain and dry it before use it.

CLEANING AND MAINTENANCE

Maintaining

- If the power cord be damaged, for safety reasons, it must be send to our company authorized shop repair and changed.
- If the appliance have un-normal state, please contact with shop where purchase this appliance and make it clear or change it.
- When not use the appliance, please coil the cord, and lay it on somewhere children cannot get it.
- Keep appliance on a dry condition when not use appliance.
- Don't plug in when not use appliance.

CIRCUIT PRINCIPLE DIAGRAM

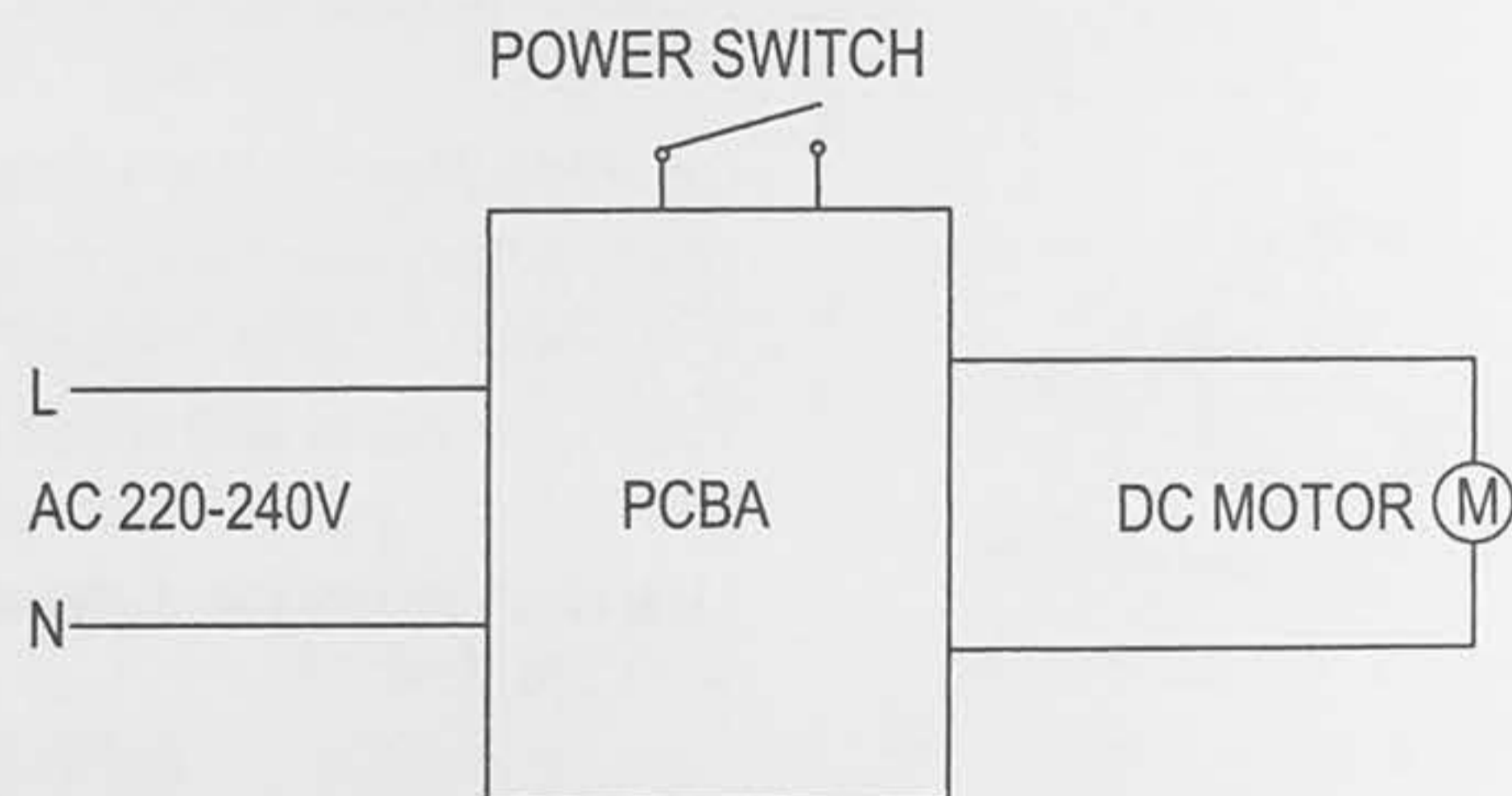

Environmental protection



The appliance must not be disposed of with regular household waste. At the end of its service life, the appliance must be properly delivered to a collection point for the recycling of electrical and electronic equipment. By Collection By Collection and recycling of old appliances, you are making an important contribution to the conservation of our natural resources and provide for environmentally sound and healthy disposal.