

Midas Gas Detector

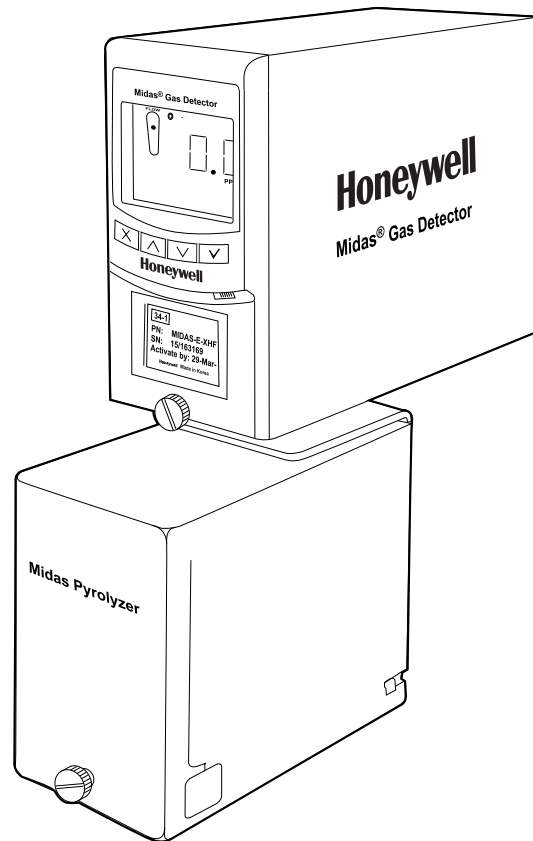

User Manual

- [Table of Contents](#)
- [Description](#)
- [Overview](#)
- [Default Configuration](#)
- [Installation](#)
- [Startup](#)
- [Operation](#)
- [Navigating Menu](#)
- [Maintenance](#)
- [Pyrolyzer Module Options](#)
- [LonWorks Interface](#)
- [Troubleshooting/Faults](#)
- [REFLEX](#)
- [Internal Web Server](#)
- [Installation Topologies](#)
- [Ordering Information](#)
- [Specifications](#)
- [Calibration/Bump Testing](#)
- [Modbus/TCP Interface](#)
- [Gas Tables](#)
- [Warranty](#)

Honeywell

Table of Contents

1 Description	1-2
2 Overview	2-2
2.1 Chassis	2-2
2.1.1 Display	2-2
2.1.2 Pump Module	2-3
2.1.3 Sensor Cartridge Chamber	2-3
2.2 Mounting Bracket Assembly	2-3
2.2.1 Mounting Bracket	2-4
2.2.2 Terminal Module	2-4
2.3 Sensor Cartridge	2-4
2.3.1 Biased Sensor Cartridges	2-4
2.4 Cover	2-5
3 Default Configuration	3-2
4 Installation	4-2
4.1 Mounting and Location of Detector	4-2
4.2 Mechanical Installation	4-4
4.3 Sample and Exhaust Tubing Calculations	4-7
4.5 Local Detector Option	4-8
4.6 Electrical Installation	4-8
4.7 Electrical Connections	4-11
4.8 Refitting the Main Chassis	4-23
4.9 Installing the Sensor Cartridge	4-23
5 Startup	5-2

6 Operation	6-2
6.1 Normal Operation Mode	6-2
6.1.1 Resetting Alarms, and Faults	6-4
6.2 Review Mode	6-4
6.2.1 Review Mode Menu Overview	6-4
6.3 Overview of Set-up, Calibration, and Test Mode	6-6
6.3.1 Set-up Menu Overview	6-6
6.3.2 Calibration Menu Overview	6-8
6.3.3 Test Menu Overview	6-10
7 Navigating Modes and Submenus	7-2
7.1 Review Mode	7-2
7.1.1 Review Software	7-2
7.1.2 Review Alarms	7-3
7.1.3 Review 4-20 mA Output	7-3
7.1.4 Review Faults	7-3
7.1.5 Review Calibration	7-4
7.1.6 Review Date and Time	7-4
7.1.7 Review Detector Address	7-5
7.1.8 Review Event Log	7-5
7.1.9 Review LCD Backlight Mode	7-6
7.2 Set-up, Calibration, and Test Modes	7-6
7.2.1 Set-up Menu	7-7
7.2.2 Set Alarms	7-7
7.2.3 Set 4-20 mA output	7-9
7.2.4 Set Faults	7-9
7.2.5 Set Calibration Interval	7-10
7.2.6 Set Date and Time	7-10
7.2.7 Set Address	7-11
7.2.8 Set pass code	7-12
7.2.9 Set LCD Backlight mode	7-13
7.2.10 Set Pump control frequency	7-13

7.3 Calibration Menu	7-14
7.3.1 Zero Calibration	7-14
7.3.2 Span Calibration	7-15
7.3.3 Flow Calibration	7-17
7.3.4 mA Calibration	7-18
7.4 Test Menu	7-18
7.4.1 Bump Test	7-19
7.4.2 Alarm/Fault Test	7-19
7.4.3 Inhibit State	7-20
7.4.4 Stimulate 4-20mA	7-21
8 Maintenance	8-2
8.1 Sensor Cartridge Replacement	8-3
8.1.1 Sensor Cartridge Fitting/Replacement.....	8-3
8.2 Pump Replacement	8-4
8.3 Reassembling the Detector	8-6
8.4 Filter Replacement	8-6
8.5 System Leak Check Procedure	8-7
9 Pyrolyzer Module Options	9-2
9.1 Fitting the Pyrolyzer Module.....	9-4
9.2 Reassembling the Detector.....	9-6
9.3 Configuring the Detector.....	9-7
10 Midas LonWorks Interface Module	10-2
10.1 LonWorks Installation	10-2
10.1.1 Fitting the LonWorks Module	10-2
10.1.2 Wiring the Midas for LonWorks	10-3
10.1.3 Configuring the Midas for LonWorks	10-3
10.2 LonWorks Software	10-4
10.2.1 LonWorks [®] Overview	10-4
10.2.2 Network Variable Behaviors	10-5
10.2.3 Other Characteristics	10-9

11 Troubleshooting and Fault Diagnosis	11-2
12 REFLEX	12-2
13 Internal Web Server	13-2
13.1 Physical Network Components	13-2
13.2 Internet Settings.....	13-2
13.3 Running the Web Browser	13-4
14 Typical Installation Topologies	14-2
14.1 Conventional Installation	14-2
14.2 Modbus/TCP Installation	14-3
14.3 Power over Ethernet (PoE) Installation.....	14-3
15 Ordering information.....	15-2
15.5 Midas Complete Gas Detector Kits	15-3
15.6 Accessories and Spares	15-4
16 Specifications	16-2
17 Calibration and Bump Testing.....	17-2
A Modbus/TCP Interface	A-2
A.1 Reading Status from the Midas	A-2
A.2 Sending Commands to the Midas	A-6
A.3 Determining the MAC Address	A-7
B Gas Tables	B-2
C Warranty.....	C-2
Sensor Cartridge Warranty	C-3
Pyrolyzer Warranty	C-3



EU Directive 2012/19/EU: Waste Electrical and Electronic Equipment (WEEE)

This symbol indicates that the product must not be disposed of as general industrial or domestic waste. This product should be disposed of through suitable WEEE disposal facilities. For more information about disposal of this product, contact your local authority, distributor or the manufacturer.

Honeywell

Midas[®] Gas Detector

1 Description

1 Description

The Midas® gas detector is an extractive gas sampling system that draws a sample locally or from a remote point to a sensor cartridge that is located inside the detector's chassis. A wide range of Asphyxiant, Toxic, Flammable, Pyrophoric, Corrosive, and Oxidizer (including Oxygen) gas sensor cartridges are available that enable detection of gases used or generated in the Semiconductor and other industries.

Midas® is wall mounted and displays gas concentration, alarm, fault and status information via its backlit LCD and LEDs. A simple to use 4-button keypad located under the display provides the facility to set-up, review, operate and make changes to the detector's configuration.

Midas® has flexible power and communications capabilities built in as standard. These include 3 on board relays, 0-21 mA analog output, Modbus/TCP outputs for signal and service connectivity as well as the innovative Power over Ethernet (PoE) connection that enables a single Ethernet connection to be made for all power, control and communication requirements. An optional LonWorks® interface is available.

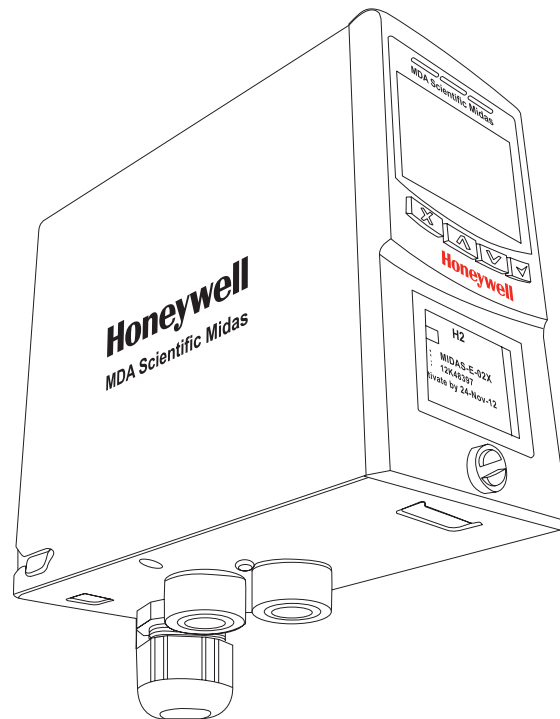

Honeywell

Midas[®] Gas Detector

2 Overview

Honeywell

Midas® Gas Detector

2 Overview

The Midas® gas detector comprises of 4 parts: the main chassis, the mounting bracket assembly, the sensor cartridge and the unit cover. Diagram 2-1 details the Midas® general arrangement. Additionally, optional Pyrolyzer modules for the detection of NF_3 or various PFCs and an optional LonWorks® module are available. Please refer to [Section 9](#) and [10](#) respectively for details of these options.

Diagram 2-1. Midas® general arrangement exploded view

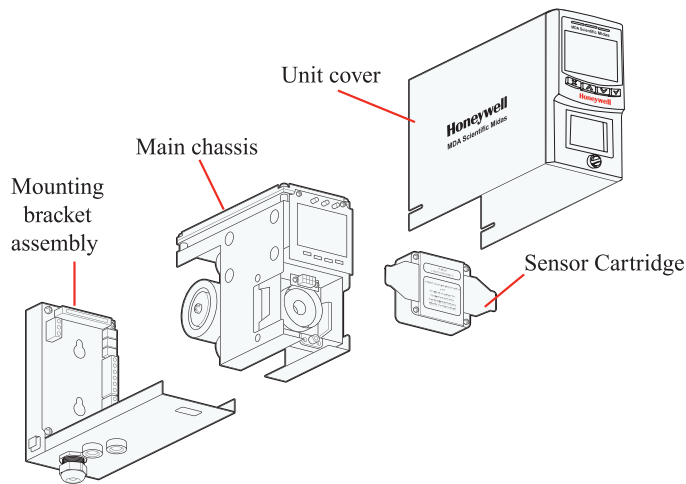

2.1 Chassis

The chassis comprises the display, pump assembly, and plug in sensor cartridge chamber.

Diagram 2-2. Main chassis

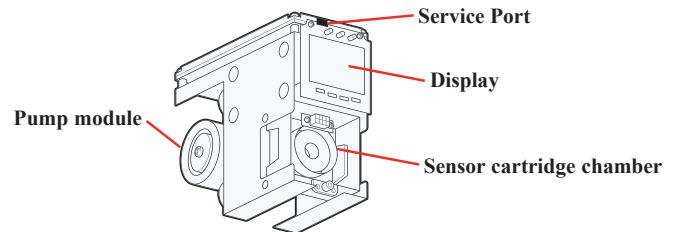

Caution

The Service Port is only for use with approved connectors by Honeywell Analytics service personnel operating a system diagnostic. Unauthorized connection to this port may lead to damage of the Midas® and external equipment and will not be covered by the normal product warranty conditions.

2.1.1 Display

The display is located at the front of the main chassis and consists of a large alphanumeric and graphical backlit LCD, 3 LED indicators and a 4-button keypad. Under normal operation the LCD and LEDs display gas concentration, alarm and system status. In set-up, review, calibration and test modes, the LCD shows the relevant menu options. These menus are simply navigated using the '▲' up, '▼' down, '✓' accept and 'X' cancel buttons.

Honeywell

Midas® Gas Detector

Diagram 2-3. Midas® display module layout

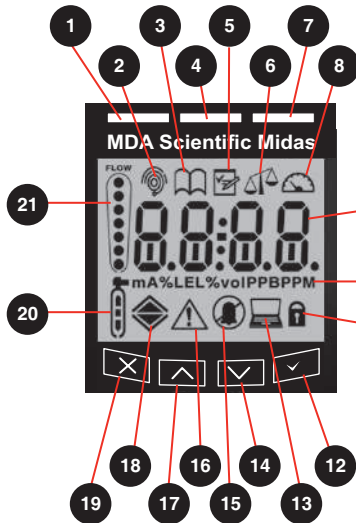

1. Red alarm LED
 2. Normal operation icon
 3. Review mode icon
 4. Green power LED
 5. Set-up mode icon
 6. Calibration mode icon
 7. Yellow Fault LED
 8. Test mode icon
 9. Gas concentration and message display area
 10. Displayed units
 11. Pass code icon
 12. Accept button
 13. Network icon
 14. Down button
 15. Inhibit icon
 16. Fault icon
 17. Up button
 18. Alarm level 1 icon s
 19. Alarm level 2 icon ▲
(For flammable and toxic)
 20. Depletion level 1 icon t
 21. Depletion alarm level 2 ▼
1. Cancel button
 2. Zero 0 and Span calibration icons
 3. Flow indicator

2.1.2 Pump Module

The pump module is located at the back of the main chassis. It draws the gas sample from the inlet port located at the bottom of the mounting bracket assembly via an inline filter to the sensor cartridge chamber located at the front of the main chassis. The inline filter is to protect the elements after the sensor. The sample goes from the inlet straight to the sensor face, and then through the rest of the flow system. The sample is then exhausted via the exhaust port located at the bottom of the mounting bracket assembly. The pump and filter assemblies are designed for easy replacement. For replacement details refer to [Sections 8.2](#) and [8.4](#).

2.1.3 Sensor Cartridge Chamber

The sensor cartridge chamber is located at the front of the main chassis below the display module. The plug in sensor cartridge is fitted into this area which makes the electrical connection between the sensor cartridge and the rest of the electronics as well as providing the chamber where the sensor cartridge is exposed to the sampled gas. This connection is lightly lubricated for ease of sensor replacement. Avoid contact of sensor cartridge chamber with contaminants (such as dust and debris). For details of fitting sensor cartridge refer to [Section 4.9](#).

2.2 Mounting Bracket Assembly

The mounting bracket assembly comprises of the detector mounting bracket, the terminal module, the gas sample inlet and outlet ports, the cable/conduit entry and Ethernet (Modbus/TCP) communications socket.

Diagram 2-4. Mounting bracket assembly

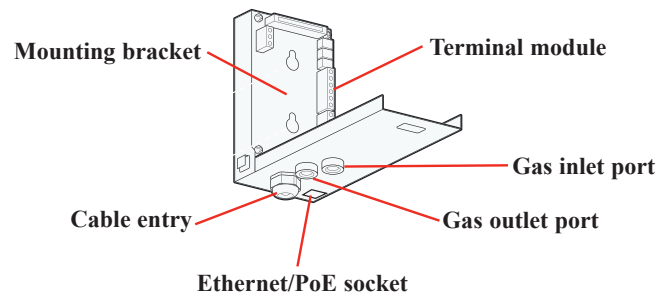

Honeywell

Midas® Gas Detector

2.2.1 Mounting Bracket

The metal mounting bracket has two slots that allow the detector to be easily mounted to a wall using two suitable screws (DIN rail or horizontal mounting options are also available). For further details of mounting the detector refer to [Section 4](#).

2.2.2 Terminal Module

The terminal module is located on the mounting bracket. All electrical connections to Midas® are made via this module. Wire entry to the terminal module area is via the PG16 cable entry/conduit entry located at the bottom of the mounting bracket assembly.

2.3 Sensor Cartridge

A wide range of Flammable, Pyrophoric, Corrosive, and Oxidizer (including Oxygen) sensor cartridges can be fitted to Midas®. The plug in sensor cartridges are fitted in the sensor cartridge chamber at the front of the main chassis. To access the chamber the unit cover is removed by unscrewing the thumbscrew located at the front of the detector. The pre-calibrated smart sensor cartridges can easily be fitted or replaced as they simply plug into the detector without the need for any tools. The sensor cartridge is firmly held in place by two locking tabs. Some cartridges are shipped with a protective cap to shield them from contaminants during shipping. This cap must be removed before inserting the cartridge into the Midas® unit, failure to do so may damage the Midas® transmitter.

Diagram 2-5. Sensor cartridge

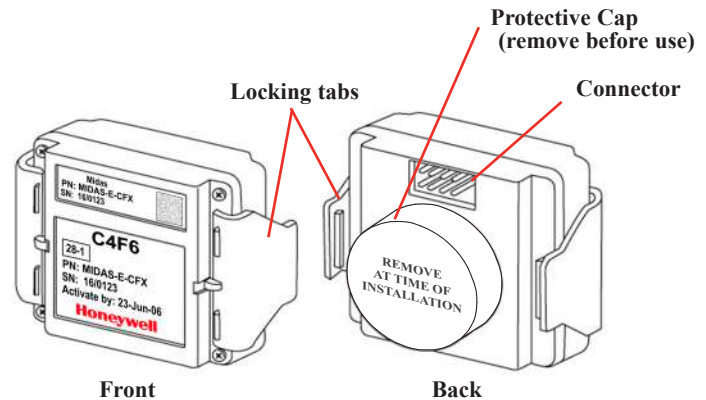

2.3.1 Biased Sensor Cartridges

Some sensor cartridges are shipped with a battery powered electrical supply in order to keep the cell effectively 'warmed up' and ready to monitor once installed in the Midas® unit. Battery powered bias circuits are supplied for TEOS, NO, and CO₂. The bias circuit is removed just before insertion into the Midas® system and the sensor cartridge is thus ready sooner for effective gas detection.

Should a bias voltage not be applied (e.g. during a power failure), the cell will take a longer time to recover before effective gas detection can take place. The longer the loss of applied power, the longer the recovery time. During this recovery time, there is a chance for false/inaccurate readings. Refer to the relevant sensor cartridge data sheet for information on each sensor cartridge.

In order to avoid the risk of loss of gas detection due to unforeseen power loss, we recommend that a power management solution such as uninterruptible power supplies are used.

Honeywell

Midas® Gas Detector

Note

Sensor warranty is void if the sensor cartridge is opened by unauthorized user.

Diagram 2-6. Biased Sensor.

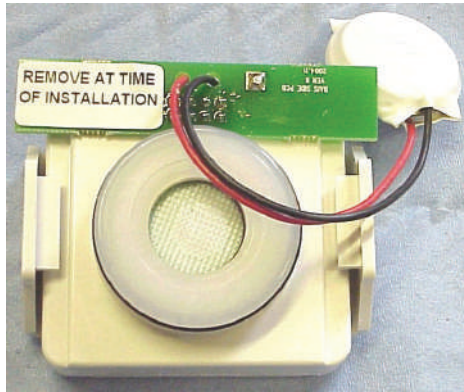
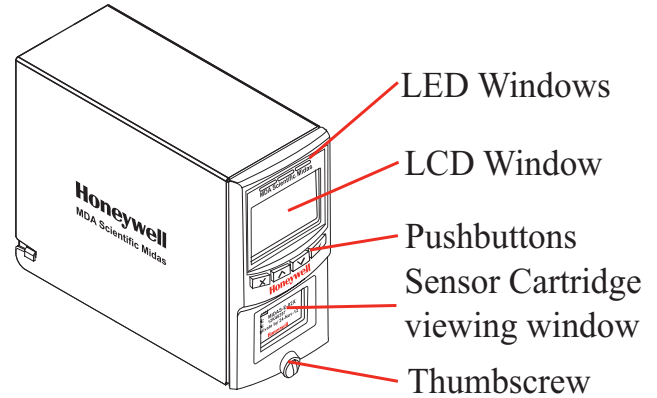

Diagram 2-7. Midas® covers



Standard Cover

2.4 Cover

The standard cover provides environmental protection and fits over the top, front and sides of the main chassis. The front panel has viewing windows for the LCD, LEDs and sensor cartridge fitted in the sensor cartridge chamber. Underneath the LCD window are the 4 push buttons used for navigating the detector's software menus. The cover is easily removed to allow access to the chassis by unscrewing the thumbscrew on the front panel and pulling the cover forwards off the main chassis.

Midas units fitted with a pyrolyzer utilize a ventilated cover due to the high temperatures generated by the pyrolyzer unit (See Diagram 2-7)

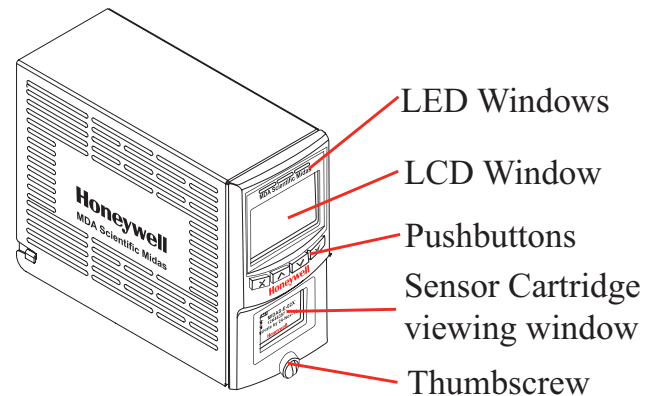

Ventilated Pyrolyzer Cover

3 Default Configuration

3 Default Configuration

NOTE: Oxygen levels are 20.9% v/v in a normal atmosphere, equivalent to 17.3 mA. Use caution when integrating an oxygen Midas unit using the 4-20 mA output since fault, inhibit, and no power conditions are below 4 mA and, by default, an oxygen depletion alarm is triggered on a falling alarm (default 19.5% v/v). In that case, Honeywell Analytics recommends one of the following:

- Use Modbus TCP digital communications
- Use discrete relay inputs instead of a 4-20 mA signal to trigger gas alarms
- Program the control system of the 4-20 mA input with logic and a delay (e.g., 1 second) before triggering an alarm to determine if the 4-20 mA output is at one of the 0-4 mA conditions described above.

Contact Honeywell Analytics for further information.

The Midas[®] gas detector is factory-configured as described in Table 3-1 on the following page.

Table 3-1. Midas® default configuration

Current source with:	1.0 mA 2.0 mA 3.0 mA 4.0 to 20.0 mA 21.0 mA	Fault Inhibit Maintenance Fault Gas reading (normal operation) Over range		
	Toxic Gas	Flammable Gas	Oxygen	
Full Scale (FS)	Typically 4 x Threshold Limit Value (TLV)	100% Lower Explosive Limit (LEL) ¹	25% Volume (v/v)	
Lowest Alarm Level (LAL)	Typically 1/2 TLV	10% LEL	5% v/v	
Alarm 1 (Relay 1)	1/2 TLV	10% LEL	23.5% v/v (Rising)	
	Normally de-energized, energizes on alarm. Contact Normally Open (NO), closes on alarm.			
Alarm 2 (Relay 2)	TLV	20% LEL	19.5% v/v (Falling)	
	Normally de-energized, energizes on alarm. Contact Normally Open (NO), closes on alarm.			
Fault (Relay 3)	Normally energized, de-energizes on fault. Contact Normally Open (NO). Instrument Fault Only			
Latching	Latching. Alarm and fault relays DO NOT automatically reset when reading falls below alarm thresholds. Relays MUST be manually reset.			
Pass code	No pass code set.			
IP Address	169.254.60.47 subnet mask 255.255.255.0			

¹ Midas® detectors are not ETL approved for monitoring in or sampling from classified areas above 25% LEL

See [Table 7-3](#) for more information on Relay Configuration

4 Installation

4 Installation

For ease of installation Midas[®] has been designed to allow the installation of the mounting bracket assembly and terminal module separately from the other parts of the detector. The detector location and hard wiring can therefore be completed before fitting the detector's main chassis and sensor cartridge.

WARNING

Midas[®] is designed for installation and use in indoor safe area non-explosive atmospheres. Installation must be in accordance with the recognized standards of the appropriate authority in the country concerned. Prior to carrying out any installation ensure local regulations and site procedures are followed.

Diagram 4-1. Midas[®] outline dimensions

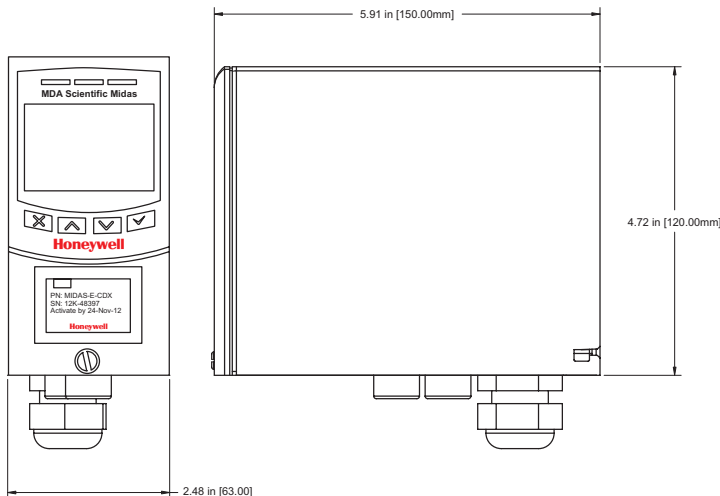

4.1 Mounting and Location of Detector

The Midas[®] gas detector has an integral mounting bracket assembly that is easily mounted to a suitable vertical surface such as a wall, tool housing, mounting plate on a pole etc.

Drill Template

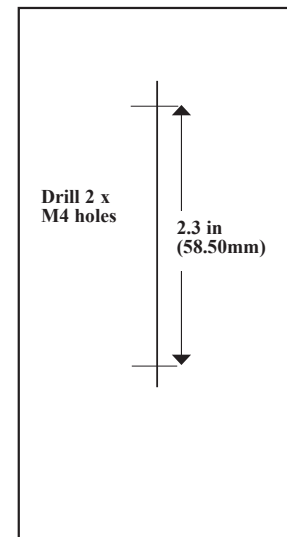

Note

This drill template is *not* to scale. The Midas Quick Start Guide (MIDAS-A-020) contains a full scale drawing.

Ensure all measurements are correct before using as an actual drill template.

Use 2 x M4 Screws or equivalent for mounting (head size 6-12 mm (1/4" - 1/2"))

Honeywell

Midas® Gas Detector

Midas® Transmitters and Pyrolyzers

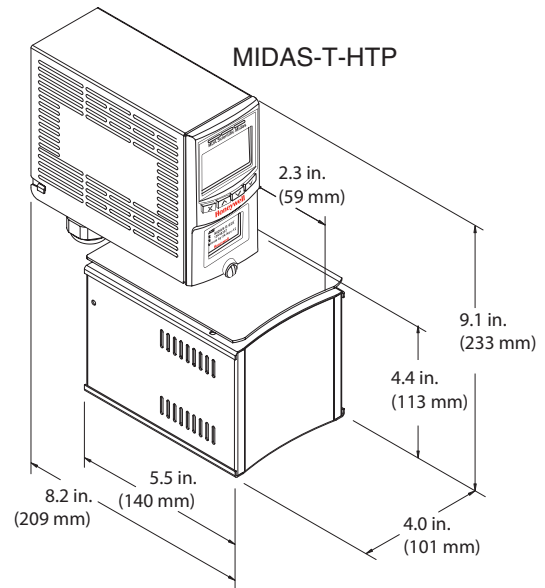
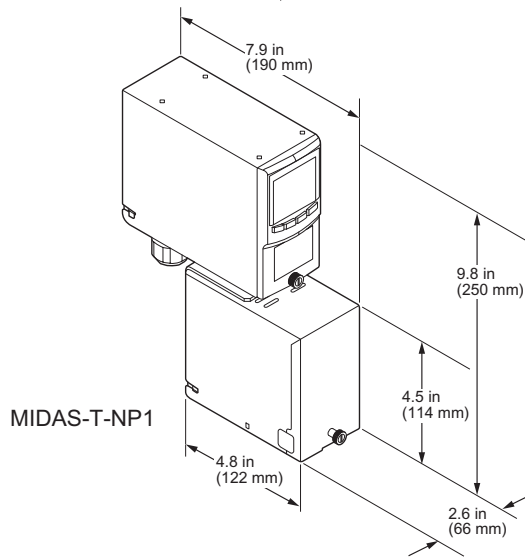
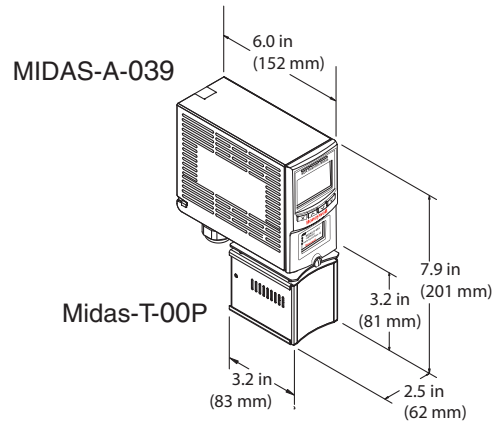
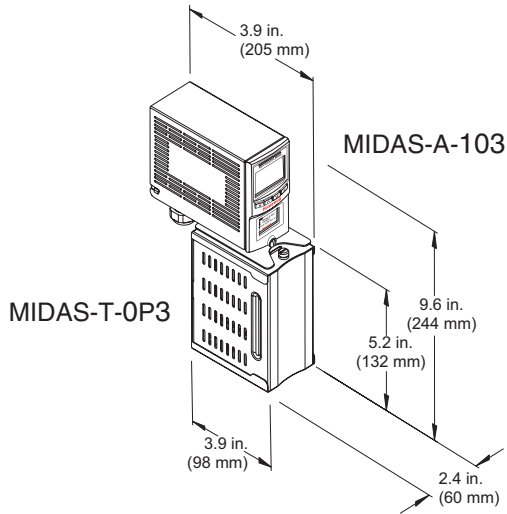

Note: Heat shield not present on all pyrolyzers.

Honeywell

Midas[®] Gas Detector

Below are some considerations when installing the Midas[®] Gas Detector:

1. Mount the detector on a surface that is flat, firm and suitable for its size and weight.
2. Use the drill template supplied to drill the holes for the fixings.
3. Use fasteners appropriate for the surface being mounted to.
4. Ensure the head size of fastener used will not snag the terminal PCB 6-12 mm (.25 in - .5 in).
5. Consider the conduit/cable weight and its stress on the installation.
6. Position the detector so that it can be easily accessed.
7. Position the detector so that it is at a suitable height (normally eye level) for the display to be clearly seen.
8. Take into consideration the space required to remove the detector's cover and locking/unlocking the sensor cartridge locking clips. Minimum recommended spacing between multiple Midas[®] units is 82 mm (3.23 in).
9. Take into consideration the space required for sample inlet and exhaust tubing (for remote monitoring), and for the inlet filter (for local monitoring).
10. Take into consideration the space required for cable or conduit access.

4.2 Mechanical Installation

The following steps and diagrams show how to separate the mounting bracket assembly from the main chassis and mount it on a vertical flat surface.

1. Unscrew the thumbscrew located on the front panel.
2. Remove the cover by pulling it forwards off the main chassis. Be sure to remove the internal packing card securing the pump. Failure to remove this packing will result in damage to the Midas[®] unit. (See Diagram 4-2)
3. Unscrew the two retaining screws located at the bottom front of the chassis.
4. Holding the mounting bracket assembly with one hand use the other to carefully pull the main chassis forward to disconnect it from the mounting bracket assembly.
5. Using the drill template provided drill two holes 58.50 mm vertically apart for 2 x round head M4 fixing screws.
6. Partially screw the fixings into the mounting surface.
7. Place the mounting bracket assembly over the screws so they pass through the mounting holes and then slide down to locate in the slots.
8. Tighten the screws to secure the mounting bracket assembly.

Honeywell

Midas® Gas Detector

Diagram 4-2. Mechanical installation

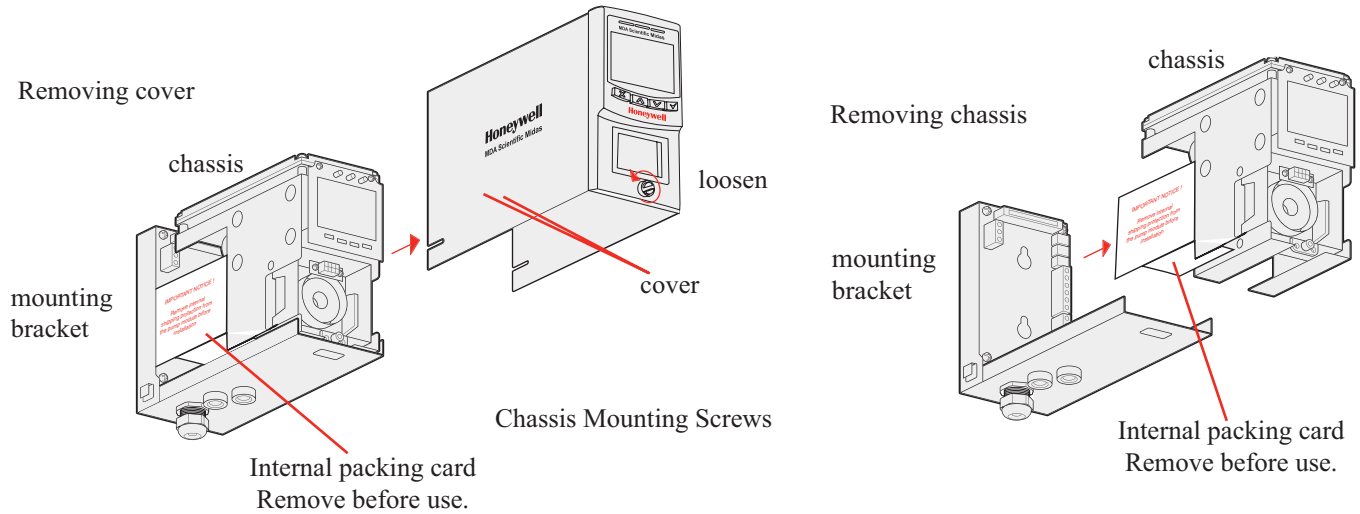

Honeywell

Midas® Gas Detector

Diagram 4-3. Mechanical installation

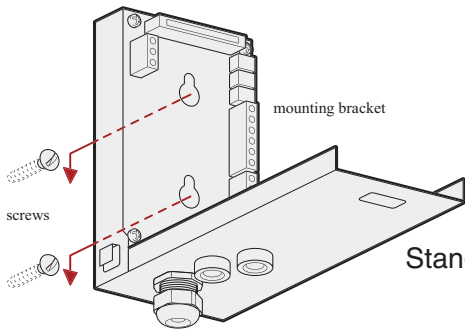

Standard Midas® Wall Mount

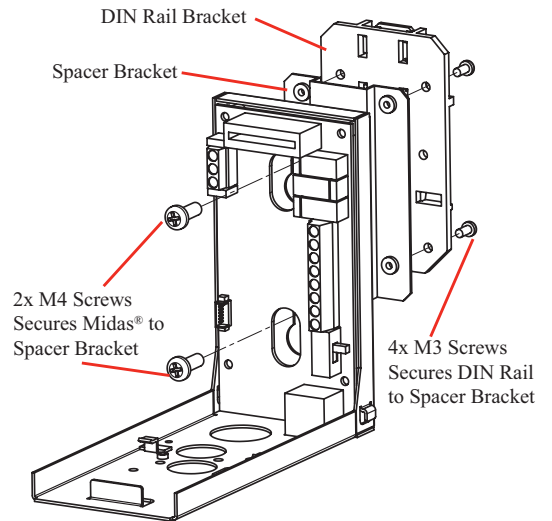

Optional Midas® DIN Rail Mount

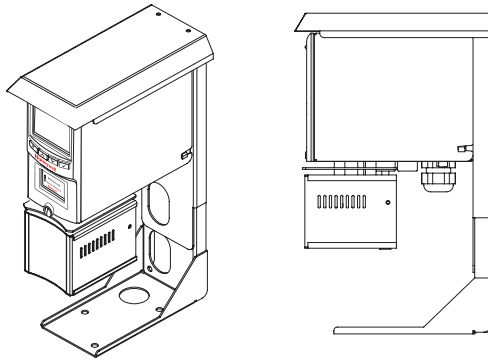

Optional Midas® Pyrolyzer Adjustable "L" Bracket Mount

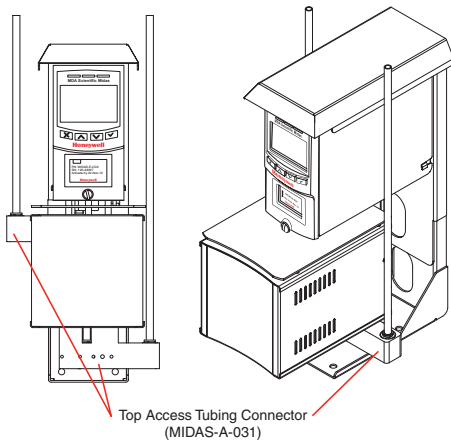

Note:

When using the Adjustable "L" bracket with the High-Temperature Pyrolyzer unit, (2) Top Access Tubing Connectors (MIDAS-A-031) must be used to insure proper operation.

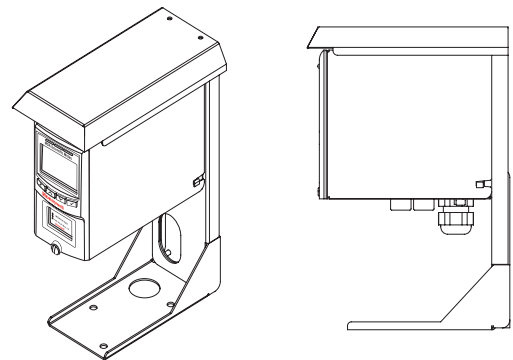

Optional Midas® Adjustable "L" Bracket Mount

4.3 Sample and Exhaust Tubing Calculations

The following tables show the flow rate, tubing length, transport time, and maximum pressure and vacuum at the inlet and exhaust points. Tubing lengths vary among gases. See [Appendix B](#) for recommended lengths.

Table 4-1. Inlet sample specifications

Inlet Sample Specifications:				
	Maximum			
Tubing Length, m (ft)	30 (100)	20 (66)	10 (33)	0
Transport Time (sec), ID 1/8" ¹	28	19	10	1
Transport Time (sec), ID 3/16"	63	43	23	1
Sample Point Vacuum (Negative pressure)	-25.4 cm H ₂ O (-10 in H ₂ O) Maximum			
Flow rate, cc/min.	500 (Flow is constant) ²			
Tubing OD, mm (in)	6.35 (0.25)			
Tubing ID, mm (in)	3.18 (0.125)			

¹ Honeywell Analytics recommends thick-wall tubing (1/8" ID) for best speed of response. Due to its lower surface area, thick-wall tubing may require less conditioning than thin-wall tubing.

² The flow rate is electronically maintained at approximately 500 cc/min and may vary within acceptable tolerances.

Table 4-2. Outlet sample specifications

Outlet Sample Specifications:	
	Maximum
Tubing Length, m (ft)	30 (100)
Back Pressure at Exhaust Point (Excluding tubing)	20.3 cm H ₂ O (8 in H ₂ O) Maximum
Tubing OD, mm (in)	6.35 (0.25)
Tubing ID, mm (in)	4.76 (0.188)

Note

Honeywell Analytics recommends the use of Teflon FEP (Fluorinated Ethylene Polymer) tubing to assure proper sample transport. The properties of Teflon FEP make it the best choice for transporting sample toxic gases to instruments when compared with the properties of other similar tubing materials.

If the pressure/vacuum on the inlet/exhaust lines does not meet the recommended values in Tables 4-1 and 4-2, the following chart describes potential fault conditions that may be brought on by the external influences thus resulting in an F81 Flow Fault.

	External Flow	Fluctuation	Fault 81	Explanation
1	Low (0-150 cc/min)	None	No	Midas® will auto-adjust
2	Low (0-150 cc/min)	Yes (up to 100 cc/min flow swings)	Likely	Midas® changes the flow gradually. If external flow changes are large and rapid, the final reading will be different from what Midas® expected. Midas® will issue Fault 81.
3	Medium (~200-450 cc/min)	Yes and No	Yes	Minimum flow rate for the pump is ~300 cc/min. With this external flow, the auto-adjust cannot work because the pump cannot produce a flow at this low level. The problem is worse if there are flow fluctuations.
4	High (> 600 cc/min)	Yes and No	Yes	Midas® cannot reduce the external flow. Midas® will issue Fault 81 due to high flow

Honeywell

Midas® Gas Detector

4.4 In-line Filters

External filters must be used to protect the tubing from contamination. Use particulate filter part number 780248 for normal gases and 1830-0055 or 1991-0147 for corrosive gases. Replace the filter every 3 months. Refer to [Appendix B](#) for specific gases.

4.5 Local Detector Option

The Midas® gas detector can also be used to monitor for gas at the location of the detector. To do this an inline filter is simply connected to the sensor cartridge gas inlet port. The external dust filter part number is 780248 for normal gases and 1830-0055 or 1991-0147 for corrosive gases. The area around the detector is then being monitored as opposed to a sample being drawn from a remote location.

Diagram 4-4. Local gas detector option

MIDAS-T-001 transmitter
installed with in line particulate
filter for local ambient monitoring
mode

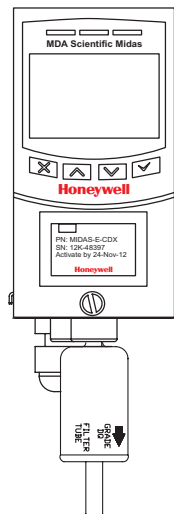

4.6 Electrical Installation

Access for the electrical wires to the terminal module is made via the PG16 cable gland located at the bottom of the mounting bracket assembly. The cable gland can be removed and replaced with a suitable conduit fitting if required. The wire routing of a typical installation is shown in the diagram below, wiring details are shown in [Diagram 4-6](#).

Diagram 4-5. Typical wire routing

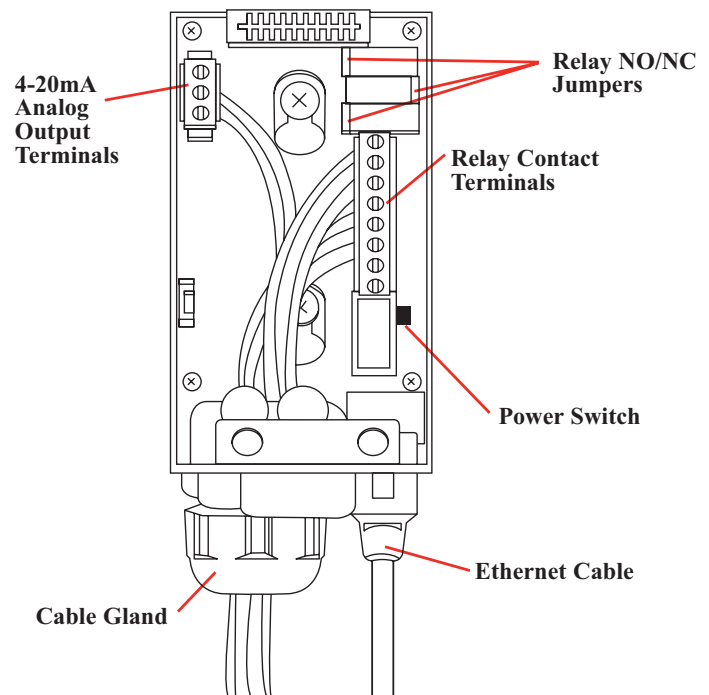

The terminals used are suitable for conductors of 24 to 14 AWG (0.5 to 1.8mm Dia.). The use of 16 AWG (1.5 mm Dia.) conductors is recommended.

If Power over Ethernet (PoE) is used to power the device, then 24 VDC power must **not** also be connected to the device, (or conversely if 24 VDC is used to power the Midas®, then electrical power via the Ethernet port must not be applied). Failure to observe this requirement may cause damage to the gas detection system and will not be covered by the standard warranty.

When connecting the wires ensure that the power switch is in the off position.

[Diagram 4-5](#) shows the terminal module layout and terminal identification as well as the jumper locations.

Note: Earthing Requirements

If the Midas® unit's metal chassis is not connected directly to a metal surface for earthing purposes, an additional earth wire will be required. Connect a wire via the PG16 gland to the dedicated earth tag (screw terminal) located on the bottom bracket and connect the other end of the wire to a dedicated external earthing point.

If Power over Ethernet (PoE) power supply is being used, shielded CAT5 Ethernet cable is recommended.

Please ensure that your wiring avoids earth ground loops that may affect the performance of your equipment

Honeywell

Midas® Gas Detector

Diagram 4-6. Midas® terminal layout and identification

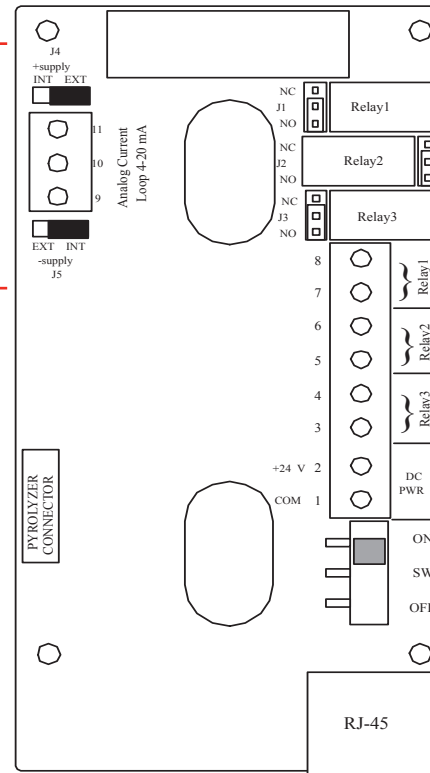
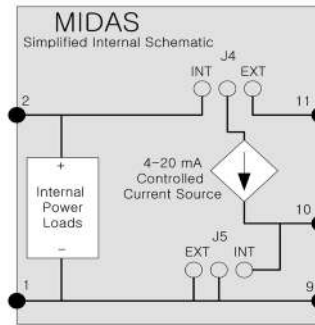

See Relay
function
table below

Relays
are user
configurable

Display	Description	Relay 1	Relay 2	Relay 3
1FLt	Instrument Fault Only	Alarm 1	Alarm 2	Instrument Fault
2Fit	Separate Fault Relays	Any Alarm	Maintenance Fault	Instrument Fault
CmbF	Combined Fault Relay	Alarm 1	Alarm 2	Any Fault
nEtr	Remote control of relays via Modbus/TCP or LonWorks®	Relays respond to Modbus or LonWorks® holding registers only.		

Note

The 3 relays onboard the Midas® unit can be controlled remotely from a separate controller system using Modbus/TCP commands (or via LonWorks® if the optional interface is used). In this remote mode, the relays cannot be controlled by the Midas® itself and only by the remote controller device (PLC, SCADA, etc.)

Honeywell

Midas® Gas Detector

4.7 Electrical Connections

Midas® can be powered by either 24 VDC via traditional discrete wiring or by approximately 48 VDC delivered through the Ethernet cable from a PoE source. In either case the 4-20 mA analog output can be used. This can be configured for fully isolated operation. With 24 VDC power the 4-20 mA output can be configured for sink, source or isolated output operations. Below are some schematic diagrams of typical electrical connection

configurations. Specific wiring instructions for connecting a Midas to a Honeywell Analytics Sieger System-57™ are provided on pages 4-12 to 4-16. Specific instructions for connection to a Honeywell Analytics TouchPoint™ are provided on pages 4-17 and 4-18 and the HA71 on pages 4-19 and 4-20.

Note:

When wiring the Midas Transmitter to a controller, program the controller for a 1-2 second delay before reporting to prevent false alarms.

**Diagram 4-7. Generic Example
Midas® 4-Wire Isolated Output**

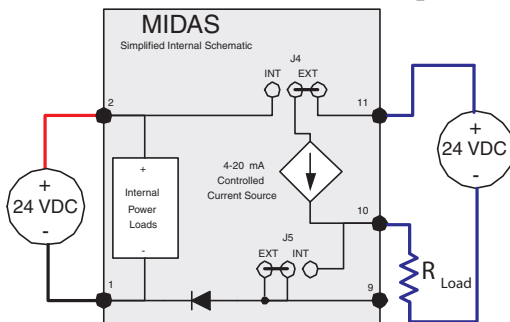

**Diagram 4-9. Generic Example
Midas® 3-Wire Sinking Output**

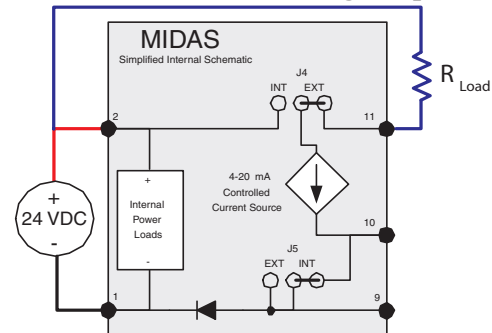

**Diagram 4-8. Generic Example
Midas® 3-Wire Sourcing**

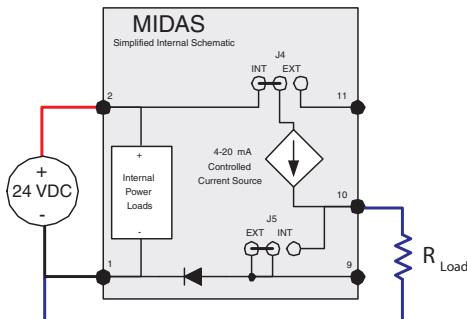

**Diagram 4-10. Generic Example
Midas® Isolated 4-20 mA Output w/PoE Power**

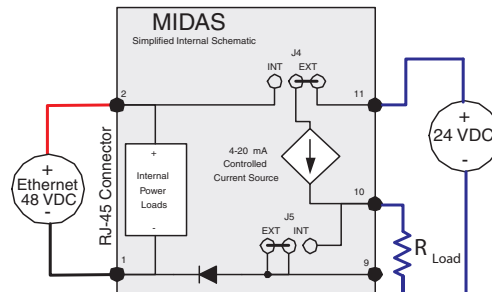

Honeywell

Midas[®] Gas Detector

Diagram 4-11. Midas[®] to 5701 4-Wire Isolated Connection

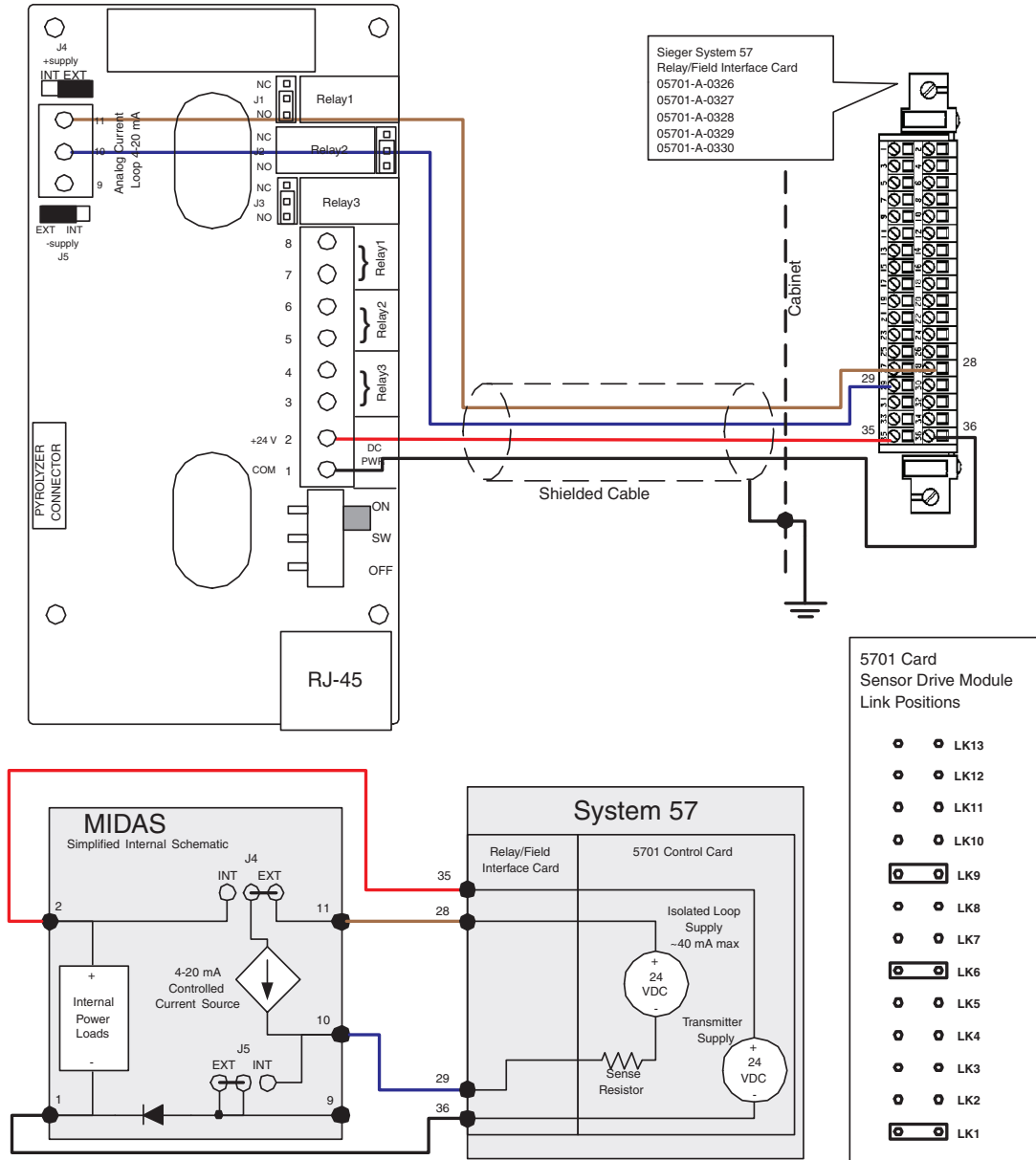

Honeywell

Midas® Gas Detector

Diagram 4-12. Midas® to 5701 3-Wire Sourcing Connection

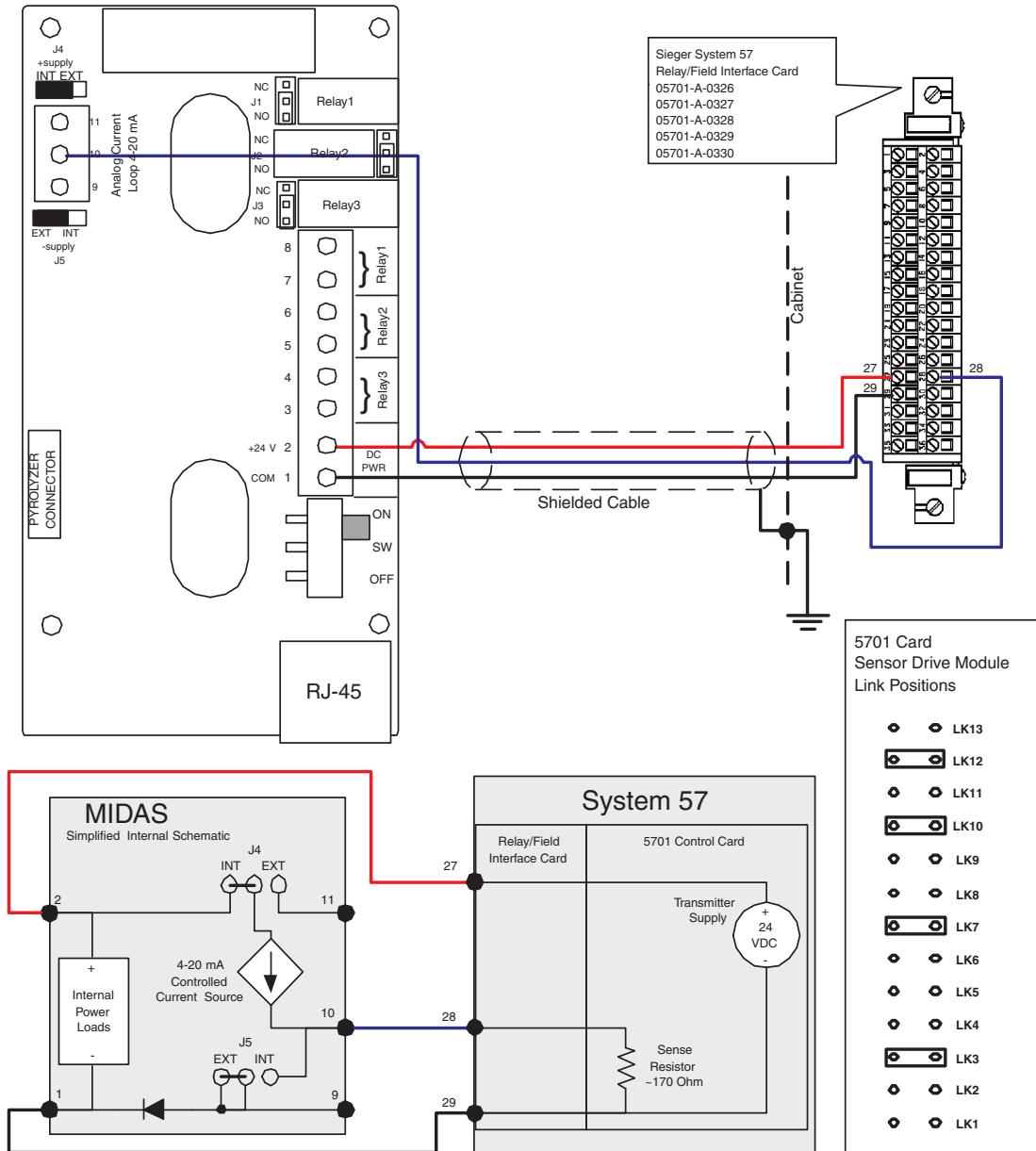

Honeywell

Midas® Gas Detector

Diagram 4-13. Midas® to 5701 3-Wire Sinking Connection

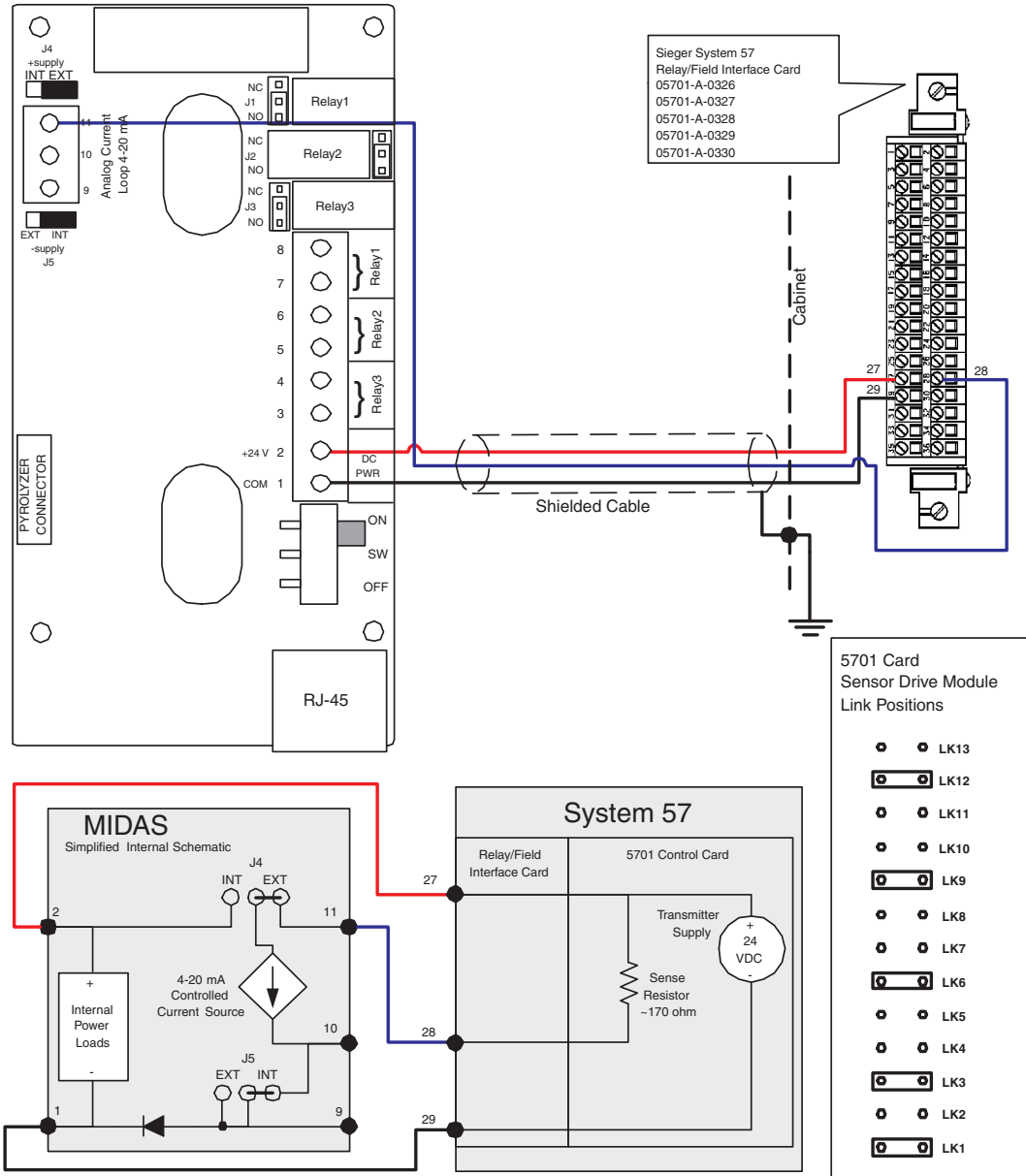

Honeywell

Midas[®] Gas Detector

Diagram 4-14. Midas[®] to 5704 4-Wire Connection

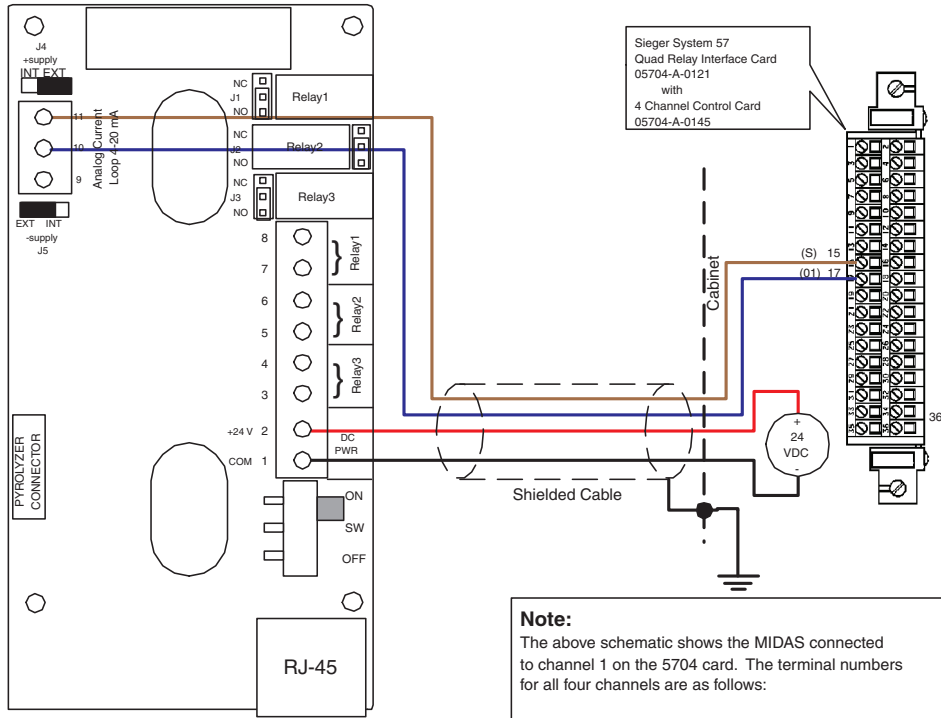

Note:

The above schematic shows the MIDAS connected to channel 1 on the 5704 card. The terminal numbers for all four channels are as follows:

MIDAS Function	Loop +	Loop -
Midas Terminal Number	11	10
System 57 Function	S	01
Color in this figure	Brown	Blue
5704 Channel 1 Terminal	15	17
5704 Channel 2 Terminal	16	18
5704 Channel 3 Terminal	21	23
5704 Channel 4 Terminal	22	24

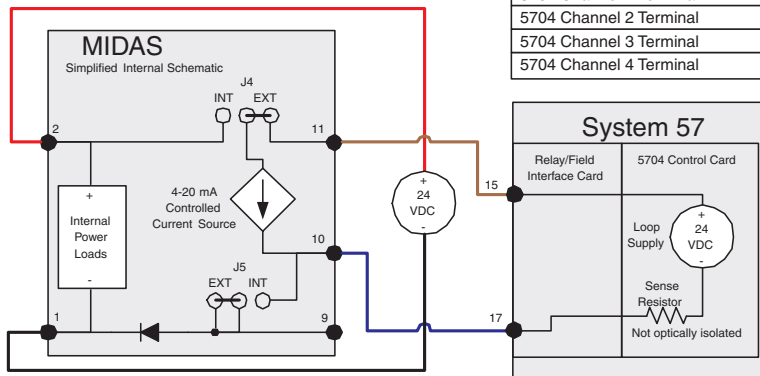

Honeywell

Midas[®] Gas Detector

Diagram 4-15. Midas[®] to 5704 3-Wire Sourcing Connection

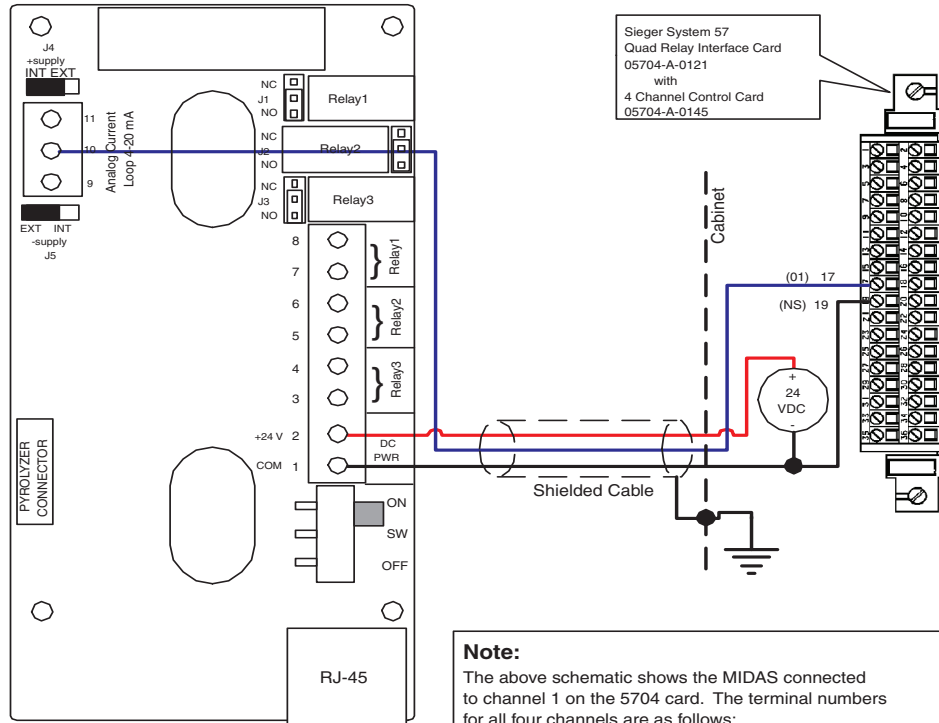

Note:

The above schematic shows the MIDAS connected to channel 1 on the 5704 card. The terminal numbers for all four channels are as follows:

MIDAS Function	Analog Out	Common
Midas Terminal Number	10	1
System 57 Function	01	NS
Color in this figure	Blue	Black
5704 Channel 1 Terminal	17	19
5704 Channel 2 Terminal	18	20
5704 Channel 3 Terminal	23	25
5704 Channel 4 Terminal	24	26

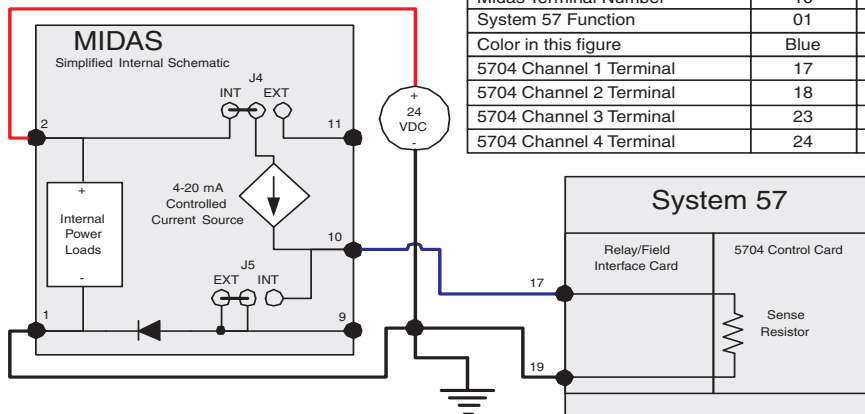

Honeywell

Midas® Gas Detector

Diagram 4-16. Midas® to Touchpoint1 4-Wire Connection

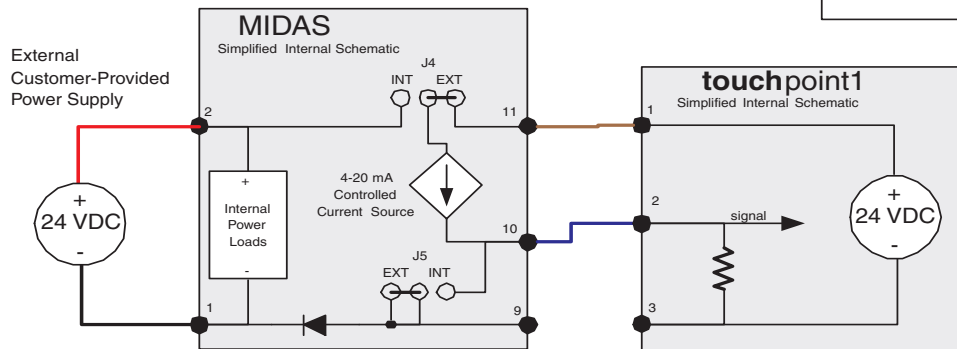
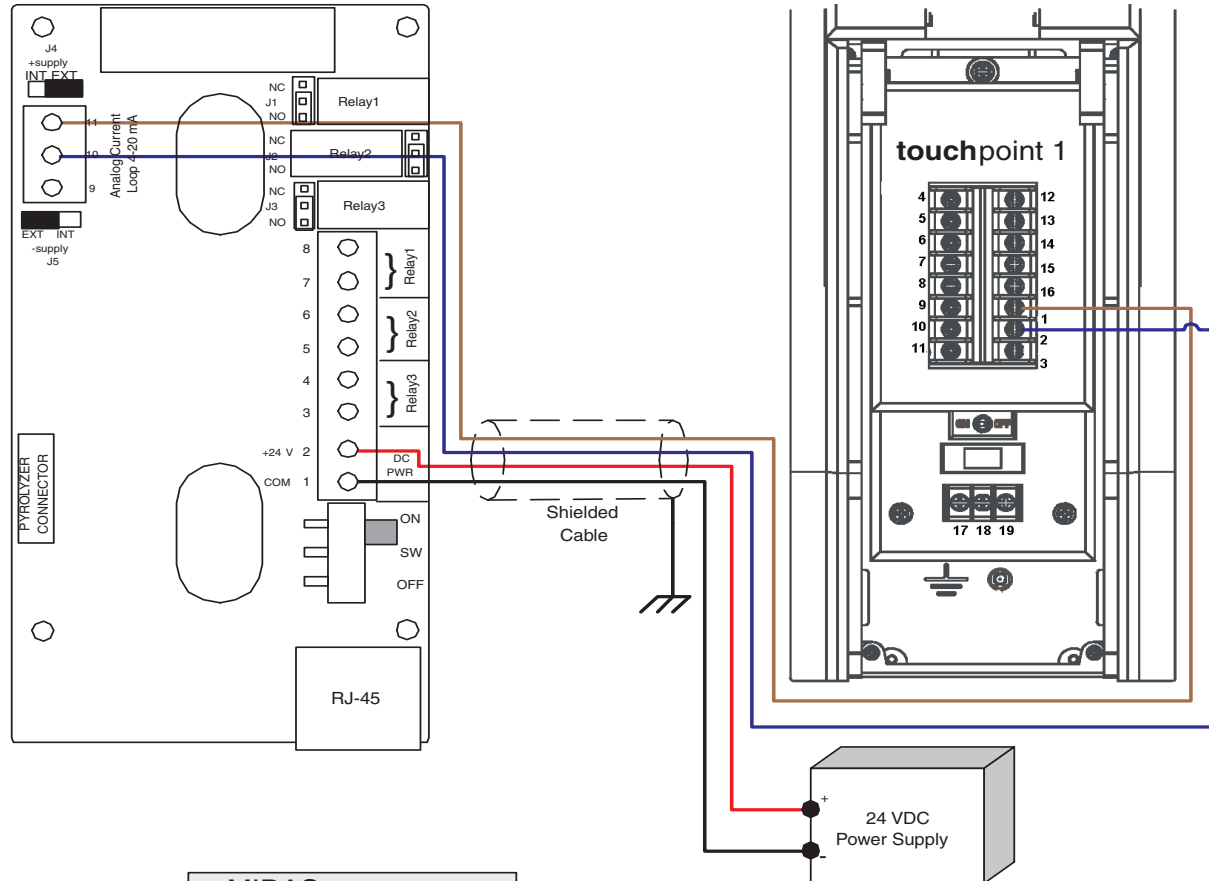

Honeywell

Midas® Gas Detector

Diagram 4-17. Midas® to Touchpoint1 3-Wire Sourcing Connection

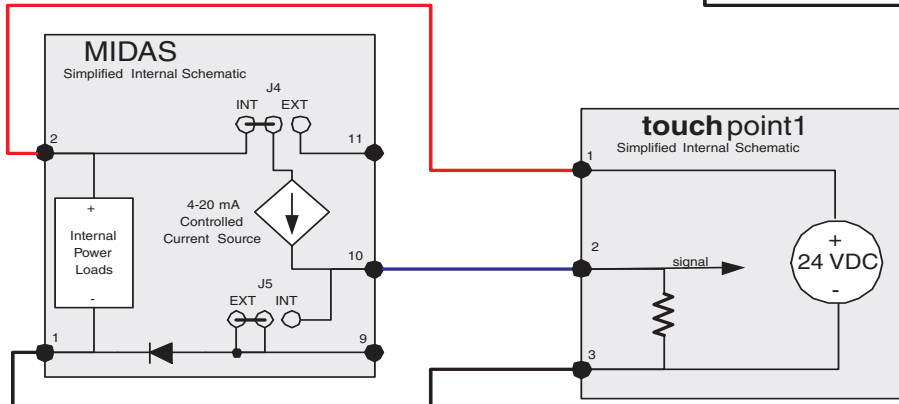
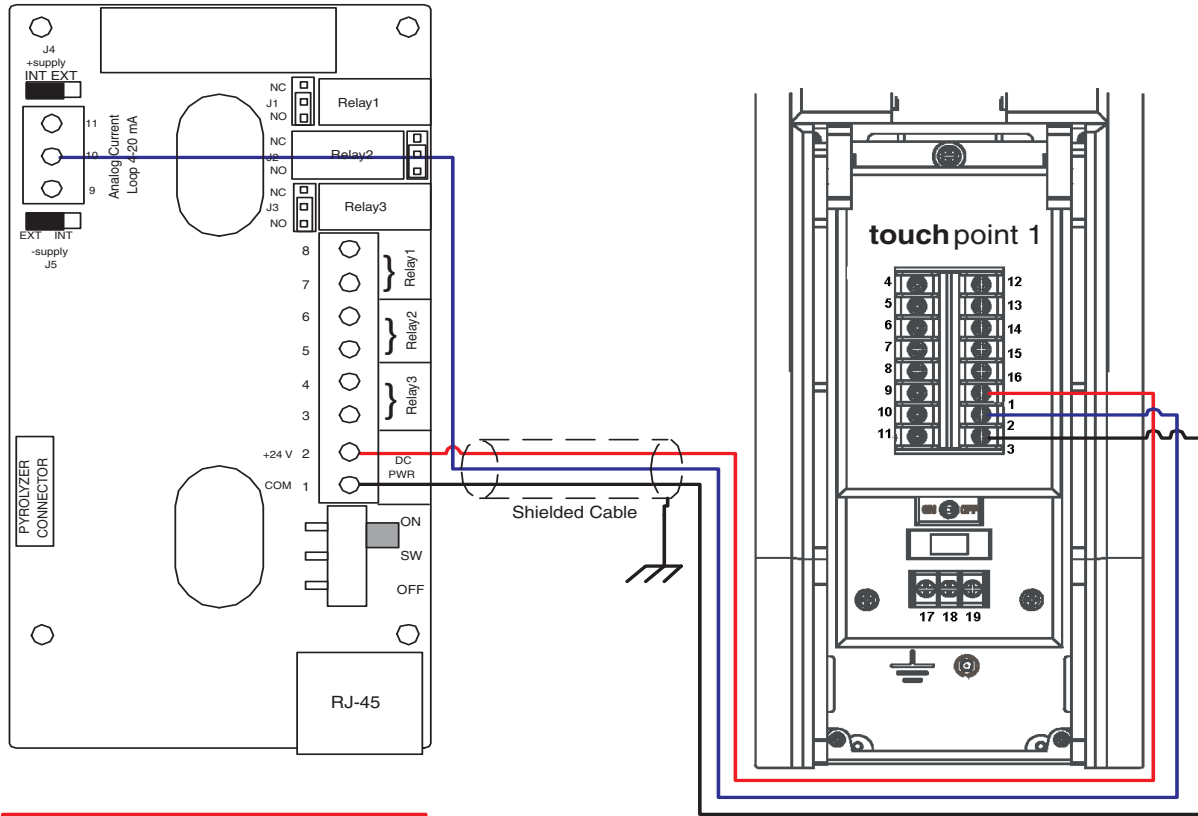

Honeywell

Midas® Gas Detector

Diagram 4-18. Midas® to HA71 3-Wire Sourcing Connection

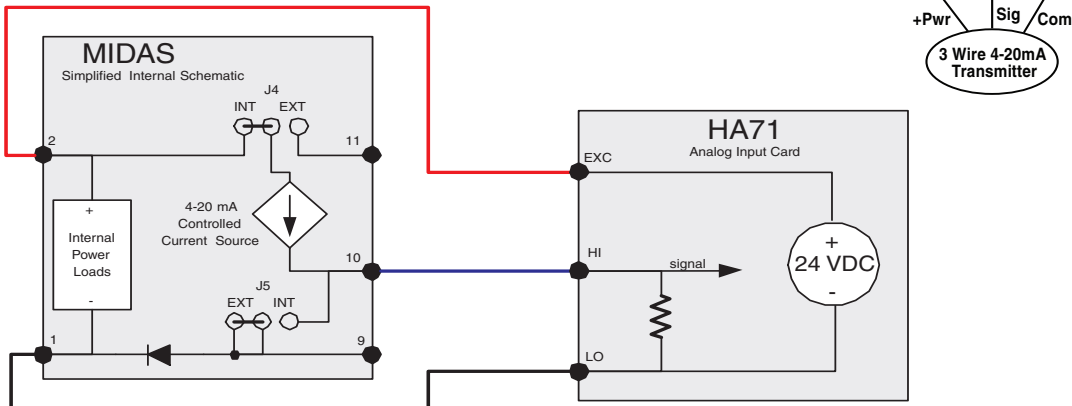
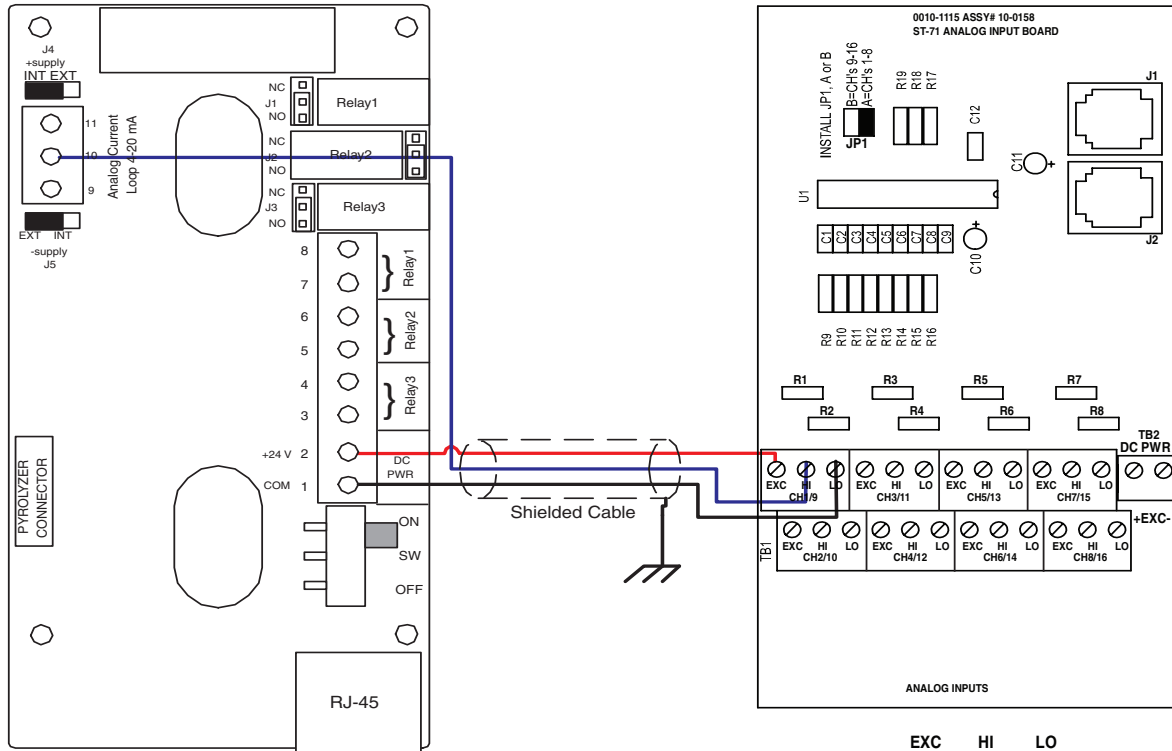

Honeywell

Midas[®] Gas Detector

Diagram 4-19. Midas[®] to HA71 4-Wire Connection

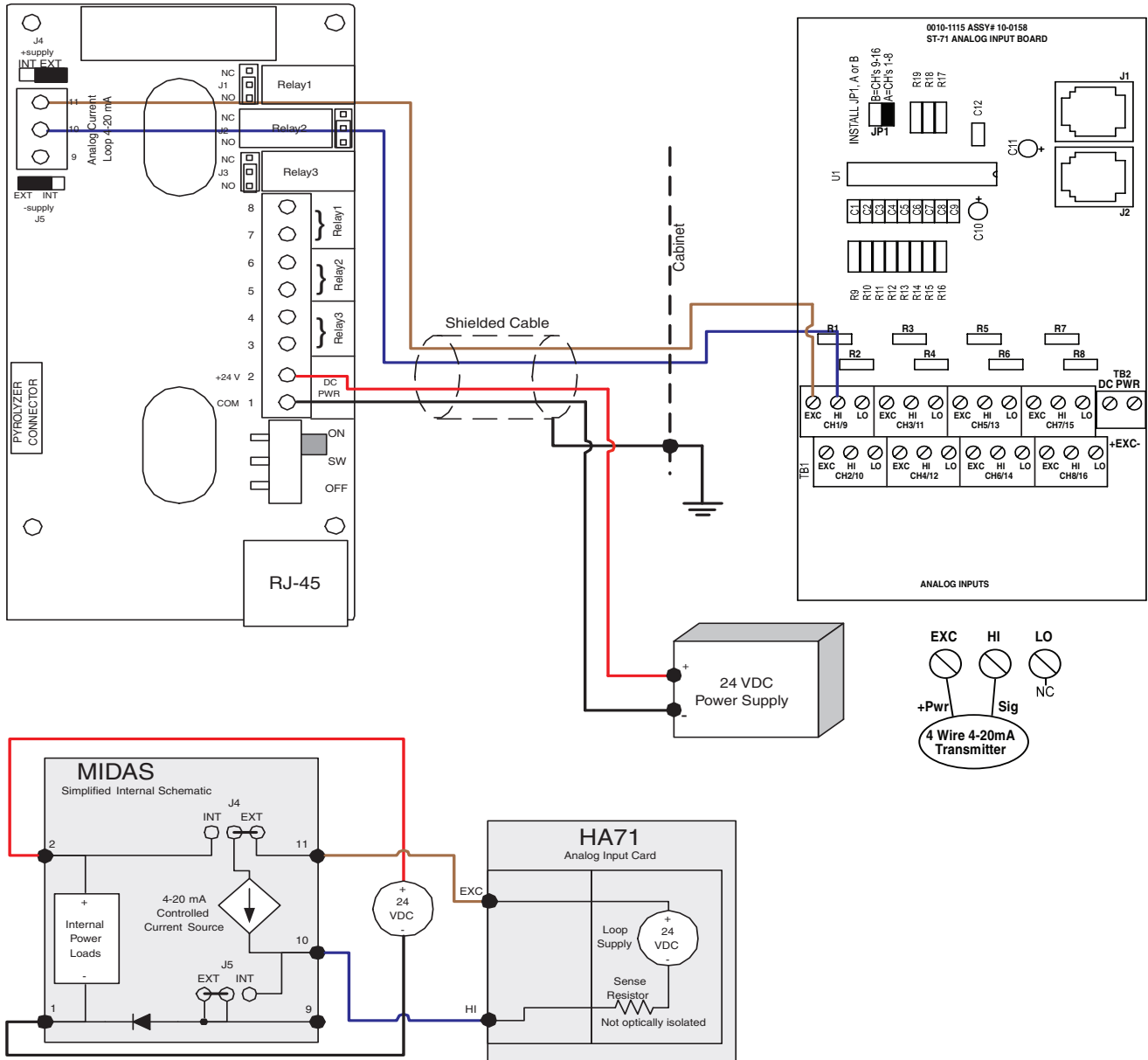

Honeywell

Midas® Gas Detector

Diagram 4-20. Midas® to Touchpoint4 4-Wire Connection

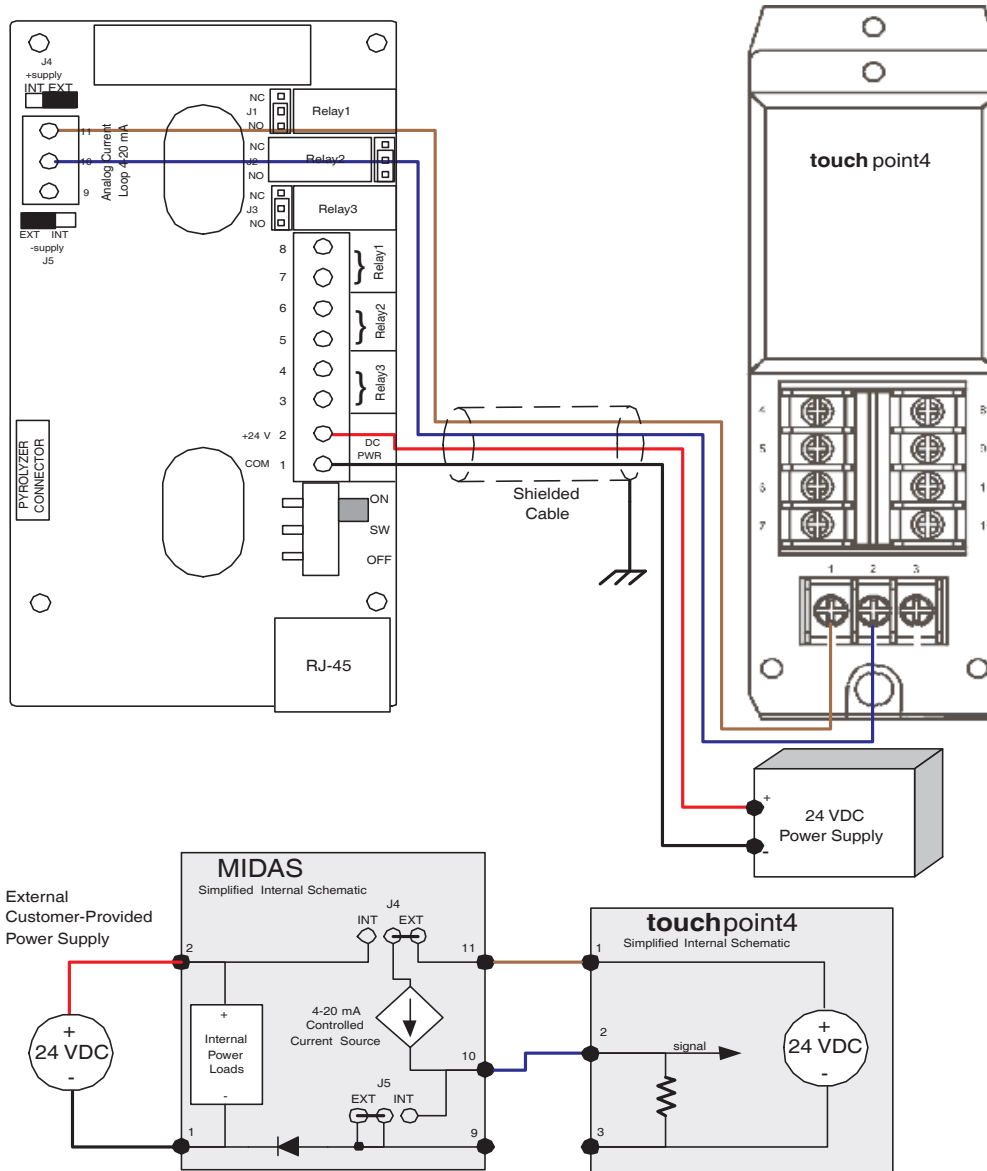

Honeywell

Midas® Gas Detector

Diagram 4-21. Midas® to Touchpoint4 3-Wire Sourcing Connection

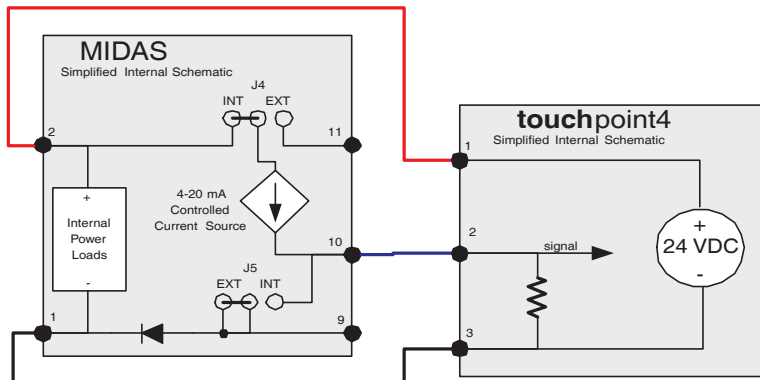
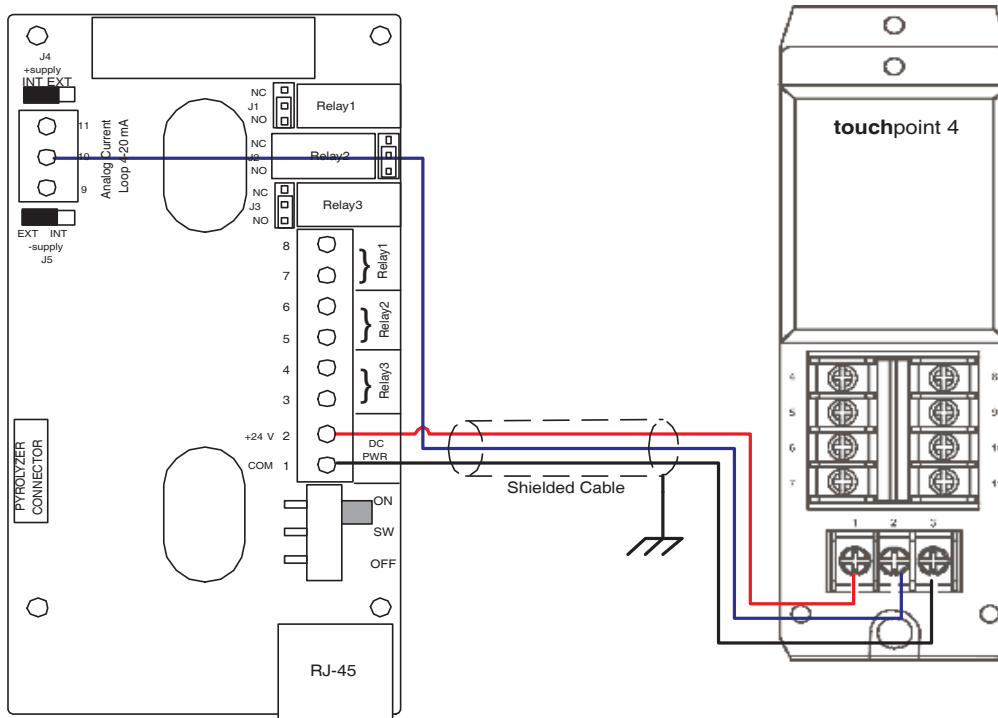

Honeywell

Midas® Gas Detector

4.8 Refitting the Main Chassis

The main chassis can be refitted to the mounting bracket assembly using the following steps.

1. Align the PCB at the top rear of the main chassis with the connector located at the top of the mounting bracket assembly
2. At the same time align the two tubes at the bottom rear of the main chassis with the two tubes located on the bottom of the mounting bracket assembly.
3. Slide the chassis backwards on the mounting bracket assembly so that the PCB and connector and tubes engage simultaneously. (See diagram below).
4. Ensure the PCB, connector and tubes are fully engaged by firmly pushing the main chassis horizontally backward on the mounting bracket assembly (WARNING: DO NOT PUSH ON THE LCD AS THIS MAY CAUSE DAMAGE).
5. Align the two attaching screws located at the bottom of the chassis with the screw threads on the mounting bracket assembly.
6. Tighten the screws to secure the chassis to the mounting bracket assembly.

Diagram 4-20. Refitting the chassis.

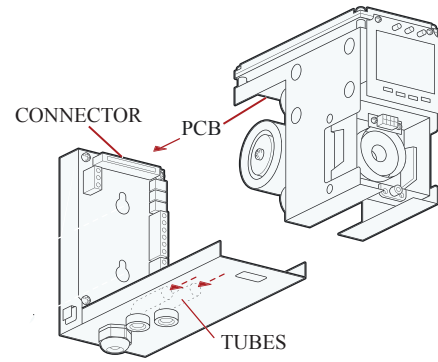

4.9 Installing the Sensor Cartridge

The Midas® sensor cartridge is supplied separately and needs to be fitted to the detector's main chassis. The following steps and diagrams detail the procedure for installing the sensor cartridge for the first time. This procedure is carried out with the power off and the detector cover removed.

1. Verify the part number and type of sensor cartridge is correct for your application, then remove sensor cartridge from its packaging.

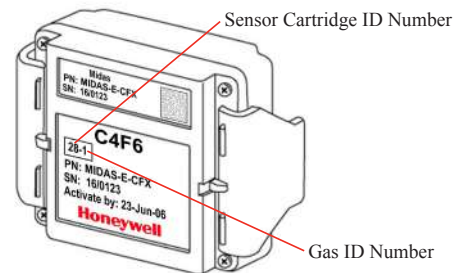

2. Remove cap from cartridge and bias battery (if applicable).
3. Add label for secondary gases (if necessary).
4. Align pins at the top of the sensor cartridge with the socket in the sensor cartridge chamber.

Honeywell

Midas® Gas Detector

5. Carefully push the sensor cartridge into the sensor cartridge chamber until fully seated.
6. Lock the sensor cartridge in place using the tabs on either side of the sensor cartridge to secure the cartridge to the main chassis.
7. Switch the power switch on the terminal module to the 'on' position.
8. Reattach the detector cover by aligning the slots on either side with the locating tabs on the mounting bracket assembly.
9. Push the cover horizontally until fully seated.
10. Tighten the thumbscrew on the front panel.

Diagram 4-21. Installing the sensor cartridge

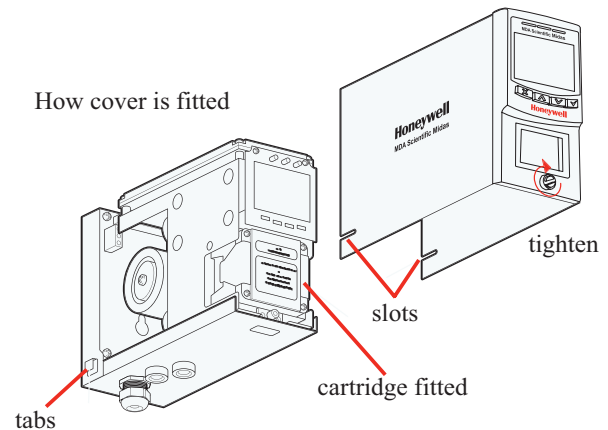
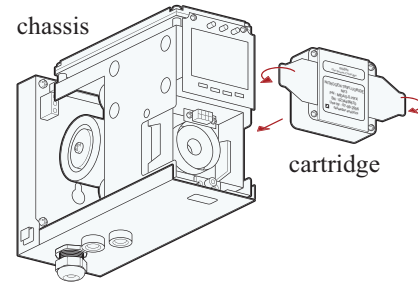

Caution

When refitting the cover to the Midas® unit, use caution to prevent damage to the RFI shielding tabs attached to the chassis.

5 Startup

5 Startup

WARNING

Prior to carrying out any work ensure local and site procedures are followed. Ensure that the associated control panel is inhibited so as to prevent false alarms.

The following procedure should be followed carefully and only performed by suitably trained personnel.

1. Ensure the detector is wired correctly according to [Sections 4.6](#) and [4.7](#).
2. Ensure that the correct sensor cartridge is fitted. (If the cartridge has not been stored at room temperature, allow one hour for equilibration.)
3. Ensure the on/off switch on the mounting bracket assembly is in the on position.
4. Apply power to the system.
5. After the startup routine the detector will display normal operating mode as shown in [Section 6](#).
6. Perform a leak test as shown in [Section 8.5](#) to ensure all connections are secure.
6. If using a multi gas sensor cartridge refer to [Section 7.2.2](#) to ensure the correct gas ID code is selected.
7. Allow the detector to stabilize until the 'WArm' message is no longer displayed. The maximum warm up time is listed in Appendix B. Warm-up times are typically much faster.
8. If this is a first-time startup, an F49 or F88 fault code may be displayed; there is no actual fault and the fault message can

be cleared by depressing the 'X' cancel button for 2 seconds.

To properly activate the Midas® with a cartridge for the first time:

- When 'Change Gas' scrolls on the display, hit the '✓' on the Midas® front panel.
- When the 'reboot' completes then press and hold the 'X' to clear any latched fault(s).
- If "FlrSt CELL" is displayed, press '✓'.

The cartridge has now been accepted by the Midas® as the correct type to be used.

Honeywell

Midas[®] Gas Detector

6 Operation

6 Operation

After applying power to the detector, the display will go through a startup test routine illuminating in sequence all the LEDs, icons and digits of the display. The display will show the message 'WAIT' and 'LoAd' as it checks for cartridge data, typically less than 180 seconds. It will then display the message 'WArM' until the sensor cartridge reaches operating temperature. When complete, the detector will enter normal monitoring mode indicated by the '🌀' icon on the display cycling through three states (2 rings, 3 rings, 4 rings). The measured gas concentration will be shown on the display. The green LED will flash once every second indicating power and the sample flow rate indicator will be displayed. If monitoring is interrupted due to a fault, a test or calibration process or a user requested inhibit, the display will flash. For details of fault and maintenance fault codes refer to Section 11.

Note

The first time the Midas® is started with a new sensor cartridge, an F49 or F88 fault code may be displayed; there is no actual fault and the fault message can be cleared by depressing the 'X' cancel button for two seconds.

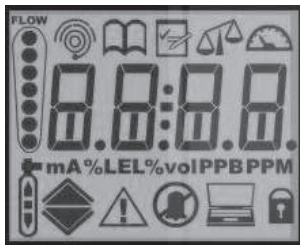

Final Start Up Routine Screen

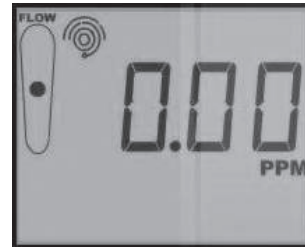

Normal Operation

6.1 Normal Operation Mode 🌀

In this mode the detector displays gas concentration, alarm, fault and status information via its backlit LCD and front panel LEDs. Typical normal operation display and output states are shown below. See Section 11 for a full list of fault codes.





Note:

The examples in Table 6-1 are for a linear 4-20 mA output over a full scale range of 2 ppm. The current output for a given gas concentration will be different for other full scale ranges (linear 4 mA = 0 % full scale to 20 mA = 100 % full scale). The alarm and fault relays are in default (latching) mode.

Honeywell

Midas® Gas Detector

Table 6-1. Normal operation display and output states.

Operational State	Relay status	4-20 mA output (for 2ppm range)	LEDs	Backlight		Display
				Classic Mode	Multi Color Mode	
Alarm 2	Alarm relay 1 activated (common case) Alarm relay 2 activated Fault relay activated	8 mA (proportionate to concentration)	Green flash Red flash	Green	Red flash White flash	
Greater than full scale	Alarm relay 1 activated Alarm relay 2 activated Fault relay activated	21 mA	Green flash Red flash	Green	White flash Yellow flash	
Inhibit	Alarm relay 1 de-activated Alarm relay 2 de-activated Fault relay activated	2 mA	Green flash	Green	Green	
Low flow rate	Alarm relay 1 de-activated Alarm relay 2 de-activated Fault relay activated	3 mA	Green flash Yellow on	Green	Yellow	
Low flow fault	Alarm relay 1 de-activated Alarm relay 2 de-activated Fault relay de-activated	1 mA	Green flash Yellow flash	Green	White flash Yellow flash	

6.1.1 Resetting Alarms, and Faults

The alarm function of Midas® can be set to latching (See Section 7.2.1) so that when an alarm occurs the associated outputs remain activated even if the gas reading has dropped below the alarm level. To reset the latched alarm press the 'X' cancel button for 2 seconds. If the gas level is still above the alarm point you can reset the associated relay but it will activate again after the elapse of any alarm on delay that has been set.

If the alarm function is set to non-latching, the display will automatically clear when the alarm condition is cleared.

The fault function can also be set to latching. It can be reset by pressing the 'X' cancel button for 2 seconds. If the fault conditions persist, the fault will be reappear quickly.

If the fault operation is set to non-latching, the display will automatically clear when the fault condition is cleared.

6.2 Review Mode

The detector settings can be reviewed safely without the possibility to make changes by using review mode. To select review mode press the '▲' up or '▼' down button once. The review mode icon  will show on the display and the first review mode menu icon is displayed.

6.2.1 Review Mode Menu Overview

The menu is simply navigated by using the '▲' up and '▼' down buttons to select the required menu, and then using the '✓' accept button to enter that submenu and scroll through to view the settings. The 'X' cancel button can be used to exit the submenu



and allow selection of a different submenu, or can be pressed again to exit to normal operating mode. When in review mode the unit will automatically return to the main normal operation status display if either an alarm level is exceeded or no button is pressed for 60 seconds.

Table 6-2 shows an overview of the different review menus and how they are navigated. For a detailed step-by-step instruction of how to review the detector setting in review mode refer to Section 7.1.

Honeywell

Midas® Gas Detector

Table 6-2. Review menu overview.

Display	Screen 1	Screen 2	Screen 3	Screen 4	Screen 5	Screen 6	Screen 7	Screen 8	Screen 9	Screen 10
Software SW	Transmitter software revision	Checksum	Password key 1	Password key 2						
Alarms ALm 	Gas Selection	Alarm 1 direction: U: rising d: falling	Alarm 1 threshold	Alarm 2 direction: U: rising d: falling	Alarm 2 threshold	Alarm delay time	Alarm latching	Alarm relays normally energized/de-energized		
4-20 mA Output mA	4 mA	gas corresponding to 4 mA	20 mA	gas corresponding to 20 mA						
Faults FLt 	Fault relay configuration Year	Faults latching/non-latching	Fault relays normally energized/de-energized	Fault m12 occurrence frequency	m15 and F80 enable/disable					
Calibration CAL 	Days to calibration due	Days to cartridge expire	Year of last calibration	Month and day of last calibration						
Date/Time tImE		Month - Day								
Address nEt 	Shows web access level	Use DHCP server for IP parameters	IP address byte 1	IP address byte 2	IP address byte 3	IP address byte 4	Subnet mask byte 1	Subnet mask byte 2	Subnet mask byte 3	Subnet mask byte 4
Event Log hiSt  	Date of latest event	Time of latest event	Description of latest event	Date of second latest event	Time of second event	Description of second event	Repeat for events 3-7, 3 Displays per			
LCD	Shows LCD Backlight Mode									

6.3 Overview of Set-up, Calibration, and Test Mode

WARNING



Set-up, calibration and test modes are intended for use by trained personnel or service engineers only. Access to these modes can be pass code protected by following the procedure in Section 7.2.7.

Set-up, calibration and test modes are used to make setting changes, calibrate and test the detector. To select set-up, calibration and test mode press and hold the '▲' up button or '▼' down button for one second. The unit will automatically go to the main normal operation status display from setup/calibration/test menus (but not from inside a setup/calibration/test function) if no button is pressed for 5 minutes or if an alarm level is exceeded.

PASS CODE: If a pass code has been set the display will show 0000 with the first 0 flashing. Use the '▲' up or '▼' down buttons to set the first digit of the pass code. Press '✓' to enter the first digit. The second digit will then flash. Repeat the process until all four pass code digits have been entered. Please record your pass code in a separate archive that can be securely retrieved. Failure to be able to retrieve your pass code may lead to delays in gaining access to all the protected functions in each Midas® unit. If an incorrect code is entered the display will show 'Err' and return to the normal operation mode. If a pass code is forgotten contact your local Honeywell Analytics service department.

After successfully entering the pass code (if set) the first menu  SET' set-up icon will show on the

display.

The  CAL' calibration or  tEST' test menu can also be selected using the '▲' up or '▼' down buttons. Press the '✓' accept button to enter the selected menu or the 'X' cancel button to return to normal operation mode.

6.3.1 Set-up Menu Overview

The set-up menu allows changes to be made to the detector alarm, fault, calibration interval, date/time and digital address settings. The menu is navigated using the '▲' up and '▼' down buttons to select the required submenu and then using '✓' accept button to enter that submenu. The '▲' up and '▼' down buttons are used to make changes to the selected setting and are confirmed using the '✓' accept button. The 'X' cancel button can be used to exit the submenu and allow selection of a different submenu, or can be pressed again to exit to the main set-up, calibration and test menu. Pressing the 'X' cancel button again returns the detector to normal operating mode.

Note

All settings in a submenu are accepted when the '✓' accept button is pressed after the last submenu setting. This saves the changes and is indicated by displaying 'UPdt' on the LCD. If however the 'X' cancel button is pressed at any time before the changes are accepted, this will cause any changes to be cancelled in that particular submenu.

Table 6-3 shows an overview of the set-up submenus and how they are navigated. For a detailed step-by-step instruction of how to change the detector settings using the set-up menu refer to Section 7.2.

Honeywell

Midas® Gas Detector

Table 6-3. Set-up menu overview.

Display	Screen 1	Screen 2	Screen 3	Screen 4	Screen 5	Screen 6	Screen 7	Screen 8	Screen 9	Screen 10
Alarms ALm	Change gas ID for multi-gas sensors	Set alarm 1 direction: U: rising d: falling	Set alarm 1 threshold	Set alarm 2 direction: U: rising d: falling	Set alarm 2 threshold	Set alarm delay time	Set alarm latching	Set alarm relays normally energized/ de-energized		
4-20 mA Output mA	4 mA	Gas corresponding to 4 mA	20 mA	Gas corresponding to 20 mA						
Faults FLt	Set Set fault relay config: (1FLt, 2FLt, CmbF or nEtr)	Set fault latching/ non-latching	Set fault relays normally energized/ de-energized	Set fault m12 occurrence freq: 1m12:once Wm12: wkly 0m12: never	Set m15 and F80 enable/ disable					
Calibration CAL	calibration interval (MIDAS-S 0-365 days, MIDAS-E 0-730 days 0 = off)*		mm	dd	hh	mm				
Date/Time timE	Set date format: dd:mm or mm:dd	Set year: yyyy (2003-2030)	Set month: (01-12)	Set Day: (01-31)	Set hour: (00-23)	Set minute: (00-59)				
Address nEt	Set Web Access: WA Y: full access WA n: read only	Set Auto or Manual address: AU Y: DHCP AU n: man	Manual IP address byte 1	Manual IP address byte 2	Manual IP address byte 3	Manual IP address byte 4	Manual Subnet mask byte 1	Manual Subnet mask byte 2	Manual Subnet mask byte 3	Manual Subnet mask byte 4
Set Pass Code PWd	Press ▲ or ▼ to set pass code digit 1	Press ▲ or ▼ to set pass code digit 2	Press ▲ or ▼ to set pass code digit 3	Press ▲ or ▼ to set pass code digit 4	Press ▲ or ▼ to confirm pass code digit 1	Press ▲ or ▼ to confirm pass code digit 2	Press ▲ or ▼ to confirm pass code digit 3	Press ▲ or ▼ to confirm pass code digit 4		
LCD	Set backlight mode bm: C(classic mode) or bm: m (multi color mode)									
PUMP	Set pump control frequency									

* MIDAS-E-LEL 0-1825 days

6.3.2 Calibration Menu Overview ‘CAL’



The calibration menu allows calibration of the detector zero, span, flow and 4-20 mA. The menu is simply navigated using the ‘▲’ up and ‘▼’ down buttons to select the required submenu and then using ‘✓’ accept button to enter that submenu. The ‘▲’ up and ‘▼’ down buttons are used to make any changes to a selected setting and are confirmed using the ‘✓’ accept button. The ‘X’ cancel button can be used to exit the submenu and allow selection of a different submenu, or can be pressed again to exit to the main set-up, calibration and test menu. Pressing the ‘X’ cancel button again returns the detector to normal operating mode.

The table below shows an overview of the calibration submenus and how they are navigated. For a detailed step-by-step instruction of how to change the detector calibration settings refer to Section 7.2.

Honeywell

Midas® Gas Detector

Table 6-4. Calibration menu overview.

Display	Screen 1	Screen 2	Screen 3	Screen 4	Screen 5	Screen 6	Screen 7	Screen 8
Zero OCAL 	Icon flashes alerting user to prepare to apply zero gas	Unit is zeroing	PASS is displayed if OK, fault code displayed if not.	Select inhibit state after exiting zero cal menu Inh Y: set full inhibit Inh N: keep initial inhibit state	Set inhibit timeout. Set range is 00 (hour):00 (minute_) to 4:00. Default is 30 minutes.			
Span SPAn 	Set gas ID code of calibration for multi-gas sensors only	Select if humidified: HUm or dry: drY calibration gas	Adjust value to display span gas concentration used	Display steadies and displays span gas reading, dots indicate progress. PASS is displayed if OK, fault code displays if not.	Set purging time. Set range is 0 min to 99 min. Default is 3 min.	Remaining purging time in second is displayed.	Select inhibit state after exiting cal menu Inh Y : set full inhibit Inh n : keep initial inhibit state	Set inhibit timeout. Set range is 00(hour):00 (minute) to 4:00. Default is 30 minutes.
Flow FLOW 	Icon flashes, display shows 0 indicating flow zero will be set.	Unit counts down from 10 to 0 and sets flow zero. Display shows 1st set point target flow rate. Use ▲ or ▼ to make reading on external flow meter +/- 50cc/min of set point 1	Use ▲ or ▼ to change the flashing display to the actual reading from the external flow meter	Unit counts down from 10 to 0 and sets 1st set point. Icon flashes and displays 2nd set point target. Repeat process to set.				
4-20 mA 4-20 mA	4 mA is displayed indicating analog output should be 4 mA	Adjust until analog output is 4 mA Verify output with meter	20 mA is displayed indicating analog output should be 20 mA	Adjust until analog output is 20 mA Verify output with meter				

Honeywell

Midas® Gas Detector

6.3.3 Test Menu Overview ‘ tEST’

The test menu is used to test the detector gas reading using bump test gas, and for simulation of alarm and fault display and output operation. The test menu also contains the detector Inhibit facility. Use the ‘▲’ up and ‘▼’ down buttons to select either bump test or alarm/fault test. Press the ‘✓’ accept button to enter that submenu.



The table below shows an overview of the test submenus and how they are navigated. For a detailed step-by-step instruction of how to test the detector operation refer to Section 7.2.

Note

In bump test mode, the Modbus/TCP outputs are not inhibited. Only the 4-20mA and alarm outputs are inhibited.

The bump gas test is a functional check only. Consult local guidelines for recommended best practices. Bump test concentrations recommended in Appendix B are calculated to generate a minimum first alarm level response.

Table 6-5. Test Submenu

Display	Screen 1	Screen 2	Screen 3	Screen 4
Bump bUmP 	Apply bump test gas and display shows measured gas concentration with all alarm outputs inhibited	Press ‘X’ to exit to test menu		
Alarm/ fault Sim 	Display shows ‘Sim’ and the A1 ‘▲’ symbol. 4 states: ▲: alm 1 ▲: alm 2 ▲ flashing: inst fit ▲: maint fit	Display shows ‘SuRE’.	Display flashes ‘Sim’ and simulates the selected A1, A2 or Fault display and output.	Press ‘X’ to exit and select another simulation or ‘X’ again to return to test submenu
Inhibit Inh 	Press ▲ or ▼ to select ALm, ALm-Ft, ALL or nonE inhibit state	Set inhibit timeout period	UPdt is displayed and unit enters selected inhibit state. Display returns to submenu	
4-20 mA 4-20 mA	Display shows ‘S XX’ where XX is the mA value Press ▲ or ▼ for the desired mA output			

7 Navigating Modes and Submenus





7 Navigating Modes and Sub-menus

The following sections provide step-by-step procedures for navigating all the modes and submenus.

7.1 Review Mode

Review mode allows the settings of the detector to be reviewed safely without any changes being made. Review mode consists of 9 submenus:

Table 7-1. Review mode submenus.

Review submenu	Icon	Settings Displayed
Software	SW	Revision and checksum
Alarms		Sensor cartridge and gas ID codes, alarm 1 and alarm 2 configuration and set points, time delay, latching/non latching, energized/de-energized
4-20 mA output	mA	4 mA, gas conc. corresponding to 4 mA; 20 mA, gas conc. corresponding to 20 mA
Faults		Configuration, Latching/non latching, energized/de-energized, temperature fault enable/disable
Calibration		Days left to next calibration due and date of last calibration
Time/Date	timE	Current year, date and time
IP address		Auto address selection on/off, IP address, sub net mask values.
Event log		View the date, time and details of the last seven alarm, fault and maintenance fault events
LCD	LCD	LCD backlight mode

To select review mode from normal operation, press the ‘▲’ up or ‘▼’ down button once. The  icon will be displayed along with the first submenu icon. Press the ‘▲’ up or ‘▼’ down buttons to select a different submenu icon.

7.1.1 Review Software ‘SW’

1. Select the software ‘SW’ submenu and press ‘✓’ to accept.
2. The software version number is displayed.
3. Press ‘✓’ to display the software checksum
4. Press ‘✓’ to display the password key 1.
5. Press ‘✓’ to display the password key 2.
6. Press ‘✓’ to return to step 1.
7. Repeat steps 1 through 4 to view the information again or press ‘▲’ up or ‘▼’ down to select another submenu.
8. Press ‘X’ to return to normal operation

7.1.2 Review Alarms ‘ ALm’

1. Select the alarms ‘ Alm’ submenu and press ‘✓’ to accept.
2. The sensor cartridge ID (X) and the set gas ID code (Y) are displayed in the format (X – Y). (See Appendix B for a list of sensor cartridge and gas ID codes).
3. Press ‘✓’ to display if the level 1 alarm (L1) type is rising (U) or falling (d).
4. Press ‘✓’ to display the alarm 1 value along with the A1 icon ‘▲’.
5. Press ‘✓’ to display if the level 2 alarm (L2) type is rising (U) or falling (d).
6. Press ‘✓’ to display the alarm 2 value along with the A2 icon ‘▲’.
7. Press ‘✓’ to display the alarm on delay (seconds).
8. Press ‘✓’ to display if the alarm output is set to latching (L) or non latching (nL).
9. Press ‘✓’ to display if the alarm relays are set to normally energized (nE) or normally de-energized (nd).
10. Press ‘✓’ to return to step 1.
11. Repeat steps 1 through 7 to view the settings again or press ‘▲’ up or ‘▼’ down to select another submenu.
12. Press ‘X’ to return to normal operation.

7.1.3 Review 4-20 mA Output “mA”

1. Select the 4-20mA ‘mA’ submenu and press ‘✓’ to accept. ‘4 mA’ will be displayed
2. Press ‘✓’ to display the gas conc. corresponding to 4 mA. ‘20 mA’ will be displayed.
3. Press ‘✓’ to display the gas conc. corresponding to 20 mA.
4. Press ‘✓’ to return to step 1.
5. Repeat steps 1 through 5 to view the settings again or press ‘▲’ up or ‘▼’ down to select another submenu
6. Press ‘X’ to return to normal operation

7.1.4 Review Faults ‘ FLT’

1. Select the faults ‘ FLT’ submenu and press ‘✓’ to accept.
2. The fault relay configuration (1FLt, 2 FLt, CmbF, or nEtr) is displayed. (See [Section 7.2.3](#) for details of fault relay configurations).
3. The fault output latching (L) or non latching (nL) setting is displayed.
4. Press ‘✓’ to display the fault relay normally energized (nE) or normally de-energized (nd) setting.
5. Temperature fault m15 and F80 enable (Y) or disable (n) setting is displayed.
6. Press ‘✓’ to return to step 1.
7. Repeat steps 1 through 5 to view the settings again or press ‘▲’ up or ‘▼’ down to select another submenu.
8. Press ‘X’ to return to normal operation.

7.1.5 Review Calibration 'CAL'

1. Select the review calibration 'CAL' submenu and press '✓' to accept.
2. The number of days remaining to the next calibration due date is displayed. If the number of days is set to zero then no further reminders will be displayed.
3. Press '✓' to display the number of days until cartridge expiration.
4. Press '✓' to display the year and press '✓' again to display the month and day of the last calibration.
5. Press '✓' to return to step 1.
6. Repeat steps 1 through 4 to view the settings again or press '▲' up or '▼' down to select another submenu.
7. Press 'X' to return to normal operation.

7.1.6 Review Date and Time 'timE'

Select the review date and time 'timE' submenu and press '✓' to accept.

1. The current year setting is displayed.
2. Press '✓' to display the current month and day.
3. Press '✓' again to display the current time.
4. Press '✓' to return to step 1.
5. Repeat steps 1 through 5 to view the settings again or press '▲' up or '▼' down to select another submenu.
6. Press 'X' to return to normal operation.

7.1.7 Review Detector Address ‘☒ nEt’

1. Select the review address ‘☒ nEt’ submenu and press ‘✓’ to accept.
2. ‘WA Y’ or ‘WA n’ is displayed depending on whether full web access or read only has been selected.
3. ‘AU Y’ or ‘AU n’ is displayed depending on if auto address detection is on (AU Y) or off (AU n).
4. Press ‘✓’ to display the first part of the IP address preceded by the letter ‘A’.
5. The dot on the upper left indicates that the first part of the IP address is being displayed.
6. Press ‘✓’ to display the second part of the address. The two dots on the upper left indicate the 2nd portion of the address.
7. Press ‘✓’ again to display the third part and again to display the last part of the address.
8. Press ‘✓’ and the first part of the sub net mask values will be displayed preceded by the letter ‘n’.
9. Press ‘✓’ to scroll through the second, third and forth sub net values. The number of dots in the upper left indicate which part of the sub net address is being viewed.
10. Press ‘✓’ to return to step 1.
11. Repeat steps 1 through 9 to view the settings again or press ‘▲’ up or ‘▼’ down to select another submenu.
12. Press ‘X’ to return to normal operation.

7.1.8 Review Event Log ‘◆▲ Hi St’

1. Select the review event log ‘◆▲ Hi St’ submenu.
2. The number of logged data events available is indicated by the number of dots (0-7) shown on the left of the display.
3. Press ‘✓’ to view the date of the last recorded event.
4. Press ‘✓’ to display the time of the event.
5. Press ‘✓’ again to display the relevant alarm icon and event code.
6. Repeat to view next logged event details.
7. Press ‘X’ to return to normal operation.

Note

More detailed event log information can be viewed using the web browser feature. Refer to [Section 13](#) for further details

7.1.9 Review LCD Backlight Mode 'LCD'

1. Select the review 'LCD' submenu and press '✓' to accept.
2. The LCD Backlight mode setting is displayed.
3. Press 'X' to return to normal operation.

7.2 Set-up, Calibration, and Test Modes

WARNING

Set-up, calibration and test modes are intended for use by trained personnel or service engineers only. Access to these modes can be pass code protected by following the procedure in Section 7.2.7.

Set-up, calibration and test modes are used to make setting changes, calibrate and test the detector. To select set-up, calibration or test mode press and hold the '▲' up button or '▼' down button for a second to enter the menu. The unit will automatically go to the main normal operation status display from setup/calibration/test menus (but not from inside a setup/calibration/test function) if no button is pressed for 5 minutes or if an alarm level is exceeded.

PASS CODE: If a pass code has been set the display will show 0000 with the first 0 flashing. Use the '▲' up or '▼' down buttons to set the first digit of the pass code. Press '✓' to enter the first digit. The second digit will then flash. Repeat the process until all four pass code digits have been entered. If an incorrect code is entered the display will show

'Err' and return to the normal operation mode. If a pass code is forgotten contact your local Honeywell Analytics service department.

Note

Should the passcode be activated, the unit will continue to detect gas and indicate maintenance and instrument faults.

After successfully entering the pass code (if set) the first menu 'SET' set-up icon will show on the display. The 'CAL' calibration or 'TEST' test menu can also be selected using the '▲' up or '▼' down buttons. Press the '✓' accept button to enter the selected menu or the 'X' cancel button to return to normal operation mode.





Honeywell

Midas® Gas Detector

7.2.1 Set-up Menu 'SET'

The set-up menu allows the settings of the detector to be changed. The set-up menu consists of 6 submenus as shown in the table below.

Table 7-2. Set-up mode submenus.

Set-up submenu	Icon	Changeable settings
Alarms		Gas ID, alarm 1 and alarm 2 configuration, set points, time delay, latching/non latching, energized/de-energized
4-20 mA output	mA	4 mA, gas conc. corresponding to 4 mA; 20 mA, gas conc. corresponding to 20 mA
Faults		Configuration, latching/non latching, energized/de-energized, m12 fault frequency, temperature fault enable/disable
Calibration		Calibration interval (days)
Time/Date	tmE	Date format mm:dd or dd:mm, current year, month, day, hours, minutes
IP address		Auto address selection on/off, IP address, subnet mask values.
Pass code		Set pass code
LCD backlight	LCD	backlight mode (bm:m or bm:c)
Pump frequency	PUmP	use arrows ('▲' or '▼') to adjust frequency



Note

All settings in a submenu are accepted when the '✓' accept button is pressed after the last submenu setting. This saves the changes and is indicated by displaying 'UPdt' on the LCD. If however the 'X' cancel button is pressed at any time before the changes are accepted, this will cause any changes to be cancelled in that particular submenu.

To select the set-up menu from normal operation,

press the '▲' up button for a few seconds. Enter the pass code (if set). Use the '▲' up or '▼' down buttons to select the set-up menu  icon and press the '✓' accept button.

7.2.2 Set Alarms 'ALM'

1. Use the '▲' up or '▼' down buttons to select the set alarms  'ALM' submenu and press '✓' to accept.
2. The flashing gas id code is displayed along with the gas cylinder and alarms icon .
3. Use the '▲' up or '▼' down buttons to change the gas ID number (only applicable on multi gas sensor cartridges- See Appendix B).
4. Press '✓' to accept.
5. The flashing level 1 (L1) alarm type is displayed (U) rising or (d) falling.
6. Use the '▲' up or '▼' down buttons to change the alarm type.
7. The flashing alarm 1 value is displayed along with the icon '▲'.
8. Use the '▲' up or '▼' down buttons to change the value.
9. Press '✓' to accept.
10. The flashing level 2 (L2) alarm type is displayed (U) rising or (d) falling.
11. Use the '▲' up or '▼' down buttons to change the alarm type.
12. Press '✓' to display the flashing alarm 2 value along with the icon '▲'.

Honeywell

Midas® Gas Detector

13. Use the '▲' up or '▼' down buttons to change the A2 value.
14. Press '✓' to display the flashing alarm on time delay (seconds).
15. Use the '▲' up or '▼' down buttons to change the alarm on time delay (seconds).
16. Press '✓' to display the flashing alarm output latching (L) or non latching (nL) setting.
17. Use the '▲' up or '▼' down buttons to change between the settings.
18. Press '✓' to display the flashing alarm relays normally energized (nE) or normally de-energized (nd) setting.
19. Use the '▲' up or '▼' down buttons to change between the settings.
20. Press '✓' to update all the changes (UPdt displayed) and return to step 1.
21. Press '▲' up or '▼' down to select another submenu.
22. Press 'X' to return to set-up, calibration and test menu selection.
23. Press 'X' again to return to normal operation.

Note

When replacing a single gas sensor cartridge with the same type single gas sensor cartridge, no change of gas confirmation is required. When changing a multi gas sensor cartridge with the same type multi gas sensor cartridge, the new sensor cartridge will assume the same previously set gas ID and will not request a change gas confirmation. See Appendix B for cartridge information.

7.2.3 Set 4-20 mA output “mA”

1. Use ‘▲’ up or ‘▼’ down buttons to select the set 4-20mA ‘mA’ submenu and press ‘✓’ to accept.
2. ‘4 mA’ is displayed
3. Use ‘▲’ up or ‘▼’ down buttons to change the gas conc. corresponding to 4 mA.
4. Press ‘✓’ to display 20 mA
5. Use ‘▲’ up or ‘▼’ down buttons to change the gas conc. corresponding to 20 mA.
6. Use ‘✓’ to update all the changes (Updt displayed) and return to step 1.
7. Press ‘▲’ up or ‘▼’ down to select another submenu.
8. Press ‘X’ to return to set up, calibration and test menu selection
9. Press ‘X’ again to return to normal operation.

7.2.4 Set Faults ‘△FLt’

1. Use the ‘▲’ up or ‘▼’ down buttons to select the set faults ‘△FLt’ submenu and press ‘✓’ to accept.
2. The flashing fault relay configuration (1FLt, 2 FLt, CmbF or nEtr) is displayed.
3. Use the ‘▲’ up or ‘▼’ down buttons to change the configuration. (See Table 7-3 for details of fault relay configurations)
4. Press ‘✓’ to display the flashing fault output latching (L) or non latching (nL) setting is displayed.
5. Use the ‘▲’ up or ‘▼’ down buttons to change between the settings.
6. Press ‘✓’ to display the flashing fault output normally energized (nE) or normally de-energized (nd) setting.
7. Use the ‘▲’ up or ‘▼’ down buttons to change between the settings.
8. Press ‘✓’ to set the fault m12 frequency.
9. Use the ‘▲’ up and ‘▼’ down buttons to change between settings:

LCD Display	m12 Frequency
Wm 12	cartridge expiration weekly reminder
0m 12	no reminder
1m12	one-time reminder

10. Press ‘✓’ to display the Temperature fault m15 and F80 enable (Y) or disable (n) setting.
11. Use the ‘▲’ up or ‘▼’ down buttons to change between settings.
12. Press ‘✓’ to update all the changes (UPdt displayed) and return to step 1.
13. Press ‘▲’ up or ‘▼’ down to select another submenu.

14. Press 'X' to return to set-up, calibration and test menu selection.

15. Press 'X' again to return to normal operation.

Table 7-3. Fault relay configuration options.

Fault Relay Configuration	Relay 1	Relay 2	Relay 3
Instrument Fault Only (1FLt)	Alarm 1	Alarm 2	Instrument Fault
Separate Fault Relays (2FLt)	Any Alarm	Maintenance Fault	Instrument Fault
Combined Fault Relay (CmbF)	Alarm 1	Alarm 2	Any Fault
Network Remote Control (nEtr)	Remote control of relays via Modbus/TCP or LonWorks®		

Note

Remote control of the relays can be facilitated using Modbus/TCP or LonWorks® control from a centralized control system. In this mode, the Midas® relays are only controlled via the remote system when set to nEtr.

7.2.5 Set Calibration Interval 'CAL'

1. Select the set calibration interval 'CAL' submenu and press '✓' to accept.
2. The flashing display shows the number of days interval after a calibration that a calibration due maintenance fault will be displayed.
3. Use the '▲' up or '▼' down buttons to change the number of days. (If the calibration interval is set below '001' then 'OFF' will be displayed and no user calibration interval will be activated and no reminders displayed)
4. Press '✓' to update the change (UPdt displayed) and return to step 1.
5. Press '▲' up or '▼' down to select another submenu.
6. Press 'X' to return to set-up, calibration and test menu selection.
7. Press 'X' again to return to normal operation.

7.2.6 Set Date and Time 'timE'

1. Select the set date and time 'timE' submenu and press '✓' to accept.
2. The flashing display will show the current date format mm:dd or dd:mm.
3. Use the '▲' up or '▼' down buttons to change the date format.
4. Press '✓' to display the flashing current year setting.
5. Use the '▲' up or '▼' down buttons to change the year setting (between 2003 and 2030).

6. Press '✓' to display the flashing current month setting.
7. Use the '▲' up or '▼' down buttons to change the month setting (between 1 and 12)
8. Press '✓' to display the flashing current day setting.
9. Use the '▲' up or '▼' down buttons to change the day setting (between 1 and 31)
10. Press '✓' to display the flashing hours of current time.
11. Use the '▲' up or '▼' down buttons to change the hours setting (between 00 and 23).
12. Press '✓' to display the flashing minutes of current time.
13. Use the '▲' up or '▼' down buttons to change the minutes setting (between 00 and 59).
14. Press '✓' to update the changes (UPdt displayed) and return to step 1.
15. Press '▲' up or '▼' down to select another submenu.
16. Press 'X' to return to set-up, calibration and test menu selection.
17. Press 'X' again to return to normal operation.

7.2.7 Set Address 'nEt'

Note

Default IP address is 169.254.60.47; subnet mask 255.255.255.0 (when using the LonWorks Interface Module, the default IP address must be used).

1. Select the set address 'nEt' submenu and press '✓' to accept.
2. Press '▲' up or '▼' down to select full web access (WA Y) or read only (WA n) and press '✓' to accept.
3. A flashing 'n' or 'Y' is displayed depending on if auto address detection is on (AU Y) or off (AU n).
4. If automatic address detection (AU Y) is selected then the detector will automatically appoint a valid IP address when it reboots. The Midas® will display "UPdt" and request a reboot after this setting is accepted.
5. If manual address setting (AU n) is selected press '✓' to display the flashing first part of the IP address. The dot on the upper left indicates that the first part of the IP address is being displayed.
6. Use the '▲' up or '▼' down buttons to change the address setting (between 0 and 255)
7. Press '✓' to display the second part of the address. The two dots on the upper left indicate the 2nd portion of the address.
8. Use the '▲' up or '▼' down buttons to change the address setting (between 0 and 255).
9. Repeat for the third and fourth parts of the IP address.
10. Press '✓' to display the flashing first part of the subnet mask value.

11. Use the '▲' up or '▼' down buttons to change the address setting (between 0 and 255).
12. Press '✓' accept and repeat for the second, third and fourth subnet values. The number of dots in the upper left indicates which part of the subnet address is being viewed.
13. Press '✓' to update the changes (UPdt displayed). The unit will request a reboot to implement the IP configuration.

Note

If the IP address is changed the new settings will not be implemented until the Midas® unit is rebooted.

7.2.8 Set pass code 'PwD'

1. Select the set pass code 'PwD' submenu and press '✓' to accept.
2. Press '▲' up or '▼' down to set the first pass code value. (Note: Holding down the button will increase the increment speed).
3. Press '✓' to enter the first value and move to setting the second value.
4. Press '▲' up or '▼' down to set the second value.
5. Press '✓' to enter and repeat for the third and fourth values in the passcode.
6. To confirm the pass code re enter it again using the same procedure.
7. The new pass code will be saved after the last entry if the two entered passcodes are the same.

Note

Pass codes can be set between 0001 and 9999. Setting the pass code to 0000 will switch off the pass code. If a pass code is forgotten contact your local Honeywell Analytics service department. In the event that a pass code is forgotten by the user, Honeywell Analytics is not responsible for any costs associated with the recovery of the passcode nor for any inconvenience incurred while the user is unable to access protected settings. It is strongly advised that the user record all pass codes with the instrument serial number in a secure and separate location to the Midas® unit. Delays in recovering the lost passcodes may be experienced and are not the responsibility of Honeywell Analytics.

7.2.9 Set LCD Backlight mode

1. Select the set LCD mode 'LCD' submenu and press '✓' to accept.
2. The flashing LCD Backlight mode configuration (bm:m or bm:c) is displayed.
3. Use the '▲' up or '▼' down buttons to change the configuration.
4. Press '✓' to set LCD backlight mode. (UPdt displayed)
5. Press 'X' to return to set-up, calibration and test menu selection.
6. Press 'X' again to return to normal operation.

Note

Midas Generation 1 software versions 1.12 and later and all Midas Geration 2 software versions include automatic pump frequency detection. Manual setting of pump control frequency is uncommon and is needed only if pump frequency differs significantly from the expected range.



7.2.10 Set Pump control frequency

1. Select the set Pump Control Frequency 'PUmP' submenu and press '✓' to accept.
2. The flashing Pump Control Frequency configuration is displayed.
3. Use the '▲' up or '▼' down buttons to change the configuration. (Note: Holding down the button will increase the increment speed.)
4. Press '✓' to set Pump Control Frequency. (UPdt will be displayed)
5. Press 'X' to return to set-up, calibration and test menu selection.
6. Press 'X' again to return to normal operation.

7.3 Calibration Menu ‘CAL’

The calibration menu allows the calibration settings of the detector to be changed. The calibration menu comprises of 4 submenus as shown in the table below.

Table 7-4. Calibration mode submenus.

Calibration submenu	Icon	Calibration setting
Zero		Set detector zero
Span		Set detector span
Flow		Calibrate detector sample flow rate
mA	mA	Calibrate detector analog output

To select the calibration menu from normal operation, press the ‘▲’ up button for a few seconds. Enter the pass code (if set). Use the ‘▲’ up or ‘▼’ down buttons to select the calibration menu ‘CAL’ icon and press the ‘✓’ accept button.

7.3.1 Zero Calibration ‘0CAL’

1. Use the ‘▲’ up or ‘▼’ down buttons to select the zero calibration ‘0CAL’ submenu and press ‘✓’ to accept.
2. The zero calibration icon starts flashing in order to tell the user to prepare to apply zero gas.
3. The inhibit ‘INH’ icon is also displayed indicating that no alarm outputs will be generated during this process.
4. For CO₂ calibrations, apply CO₂-free air for three minutes.
5. Press ‘✓’ to confirm when ready and the icon goes steady.
6. For non-CO₂ calibrations, apply the zero gas (or ambient air).
7. The dots on the left of the display indicate progress to a successful zero.
8. The display will show the zero gas reading and if measured to be stable for an appropriate period of time will display ‘PASS’.
9. If the zero calibration is unsuccessful then the display will show an error code (see table below).
10. Press ‘✓’ to accept calibration result (Updt will be displayed).
11. Use ‘▲’ up or ‘▼’ down to select “InhY” or “Inhn” to set Full Inhibit (refer to table 7-8 for details on inhibit states) or keep the initial inhibit state.
12. Press ‘✓’ to accept inhibit state.
13. Use ‘▲’ up or ‘▼’ down to set the inhibit timeout from 0 minutes to 4 hours. The timeout value will be displayed as hour : minute. The default value is 30 minutes (00:30).
14. Press ‘✓’ to accept the inhibit settings (Updt will

be displayed).

15. The selected outputs will be inhibited until the inhibit timeout has elapsed.
16. Press '▲' up or '▼' down to select another submenu.
17. Press 'X' to return to set-up, calibration and test menu selection.
18. Press 'X' again to return to normal operation.

Note

If the inhibit timeout elapses before the inhibit state is set back to "nonE," the maintenance fault code m17 will be displayed.

7.3.2 Span Calibration 'SPAN'

1. Use the '▲' up or '▼' down buttons to select the span calibration 'SPAN' submenu and press '✓' to accept.
2. The span calibration icon starts flashing in order to tell the user to prepare to apply span gas.
3. The inhibit '🔒' icon is also displayed indicating that no alarm outputs will be generated during this process.
4. Use the '▲' up or '▼' down buttons to select the gas ID code of calibration gas (for multi gas ID sensor cartridges only) and press '✓' to accept. (Refer to Appendix B for details of gas ID codes).
5. Use the '▲' up or '▼' down buttons to select if humidified 'HUm' or dry 'drY' calibration gas is being used.
6. Use the '▲' up or '▼' down buttons to change the value to the concentration of span calibration gas being used.
7. For CO2 calibrations, apply the span gas for three minutes.
8. Press '✓' to confirm when ready and the icon goes steady.
9. For non-CO2 calibrations, apply the span gas.
10. The dots on the left of the display indicate progress to a successful span.
11. The display will show the span gas reading and if measured to be stable for an appropriate period of time will display 'PASS'.
12. If the span calibration is unsuccessful then the display will show an error code (see below).
13. Press '✓' to accept calibration result (Updt will be displayed)

Honeywell

Midas® Gas Detector

14. Use '▲' up or '▼' down to select the purging timeout from 0 min. to 99 min. Default purging time is 3 min.
15. Press '✓' to accept the purging time.
16. Remaining purging time in second will be displayed.
17. Remove the gas and allow the detector to sample clean air for two minutes.
18. Use '▲' up or '▼' down to select the purging timeout from 0 min. to 99 min. Default purging time is 3 min.
19. Press '✓' to accept the purging time.
20. Remaining purging time in second will be displayed.
21. Use '▲' up or '▼' down to select 'InhY' or to 'Inhn' to set Full inhibit(Refer to table 7-8 for details on inhibit states) or keep initial inhibit state.
22. Press '✓' to accept inhibit state.
23. Use '▲' up or '▼' down to set the inhibit timeout from 0 minutes to 4 hours. Timeout value will be displayed as hour : minute. Default value is 30 minutes(00:30).
24. Press '✓' to accept inhibit settings (Updt will be displayed)
25. The selected outputs will be inhibited until the inhibit timeout has elapsed.

Note

If the inhibit timeout elapses before the inhibit state is set back to 'nonE,' maintenance fault code M17 will be displayed.

Note

The change in the gas bottle icon's contents gives an indication of the relative stability of the gas reading. The arrows and bars inside the cylinder indicate whether it is rising or falling as appropriate (see table below).

Table 7-5. Calibration codes.

Code	Code meaning
PASS	Successful Calibration
FL:0H	Zero Calibration Timeout - Over Range
FL:0L	Zero Calibration Timeout - Under Range
FL:0U	Zero Calibration Timeout - Unstable
FL:SH	Span Calibration Timeout - Over Range
FL:SL	Span Calibration Timeout - Under Range
FL:SU	Span Calibration Timeout - Unstable

Table 7-6. Calibration stability icons.

■	Stable
▲	Over-Range
▲ ▲	Unstable-Rising
▲ ▼	Unstable-Flat
▼ ▼	Unstable-Falling
▼	Under-Range

7.3.3 Flow Calibration 'FLoW'

1. Use the '▲' up or '▼' down buttons to select the flow calibration 'FLoW' submenu and press '✓' to accept.
2. The flow icon with the dot at the bottom starts flashing in order to tell the user that the unit is ready to read the zero flow offset.
3. The inhibit '🚫' icon is also displayed indicating that no alarm outputs will be generated during this process.
4. Press '✓' to confirm and the icon goes steady and a count down from 10 is shown as the zero flow offset is read.
5. The display will show the flashing flow icon with the dot approximately 1/2 way up the icon to tell the user to set the set point 1 flow (500 cc/min).
6. Press '▲' up or '▼' down keys to adjust the reading on the external flow meter to the setpoint 1 target value. (NOTE: The reading must be +/- 50 cc/min of target to be accepted).
7. Press '✓' to confirm and the target value flashes.
8. Press '▲' up or '▼' down to enter the actual value read on the external flow meter. (NOTE: Holding down the button will increase the increment speed).
9. Press '✓' to confirm and the icon goes steady and a count down from 10 is shown as the setpoint 1 value is read.
10. The display will show the flashing flow icon with the dot 3/4 ways up to tell the user to set the set point 2 flow (650 cc/min).
11. Press '▲' up or '▼' down keys to adjust the reading on the external flow meter to the set point 2 target value. (NOTE: The reading must be +/- 50 cc/min of target to be accepted).
12. Press '✓' to confirm and the target value flashes.
13. Press '▲' up or '▼' down to enter the actual value read on the external flow meter. (NOTE: Holding down the button will increase the increment speed).
14. Press '✓' to confirm and the icon goes steady and count down from 10 is shown as the setpoint 2 value is read.
15. If successful the display shows UPdt (update) and the flow calibration is complete.
16. Press '▲' up or '▼' down to select another submenu.
17. Press 'X' to return to set-up, calibration and test menu selection.

Honeywell

Midas® Gas Detector

7.3.4 mA Calibration ‘mA 4-20’

This function permits the calibration of the 4-20 mA output using an external source such as an ammeter. The purpose of this calibration is to assure the proper output voltage to activate external alarms/relays.

If the Midas chassis becomes disassociated from its original mounting bracket, this calibration procedure must be followed to assure proper output voltages as the factory calibration is invalidated.

1. Use the ‘▲’ up or ‘▼’ down buttons to select the mA calibration ‘mA 4-20’ submenu and press ‘✓’ to accept.
2. The display shows 4.00 mA indicating that the analog output should be reading 4 mA
3. The inhibit ‘🚫’ icon is also displayed indicating that no alarm outputs will be generated during this process.
4. Use the ‘▲’ up or ‘▼’ down buttons to adjust the analog output to read 4.00 mA.
5. Press ‘✓’ to accept.
6. The display will show 20.00 indicating that the analog output should be outputting 20 mA.
7. Press ‘▲’ up or ‘▼’ down to select another submenu.
8. Press ‘X’ to return to set-up, calibration and test menu selection.
9. Press ‘X’ again to return to normal operation.

7.4 Test Menu ‘🔍tEST’

The test menu is used to test the detector gas reading using bump test gas, and for simulation of alarm and fault display and output operation (relay, analog and digital). The test submenu also includes the detector inhibit facility. The test menu comprises of 3 submenus as shown in the table below.



Caution

When using the Test Mode with the Midas®, be aware that simulations for alarm and fault will trigger any connected devices from the relay, mA, and/or digital outputs (Modbus /TCP, LonWorks®) as if a real alarm or fault is present. If you wish to avoid activating any connected alarms or devices use the Inhibit mode to prevent an unwanted alarm.

Table 7-7. Test mode submenus.

Test Submenu	Display	Icon	Test
Bump	bUmP		Bump test detector with inhibited alarm outputs
4-20	4-20	mA	Stimulate current output
Inhibit	Inh		Put the unit into/out of an inhibit state and set inhibit time out
Alarm/Fault	Slm		Simulate an alarm and fault condition

To select the test menu from normal operation, press the ‘▲’ up button for a few seconds. Enter the pass code (if set). Use the ‘▲’ up or ‘▼’ down buttons to select the test menu ‘🔍’ icon and press the ‘✓’ accept button.

7.4.1 Bump Test ‘bUmP’

1. Use the ‘▲’ up or ‘▼’ down buttons to select the bump test ‘bUmP’ submenu and press ‘✓’ to accept.
2. The inhibit ‘⊘’ icon is also displayed indicating that no alarm outputs will be generated during this process.
3. Apply the bump test gas and the display will show the measured gas concentration.
4. Remove the bump test gas and allow the detector reading to return to zero.
5. Press ‘X’ to exit.
6. Press ‘▲’ up or ‘▼’ down to select another submenu.
7. Press ‘X’ to return to set-up, calibration and test menu selection.
8. Press ‘X’ again to return to normal operation.

Note

In bump test mode, the Modbus/TCP outputs are not inhibited. Only the 4-20mA and alarm outputs are inhibited. The bump gas test is a functional check only. Consult local guidelines for recommended best practices. Bump test concentrations recommended in Section 17 are calculated to generate a minimum first alarm level response.

7.4.2 Alarm/Fault Test ‘SIm’

1. Use the ‘▲’ up or ‘▼’ down buttons to select the alarm/fault test ‘SIm’ submenu and press ‘✓’ to accept.
2. The display shows ‘SIm’ and the A1 ‘▲’ icon.
3. Use the ‘▲’ up or ‘▼’ down buttons to select A1 ‘▲’, A2 ‘▲’ or Fault ‘▲’ for test simulation. A steady ▲ indicates an m9 simulated fault and a flashing ▲ is an F39 simulated fault.
4. Press ‘✓’ to select and ‘SurE’ is displayed to indicate that the next step will activate the selected output (relay, analog and digital)
5. Press ‘✓’ and the display flashes ‘on’ indicating that the selected output is activated
6. Press ‘X’ to return to step 2 and select a different output for test.
7. Press ‘X’ to exit.
8. Press ‘▲’ up or ‘▼’ down to select another submenu.
9. Press ‘X’ to return to set-up, calibration and test menu selection.
10. Press ‘X’ again to return to normal operation.

Note:

If latching faults or latching alarms are set up and either of those are simulated, then the user will have to reset them with the ‘X’ button in normal operation mode.

Honeywell

Midas® Gas Detector

7.4.3 Inhibit State ‘ InH’

1. Use the ‘▲’ up or ‘▼’ down buttons to select the inhibit ‘ InH’ submenu and press ‘✓’ to accept.
2. The display flashes ‘nonE’ indicating there is no inhibit currently set.
3. Use the ‘▲’ up or ‘▼’ down buttons to select alarm, alarm and fault or all (ALm, AL-Ft or ALL) output inhibit states. See Table 7-8 for details of inhibit states.
4. Press ‘✓’ to accept the selected inhibit state.
5. Press ‘▲’ up or ‘▼’ down to set the inhibit timeout (between 0 minutes and 4 hrs - default 30 minutes).
6. Press ‘✓’ to accept (UPdt displayed).
7. The selected outputs will be inhibited until the inhibit timeout has elapsed.

Note

If the inhibit timeout elapses before the inhibit state is set back to ‘nonE’ the maintenance fault code M17 will be displayed.

8. To take the unit out of inhibit, select the inhibit ‘ InH’ submenu and press ‘✓’ to accept.
9. Use the ‘▲’ up or ‘▼’ down buttons to select ‘nonE’
10. Press ‘✓’ to return to the submenu selection.
11. Press ‘▲’ up or ‘▼’ down to select another submenu.
12. Press ‘X’ to return to set-up, calibration and test menu selection.
13. Press ‘X’ again to return to normal operation.

Table 7-8. Inhibit states.

Inhibit State	Display	Function
None	nonE	No functions are inhibited.
Alarms Inhibited	ALm	Alarm events will be detected, but alarm outputs (relays, 4-20 mA current loop and Ethernet) will be disabled.
Alarms and Faults Inhibited	AL-Ft	Alarm and fault events will be detected, but alarm and fault outputs (relays, 4-20 mA current loop and Ethernet) will be disabled.
Full Inhibit	ALL	All monitoring functions inhibited. No monitoring is performed and no alarms or faults (except for Inhibit Timeout) will be reported.

7.4.4 Stimulate 4-20mA '4-20 mA'

1. Use the '▲' up or '▼' down buttons to select the '4-20' submenu and press '✓' to accept.
2. The display shows 'S 04' indicating a 4 mA output is being stimulated.
3. Use the 's' up or '▼' down buttons to increase or decrease current as desired in the range of 1 to 21 mA. Displayed as "S xx" = xx indicating mA current being output.
4. Press 'X' to return to the '4-20' submenu selection.
5. Press 'X' to return to set-up, calibration and test menu selection.
6. Press 'X' again to return to normal operation.



Caution

Proceeding with 20 mA stimulation may cause unexpected alarm activation.

Only authorized operators should perform this task!

This mode cancels itself in 5 minutes.

8 Maintenance

Honeywell

Midas® Gas Detector

8 Maintenance

Midas® is a fully serviceable product designed with modular components that can be readily replaced by trained service personnel so as to minimize the time that the gas detector is not available.

External in-line air filters should be replaced every three months or more frequently if the system is sampling in environments that have high levels of particulate matter or very acidic / wet atmospheres. Similarly, the internal particulate filter should be replaced once a year or more frequently if the sample lines are prone to heavy contamination.

Every sensor cartridge is shipped with a 12 month warranty and an extended 2 year warranty sensor cartridge is also available for purchase. All sensor cartridges are factory calibrated to traceable national standards before shipment to the end user.

Note that testing or calibrating with the wrong (incorrect, out of date, non-traceable) calibration gases, calibration equipment, methods or operating conditions can actually damage the sensor cartridge's lifetime and alter the calibration adversely. Only qualified calibration technicians should attempt to calibrate the Midas® gas detector.

Note

For details regarding sensor cartridge calibration and bump testing method refer to [Section 17](#).

The internal pump module is designed to operate for a minimum of 24 months and it is recommended that this pump module (part number MIDAS-A-007) be replaced every 2 years.

Recommended Maintenance Schedule	
Component	Frequency
Pump	2 years/as needed
Pyrolyzer (all models)	1 year
Internal Filter	2 years/as needed
External Sample Line Filter	780248 3-6 months
	1991-0147 3-6 months
	1830-0055 3-6 months
	1830-0027 1 month
Leak Check	Leak Check every 6 months or after pump, pyrolyzer or internal filter replacement.
Bump Test	6 months
Flow Calibration	Flow Calibrate after pump, pyrolyzer or internal filter replacement.

See [Appendix B](#) for the correct filter requirement for your application.

Note

The CO2 cartridge MIDAS-S/E-CO2 bias battery will last only about 9 months. After replacement, allow at least a day for the cartridge to reach equilibrium.

Honeywell

Midas® Gas Detector

8.1 Sensor Cartridge Replacement

Honeywell Analytics recommends that the sensor cartridge be replaced without power to the Midas® unit. If fitting a sensor cartridge to a unit that is powered, please refer to [Section 7.4.3](#) to inhibit the detector's outputs.

8.1.1 Sensor Cartridge Fitting/Replacement

1. Unscrew the thumbscrew located on the front panel and remove the cover by pulling it forwards off the main chassis (see Diagram 27).
2. Ensure the power switch on the terminal module is in the off position.
3. Remove the old sensor cartridge from the unit (if fitted) by unclipping the two sensor cartridge locking tabs located either side of the sensor cartridge and using them to firmly pull the sensor cartridge out (see diagram 23).
4. Fit the new sensor cartridge by aligning the pins at the top of the sensor cartridge with the socket in the sensor cartridge chamber.
5. Carefully push the sensor cartridge into the sensor cartridge chamber until fully home and lock in place using the tabs either side of the sensor cartridge (see diagram 24).
6. Switch the power switch on the terminal module to the 'on' position.
7. Refit the detector's cover by aligning the slots either side of the locating tabs on the mounting bracket assembly and pushing the cover horizontally until home. Tighten the thumbscrew located on the front panel (see

diagram 25).

8. Confirm that the LCD messages "LOAD" and "WARM" are replaced by a zero concentration display. Confirm that the yellow fault LED is off.

Note

If replacing a sensor cartridge with a different gas type sensor cartridge the display will scroll the message 'ChAnGE gAS?' If you are changing the sensor cartridge gas type press '3' to accept. If not, fit the correct sensor cartridge. The pass code (if set) must be entered to change sensor cartridge gas type. To set the correct gas for a multi gas type sensor cartridge refer to [Section 7.2.2](#).

Diagram 8-1. Removing detector cover

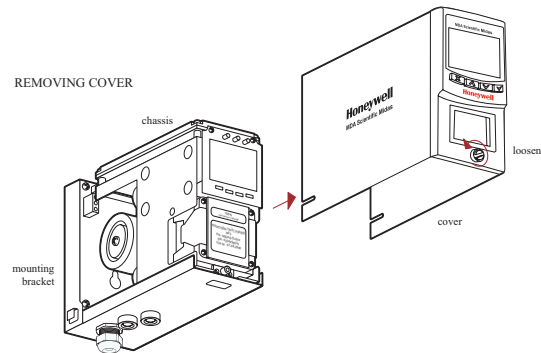
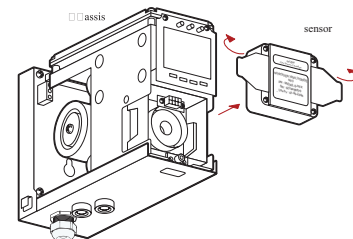

Diagram 8-2. Removing sensor cartridge



Honeywell

Midas® Gas Detector

Diagram 8-3. Fitting/replacing sensor cartridge

HOW CARTRIDGE IS FITTED

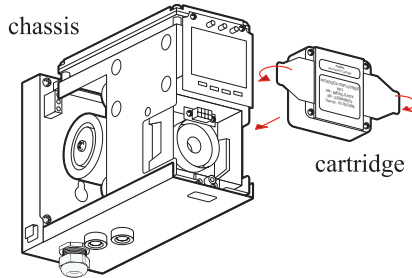
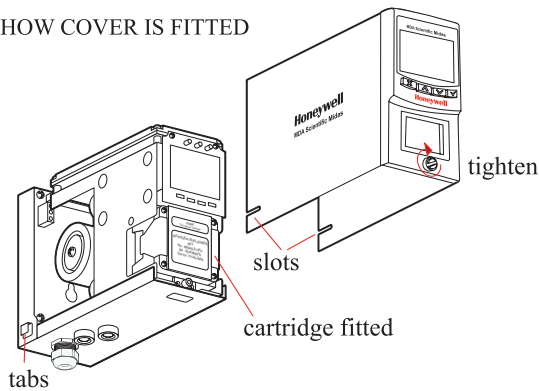

Diagram 8-4. Refitting detector cover

HOW COVER IS FITTED



Caution

When refitting the cover to the Midas® unit, use caution to prevent damage to the RFI shielding tabs attached to the chassis.

8.2 Pump Replacement

The pump module has been designed to allow easy replacement. New pump modules, (MIDAS-A-007), are supplied with new springs, bracket and tubing pre-assembled for quick release / replacement.

Diagram 8-5. Location of pump module.

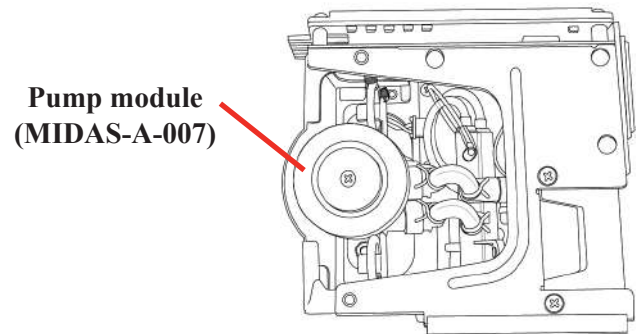

The following procedure should be followed carefully and only performed by suitably trained personnel.

1. Isolate the power to the detector.
2. Unscrew the thumbscrew located on the front panel.
3. Remove the cover by pulling it forward off the main chassis.
4. Unscrew the two retaining screws located at the bottom front of the chassis.
5. Pull the main chassis forward to disconnect it from the mounting bracket assembly.

6. Remove the 4 pump module screws.

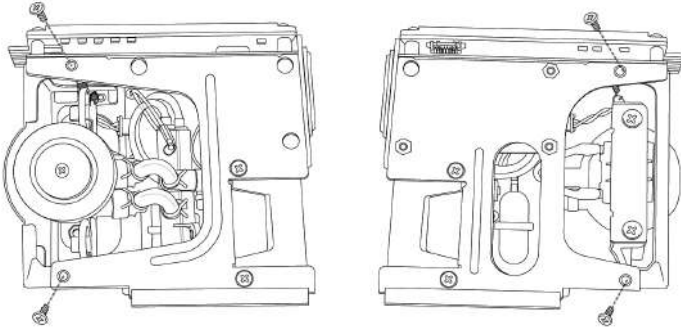

7. Remove the two fixing clips and disconnect the tubes at the manifold.

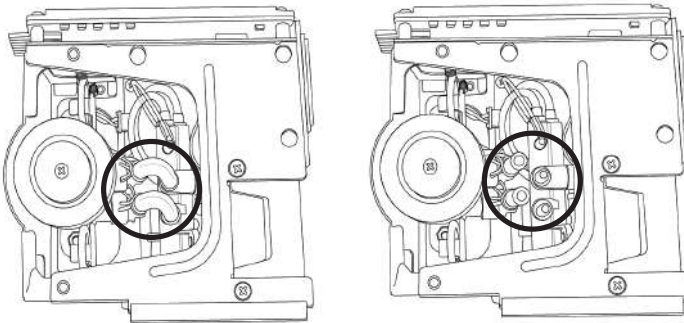

8. Slide the pump module out and disconnect the connector from the pcb.

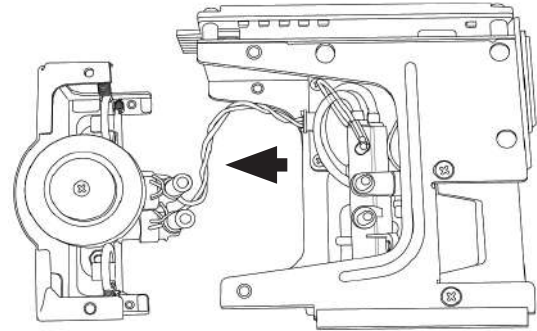

9. Fit the new pump module following the steps above in reverse order. Orient the metal retaining clamps away from the pump wiring to prevent damage. Route pump wiring away from the chassis and manifold to prevent damage.

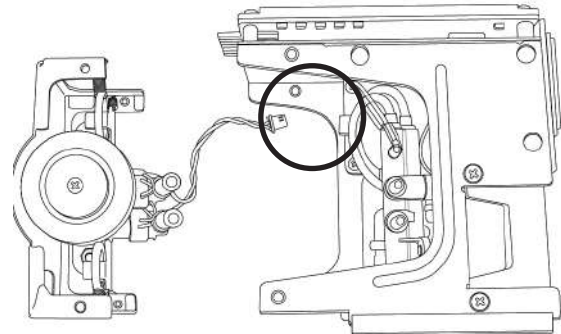

Honeywell

Midas® Gas Detector

8.3 Reassembling the Detector

1. Align the PCB at the top rear of the main chassis with the connector located at the top of the mounting bracket assembly.
2. At the same time align the two tubes at the bottom rear of the main chassis with the two tubes located on the bottom of the mounting bracket assembly.
3. Slide the chassis backwards on the mounting bracket assembly so that the PCB, connector and tubes engage simultaneously.
4. Ensure the PCB, connector and tubes are fully engaged by firmly pushing the main chassis horizontally backwards on the mounting bracket assembly.
(WARNING: DO NOT PUSH ON THE LCD AS THIS MAY CAUSE DAMAGE).
5. Align the two attaching screws located at the bottom of the chassis with the screw threads on the mounting bracket assembly.
6. Tighten the screws to secure the chassis to the mounting bracket assembly.
7. Switch the power switch on the terminal module to the 'on' position.
8. Refit the detector's cover by aligning the slots either side with the locating tabs on the mounting bracket assembly.
9. Push the cover horizontally until home.
10. Tighten the thumbscrew located on the front panel.

Note

Honeywell Analytics recommends conducting a "Flow Calibration" (See [Section 7.3](#) for instructions)

8.4 Filter Replacement

The internal filter (MIDAS-A-009) has been designed for easy replacement.

The following procedure should be followed carefully and only performed by suitably trained personnel.

1. Isolate the power to the detector.
2. Unscrew the thumbscrew located on the front panel.
3. Remove the cover by pulling it forwards off the main chassis.
4. Unscrew the two retaining screws located at the bottom front of the chassis.
5. Pull the main chassis forward to disconnect it from the mounting bracket assembly.
6. Locate the filter access slot in the side of the main chassis.

Diagram 8-6. Filter location.

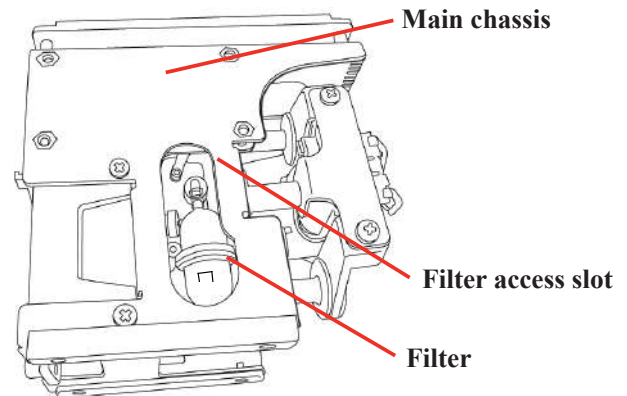

7. Carefully disconnect both sides of the filter from the pump manifold.
8. Remove the old filter and replace with a new

Honeywell

Midas® Gas Detector

filter ensuring that the filter connectors are fully engaged in the manifold ports and that the filter is the correct orientation (arrow pointing downwards). Orient the metal retaining clamps away from the pump wiring to prevent damage.

9. Route pump wiring away from the chassis and manifold to prevent damage.

Diagram 8-7. Filter orientation.

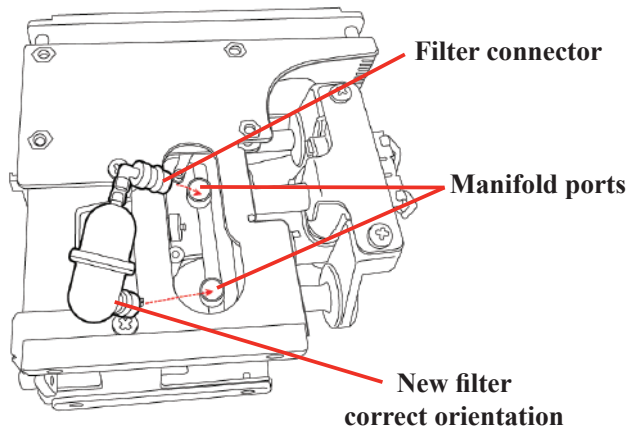

8.5 System Leak Check Procedure



When performing a leak check, the Midas® must be placed in inhibit mode to prevent false concentrations or faults to be activated when plugging the Sample and/or Exhaust Lines.

Example: O₂ (oxygen) – plugging of the ports causes the O₂ levels within the Midas® flow path to be depleted as the sample becomes stagnant. The result is the concentration levels begin to fall and trigger the alarms for the O₂ depletion.

1. Place the Midas® into Inhibit (see [Section 7.4.3](#))
2. Plug the Inlet Sample line (see Diagram 8-8)
3. The flow meter indicators will begin to drop and ultimately disappear (within seconds) (see [Diagram 2-3](#))
4. Continue to keep the port plugged until the Midas® reports an “F81” (Flow Fail) – approximate time to fault is 1 minute
5. Remove the plug
6. Allow 15 seconds or so to allow the Midas® flow to stabilize then clear the fault by pressing and holding ‘X’
7. Plug the Outlet Exhaust line
8. The flow meter indicators will begin to drop and ultimately disappear (within seconds)
9. Continue to keep the port plugged until

Honeywell

Midas® Gas Detector

the Midas® reports an “F81” (Flow Fail) – approximate time to fault is 1 minute

10. Remove the plug
11. Allow 15 seconds or so to allow the Midas® flow and concentrations to stabilize then clear the fault by pressing and holding ‘X’
12. Return the unit to normal operation

Diagram 8-8. Port Location.

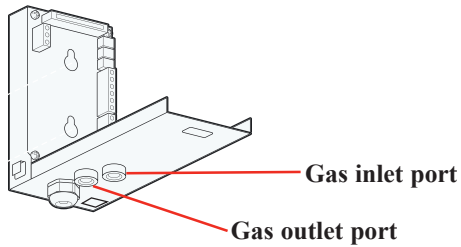

Honeywell

Midas[®] Gas Detector

9 Pyrolyzer Module Options

9 Pyrolyzer Module Options

Two Midas Pyrolyzer modules are available to detect specific gases (consult the Midas data sheets for an updated list of detectable species). The pyrolyzer module option is installed under the Midas gas detector. An air sample is drawn through the pyrolyzer and the target fluorinated compounds are converted into hydrogen fluoride (HF) gas by means of pyrolysis at a high temperature which is optimized for each gas family. The residual HF is then measured by the appropriate sensor cartridge and the concentration is calculated from this result. This concentration is then displayed in actual ppm on the Midas' LCD display.

The standard Midas pyrolyzer unit (P/N MIDAS-T-NP1) detects nitrogen trifluoride (NF_3) and Perfluoro compounds (CH_3F , C_4F_6 , C_5F_8 , CH_2F_2). The pyrolyzer unit for NF_3 , CH_3F and CH_2F_2 can utilize a Freon end-of-line filter (P/N 1830-0027). The filter is filled with charcoal to remove Freon

and other similar compounds from the sample gas before it is "cracked" in the pyrolyzer.

Diagram 9-1 illustrates the various pyrolyzer configurations. This table shows that gases which can be detected by the Midas Pyrolyzer module.

Detectable Gases		
Cartridge Part No.	Gas	Gas ID
MIDAS-E-XHF, MIDAS-S-XHF	NF_3	01
	CH_3F	02
MIDAS-E-XCF, MIDAS-S-XCF	C_4F_6	01
	C_5F_8	02
	CH_2F_2	03

Note that the pyrolyzer module is ideally suited for leak detection rather than analytical detection of very low trace amounts of PFC compounds.

Diagram 9-1. Midas gas detector with pyrolyzer modules (left to right: MIDAS-T-0P3, MIDAS-T-00P, MIDAS-T-HTP, and MIDAS-T-NP1).

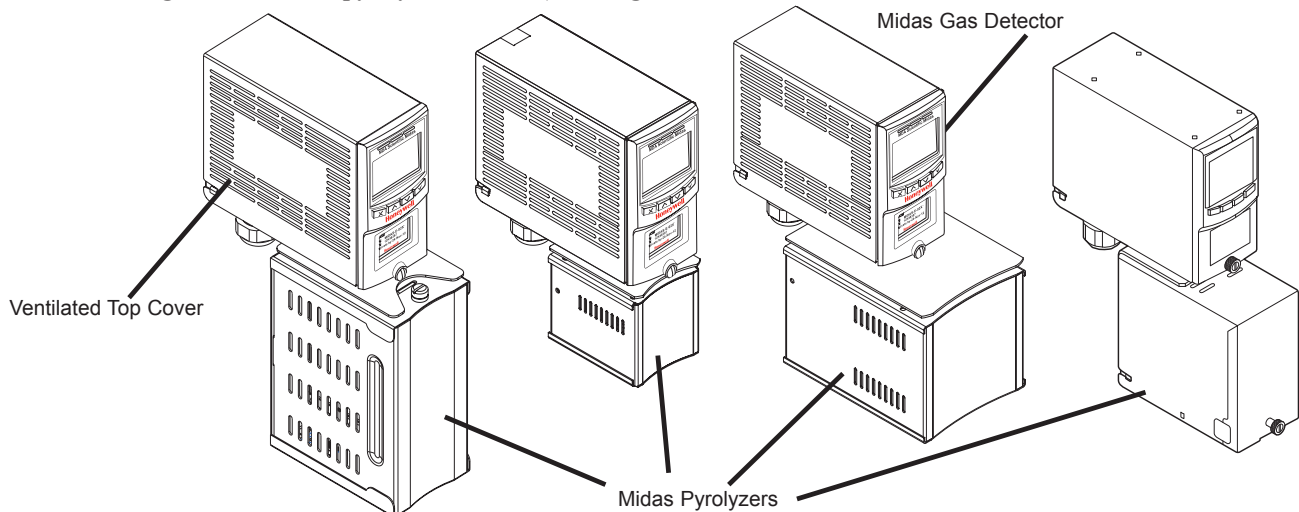

Honeywell

Midas® Gas Detector

To maintain sensor accuracy when using the pyrolyzer, perform a gas calibration every six months. Do not allow the ambient temperature at the point of installation to exceed 40°C (104°F). Operation above this temperature may require more frequent bump testing or calibration to confirm working specification. Because of the higher operating temperatures when using the pyrolyzer module, Honeywell Analytics strongly recommends that the ventilated Midas Top Cover (part number MIDAS-A-039) be used in all pyrolyzer applications.

NOTE: The Pyrolyzer module is serviceable only by trained personnel or by Honeywell Analytics' Service Center. Inappropriate handling can cause injury and device damage.

Note: Le module pyrolyzer pouvant-êre réparé. Par contre la réparation doit-êre effectuée par un personnel qualifié ou à un centre de service autorisé d'Honeywell Analytics. Une manutention inadéquate pourrait causé des blessures ainsi que des dommages à l'appareil.

Diagram 9-2 shows the main components of the pyrolyzer.

Diagram 9-2. Pyrolyzer components.

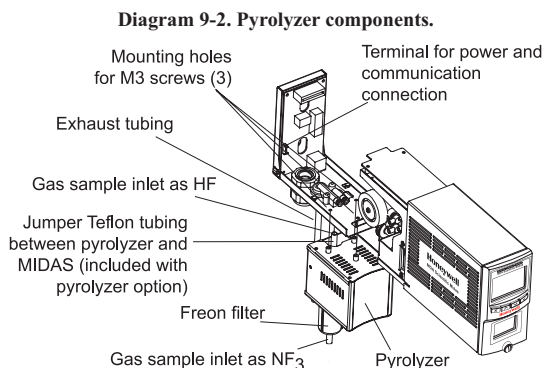
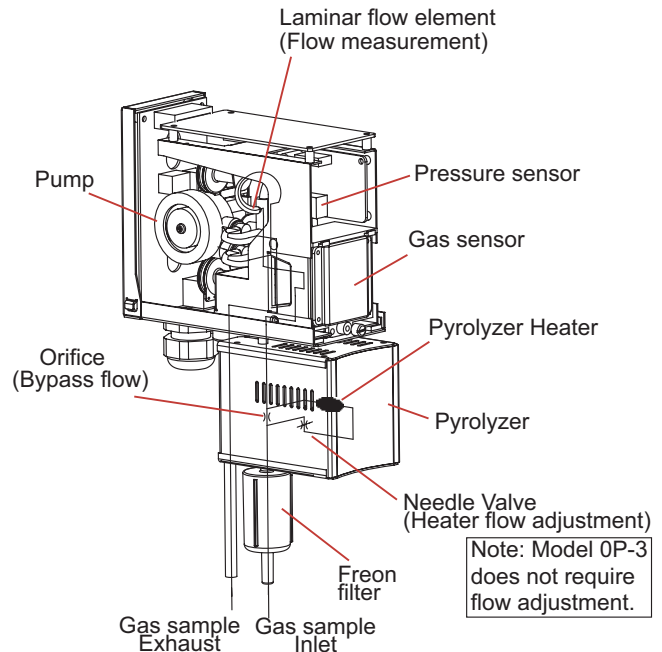

Diagram 9-3 shows in a simple form how a gas sample is drawn through the pyrolyzer module by the pump (located at the end of the gas path). It is first routed to the pyrolyzer via the Freon filter before being sent to the gas sensor cartridge, where the gas measurement is taken. The sample continues via the flow meter through the dust filter and is finally exhausted from the instrument. Adjustment of the gas flow through the instrument is done automatically. It is recommended to perform a leak check (see [Section 8.5](#)) before performing a flow calibration. To perform a flow calibration refer to [Section 7.3.3](#).

Diagram 9-3. Pyrolyzer configuration gas flow.



Honeywell

Midas® Gas Detector

9.1 Fitting the Pyrolyzer Module

1. Disconnect power to the detector.
2. Unscrew the thumbscrew on the front panel.
3. Remove the cover by pulling it forward off the chassis, as illustrated in Diagram 9-4.

Diagram 9-4. Removing the Midas cover.

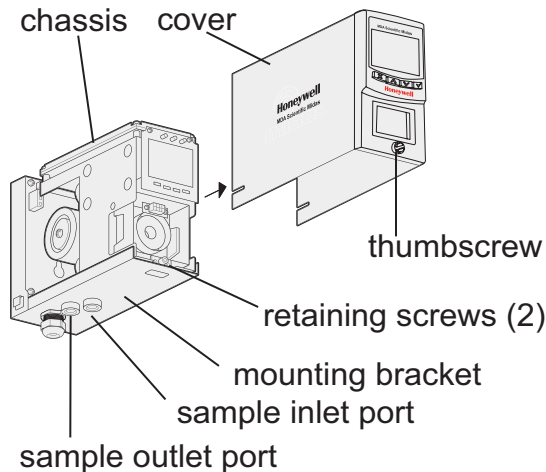

4. Unscrew the two retaining screws located at the bottom front of the chassis.
5. Pull the chassis forward to disconnect it from the mounting bracket assembly (see Diagram 9-5).

Diagram 9-5. Removing the chassis.

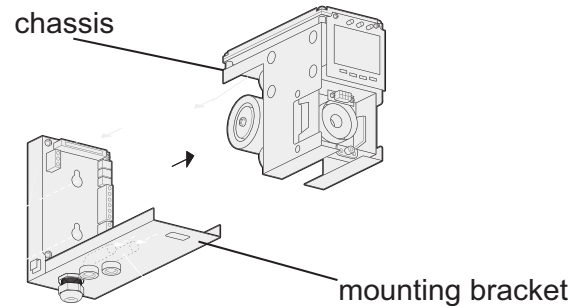

6. Thread the connector and wire harness from the pyrolyzer through the rectangular access in the bottom of the mounting bracket.
7. Secure the wires with a retention clip (if available).
8. Plug the connector into the socket (con5) at the bottom left of the terminal board.
9. Align the fitting at the top rear of the pyrolyzer with the sample and inlet ports at the bottom of the mounting bracket.

Honeywell

Midas® Gas Detector

10. Connect the pyrolyzer to the detector with the three provided mounting screws (see Diagram 9-6).

Diagram 9-6. Attaching the pyrolyzer.

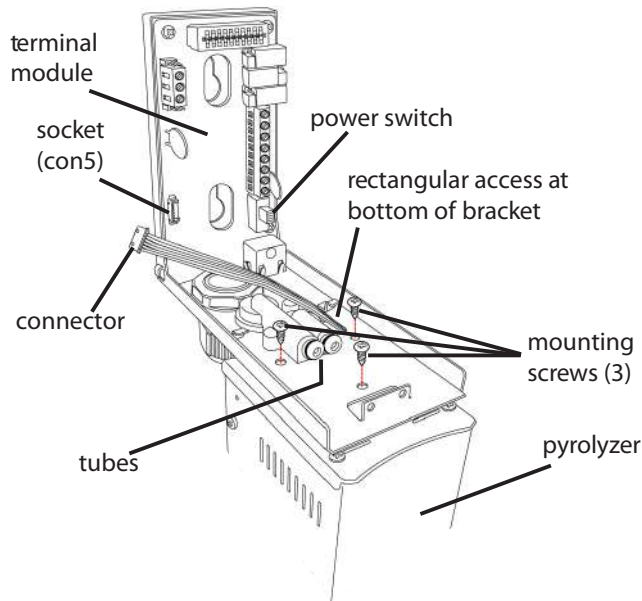

⚠ WARNING To maintain sensor accuracy when using the pyrolyzer, perform a gas calibration every six months. Do not allow the ambient temperature at the point of installation to exceed 40°C (104°F). Operation above this temperature may require more frequent bump testing or calibration to confirm working specification. Because of the higher operating temperatures when using the pyrolyzer module, Honeywell Analytics strongly recommends that the ventilated Midas Top Cover (shown in Diagram 9-1) be used in all pyrolyzer applications.

Note:

Consult the label on the side of the Pyrolyzer module, as shown in Diagram 9-7, for the firmware version level required in the Midas detector for proper operation.

Diagram 9-7. Pyrolyzer label.

P/N: MIDAS-T-NP1
05/16 REV 1 S/N:00001

For non-flammable gases only
www.honeywellanalytics.com

This pyrolyzer is to be used only with Midas extractive units equipped with version 1.10 or later application software.

9.2 Reassembling the Detector

1. Align:
 - a. the PCB at the top rear of the chassis with the PCB connector at the top of the mounting bracket and
 - b. the two tubes at the bottom rear of the chassis with the two tubes on the bottom of the mounting bracket.
2. Slide the chassis backward on the mounting bracket assembly so that the PCB, connector, and tubes engage fully. Push the chassis backward on the mounting bracket.
CAUTION: The LCD is fragile. Do not apply pressure to its surface.
3. Tighten the retaining screws to secure the chassis to the mounting bracket.
4. Insert the MIDAS-S-XHF sensor cartridge into the sensor cartridge chamber (see Diagram 9-8) and refer to the Sensor Cartridge Installation Quick Start Guide (MIDAS-A-021).

Diagram 9-8. Reassembling the detector.

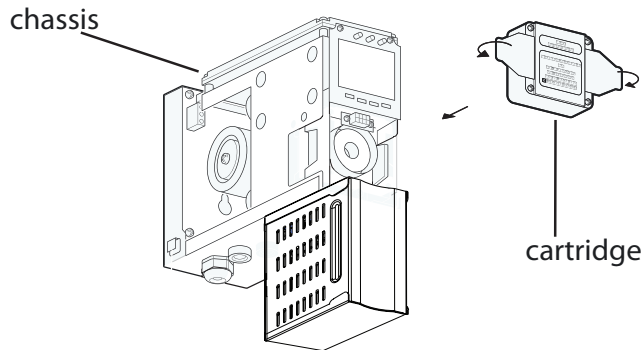

5. Set the power switch to the “on” position.
6. Refit the ventilated top by aligning the slots on either side with the locating tabs on the mounting bracket assembly, shown in Diagram 9-9. Push the cover horizontally until seated.

Diagram 9-9. Refitting the top cover.

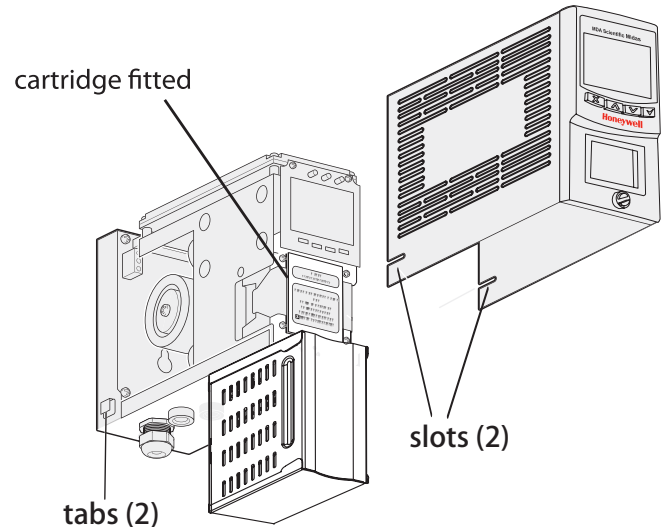

9.3 Configuring the Detector

1. After completion of the startup sequence, press the “▲” button for a few seconds to select the setup menu.
2. Enter the passcode (if necessary).
3. Use the “▲” or “▼” buttons to select the setup menu “☰” icon. Press the “✓” to accept.
4. Use the “▲” or “▼” buttons to select the set alarms “⚠️ ALm” submenu. Press “✓” to accept.
5. The flashing gas ID code and the gas cylinder and alarms icon “⚠️” will appear.
6. Use the “▲” or “▼” buttons to change the gas ID number to that of the target gas. Press “✓” to accept.
7. Continue to accept or change the rest of the alarm settings. For further details on these settings, refer to the Midas Operating Instructions (part number MIDAS-A-001).
8. Press “✓” to update all changes (“UPdt” will be displayed).
9. Press “X” twice to return to normal operation.

After applying power, verify that the sensor cartridge ID and gas ID are appropriate for the target gas. See [Appendix B](#) for gas ID codes. Refer to [Section 7.2.2](#) for the procedure for setting the gas ID code.

The Midas gas detector automatically detects the pyrolyzer module and provides the necessary power and signaling for the device.

Honeywell

Midas[®] Gas Detector

10 Optional LonWorks[®] Interface Installation

10 Midas LonWorks® Interface Module

10.1 LonWorks® Installation

Midas® can be directly integrated within a LonWorks® network using an optional interface module (MIDAS-T-LON). This gateway provides both power and communications to the Midas® transmitter and creates a LonWorks® node on the network. All gas readings, faults and other sensor data are transmitted via the LonWorks® protocol. Any Midas® transmitter can be easily configured to connect with the LonWorks® interface module.

The Midas® LonWorks® interface module is installed behind the standard Midas® gas detector as shown in Diagram 10-1. Power and data connections are supplied directly to the LonWorks® interface module. All power to the Midas® unit is provided via the LonWorks® interface.

Diagram 10-1. Midas® LonWorks® module.

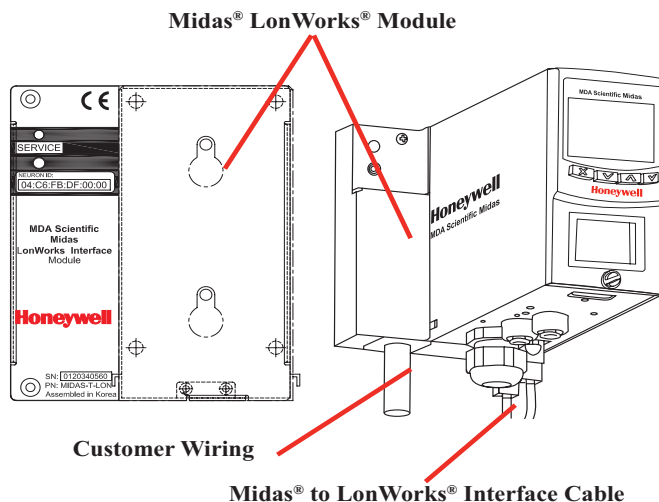

10.1.1 Fitting the LonWorks® Module

1. Unscrew LonWorks® interface top plate.
 2. Mount the interface and tighten screws. See mounting template on reverse side.
 3. Connect 24V DC power and LonWorks® wires to the pluggable connectors. Clamp the cables in the supplied gland as shown in Diagram 10-2. A spare gland is included.
 4. Reinstall top plate on the interface.
 5. Loosen thumbscrew on front of Midas®.
 6. Remove unit cover.
 7. Loosen two screws on bottom front of chassis.
 8. Separate main chassis from mounting bracket assembly.
 9. Mount the Midas® mounting bracket assembly onto the LonWorks® interface.
 10. Tighten screws.
 11. Align the PCB at the top rear of the main chassis with the connector located at the top of the mounting bracket assembly.
 12. Slide the main chassis backwards on the mounting bracket assembly so that the PCB and connector and tubes engage simultaneously.
- WARNING: DO NOT PUSH ON THE LCD AS THIS MAY CAUSE DAMAGE**
13. Tighten the screws to secure the main chassis to the mounting bracket assembly.
 14. Reinstall cover

Diagram 10-2. LonWorks Cable Gland.

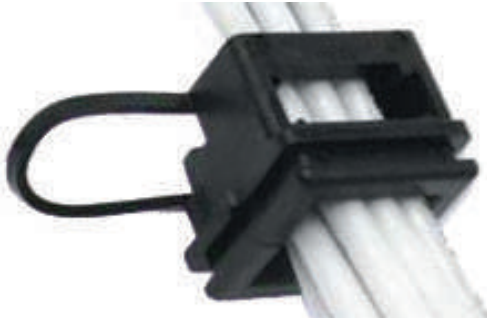

10.1.2 Wiring the Midas® for LonWorks®

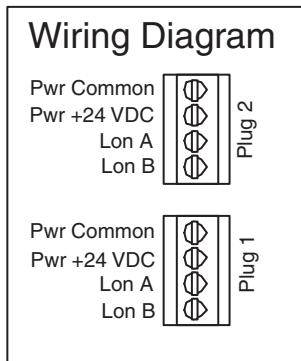

Wiring Notes:

1. Maximum wire size is 16 AWG.
2. Input voltage range is 20.4 to 26.4 VDC. Midas pyrolyzers and transmitters with LonWorks modules have a restricted minimum voltage requirement of 21.6 VDC.
3. It is mechanically possible to misalign Plug1 and Plug2. Care must be taken when inserting plug to assure correct alignment.
4. Plug1 and Plug2 are internally connected in

parallel to facilitate wiring in bus topology.

5. LonWorks® FT-10 wiring is polarity sensitive. Lon A and Lon B may be swapped.

10.1.3 Configuring the Midas® for LonWorks®

1. Turn on 24 VDC power.
2. Confirm that the Midas® initiates the power up sequence.
3. Reset Fault F49 if present.
4. Set alarm levels and other parameters as desired.
5. Confirm that the Midas® IP parameters are at default values. If changed, the DHCP client must be set to 'n'. The IP address must be restored to 169.254.60.47 and the subnet mask must be restored to 255.255.255.0

10.2 LonWorks® Software

10.2.1 LonWorks® Overview

LonWorks® is a communications protocol developed by Echelon Corporation which facilitates peer-to-peer communications in a control network. The Midas® gas detector is available with an optional LonWorks® interface.

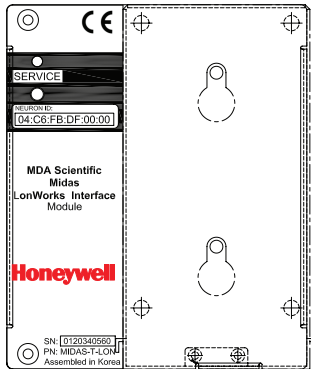

The Midas® uses the Free Topology (FT) physical layer which communicates at 78 Kbaud. Each FT segment can contain up to 64 nodes and up to 2.7 Km of cable. Routers permit expansion of the network to multiple segments.

The Midas® LonWorks® interface contains 2 functional blocks, 19 network variables and 2 network configuration inputs. It is designed for compliance with LonMark guidelines version 3.2. However, it is not LonMark certified. The LonMark representation of the interface is shown in Diagram 10-3.

Information on LonWorks® can be found at www.echelon.com. Information on LonMark can be found at www.lonmark.org. Many commercial LonWorks-compatible products can be found at www.engenuity.com.

Diagram 10-3. LonMark Diagram

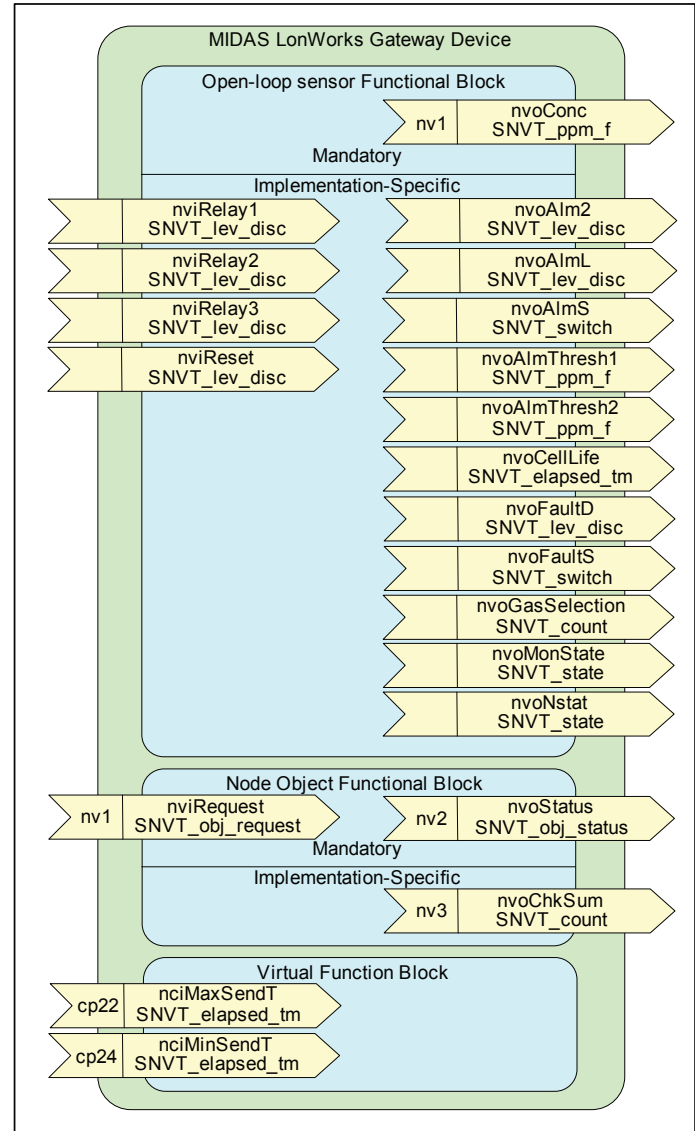

Honeywell

Midas® Gas Detector

10.2.2 Network Variable Behaviors

The behaviors of the network variables are as detailed below:

nvoConc

This reports the concentration of the target toxic or flammable gas in the SNVT_ppm_f data type. The concentration will be scaled in ppm when a toxic gas cartridge is installed. For example a 100 ppb B2H6 concentration will be reported as 0.1. However, when an O2 cartridge is installed, this will be scaled in volume percent. For example, normal air will be reported as 20.9, not 209000.0. Furthermore, concentration will be reported as a percentage of the lower explosive limit (LEL) for flammable gas cartridges. This means that CH4 at a concentration of 50% LEL will be reported as 50.0, not as 25000.0 ppm.

Alarm Outputs

The alarm status of the Midas® is reported in three network variable outputs (NVOs) for maximum compatibility. The values of nvoAlmL, nvoAlm2, and nvoAlmS under various conditions are listed in Table 1. The variable nvoAlm2 is provided to facilitate discrimination between alarm1 and alarm2 by 3rd party actuators which treat SNVT_lev_disc as a Boolean data type. The variable nvoAlmS is provided to increase compatibility with Echelon LonPoint modules.

Note that the values stored in nvoAlmL are slightly different than that of other Honeywell Analytics / MDA Scientific gas detectors. For example, a Vertex will indicate a level 1 alarm by ST_MED. This is because ST_LOW is reserved for small non-zero concentrations below the alarm threshold. Additionally, the System 16, LIFELINE, LIFELINE II

and CM4 indicate a level 2 alarm as ST_MED.

Table 10-1. Alarm Outputs

Alarm Status	nvoAlmL (SNVT_lev_disc)	nvoAlm2 (SNVT_lev_disc)	nvoAlmS (SNVT_switch)
None	ST_OFF	ST_OFF	{0.0, 0}
Level1	ST_LOW	ST_OFF	{0.5, 1}
Level2 without Level 1 (only possible with depletion alarms)	ST_MED	ST_MED	{1.0, 1}
Level 1 and 2 (usual case)	ST_HIGH	ST_MED	{1.5, 1}

nvoFaultD

This has the value ST_MED if an instrument fault exists and the value ST_LOW if a maintenance fault exists. If both faults exist, this takes ST_HIGH. It has the value ST_OFF if no fault exists.

A maintenance fault indicates the Midas® requires attention but is continuing to monitor. An instrument fault indicates a loss of monitoring.

nvoFaultS

This network variable output facilitates identifying the cause of the fault over the network. The .value byte of SNVT_switch will be the fault number. These are listed in Section 6 of the Midas® Quick Start Guide. Additionally, a communication failure will be reported as fault number 100. The .state byte of SNVT_switch has the value 1 if any fault exists. Otherwise it takes the value 0.

Note that the LonMark standard calls for the .value field to be divided by two for display. Thus the raw

Honeywell

Midas® Gas Detector

value is twice the fault number. For example when a flow failure (Fault F81) exists, the raw value of nvoFaultS will be {0xA2, 0x01}. This is displayed by LonMark-compatible tools as {81.0, 1}.

Alarm Thresholds

The variables nvoAlmThres1 and nvoAlmThres2 reports the configuration of the alarm setpoints. The scaling and format of the data is identical to that used with nvoConc. These are read-only data – it is not possible to change the alarm settings over LonWorks®.

nvoGasSelection

This NVO facilitates determining over the network what cartridge is installed and which calibration is selected. The most-significant byte of this is equal to the sensor cartridge ID number. The least-significant byte of this is equal to the gas ID number. Values for both are listed in [Appendix B](#).

nvoCellLife

This reports the time remaining until the F43 (“Cartridge Expired”) is issued. Fault m12 (“Cartridge Expires Soon”) will generally be issued 30 days before F43. However, this variable provides no advance warning of fault m11 (“User Cal Expired”).

nvoMonState

The bits in this variable are shown graphically in Table 10-2. The least-significant 4 bits form a monitoring mode integer (MMI). Bit 7-2 form a heartbeat counter which increments every 2 seconds. The heartbeat counter is provided to facilitate confirmation of communication. This variable propagates every nciMinSendT since it is always changing.

Table 10-2. nvoMonState Bit Assignment

bit 0 MSB	bit 1	bit 2	bit 3	bit 4	bit 5	bit 6	bit 7	bit 8	bit 9	bit 10	bit 11	bit 12	bit 13	bit 14	bit 15 LSB
Always Zero		Heartbeat Counter				Always Zero				Monitoring Mode Integer					

The description of the Monitoring Mode Integers are listed in Table 10-3 below.

Table 10-3. Monitor Mode Integer Description

Monitoring Mode Integer	Description
0	Warmup
1	Monitoring without inhibit
2	Alarms inhibited
3	Alarms, and faults inhibited
4	Alarms, faults and concentrations inhibited
5	Simulation
6	Bump test mode
7	4-20 mA calibration mode
8	Other calibration mode
9 to 14	for future expansion
15	Communications failure.

Honeywell

Midas® Gas Detector

nvoNstat

This NVO conveys the general status of the gas detector. The meanings of the 16 bits in this NVO are defined in Table 10-4. Note that the presence of a maintenance fault is not conveyed by this variable.

Table 10-4. nvoStat Description

Bit	Description	
15 (LSB)	In calibration mode	
14	In simulation mode	
13	Inhibited	
12	In warmup mode	
11	Always zero, for future expansion	
10		
9	Alarm 2 active	
8	Alarm 1 active	
7	Instrument fault fixable by new cartridge (Faults 39 - 49)	
6	Instrument fault fixable by HA Service (Faults 80, 82 - 89 or comm fail)	
5	Flow instrument fault (F81)	
4	Always zero, for future expansion	
3	Measuring unit code	Bit3=0, Bit2=0: % Volume
2		Bit3=0, Bit2=1: % LEL Bit3=1, Bit2=0: ppm
1	Always zero, for future expansion	
0 (MSB)		

nciMaxSendT, nciMinSendT

These network configuration inputs control the update rate of the network variable outputs. Every NVO will repropagate after a period of nciMaxSendT

or less. This has a default value of 60 seconds. The effective value is clamped to 180 seconds and 5 seconds, regardless of the programmed value.

Additionally, every NVO will repropagate when the status of its function block changes and nciMinSendT has expired since the last propagation. This has a default value of 5 seconds. The effective value is clamped to 10 seconds and 1 second.

nviRelay1, nviRelay2 and nviRelay3

These network variable inputs can be used to control the three internal relays from LonWorks®. However, these NVI's will have no effect unless the Midas® is configured to respond to network relay commands.

The following procedure lists how to configure the relays to be remotely controllable:

1. Hold the “s” key for 2 seconds until “SEt” is displayed.
2. Press the “3” key once to enter the setup menu. The display should show “ALm”.
3. Press the “s” key once to scroll to fault setup. The display should show “FLt”
4. Press the “3” key once to enter the fault setup menu. The display will show one of the four relay configuration codes shown in Table 5.
5. Press the “s” key as needed to select mode “nEtr”.
6. Press the “X” key repeatedly to exit the setup menu.

The various relay configuration options are listed in [Table 10-5](#).

Honeywell

Midas® Gas Detector

Table 10-5. Fault Relay Configuration options

LCD Symbol	Description	Source of Signal for Relays		
		Relay 1	Relay 2	Relay 3
1FLt	Instrument fault only	Alarm 1	Alarm 2	Inst Fault
2FLt	Separate fault relays	Any Alarm	Maint Fault	Inst Fault
CmbF	Combined fault relay	Alarm 2	Alarm 2	Any Fault
nEtr	Network remote mode	nviRelay1	nviRelay2	nviRelay3

Once the relays are configured for network remote mode, they will respond to updates to the three associated NVIs. The values ST_LOW, ST_MED, ST_HIGH and ST_ON will cause the relays to energize. The value ST_OFF will cause the relays to de-energize. The configuration settings for “normally energized” and “normally de-energized” have no effect if the relays are in network remote mode. However, the relays can still be configured for normally open or normally closed contacts by moving the jumpers on the Midas® backplane PCB.

Caution

Several failure modes will cause the relays to de-energize. These modes include power failures and CPU lockups. Furthermore, power must be removed from the Midas® for certain maintenance procedures. External equipment should be designed to prevent creation of expensive or dangerous conditions when the relays de-energize. For applications requiring a highly-reliable digital output, Honeywell Analytics recommends purchasing a dedicated DO device.

nviReset

This network variable input causes alarms and faults to be reset when it is updated with ST_LOW, ST_MED, ST_HIGH or ST_ON.

nviRequest

Updates to this NVI have the effects listed in Table 10-6. These requests are usually sent by the network management tool.

Table 10-6. Request Implementation

Request	Node Object Implementation	Sensor Object Implementation
0 RQ_NORMAL	Set to enabled	Send “no inhibit” command
1 RQ_DISABLED	Set to enabled	Send “inhibit all” command
2 RQ_UPDATE_STATUS	Retransmit status	Retransmit status
3 RQ_SELF_TEST		
4 RQ_UPDATE_ALARM		
5 RQ_REPORT_MASK	Send capability report	
6 RQ_OVERRIDE		
7 RQ_ENABLE	Set to enabled	Equivalent to RQ_NORMAL
8 RQ_RMV_OVERRIDE		
9 RQ_CLEAR_STATUS		
10 RQ_CLEAR_ALARM		Send “reset alarms and faults” command
11 RQ_ALARM_NOTIFY_ENABLE		Equivalent to RQ_NORMAL
12 RQ_ALARM_NOTIFY_DISABLE		Send “inhibit alarms” command
13 RQ_MANUAL_CTRL		
14 RQ_REMOTE_CTRL		
15 RQ_PROGRAM		
16 RQ_CLEAR_RESET		
17 RQ_RESET		
-1 RQ_NUL		

Note that disabling the node object has no practical effect. (This is implemented only for LonMark compatibility.)

nvoStatus

The meaning of the status bits in this NVO is as listed in Table 10-7.

Table 10-7. nvoStatus Implementation

LonMark Field Name	Node Object Interpretation	Sensor Object interpretation
object_id (16 bits)	0	
invalid_id		ID > 1
invalid_request	unimplemented request made	unimplemented request made
disabled	disabled	inhibited
out_of_limits		
open_circuit		
out_of_service		
mechanical_fault		instrument fault
feedback_failure		
over_range		alarm 2
under_range		
electrical_fault		maintenance fault
unable_to_measure		
comm_failure		communication failure to Midas®
fail_self_test		communication failure to Midas®
self_test_in_progress		warmup mode
locked_out		
manual_control		
in_alarm		any alarm
in_override		
report_mask	mere capability report	mere capability report
programming_mode		
programming_fail		
alarm_notify_disabled		inhibit, warmup or calibration
reset_complete		

nvoChkSum

This network variable indicates the checksum of the neuron chip and is included to confirm the correctness of the program. This will have the value 32533 for Revision 1.0 software. This is computed 45 seconds after power-up.

10.2.3 Other Characteristics

WINK Command

The LonWorks® “wink” command causes the service LED to energize for approximately six seconds.

LED Interpretation

All LED operation is inhibited for 35 seconds after power-up. This is because the neuron is held in reset until the internal ARM-7 microprocessor boots. If the neuron is “unconfigured”, after 35 seconds the yellow service LED will flash slowly. If the neuron is “configured” the service LED will be dark.

The interface contains a second LED which can be useful for debugging. This is red in color and only visible when the lid is removed from the interface. It is labeled D15 and is located immediately below the black FT-X1 transformer on the PCB. D15 will blink every second when the neuron is executing code correctly. This will be “on” most of the time if communication to the Midas® is successful. It will be “off” most of the time if communications to the Midas® is unsuccessful. Communications is certain to be unsuccessful for 190 seconds after power-up due to the Midas® boot time.



Caution

After commissioning, Echelon’s LonMaker tool will put this device into the “offline” state. In this mode, the Midas® interface will not transmit over LonWorks®. To correct this, it is necessary to click-right, on the device, select “Manage” and click on “Online”

Compatibility with old LonMaker

This device is observed to work incorrectly with Echelon LonMaker for Windows version 3.00.66. This is because it was created with NodeBuilder version 3.1 and contains an XIF file in format version 4. The problem is manifested as network variables having the wrong direction – outputs appear as inputs. The problem can be corrected by replacing a file in the network management tool with a new version. This file is “C:\LonWorks\bin\XIF32Bin.exe”. Echelon has granted permission for this file to be copied freely. A copy of this file can be obtained from Honeywell Analytics on request.

11 Troubleshooting and Fault Diagnosis

11 Troubleshooting and Fault Diagnosis

General troubleshooting guide and specific fault code table for the Midas® gas detector. Please check Honeywell Analytics' website or contact Honeywell Analytics for details on the current software revision.

Table 11-1. Fault code descriptions.

Fault code	Description	Condition	Recovery
m9	Simulated maintenance fault	User has generated a simulated fault.	Reset simulated fault.
m10	Over range.	A large concentration has been detected. The Midas® requires an independent confirmation that the gas hazard is gone.	Supply known clean air to the Midas® and clear this fault.
m11	User calibration expired.	The user specified calibration interval has elapsed.	Perform zero and span calibrations. Increase span calibration period.
m12	Cartridge expires soon.	Cartridge is old and will expire soon.	Replace the cartridge with a new cartridge.
m13	Flow error.	Midas® is no longer able to regulate flow (high or low flow condition).	Check filters and pump. Check pressure at inlet and outlet and assure they are within specification. (See Section 4.3 Sample and exhaust tubing calculations)
m14	Interferent present.	An interferent is degrading the ability of the Midas® to detect gas.	Check application.
m15	Temperature near limit.	Temperature within 2 Celsius of limit.	Check installation environment.
m16	Baseline fault.	Sensor baseline has drifted.	Check for background gas concentration, temperature or humidity fluctuations. Perform zero calibration. Replace cartridge.
m17	Inhibit timeout.	Transmitter has been in inhibit mode too long.	Resume monitoring or increase timeout value.
F39	Simulated fault	User has generated a simulated fault.	Reset simulated fault.
F40	Sensor overdosed.	Sensor has been exposed to high gas concentrations for long periods.	Replace cartridge.
F41	Baseline fault.	Sensor baseline has drifted.	Check for background gas concentration, temperature or humidity fluctuations. Perform zero calibration. Replace cartridge.
F42	Calibration expired.	Too long since last calibration.	Replace or calibrate the cartridge.
F43	Cartridge expired.	Cartridge is too old.	Replace cartridge.
F44	Cell failure.	Cartridge has failed Reflex™ check.	Replace cartridge.
F45	Stabilization timeout.	Cartridge has failed to stabilize.	If temperature or humidity shocks exist, precondition the cartridge. Check for background gas concentration. Replace cartridge.
F46	Cartridge analog failure.	Electronic Failure or gas concentration greater than full scale.	Replace cartridge.
F47	Cartridge memory invalid.	Checksum error.	Replace cartridge.
F48	Cartridge absent.	No communications.	Reseat cartridge. Replace cartridge.
F49	Cartridge wrong type.	Cartridge type found to be incorrect after boot-up.	Replace cartridge or press '3' accept if correct.
F80	Temperature limits exceeded.	Temperature is outside limits	Check installation environment.
F81	Flow fail.	Flow < 70% of nominal for 15 seconds.	Check filters. Check for kinked tubing, Replace pump.
F82	Excessive electrical noise.	Internal electronics repeatedly noisy.	Check grounding of Midas® chassis. Check termination of cable shields. Relocate the Midas® further from noise sources. Add ferrite inductors to cables.

Honeywell

Midas® Gas Detector

Fault code	Description	Condition	Recovery
F83	Pyrolyzer fail.	Pyrolyzer fails to heat.	Check electrical connection to pyrolyzer. Replace pyrolyzer. (also see Section 4.3)
F84	Misc. transmitter fault.	Transmitter is defective.	Service or replace Midas®.
F86	Coprocessor fail	Coprocessor is damaged.	Contact Honeywell Analytics Service.
F87	Pyrolyzer temp limits exceeded	Pyrolyzer temperature exceeded.	Clean pyrolyzer cooling vents. Contact Honeywell Analytics Service.
F88	Pyrolyzer heater fail	Pyrolyzer heater failed.	Contact Honeywell Analytics Service. Replace the pyrolyzer.
F89	Pyrolyzer power unreg	Target power not achieved within specified time span.	Check the 24 volt power supply. If it is not 24 VDC \pm 2.4, contact Honeywell Analytics Service. Replace pyrolyzer.
F90	Pyrolyzer heater mismatch	Different pyrolyzer type required	Contact Honeywell Analytics Service.
F91	HTP module required	Check that MIDAS-S-CFX or MIDAS-E-CFX is installed for the high temperature pyrolyzer version	Change to HT Pyrolyzer
F92	NP1/OP3 pyrolyzer module failure	Data value: 0x0800 NP1/OP3 pyrolyzer failed to get up to temperature	Replace pyrolyzer heater (only for the OP3 pyrolyzer)
		Data value: 0x1000 NP1/OP3 pyrolyzer flow is out-of-range	Check flow connections between Midas and NP1/OP3 pyrolyzer
		Data value: others NP1/OP3 pyrolyzer internal failure	Contact Honeywell Analytics Service.

“Hot” and “Cool” messages are informational events that can be generated under two conditions:

1. Immediately after the detector powers up.
2. When the state changes from cool to hot or hot to cool.

“Hot” means the temperature inside the cartridge is at 40°C or above. “Cool” means the temperature inside the cartridge is below 40°C. In both cases the event data field will list the actual temperature at the time of the event.

12 REFLEX[®]

12 REFLEX®

Midas® uses patented Honeywell Analytics technology to continuously monitor the health check status of specific electrochemical cells and alert the user if a cell enters a variety of fault conditions (such as open or short circuit etc.) which would leave the cell unable to detect gas and raise an appropriate alarm signal.

REFLEX® overcomes this unseen failure mode by applying periodically a special electronic pulse to the cell and reviewing the 'echo' from the cell as it responds to the applied signal. If the cell is deteriorating within certain pre-set limits based on the received signals then Midas® will decrease the REFLEX® sampling interval in order to establish the actual viability of the cell. Within a relatively short time, Midas® will be able to alert the user via fault codes that the electrochemical cell is likely to be requiring replacement and is possibly unable to correctly detect gas.

REFLEX® is not required for pellistors or oxygen electrochemical cells as these sensor cartridges provide alternative electronic means to indicate open circuits and other sensor cartridge damage issues.

13 Internal Web Server

13 Internal Web Server

The Midas® gas detector unit utilizes an Ethernet port with the TCP/IP protocol as standard. The Midas® can function as a HTML web page server and these web pages can be viewed on external computer equipment (PC, PocketPC etc.) by using a standard software program, i.e.; Microsoft Internet Explorer. These web pages replicate the user interface on the front panel of the Midas® in a more flexible and friendly format for diagnostic and data entry purposes. The web pages also contain additional features not available via the keypad.

This procedure explains how to view web pages for a single Midas® which is connected to a single PC only. Of course it is possible to connect hundreds of Midas® units to an Ethernet network. More information may be required from the local IT department and Honeywell Analytics as appropriate.

13.1 Physical Network Components

The Ethernet 100BaseT physical network is intended to connect computers to other computers through hubs. For this reason, a Midas® cannot communicate directly with a PC using a standard cable. This problem can be overcome by using a special “cross-over” Ethernet cable or by using a ‘hub’ or ‘switch’ and two standard (straight through wire connections) Ethernet cables. An example of a cross-over cable is the Belkin A3X126 family. An example of an Ethernet switch is the Linksys SD205.

13.2 Internet Settings

Communications requires knowledge of the IP address and netmask of both the Midas® and the PC. Unless the Midas® is connected to a network

with a DHCP server, the addresses must be set manually. To view or set the IP address of the Midas®, see [Section 7.2.6](#). The procedure for setting the IP address of a PC is detailed in the following example using a PC loaded with Microsoft™ Windows XP and Internet Explorer version 5.0 or higher as illustrated by [Diagram 13-1](#). In the usual case the netmask for both computers should be set to 255.255.255.0. The most-significant three bytes of the IP address must be identical and the least-significant byte must be unique. For example, if the IP address of the Midas® was set to 169.254.60.47 (the factory default) then an appropriate IP address for the PC would be 169.254.60.42.

Diagram 13-1. IP Address setting in Windows XP.

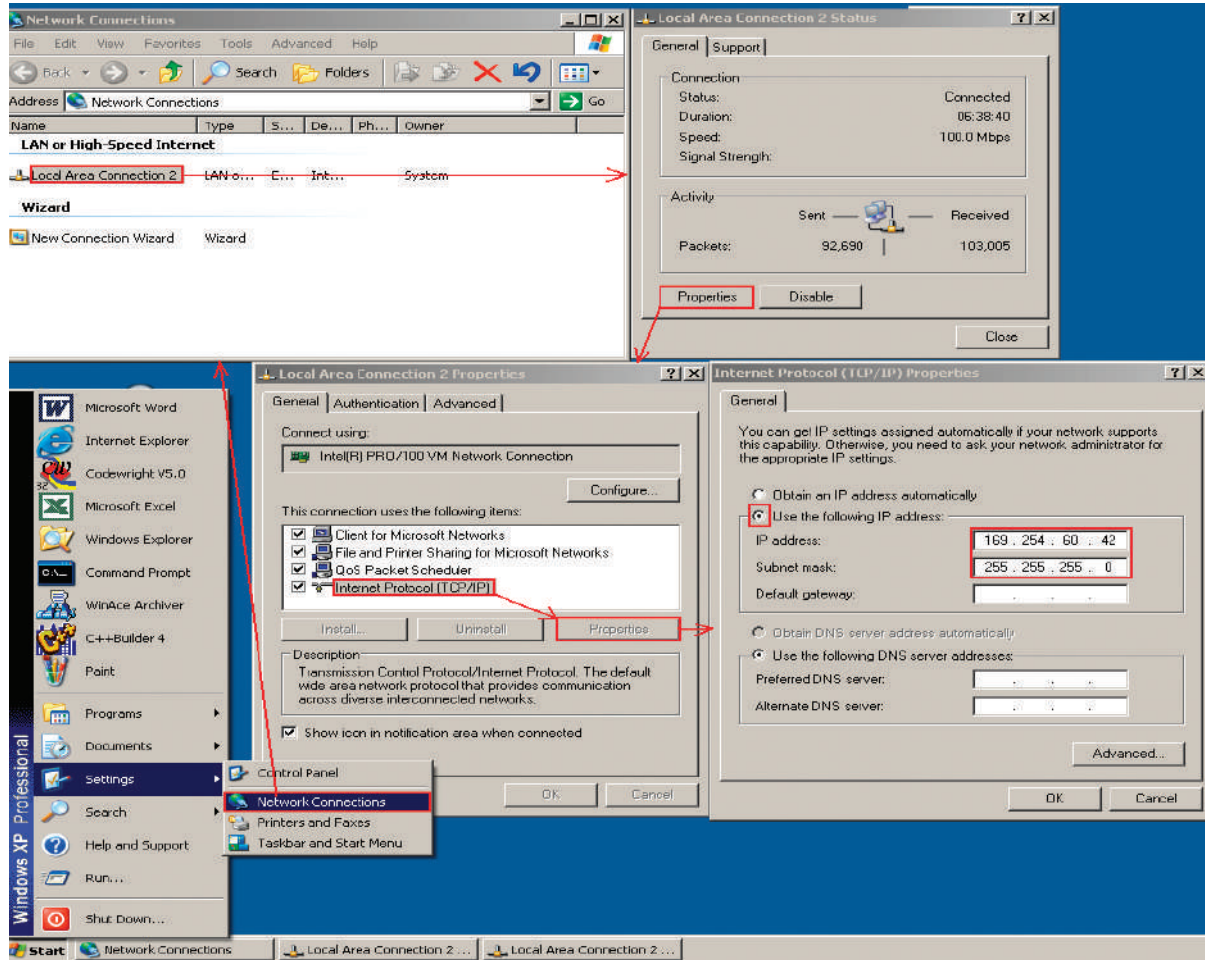

Honeywell

Midas® Gas Detector

13.3 Running the Web Browser

Start Microsoft™ Internet Explorer or similar web browser. Set the URL to “http://xxx.xxx.xxx.xxx” where the “xxx” fields are replaced with the IP address of the Midas®. A screen similar to Diagram 13-2 should be displayed. The status and configuration of the Midas® can be viewed and set by clicking on the appropriate links.

Diagram 13-2. Midas® Default web page.

The screenshot shows the Honeywell Midas Gas Detector web interface in a browser window. The browser address bar shows the URL http://169.254.60.47/. The page title is "Midas Unit #M12340338, Honeywell Analytics". The interface includes a navigation menu on the left with sections for General, Configuration, Calibration, and Test. The main content area is titled "Status:" and contains several data tables and a "Reset" button.

Name:		HA-M12340338	
Serial Number:	M12340338	Cartridge Serial Number:	12K50491
Location:	MIDAS Gas Detector		
IP Address:	169.254.60.47		

General:	
Gas:	Hydrogen
Concentration:	0.0 %LEL
Alarm:	Normal
Fault:	Normal
Flow:	5.17 cc/min
Pyrolyzer:	---
Cartridge S/N:	12K50491
Cartridge Expires:	9/17/2017

Alarm Configuration:	
Alarm Level 1:	10.0 %LEL Normal (up)
Alarm Level 2:	20.0 %LEL Normal (up)
Latching Alarms:	YES
Alarm Relay State:	Normally De-Energized

Pyrolyzer Status:	
Flow Rate:	-N/A-
Temperature:	-N/A-

Fault Configuration:	
Relay Configuration:	Instrument
Latching Faults:	YES
Fault Relay State:	Normally Energized

Date/Time:	
Current Time:	8:50 PM
Current Date:	9/26/2012
Date Format:	MM/DD/YYYY

Calibration:	
Last Zero Calibration:	7/9/2012
Last Span Calibration:	7/9/2012
Calibration Due:	171 days
Cartridge Expires:	1817 days

Software Version:	
Main:	2.12 build 5
CO-processor:	125
Sensor:	14
Pyrolyzer:	0

On the Status web page, all faults and alarms are indicated as well as real-time concentration reading. A fault or alarm can be reset from within the web page by clicking the “Reset” button. If the fault condition is still present, the fault status will be indicated again on the web page. Information regarding alarm settings, calibration history and software version are all contained in the status web page.

Diagram 13-3. Event History.

Honeywell
MDA Scientific
Midas Gas Detector
Midas Ver 2.12 build 0

Name: HA-M12340338
Serial Number: M12340338 Cartridge Serial Number: 12K50491
Location: MIDAS Gas Detector
IP Address: 169.254. 60. 47

Event History: Events 91 to 100 of 130

Timestamp	Type	Description	Gas	Conc/Data	
Thu Sep 20 19:08:51 2012	Alarm	ALM2: Alarm Level 2	COS	260	Details
Thu Sep 20 19:09:33 2012	Alarm	ALM1: Alarm Level 1	COS	150	Details
Thu Sep 20 18:53:46 2012	Alarm	RST2: Reset Alarm Level 2	COS	0	Details
Thu Sep 20 18:53:45 2012	Alarm	RST1: Reset Alarm Level 1	COS	0	Details
Thu Sep 20 18:53:29 2012	Reset	RST: Reset All Faults and Alarms via Web	COS	0	Details
Thu Sep 20 18:51:46 2012	COOL	COOL: The cartridge temperature	COS	26.2	
Thu Sep 20 18:51:14 2012	LOAD	SAME CELL: Load Data: 12K51530	COS		
Thu Sep 20 18:47:39 2012	Fault	F 48: Cartridge Absent	COS	3.8	
Thu Sep 20 18:41:49 2012	Alarm	ALM2: Alarm Level 2	COS	341	Details
Thu Sep 20 18:30:26 2012	Reset	RST: Not confirmed, returned to previous values	COS		

Make Printable Version << Page 4 >> Go >>

All Midas® events including calibrations, faults, and alarms are data logged with a timestamp, description and category code. The events are color-coded to allow a quick overview of the type of event logged.

Color	Event Type
Green	Reset
Red	Alarms
Yellow	Fault
White	Informational

Event History will store approximately 400 events, overwriting the oldest with the newest data. 30 seconds of data is stored for each alarm event - 15 seconds before the event and 15 seconds after.

The “Send to Print”, will generate a printed version of the event log by page or the complete listing (see Diagram 13-5).

The “Details” button allows access to a graphical display of gas concentration versus time elapsed (see Diagram 13-6).

Diagram 13-4. Event Log Printing Dialog.

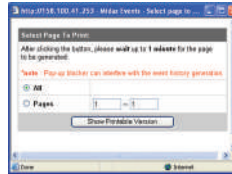

Diagram 13-5. Event Log Output

Midas Events - Windows Internet Explorer
 http://169.254.60.47/MidasEventsPrint.htm

Name:	HA-M12340338		
Serial Number:	M12340338	Cartridge Serial Number:	12K50491
Location:	MIDAS Gas Detector		
IP Address:	169.254.60.47		

Event History: Print... Close Window

No	Timestamp	Type	Description	Gas	Conc/Data
Page 1					
1	Wed Sep 26 20:40:58 2012	HOT	HOT : The cartridge temperature	H2	40.0
2	Wed Sep 26 20:38:35 2012	COOL	COOL : The cartridge temperature	H2	38.9
3	Wed Sep 26 20:38:07 2012	LOAD	SRME CELL : Load Data : 12K50491	H2	
4	Wed Sep 26 20:26:43 2012	HOT	HOT : The cartridge temperature	H2	41.4
5	Wed Sep 26 20:26:13 2012	LOAD	SRME CELL : Load Data : 12K50491	H2	
6	Wed Sep 26 20:12:44 2012	HOT	HOT : The cartridge temperature	H2	40.0
7	Wed Sep 26 19:53:29 2012	SETUP	SET : Setting up Inhibit	H2	
8	Wed Sep 26 19:53:06 2012	SETUP	SET : Setting up Inhibit	H2	
9	Wed Sep 26 19:39:58 2012	COOL	COOL : The cartridge temperature	H2	26.2
10	Wed Sep 26 19:39:28 2012	LOAD	SRME CELL : Load Data : 12K50491	H2	

Done Internet | Protected Mode: Off 120%

Note

Pop-up blockers may interfere or prevent proper operation.

Diagram 13-6. Gas Concentration Graph

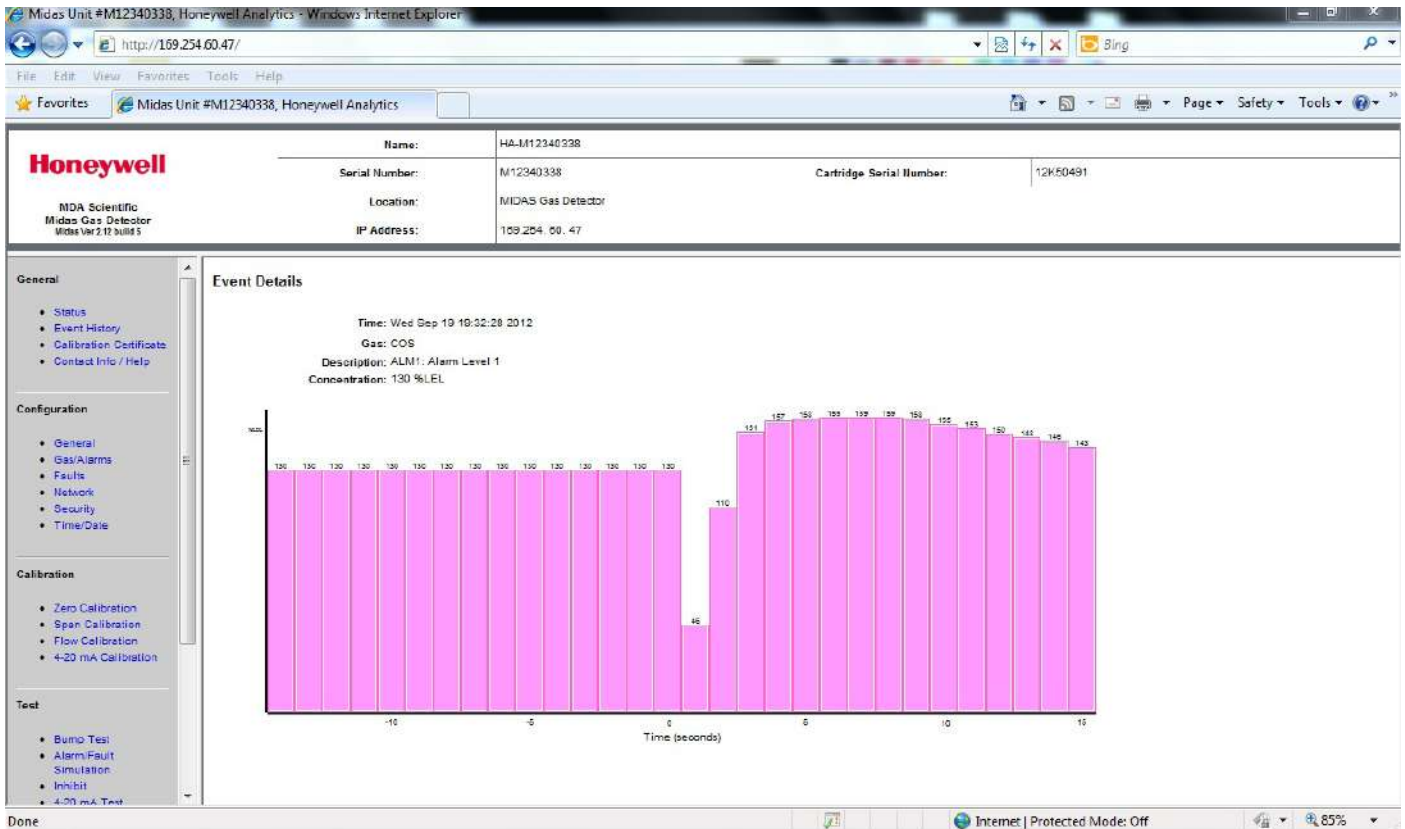

This web page is accessed from the “Details” button from the Event History page. The gas concentration levels for a given alarm are displayed for a period of 30 seconds - 15 seconds before and 15 seconds after the alarm occurred.

Honeywell

Midas[®] Gas Detector

Diagram 13-7. Calibration Certificate.

Honeywell
MDA Scientific
Midas Gas Detector
Midas Vvr 2.12 build 6

Name:	HA-M12340338		
Serial Number:	M12340338	Cartridge Serial Number:	12K50491
Location:	MIDAS Gas Detector		
IP Address:	169.254.60.47		

General

- Status
- Event History
- Calibration Certificate**
- Contact Info / Help

Configuration

- General
- Gas/Alarms
- Faults
- Network
- Security
- Time/Date

Calibration

- Zero Calibration
- Span Calibration
- Flow Calibration
- 4-20 mA Calibration

Test

- Bump Test
- Alarm/Fault Simulation

Honeywell Analytics Ltd
4 Stnford Rd
Poole, Dorset
United Kingdom
BH17 0RZ
Tel +44 1202 676161
Fax +44 1202 678011
Email: sales@zeana.com
Web: <http://www.honeywellanalytics.com/>

Honeywell

Electronic Certificate of Calibration

Part Number: MIDAS-E-LEL R3
Serial Number: 12K50491
Calibration Date: Mon Jul 9 09:04:36 2012
Gas Type: H2, 0 - 100.0 %LEL

This sensor cartridge was calibrated using equipment which is subject to regular verification and whose calibration is traceable to national standards. Gases for which traceability to national standards is not available have been obtained from reputable sources.

The calibration was carried out in accordance with the general requirements of the company's BS EN 9001:2000 approval.

Records are kept for all sensor cartridge calibrations and copies are available on request.

An electronic copy of the original sensor calibration certificate can be accessed from this section and printed for audit purposes.

Honeywell

Midas[®] Gas Detector

Diagram 13-8. Contact Information / Help.

The screenshot shows a web browser window displaying the Honeywell Midas Gas Detector interface. The browser address bar shows the URL <http://169.254.60.47/>. The page title is "Midas Unit #M12340338, Honeywell Analytics".

The interface includes a header with the Honeywell logo and the text "MIDA Scientific Midas Gas Detector Midas Ver 1.12 build 5". Below this is a table with the following information:

Name:	HA-M12340338		
Serial Number:	M12340338	Cartridge Serial Number:	12K56491
Location:	MIDAS Gas Detector		
IP Address:	169.254. 00. 47		

The main content area is divided into sections:

- General:**
 - Status
 - Event History
 - Calibration Certificate
 - [Contact Info \(Help\)](#)
- Configuration:**
 - General
 - Gas/Alarms
 - Faults
 - Network
 - Security
 - Time/Date
- Calibration:**
 - Zero Calibration
 - Span Calibration
 - Flow Calibration
 - 4-20 mA Calibration
- Test:**
 - Bump Test
 - Alarm/Fault Simulation

The **Contact Information:** section contains the text: "Current contact information can be found at the Honeywell Analytics web site. Please visit us online at: <http://www.honeywellanalytics.com>. Requires a connection to the internet."

The **Fault Information:** section contains a table with the following data:

Number	Name	Data Field	Condition	Recovery
m9	Simulated m Fault	n/a	User enters simulation mode	Reset simulated fault
m10	Over Range	Peak concentration	Large concentration of gas has been detected. The Midas requires an independent confirmation that the gas hazard is gone.	Supply known clean air to the Midas and clear the fault.
m11	User Calibration Expired	Days until fault	The user specified calibration interval has elapsed.	Perform zero and span calibrations. Increase span calibration period. (zero days = disabled)
m12	Cartridge Expires Soon	Days until fault	Cartridge is old and will expire soon.	Replace the cartridge with a new cartridge.
m13	Flow Low	Flow (cc/min)	Midas is no longer able to regulate the flow.	Check filters and pump.
m14	Interferent Present	A/D counts	An interferent is degrading the ability of the Midas to detect gas.	Check application.
m15	Temperature Near Limit	Temperature (C)	Temperature is within 2 C of limit.	Check installation environment
m16	Baseline Near Limit	A/D counts	Sensor baseline has drifted.	Check for background gas concentration, temperature or humidity fluctuations. Perform zero calibration. Replace cartridge.
m17	Inhibit Timeout	n/a	Transmitter has been in inhibit mode too long.	Resume monitoring or increase timeout value.
m18	Software Mismatch	Software Version	Coprocessor firmware or bootloader too old	Update firmware

This page provides a listing of the fault codes and recovery information as well as a link to Honeywell Analytics website.

Honeywell

Midas® Gas Detector

Diagram 13-9. General Configuration.

The screenshot shows a web browser window displaying the Honeywell Midas Gas Detector configuration page. The browser title is "Midas Unit #M12340338, Honeywell Analytics - Windows Internet Explorer" and the address bar shows "http://169.254.60.47/". The page features a navigation menu on the left with sections for General, Configuration, Calibration, and Test. The main content area is titled "General Configuration:" and contains a "Setup:" panel with the following fields:

Name:	HA-M12340338		
Serial Number:	M12340338	Cartridge Serial Number:	12K50491
Location:	MIDAS Gas Detector		
IP Address:	169.254.60.47		

The "Setup:" panel includes a text input field for "Location" containing "MIDAS Gas Detector", a "Date Format" section with radio buttons for "MM/DD/YYYY" (selected) and "DD/MM/YYYY", and a "Backlight" section with radio buttons for "Classic" and "Multi-Color" (selected). "Accept" and "Reset" buttons are located at the bottom of the "Setup:" panel.

This panel allows the user to customize the location identifier for the individual Midas® units with more detailed text. Enter the text and click Accept to update the Midas® web page. The date format can be selected to suit the regional preference.

Honeywell

Midas® Gas Detector

Diagram 13-10. Gas / Alarm Configuration.

The screenshot shows a web browser window displaying the configuration page for a Honeywell Midas Gas Detector. The browser address bar shows the URL `http://169.254.60.47/`. The page header includes the Honeywell logo and the text "MDA Scientific, MIDAS Gas Detector, Midas Ver 2.12 build 3".

The main content area is titled "Gas / Alarm Configuration:" and contains a "Setup Gas:" form. The form fields are as follows:

Name:	HA-M12340338		
Serial Number:	M12340338	Cartridge Serial Number:	12K50491
Location:	MIDAS Gas Detector		
IP Address:	169.254.60.47		

Gas:	Hydrogen		
Range:	0.0 ~ 100.0	%LEL	
Alarm Level 1:	10.0	%LEL	<input checked="" type="radio"/> Normal (up) <input type="radio"/> Depletion (down)
Alarm Level 2:	20.0	%LEL	<input checked="" type="radio"/> Normal (up) <input type="radio"/> Depletion (down)
Alarm Delay:	3	seconds	
Latching Alarms:	<input checked="" type="checkbox"/>		
Relay State:	<input checked="" type="radio"/> Normally De-Energized <input type="radio"/> Normally Energized		
Calibration Period:	180	days	

Buttons at the bottom of the form: Accept, Reset, Change to Default.

The left sidebar contains navigation menus for "General", "Configuration", "Calibration", and "Test". The "Configuration" menu is expanded, showing "Gas/Alarms" as the selected option.

The Gas/Alarm Configuration page enables users to select the desired gas calibration. It also permits setting alarm levels and other parameters. Additionally, alarms may be set to trigger on decreasing concentration -- this is useful with oxygen.

An alarm delay of 0 to 60 seconds can be set up in order to give a programmable delay time before the alarm signal is processed; this can be used to prevent nuisance alarms in certain conditions. Alarms can be set latching which requires direct operator intervention to reset the alarm once activated. The User Calibration Period is a reminder of when a calibration message will be broadcast by the Midas® via the LCD display, analog or digital outputs. This can set to a custom period or if set to zero, no reminder will be activated. The factory default is set for 6 months (180 days).

Diagram 13-11. 4-20 mA output configuration.

The screenshot shows a web browser window with the URL <http://169.254.60.15/>. The page title is "Midas Unit #V16080403, Ho...". The main content area is titled "4-20 mA Output Configuration:" and contains a "Setup mA output range:" section with the following table:

Setup mA output range:		
Gas conc. corresponding to 4 mA:	<input type="text" value="0.0"/>	%VOL
Gas conc. corresponding to 20 mA:	<input type="text" value="25.0"/>	%VOL

Below the table are three buttons: "Accept", "Reset", and "Change to Default".

The left sidebar contains the following navigation links:

- General
 - Status
 - Event History
 - Calibration Certificate
 - Contact Info / Help
- Configuration
 - General
 - Gas/Alarms
 - 4-20 mA Output
 - Faults
 - Network
 - Security
 - Time/Date
- Calibration
 - Zero Calibration
 - Span Calibration
 - Flow Calibration
 - 4-20 mA Calibration
- Test
 - Bump Test
 - Alarm/Fault Simulation
 - Inhibit
 - 4-20 mA Test

This page enables the user to configure the 4-20mA output scale. The default value is 0 from the measuring range. When replacing a sensor cartridges with a different cartridge type, these values will be changed to the default. However, when replacing a sensor cartridge with the same type of cartridge, no change of the mA output scale is required.

Diagram 13-12. Fault and Relay Configuration.

Honeywell
Scientific
Midas Gas Detector
Midas Ver 1.15 build 2

MDA

Name: HA-0
Serial Number: 0
Location: MIDAS Gas Detector
IP Address: 169.254.60.23
Cartridge Serial Number: 13K74581

General

- Status
- Event History
- Calibration Certificate
- Contact Info / Help

Configuration

- General
- Gas/Alarms
- 4-20 mA Output
- Faults
- Network
- Security
- Time/Date

Calibration

- Zero Calibration
- Span Calibration
- Flow Calibration
- 4-20 mA Calibration

Test

- Bump Test
- Alarm Fault Simulation
- Inhibit
- 4-20 mA Test

Fault and Relay Configuration:

Setup:

Latching Faults:

Fault Relay State: Normally De-Energized
 Normally Energized

Relay Configuration:	Relay 1	Relay 2	Relay 3
<input checked="" type="radio"/> Instrument Fault Only	Alarm 1	Alarm 2	Instrument Fault
<input type="radio"/> Separate Fault Relays	Any Alarm	Maintenance Fault	Instrument Fault
<input type="radio"/> Combined Fault Relay	Alarm 1	Alarm 2	Any Fault
<input type="radio"/> Modbus/TCP Remote	Relays respond to writes to Modbus holding registers only		

Fault m12 Occurrence: Recur Weekly
 Only Once
 Never Occur

Temperature Fault: (m15, F80) Enable
 Disable

Accept Reset

This page enables the user to select latching fault mode; normally energized or de-energized mode for the relays. The relays can be configured in 4 states. Three states allow local response and one allows remote Modbus/TCP control. This page also allows the user to configure the reoccurrence frequency for the “m12” = “Cartridge Expires Soon” notifications. The temperature fault can also be configured here (to enabled or disabled).

Honeywell

Midas® Gas Detector

Diagram 13-13. Network Configuration.

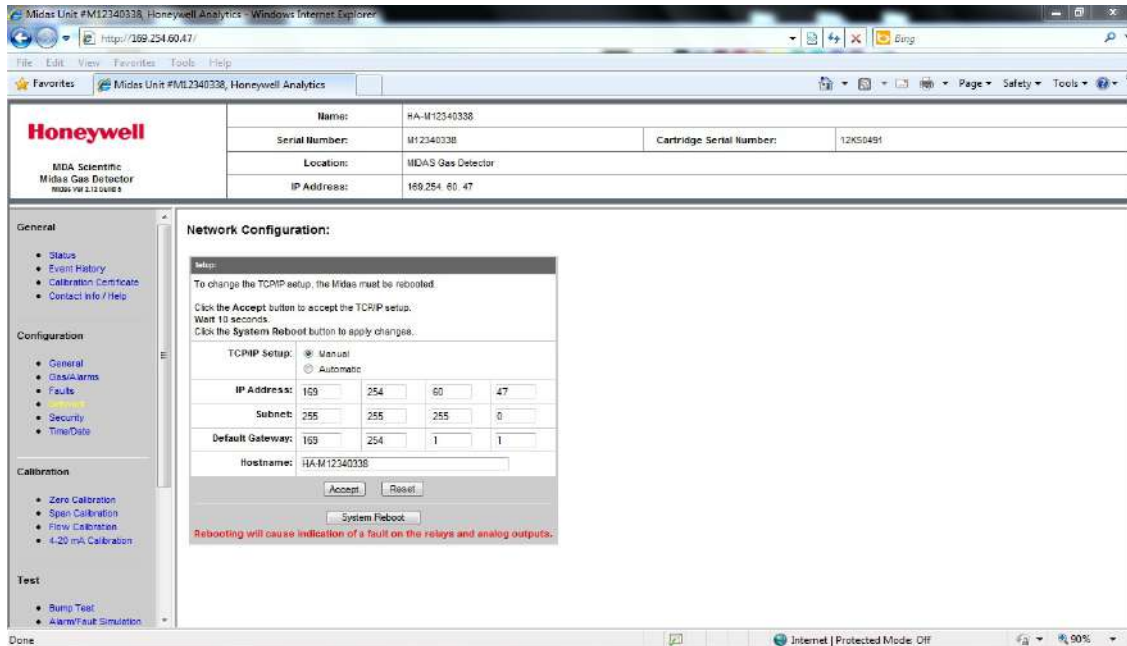

The Network setup enables a manual or automated selection of the Midas® unit's IP and subnet address. Additional information regarding the gateway address and an identifier name for the network can be added on this page. The Midas® DHCP client reports the hostname over the network to a domain name server. The default hostname is based on the Midas® serial number and will be seen as "HA-<<<Midas unit serial number>>>" (Example: HA-M0516146). Invalid hostnames are automatically reformatted for validity.

One additional network setting, which controls the web access level, is available through the local user interface. The two web access levels are Full Control (which allows the user to check status, make configuration changes, perform calibrations, and perform tests through the web interface) and Read Only (which does not allow configuration, calibration, or tests to be performed through the web interface). In read-only mode, the web buttons at the bottom of the screen will be greyed-out and will not be selectable. See Table 6-3 *Set-up menu overview*.

Note

In order for the changes to take effect, the System Reboot button should be activated. When this takes place, the Midas® unit will be temporarily offline from detecting gas while it recovers and a fault condition will be transmitted via any connected energized relays or analog connection.

Diagram 13-14. Security.

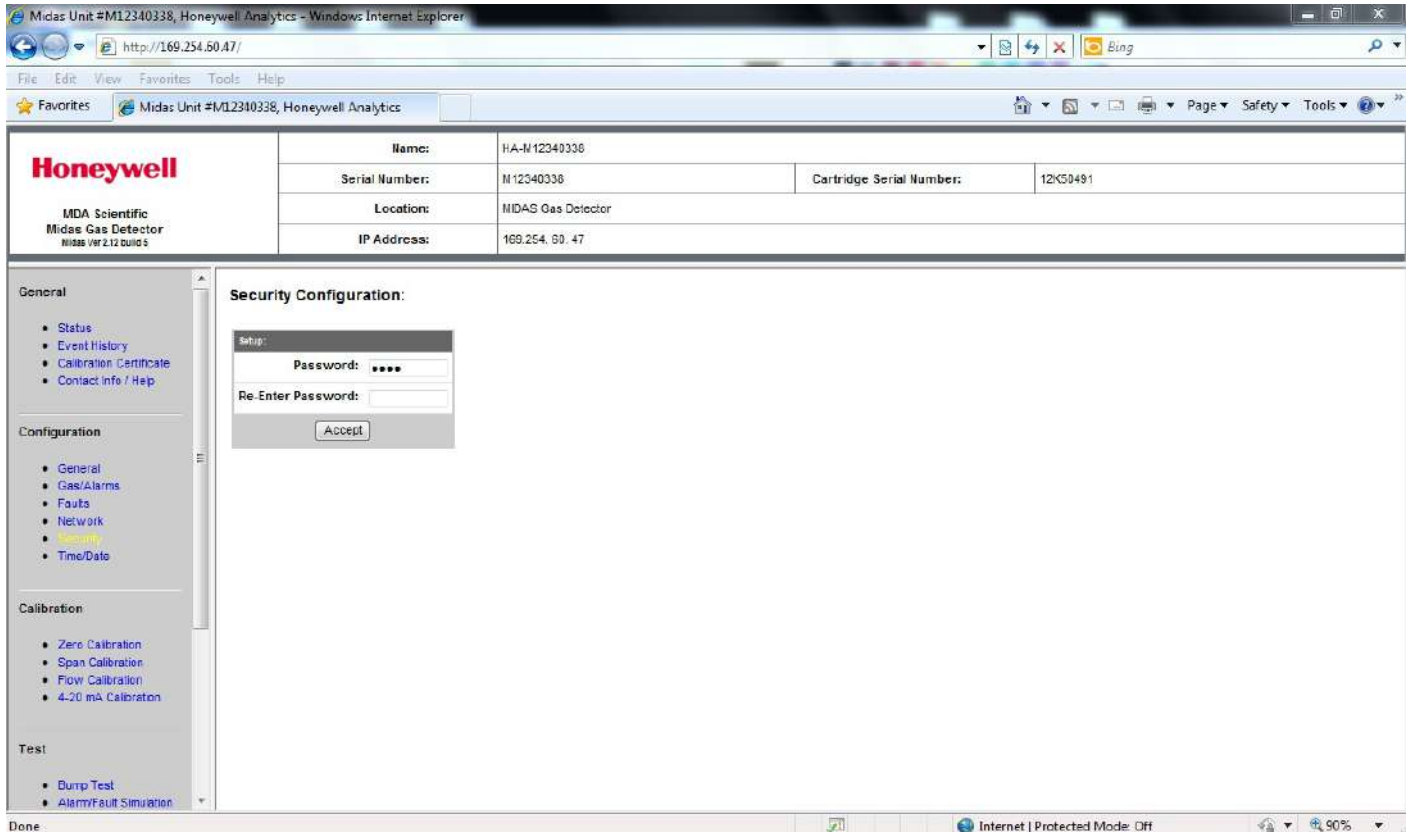

A 4 digit numerical code can be entered to prevent unauthorized changes to the Midas® transmitter; this code can also be entered or changed via the keypad directly on the transmitter. Once activated, each time the user attempts to access a restricted area of the Midas® menu (either directly via the LCD/keypad or via the webpage) they will be prompted to enter the supervisor code.

Note

The passcode should be recorded in a separate database along with the serial number for each Midas® unit. Should the passcode be lost or forgotten, Honeywell Analytics is not responsible for any lost time or inconvenience. To recover lost passcodes please contact your Honeywell Analytics Service Representative.

Honeywell

Midas® Gas Detector

Diagram 13-15. Time and Date.

The screenshot shows a web browser window displaying the configuration page for a Honeywell Midas Gas Detector. The browser address bar shows the URL <http://169.254.60.47/>. The page header includes the Honeywell logo and the text "MDA Scientific Midas Gas Detector Midas Ver 2.12 build 5".

Name:	HA-M12340338		
Serial Number:	M12340338	Cartridge Serial Number:	12K50491
Location:	MIDAS Gas Detector		
IP Address:	169.254.60.47		

The main content area is titled "Time & Date Configuration:" and contains a "Setup:" section with the following text: "Time does not automatically update with regional daylight savings changes. Time is entered in 24 hour format." Below this text are input fields for Year (2012), Month / Day (9 / 26), and Hour : Minute (21 : 18). At the bottom of the setup section are three buttons: "Change", "Reset", and "Synchronize with Computer".

The left sidebar contains a navigation menu with the following sections:

- General
 - Status
 - Event History
 - Calibration Certificate
 - Contact Info / Help
- Configuration
 - General
 - Gas/Alarms
 - Faults
 - Network
 - Security
 - Time/Date
- Calibration
 - Zero Calibration
 - Span Calibration
 - Flow Calibration
 - 4-20 mA Calibration
- Test

The time and date can be configured via this web page. In addition the Midas® can have its time synchronized automatically with the web browsing computer's own clock by selecting the "Synchronize with Computer" button; this useful feature will ensure any time changes are automated on a site wide basis.

Diagram 13-16. Zero Calibration.

The screenshot shows the Honeywell Midas Gas Detector web interface. The browser address bar displays `http://169.254.60.23`. The page title is "Midas Unit #0, Honeywell ...".

Header Information:

Honeywell Scientific Midas Gas Detector Midas Ver 1.16 build 2	Name: HA-0	
	Serial Number: 0	Cartridge Serial Number: 13K74581
	Location: MIDAS Gas Detector	
	IP Address: 169.254.60.23	

General

- Status
- Event History
- Calibration Certificate
- Contact Info / Help

Configuration

- General
- Gas/Alarms
- 4-20 mA Output
- Faults
- Network
- Security
- Time/Date

Calibration

- Zero Calibration
- Span Calibration
- Flow Calibration
- 4-20 mA Calibration

Test

- Bump Test
- Alarm/Fault Simulation
- Inhibit
- 4-20 mA Test

Zero Gas Calibration:

Step:	Status:
Zero Calibration:	Concentration Reading: -130 ppm
Save New Values:	
Set Inhibit:	

Start

Instructions:
Press Start to enter zero gas calibration mode.

Note: Unit must be in normal monitoring mode to enter zero gas calibration mode.

Inhibit Setting:

Exit with Inhibit ON	<input type="radio"/> Yes <input checked="" type="radio"/> No	Accept
Inhibit Timeout:	30 Minutes	Accept

A zero gas calibration can be initiated via the web page and is ideal for when access to the Midas® unit is restricted due to its location. Follow the on screen instructions to perform the calibration sequence correctly.

Diagram 13-17. Span Calibration.

The screenshot shows the Honeywell Midas Gas Detector web interface. The browser address bar displays 'http://169.254.60.23' and the page title is 'Midas Unit #0, Honeywell...'. The interface includes a navigation menu on the left with sections for General, Configuration, Calibration, and Test. The main content area is titled 'Span Gas Calibration:' and contains several sections:

- Device Information:** A table showing Name: HA-0, Serial Number: 0, Cartridge Serial Number: 13K74681, Location: MIDAS Gas Detector, and IP Address: 169.254.60.23.
- Span Gas Calibration:** A table with fields for Step, Set Span Gas Information, Span Calibration, Save New Values, Purging Time, and Set Inhibit.
- Status:** A table showing Concentration Reading: -100 ppm and Purging Remaining Time.
- Instructions:** A 'Start' button and text: 'Instructions: Press Start to enter span gas calibration mode.' and 'Note: Unit must be in normal monitoring mode to enter span calibration mode.'
- Span Gas Settings:** A form with fields for Gas (Nitrous Oxide), Gas Type (Humid/Dry), and Concentration (500 ppm), each with an 'Accept' button.
- Purging Setting:** A form with a Purging Time field set to 3 Minutes and an 'Accept' button.
- Inhibit Setting:** A form with 'Exit with Inhibit ON' (Yes/No) and 'Inhibit Timeout' (30 Minutes), each with an 'Accept' button.

The span calibration sequence can be performed using the web page interface. Parameters such as the gas humidity and the gas type can be selected dependent on the gases available per sensor cartridge. Follow the on screen sequence of instructions to perform the span calibration correctly. See [Appendix B](#) for a list of recommended test gases.

Honeywell

Midas® Gas Detector

Diagram 13-18. Flow Calibration.

The screenshot displays the Honeywell Midas Gas Detector web interface in Internet Explorer. The browser address bar shows the URL <http://169.254.60.47/>. The page header includes the Honeywell logo and the text "MDA Scientific Midas Gas Detector Midas Ver 2.12 build 5".

The main content area is titled "Flow Calibration:" and contains the following information:

Name:	HA-M12340338		
Serial Number:	M12340338	Cartridge Serial Number:	12K50491
Location:	MIDA3 Gas Detector		
IP Address:	169.254.60.47		

The "Flow Calibration:" section is divided into two columns:

Step:	Status:
Characterize Baseline:	Set Point 1 Flow: 499 cc/min
Characterize Setpoint 1:	Set Point 2 Flow: 600 cc/min
Characterize Setpoint 2:	Current Flow Rate: 491 cc/min
Save New Values:	

Below the flow calibration table, there is a "Start" button and an "Instructions" box that reads: "Press Start to enter flow calibration mode." To the right of the instructions is a "Flow Set Points:" section with two input fields and "Accept" buttons:

Set Point 1:	499	Accept
Set Point 2:	600	Accept

Below the set points is a "Flow Adjust:" section with "Increase" and "Decrease" buttons.

The left sidebar contains a navigation menu with the following sections:

- General
 - Status
 - Event History
 - Calibration Certificate
 - Contact Info / Help
- Configuration
 - General
 - Gas/Alarms
 - Faults
 - Network
 - Security
 - Time/Date
- Calibration
 - Zero Calibration
 - Span Calibration
 - Flow Calibration
 - 4-20 mA Calibration
- Test

The status bar at the bottom of the browser shows "Done", "Internet | Protected Mode: Off", and a zoom level of 95%.

The Midas® transmitter can have its flow settings calibrated and changed using the web page interface. Options to set two flow set points are available. Follow the on screen sequence of messages to perform the flow calibration correctly.

Honeywell

Midas® Gas Detector

Diagram 13-19. 4-20mA Calibration.

The screenshot shows the Honeywell Midas Gas Detector web interface in Internet Explorer. The browser address bar shows the URL <http://169.254.60.47/>. The page title is "Midas Unit #M12340338, Honeywell Analytics".

Honeywell
MDA Scientific
Midas Gas Detector
Midas (Var 2.12 build 5)

Name:	HA-M12340338		
Serial Number:	M12340338	Cartridge Serial Number:	12K50491
Location:	MIDAS Gas Detector		
IP Address:	169.254.60.47		

4-20 mA Calibration:

Step:	Status:
Characterize 4 mA: Awaiting Input	4-20 mA Reading: 4-20
Characterize 20 mA:	
Save New Values:	

Start

Instructions:
Press Start to enter 4-20 mA calibration mode. An external current meter will be needed to calibrate the 4-20 mA output.

Note: Unit must be in normal monitoring mode to enter 4-20 mA calibration mode.

Adjust 4-20 mA:
Increase
Decrease

Done | Internet | Protected Mode: Off | 95%

The analog output from the Midas® can be calibrated for integration with an external control device. Follow the on screen sequence of messages to perform the 4-20mA calibration correctly.

Diagram 13-20. Bump Test.

The screenshot shows a web browser window displaying the Honeywell Midas Gas Detector configuration page. The browser address bar shows the URL <http://169.254.60.47/>. The page header includes the Honeywell logo and the text "MDA Scientific Midas Gas Detector Midas Ver 2.12 build 5".

Name:	HA-M12340338		
Serial Number:	M12340338	Cartridge Serial Number:	12K50491
Location:	MIDA3 Gas Detector		
IP Address:	169.254.60.47		

The main content area is titled "Bump Test" and contains a "Perform Test:" section. The text reads: "The inhibit icon is also displayed indicating that no alarm outputs will be generated during this process. Apply the bump test gas and the display will show the measured gas concentration." Below this is a red note: "Note: Unit must be in normal monitoring mode." A table displays the current status:

Gas Concentration:	0.0	%LEL
Flow:	488	cc/min

At the bottom of the table is a button labeled "Enter Bump Test Mode".

The left sidebar contains a "Configuration" menu with the following items: General, Gas/Alarms, Faults, Network, Security, and Time/Date. Below this is a "Calibration" section with: Zero Calibration, Span Calibration, Flow Calibration, and 4-20 mA Calibration. The "Test" section includes: Bump Test, Alarm/Fault Simulation, Inhibit, and 4-20 mA Test. The "Authorized Users" section is also visible at the bottom of the sidebar.

A simple gas checking test or “Bump Test” can be applied using the web page interface. The bump test confirms that the sensor can still respond to an applied concentration of gas but is not a formal calibration. See [Appendix B](#) for a list of recommended bump test gases.

Diagram 13-21. Alarm/Fault Simulation.

The screenshot shows a web browser window displaying the Honeywell Midas Gas Detector configuration page. The browser address bar shows the URL <http://159.254.60.47/>. The page header includes the Honeywell logo and the text "MDA Scientific Midas Gas Detector Midas Ver 2.12 build 5".

Name:	HA-M12340338		
Serial Number:	M12340338	Cartridge Serial Number:	12K50491
Location:	MIDAS Gas Detector		
IP Address:	169.254.60.47		

The main content area is titled "Alarm/Fault Simulation:" and contains a "Perform Test:" section with a red warning message: "CAUTION: Proceeding with Alarm or Fault Simulation may cause unexpected alarm activation. Only authorized operators should perform this task! MIDAS continues to monitor gas during simulation." Below this, there is a "Simulation:" section with radio buttons for "No Simulation" (selected), "Simulate Alarm 1", "Simulated Alarm 2", "Simulate Instrument Fault", and "Simulate Maintenance Fault". An "Accept" button is located at the bottom of the simulation options.

The left sidebar contains navigation menus for "Configuration" (General, Gas/Alarms, Faults, Network, Security, Time/Date), "Calibration" (Zero Calibration, Span Calibration, Flow Calibration, 4-20 mA Calibration), "Test" (Bump Test, Alarm/Fault Simulation, Inhibit, 4-20 mA Test), and "Authorized Users".

Via this web page an operator can test the alarm control philosophy by simulating a number of alarm or fault scenarios. Note that activating these simulations will drive any external alarm devices connected to the Midas® including the Modbus/TCP and the relay outputs. The simulation may be perceived as a false alarm/nuisance alarm if not fully communicated to other staff.

Diagram 13-22. Inhibit Mode.

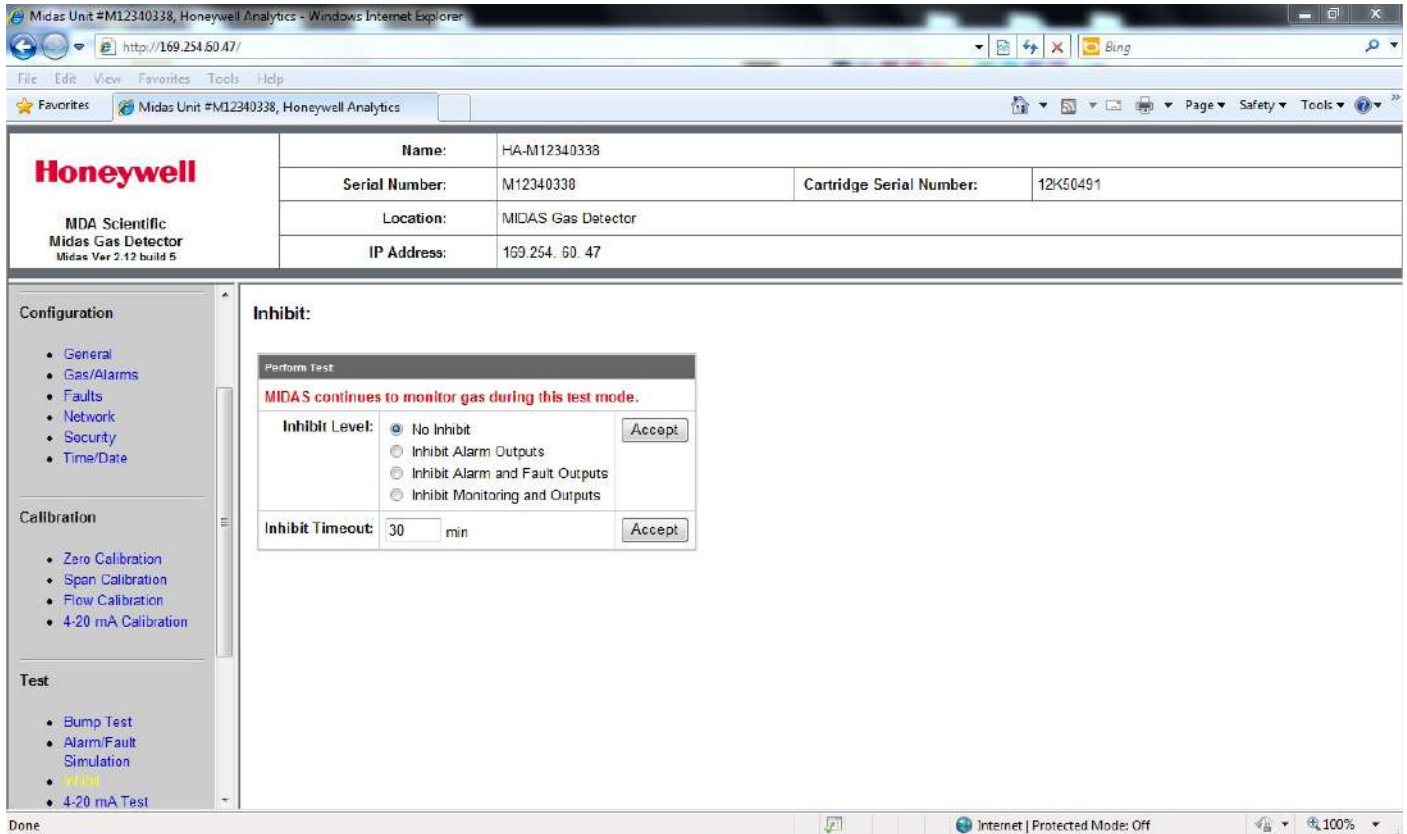

Inhibit mode temporarily disables the alarm or fault outputs from transmitting a signal during a test and configuration process so as to avoid nuisance or unexpected alarm scenarios. The Inhibit Timeout is the period of time (in minutes) that the Inhibit mode will stay active for until it will automatically default to No Inhibit mode.

Note

The Midas® can still monitor gas while in Inhibit Mode. Except in Inhibit Monitoring and Outputs.

Diagram 13-23. 4-20mA Test.

The screenshot shows a web browser window displaying the Honeywell Midas Gas Detector interface. The browser address bar shows the URL <http://169.254.60.47/>. The interface includes a header with the Honeywell logo and device information, a left sidebar with navigation options, and a main content area for the 4-20 mA Analog Output Test.

Honeywell MDA Scientific Midas Gas Detector Midas Ver 2.12 build 6	Name:	HA-M12340338	
	Serial Number:	M12340338	Cartridge Serial Number: 12K50491
	Location:	MIDAS Gas Detector	
	IP Address:	169.254.60.47	

4-20 mA Analog Output Test:

Status:
4.0 mA, Automatic Mode

Perform Test:
Proceeding with 4-20 mA test may cause unexpected alarm activation. Only authorized operators should perform this task!

Increase Cancel Decrease

Test

- Bump Test
- Alarm/Fault Simulation
- Inhibit
- 4-20 mA Test**

Authorized Users

- Diagnostics
- Service Menu
- Adv Pyrolyzer Diagnostics
- Adv Pyrolyzer Heater Test
- Adv Pyrolyzer Flow Test

This web page stimulates the analog 4-20 mA output to go to any desired current in 1 mA steps between 1 and 21 mA. This can be used to test the response of external equipment.

Honeywell

Midas® Gas Detector

Diagram 13-24. Authorized Users.

The screenshot shows a web browser window displaying the Honeywell Midas Gas Detector interface. The browser title is "Midas Unit #M12340338, Honeywell Analytics - Windows Internet Explorer" and the address bar shows "http://169.254.60.47/". The page features a navigation menu on the left with categories: "Test" (Zero Calibration, Span Calibration, Flow Calibration, 4-20 mA Calibration; Bump Test, Alarm/Fault Simulation, Inhibit, 4-20 mA Test) and "Authorized Users" (Diagnostics, Service Menu, Adv Pyrolyzer Diagnostics, Adv Pyrolyzer Heater Test, Adv Pyrolyzer Flow Test). The main content area displays the Honeywell logo and "MDA Scientific Midas Gas Detector Midas Ver 2.12 build 5". A table provides device details:

Name:	HA-M12340338		
Serial Number:	M12340338	Cartridge Serial Number:	12K50491
Location:	MIDAS Gas Detector		
IP Address:	169.254.60.47		

Below the table, a "Please input password." section contains a password field and an "Enter Service Menu" button. A "Forgot your password?" section contains a text input field and a "Get the Key" button. The browser status bar at the bottom indicates "Done", "Internet | Protected Mode: Off", and "100%" zoom.

The Diagnostics and Service menus are for specialist product support activities performed only by approved Honeywell Analytics service personnel and are not available to the end user.

Honeywell

Midas[®] Gas Detector

14 Typical Installation Topologies

14 Typical Installation Topologies

Midas® has very flexible installation options to allow the user to select the one most suitable for their specific application.

14.1 Conventional Installation

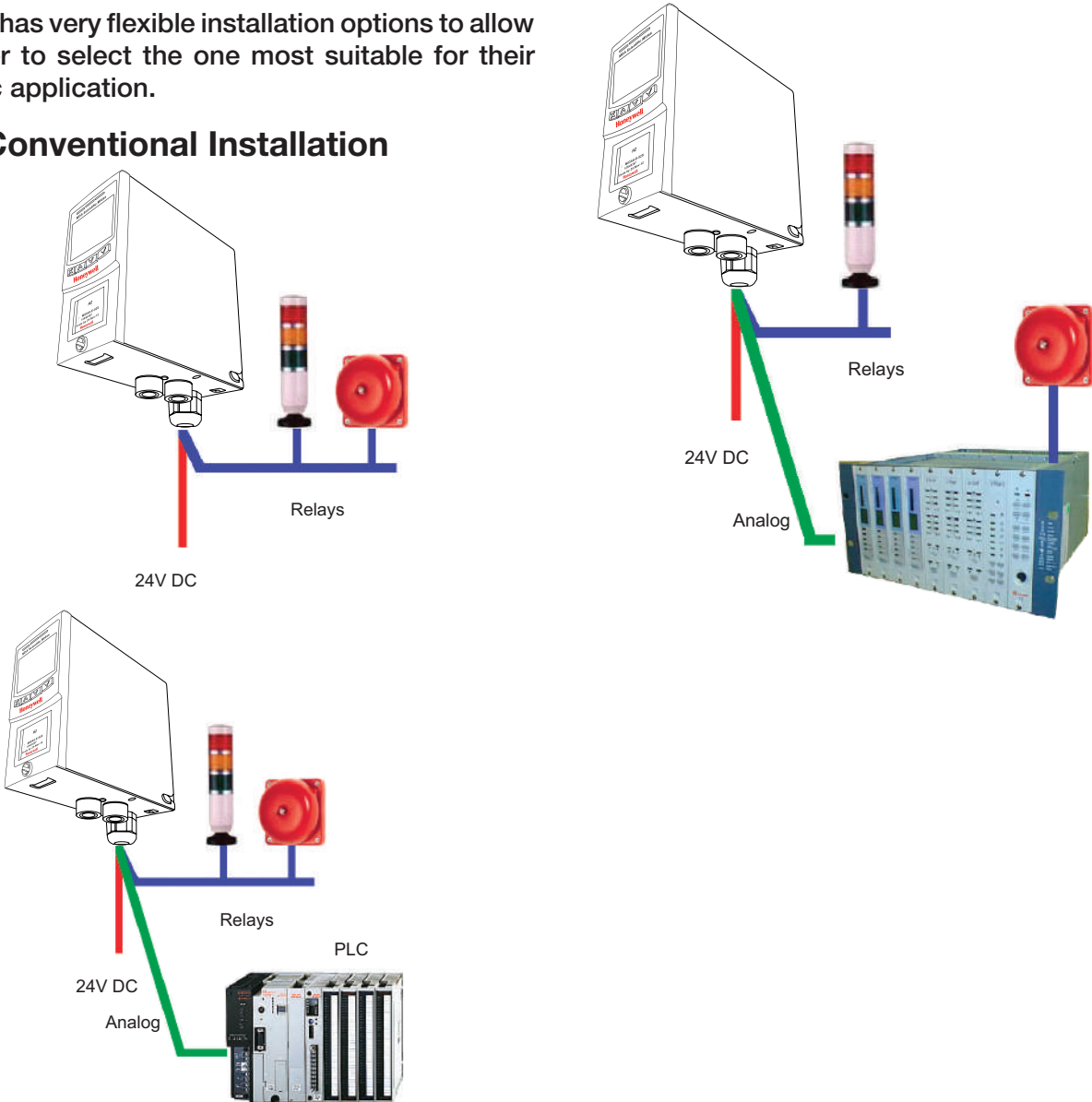

Honeywell

Midas® Gas Detector

14.2 Modbus/TCP Installation

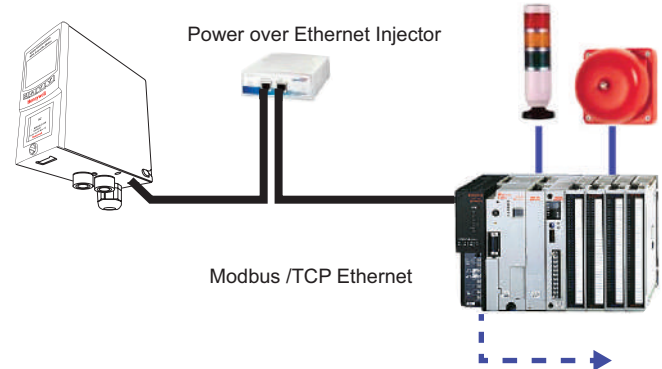
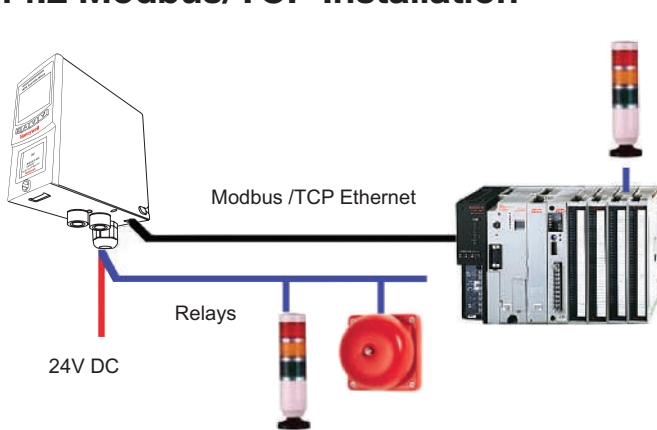

14.3 Power over Ethernet (PoE) Installation

Table 14-1. PoE Hub Power Budget

Mfr	Model	Ports		Total Power Budget (watts)	Max number of Midas Gas Detectors powered	
		PoE	Total		w/Pyro	w/o Pyro
3Com	3CNPSE-US	1	(injector)	15.4	1	1
NetGear	FS108P	4	8	32	1	3
D-Link	DES-1316	8	16	123	8	8
Allied Telesyn	AT-8524POE	24	24	370	24	24

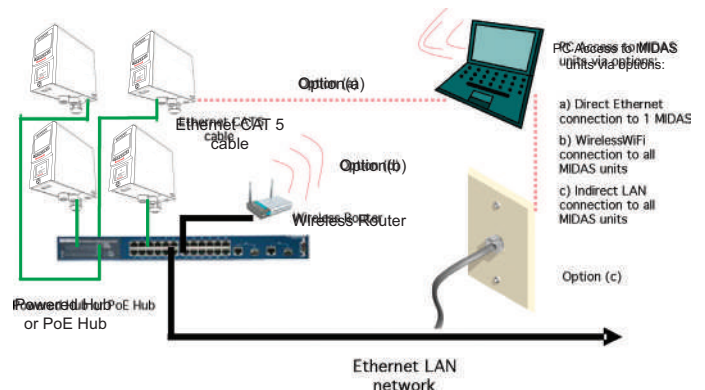
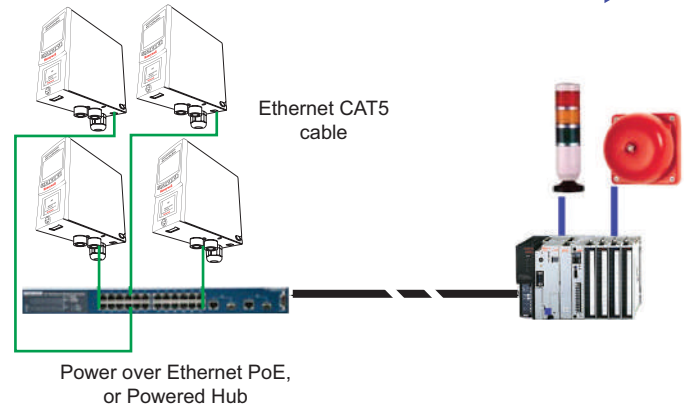

15 Ordering Information

15 Ordering information

This section contains details of how to order complete Midas® detector and sensor cartridge kits, separate transmitters and sensor cartridges as well as spares and accessories.

Item	Description	Part No.
Midas® Transmitter	Midas® transmitter. Complete with manual and quick start guide. (1) PG16 gland fitting for power in and relays out, 1/4" O.D. x 1/8" I.D. sample inlet tubing (10') [3m], 3/16" I.D. exhaust tubing (10') [3m], and a sample line tubing duct adapter. Order a sensor cartridge separately for each transmitter.	MIDAS-T-004
Midas® Pyrolyzer for NF₃	Midas® NF ₃ Pyrolyzer Module. Pyrolyzer in combination with Midas® transmitters provide detection of NF ₃ specifically. Unit includes a bolt-on pyrolyzer module that operates with and universal Midas® Extractive Transmitter (order separately) and (1) Freon in line filter. Units are powered via direct connection to transmitter unit. Consult Honeywell Analytics for additional gases that may become available via pyrolysis. Pyrolyzer includes Pyrolyzer Quick Start Guide and installation screws. Order the NF ₃ cartridge (MIDAS-S-HFX or MIDAS-E-HFX) separately. Order the ventilated top cover (MIDAS-A-039) separately.	MIDAS-T-00P
Midas® High-Temperature Pyrolyzer for Perfluoro Compounds	Midas® PFC (Perfluoro Compound) Pyrolyzer Module. PFC Pyrolyzer in combination with Midas® transmitters provide detection of various PFC compounds including C ₄ F ₆ , C ₅ F ₈ , CH ₂ F ₂ and CH ₃ F. Unit includes a bolt-on pyrolyzer module that operates with any Universal Midas® Extractive Transmitter (order separately). Units are powered via direct connection to transmitter unit. Consult Honeywell Analytics for additional gases detectable with this option. Pyrolyzer includes Pyrolyzer Quick Start Guide and installation screws. Order the PFC cartridge (MIDAS-S-CFX or MIDAS-E-CFX) separately. Order the ventilated top cover (MIDAS-A-039) separately.	MIDAS-T-HTP
Midas NP1 Pyrolyzer for NF3 and Perfluoro Compounds	Midas® NF3 and PFC Pyrolyzer Module. This Pyrolyzer in combination with Midas® transmitters provide detection of NF3 and various PFC compounds including C4F6, C5F8, CH2F2 and CH3F. Unit includes a bolt-on pyrolyzer module that operates with any Universal Midas® Extractive Transmitter (order separately). Units are powered via direct connection to transmitter unit. Consult Honeywell Analytics for additional gases detectable with this option. Pyrolyzer includes Pyrolyzer Quick Start Guide and installation screws. Order the sensor cartridge separately (MIDAS-S-XHF or MIDAS-E-XHF for NF3 and CH3F; MIDAS-S-XCF or MIDAS-E-XCF for C4F6, C5F8, and CH2F2).	MIDAS-T-NP1
Midas® LonWorks® Module	Midas® LonWorks® Interface Module. Option for use with connecting a Midas® transmitter or a transmitter with pyrolyzer, to a LonWorks® life safety communications network. Module provides all communication and power to the MIDAS® transmitter and transmits all gas readings, faults, alarms and other sensor diagnostics via the LonWorks® protocol. Access to LonMaker® version 3.1 configuration software is required (available separately).	MIDAS-T-LON

Honeywell

Midas® Gas Detector

15.5 Midas® Complete Gas Detector Kits

A complete kit including a universal Midas® transmitter (MIDAS-T-004) and a selected Midas® sensor cartridge can be ordered as a combined package. Each sensor cartridge is supplied with an extended 2 year warranty. Sensor cartridge and gas detector are packaged separately for ease of installation. Note that to detect NF_3 a separate pyrolyzer module must also be ordered.

Complete detector kit and sensor cartridge description	Kit part no.
Ammonia 0-100 ppm kit	MIDAS-K-NH3
Arsine 0-0.2 ppm and Germane 0-0.8 ppm kit	MIDAS-K-ASH
Boron Trichloride 0-8 ppm, Dichlorosilane 0-8 ppm, Hydrogen Bromide 0-8 ppm, Hydrogen Chloride 0-8 ppm	MIDAS-K-HCL
Boron Trifluoride 0-4 ppm, Hydrogen Fluoride 0-12 ppm, Nitrogen Trifluoride 0-40 ppm and Tungsten Hexafluoride 0-12 ppm kit	MIDAS-K-HFX
Bromine 0-0.4 ppm and Chlorine Dioxide 0-0.4 ppm kit	MIDAS-K-BR2
C4F6 0-40ppm, C5F8 0-40ppm and CH2F2 0-240ppm (A separate pyrolyzer module, MIDAS-T-0P3, must be ordered)	MIDAS-K-XCF
Chlorine 0-2 ppm and Fluorine 0-4 ppm kit	MIDAS-K-HAL
Carbon Dioxide 0-2.0% v/v kit	MIDAS-K-CO2
Carbon Monoxide 0-100 ppm kit	MIDAS-K-COX
Diborane 0-0.4 ppm kit	MIDAS-K-B2H
Hydrogen 0-1000 ppm kit	MIDAS-K-H2X
Hydrogen 0-100% LEL and Methane 0-100% LEL kit ¹	MIDAS-K-LEL
Hydrogen Cyanide 0-20 ppm kit	MIDAS-K-HCN
Hydrogen Sulfide 0-40 ppm kit	MIDAS-K-H2S
NF3 0-40ppm and CH3F 0-120ppm (A separate pyrolyzer module, MIDAS-T-0P3, must be ordered)	MIDAS-K-XHF
Nitric Oxide 0-100 ppm kit	MIDAS-K-NOX
Nitrogen Dioxide 0-12 ppm kit	MIDAS-K-NO2
Oxygen 0-25% v/v kit	MIDAS-K-O2X
Ozone 0-0.4 ppm kit	MIDAS-K-O3X
Phosphine 0-1.2 ppm kit	MIDAS-K-PH3
Silane 0-20 ppm and Disilane 0-20 ppm kit	MIDAS-K-SHX
Silane low level 0-2 ppm kit	MIDAS-K-SHL
Sulfur Dioxide 0-8 ppm kit	MIDAS-K-SO2
TEOS 0-40 ppm kit	MIDAS-K-TEO

¹ Midas® detectors are not ETL approved for monitoring in or sampling from classified areas above 25% LEL

Honeywell

Midas® Gas Detector



15.6 Accessories and Spares

Description	Part no.
Sample Line Tubing Duct Adapter	1283K1090
Replacement Pump Assembly for Midas® Gas Detector	MIDAS-A-007
Replacement Internal Air Filter for Midas® Gas Detector	MIDAS-A-009
Replacement RJ45 restraining strap	MIDAS-A-010
PoE Ethernet Injector	MIDAS-A-011
Freon/IPA Filter Extended Life (for NF ₃ pyrolyzing gas detector and IPA filter)	1830-0080
Freon/IPA Filter (for NF ₃ pyrolyzing gas detector and IPA filter)	1830-0027
Flexible Conduit 21" (0.53 m) - length	0235-0128
Flexible Conduit 27" (0.68 m) - length	0235-0163
Operating Instructions and Quick Start Guide for Midas® Gas Detector - English	MIDAS-A-001
End of line particulate filter	0780248
"L" Bracket for vertical mounting of one Midas® unit	MIDAS-A-032
DIN rail mounting kit for Midas® Transmitter or LonWorks® Interface Module	MIDAS-A-036
Ventilated top cover for pyrolyzer units	MIDAS-A-039
Black ventilated top cover for pyrolyzer units	MIDAS-A-103

16 Specifications

16 Specifications

Physical	
Size (unit with Sensor cartridge)	150 mm(H) x 65 mm(W) x 153 mm (D) (5.91 x 2.56 x 6.02 in)
Weight (unit with Sensor cartridge)	0.8 kg (1.76 lb)
NF₃ Pyrolyzer Dimensions	
Size	70 mm (H) x 63 mm (W) x 85 mm (D) (2.75 x 2.48 x 3.35 in)
Weight	0.41 kg (0.9 lb)
High-Temperature PFC Pyrolyzer Dimensions	
Size	100 mm (H) x 101 mm (W) x 140 mm (D) (3.9 x 4.0 x 5.5 in)
Weight	1.36 kg (3.0 lb)
OP3 Pyrolyzer Dimensions	
Size	132 mm (H) x 60 mm (W) x 98 mm (D)
Weight	1.20Kg (2.65 lb)
Power Requirements:	
Operating Voltage	24 V Nominal -15 to +10% (20.4 to 26.4 VDC) Midas® pyrolyzers and Midas® Transmitters with LonWorks Modules have a restricted minimum voltage requirement of 21.6 VDC.
Operating Voltage with Power over Ethernet	48 VDC Power-over-Ethernet (IEEE 802.3af compliant)
Power Consumption:	
Transmitter unit	< 5 W
Transmitter with pyrolyzer (std or hi temp)	< 12.95 W
Transmitter with LonWorks Module	< 8 W
Transmitter with LonWorks and pyrolyzer	< 15.95 W
Outputs:	
Visual	Alarm, power and fault LEDs plus LCD with all gas readings and events.
Relays	Alarm1, Alarm2, Fault Relays (3) rated 1.0 A @ 30VDC or 0.5 A @ 125 VAC max 10 uA @ 10 mV minimum, configurable as normally open or closed, latched or unlatched.
Analog	3 wire sink, 3 wire source, or 4 wire fully isolated; 0 to 21 mA.
Digital Communications	Modbus / TCP Ethernet / Power over Ethernet (PoE) / LonWorks® Interface Module
Service Port	RS232C / PPP protocol

Certification & Specification:	
European	 CE marked for sale in European community Meets EN 50270:2015 (type 2) / EN 61000-6-4: 2007 + A1:2011 /  IEC 60092-504:2001.  UKCA Marked for sale in the United Kingdom.
Environmental	ETL approved UL61010-1 Ed:3
Electrical	IEEE 802.3af-2003
Response Times:	
Typically	Refer to Individual Cartridge Datasheets
Transport System:	
Flow Rate	500 cc / min (10 in/H ₂ O maximum pressure/vacuum at inlet and exhaust points)
Transport Time	2 – 30 seconds maximum
Performance	LDL < LAL LAL = ½ TLV (typically 12% FSD) FSD = Typically 4 x TLV
Sampling Distance:	
Tubing Length	Up to 30 m (100 feet) with FEP tubing (refer to section B, Gas Tables)
Ambient Point	In line air filter required
Exhaust Length	Up to 30 m (100 feet)
Operating Temperature:	
Unit with sensor cartridge	0°C to 40°C (32°F to 104°F)
Unit with sensor cartridge and Pyrolyzer	0°C to 30°C (32°F to 86°F)
Tubing Requirement:	
Sample	6.35 mm OD (1/4") x 3.18 mm (1/8"), FEP, 30 m (100 feet) maximum dependent on gas type
Exhaust	6.35 mm (1/4") OD x 4.76 mm (3/16"), Polypropylene 30 m (100 feet) maximum
Wiring Requirement:	
4- 20mA	2 wire, 14 AWG maximum
Digital	CAT5 cable or equivalent; RJ45 connector
Gas Concentration Display & Interface:	
Instrument	4-digit alphanumeric display with separate units, flow rate bar graph and other icon driven indicators. 4 button interface keypad
Remote	Option for PC / PDA Internet browser access via Ethernet
Warranty:	
Transmitter Unit	1 year
Sensor cartridge	1 year standard, 2 years extended warranty
Expected Pyrolyzer Life (Standard and High-Temp)	1 year life, (12 month warranty)
Pump maintenance/swap interval	2 years minimum expected life (12 month warranty)
Mounting:	Wall mounted using pre-drilled holes on chassis. Options for DIN rail or vertical bracket mounting.
Case Material:	Cover: Painted steel Chassis/Mounting Bracket: Zinc plated steel

17 Calibration and Bump Testing

17 Calibration and Bump Testing

All Midas® sensor cartridges are pre-calibrated by Honeywell Analytics using traceable gas standards and approved calibration methods to a proven ISO 9000 quality controlled procedure. The Midas® sensor cartridge design is very robust and resistant to long term drift; in fact in a normal operating environment it is possible to extend the calibration interval with Midas® up to 24 months (subject to local requirements concerning calibrations). This design feature is another element that supports Midas® as a long term cost effective gas detection solution. Honeywell Analytics recommends frequent bump testing to confirm performance.

Note

It is the sole responsibility of each user to determine their own calibration and bump test schedule based on their own safety assessments and understanding of local requirements.

Just prior to commissioning, each Midas® unit should be zero calibrated to ensure accuracy. It is recommended that the unit be powered with the cartridge installed for at least 30 minutes prior to conducting a zero calibration. A second zero calibration may be required after a 24 hour period which is dependent on the site conditions. O₂ sensors are not zero calibrated but should be span gas calibrated. (See [Section 7.3.2](#) for span gas calibration details).”

If the ambient condition in the area the detector is monitoring experiences a long-term change, it is necessary to perform a zero calibration to allow the unit to adjust to the new conditions.

Note

When performing a zero calibration, be sure that the area is free of the target gas and/or interfering gases (refer to the cartridge data sheets for further details), as the presence of a background gas will affect the ability for the detector to properly calibrate to the correct levels. If the sample area cannot be verified to be free of the target gas or cross-sensitive gases, use a cylinder of zero air to perform the calibration

Calibration of an electrochemical sensor cartridge is a relatively complex discipline to master and it is possible that in less ideal field conditions the calibration can be far less accurate than under laboratory conditions and therefore substantial inaccuracies can be introduced. In the absence of any formal calibration policy by the end user, it is preferable to retain the original factory calibration.

Care must be taken to ensure that the correct materials for an extractive application are obtained from reputable suppliers and are of proven quality and composition. Inappropriate calibration equipment will lead to under- or over-presenting the wrong concentration of gas to the sensor cartridge during the calibration period. Likewise contaminated or inadequately flushed tubing and other gas-wet surfaces can also introduce errors into the calibration process. Only qualified, trained personnel should attempt to perform gas calibrations; contact your local Honeywell Analytics Service Representative for further details on calibration services.

Testing should be performed at the end of the sample tube or at the detector with a short length of tubing. Applying gas with a short length (less than 5 feet/1.5 meters) of clean FEP tubing will give optimal results for confirming the accuracy and response time of the cartridge.

Applying gas at the end of the installed sample line will test the full system including the whole length of tubing. This will verify the integrity of the tubing. Sample line integrity can also be checked by performing a leak check (see section 8.5). Note that there will be additional transport time due to the tubing length and conditioning the gas-wet surfaces (see table 4-1).

Bump tests are also used as an approximate means to present a controlled gas release to the sensor cartridge in order to verify that the transmitter does respond accordingly. Bump testing is popular as typical experiences show that a smaller list of easier to handle gases can be used to provide functional tests on a wider range of gas types. In the absence of a formal calibration policy from the end user, Honeywell Analytics would recommend a minimum semi-annual schedule of at least one bump test per sensor with the appropriate test gas (see details below).

Bump testing may reduce sensor cartridge lifetime and the accuracy of the calibration if applied incorrectly or too frequently. Use only the target gas or the recommended bump test gas.

Zero calibration is a recommended procedure that should be performed periodically to improve the performance of the sensor. This is particularly important when the sensor is operating outside of normal environmental conditions (20°C, 50% rH).

The tables in [Appendix B](#) indicate the recommended calibration or bump test gas for the Midas® sensor cartridges:

Consult with your Honeywell Analytics Service Representative for approved methods and materials before commencing calibrations and bump tests. See

Tech Note 1998-0219 *Protocol for Testing Toxic Gas Detectors* for additional information.

Bump the Testing Midas® Gas Detector

A bump test is not intended to be an accurate calibration, but is used as a confidence check to ensure that the gas detection system is functional. Since some of the target gases are difficult to handle, bump testing often makes use of cross sensitivities so that more convenient gases can be used. In bump test mode, the Modbus/TCP outputs are not inhibited. Only the 4-20 mA and alarm outputs are inhibited. The bump gas test is a functional check only. Consult local guidelines for recommended best practices. Bump test concentrations are calculated to generate a minimum first alarm level response.

Equipment

See Tech Note 1998-0219 *Protocol for Testing Toxic Gas Detectors* for additional information. These items are required:

- Test gas (see [Appendix B](#))
- Special regulator for extractive use (if using field calibration cylinder) or suitable sample bag (if not sampling directly from cylinder)
- Tubing (suitable for gas being applied)

Preparation

Most of the test gases are highly toxic. It is essential that personnel using these toxic gases be trained in their use. Ensure that the test gas will be vented safely.

Applying test gas may cause alarm, fault or

maintenance fault indications on the 4-20 mA loop, relays or digital outputs. Before starting a test, ensure that suitable steps have been taken to prevent these indications from triggering unwanted actions. The Midas® gas detector has a special mode for bump testing where the alarm outputs are inhibited (see [Section 7.4.1](#)).

See Tech Note 1998-0219 *Protocol for Testing Toxic Gas Detectors* for additional information. The NF_3 pyrolyzer should be tested in the same way as an extractive system, but using NF_3 as the test gas. If NF_3 is not available, chlorine can be used at a concentration of 5 ppm. If using chlorine, the Freon filter must be removed from the unit before the test and replaced after the test.

For the PFC High-Temperature pyrolyzer, chlorine can also be used as a suitable bump test gas.

Note

A test with chlorine operates the electrochemical cell and the unit's electronics, but does not test the pyrolyzer module itself.

Note

The electrochemical CO_2 cell (MIDAS-S/E-CO₂) is not designed for use in applications that are oxygen deficient (<15% O_2). Calibrations should always be carried out in CO_2 balanced with air.

Finishing

Wait for the gas reading to return to normal levels. This may take some time, especially if concentrations above the recommended levels have been used or if the test gas has been applied for an extended period of time.

Ensure that any latched faults or alarms that have been generated by the testing have been cleared.

Make sure that the gas detection system is fully restored to its normal operating state and that any control system overrides used during the testing have been removed.

The alarms generated by the testing will have created entries in the transmitter's history log.

Troubleshooting

If the test does not produce a satisfactory result, check the following points:

1. Check the gas cylinder concentration and type are correct
2. Check the expiration date of the cylinder.
3. Check that there is sufficient gas left in the cylinder.
4. Check that there are no leaks on the test system.
5. Make sure that the tubing length is as short as possible and that there are no blockages.
6. Make sure that the transmitter is not displaying a fault before the test is started.

A Modbus[®]/TCP Interface

A Modbus/TCP Interface

The Midas[®] gas detector can report concentration information in a variety of formats including relay contact closure, an analog 4-20 mA loop, Ethernet/IP/HTML web pages and via the Modbus/TCP networking protocol. This section defines the format of data in Modbus/TCP registers. More information about Modbus/TCP can be obtained from www.modbus.org. More information on the Midas[®] web pages is contained in [Section 14](#).

The Midas[®] is a Modbus/TCP “server” as defined in the MODBUS Application Protocol Specification V1.1a. It supports command 03 (“read holding registers”) for registers 40001 to 40018 as listed in Table 1.

This section describes Midas[®] software V1.08; previous software release levels support a subset of these registers.

The Midas[®] reports floating-point concentration numbers in little-endian or Intel format. This is scaled in units of ppm for gasses which have display units of ppm or ppb. For other display units the concentration is scaled directly in display units. This applies to registers FCN, A1T and A2T.

A.1 Reading Status from the Midas[®]

The Midas[®] fills 18 Modbus/TCP holding registers as listed in Table 1. The STTS register is a concise summary of Midas[®] status. The other registers provide more complete information.

Honeywell

Midas® Gas Detector

Table A1 – User-Readable Modbus Holding Registers

Ref. Addr. Reg. Name	Bits	Function	Value Enumeration
40001 STTS Status			
nibble 0	0-3	Monitoring state integer	
			0: Warmup
			1: Monitor mode with inhibit state “nonE”
			2: Monitor mode but alarms inhibited, inhibit state “ALm”
			3: Monitor mode but alarms and faults inhibited, inhibit state “AL-Ft”
			4: Monitor mode but fully Inhibited, inhibit state “ALL”
			5: Alarm / Fault Simulation
			6: Bump test mode (largely same as state 2)
			7: 4-20 mA loop Calibration mode
			8: Calibration Mode other than state 7
		9-15: for future expansion	
nibble1	4-5	Fault status integer	
			0: No fault
			1: Maintenance fault active
			2: Instrument fault active
	6		Alarm1 active
7		Alarm 2 active	
nibble2	8		Relay 1 energized
	9		Relay 2 energized
	10		Relay 3 energized
	11		Heartbeat Bit – toggles every two seconds to confirm communications
nibble3	12		Relays under remote Modbus/TCP control
	13-15	for future expansion	
40002 GASS Gas Selection			
	0-7	Gas ID	
	8-15	Sensor CartridgeID	
40003 FCN1 Gas Concentration in floating point format word 1 of 2			

Ref. Addr. Reg. Name	Bits	Function	Value Enumeration
40004 FCN2	Gas Concentration in floating point format word 2 of 2		
40005 CONC	Gas Concentration in Integer Format		
	Conversion equation: ppm value = Registry Value * 1/10 DECP		
40006 NOFT	Number of most important active fault		
40007 DPUN	Decimal point and units		
	0-2	Decimal point indicator (0-3)	
	3-7	for future expansion	
	8-15	Concentration units	
		1: ppm	
		2: ppb	
		4: % volume	
		8: %LEL	
		16: mA	
		0, 3, 5, 6, 7, 9-15, 17-255: for future expansion	
40008 TEMP	Temperature in Celsius		
	Signed 16-bit integer		
40009 CLRH	Cell life remaining in hours		
40010 HRTB	Heartbeat Counter, 16 LSB of time in seconds		
40011 FLOW	Sample flowrate in cc/minute		
40012	Reserved for future expansion, currently zero		
40013 A1T1	Alarm 1 threshold in floating point format, Scaling same as FCN1 and FCN2		
40014 A1T2			
40015 A2T1	Alarm 2 threshold in floating point format, Scaling same as FCN1 and FCN2		
40016 A2T2			
40017 ASI	Bits 0 – 1	Alarm status, equivalent to STTS bits 6-7	
	Bits 2-15	Zero	

Honeywell

Midas® Gas Detector

Ref. Addr. Reg. Name	Bits	Function	Value Enumeration					
40018 FSI	0	Maintenance fault active						
	1	Instrument fault active						
	2	Flow fault active						
	3	Internal communication fault active						
	4	Pyrolyzer fault active						
	5	Sensor fault active						
	6	Range over fault active						
	7-15	Reserved for future expansion						
40019 HST1	Concentration high scale in floating point format, scaling same as FCN1 and FCN2							
40020 HST2								
40071 DSN1	Detector serial number in ASCII code format, maximum 10 characters (2 characters per address) Example - for serial number ABCD12345, the address values are:							
40072 DSN2								
40073 DSN3								
40074 DSN4								
40075 DSN5								
			Address	40071	40072	40073	40074	40075
			Value	0x4142	0x4344	0x3132	0x3334	0x3500
40076 SSN1	Sensor serial number in ASCII code format, maximum 10 characters (2 characters per address) Example - for serial number ABCD12345, the address values are:							
40077 SSN2								
40078 SSN3								
40079 SSN4								
40080 SSN5								
			Address	40071	40072	40073	40074	40075
			Value	0x4142	0x4344	0x3132	0x3334	0x3500
40081 MSI	0	Warm-up (STTS nibble0 value = 0)						
	1	Monitor mode (STTS nibble0 value = 1, 2, 3, 4)						
	2	Test mode (STTS nibble0 value = 5, 6)						
	3	Maintenance mode (STTS nibble0 value = 7, 8)						
	4-15	Reserved for future expansion						

Honeywell

Midas® Gas Detector

A.2 Sending Commands to the Midas®

The Midas® can accept eleven commands over Modbus as listed in Table 3. It is possible to reset alarms, flip relays and perform similar tasks over the network. All commands are conveyed by writing 4 bytes to special registers as listed in table 2. This may be accomplished with command 06 (“write special register”) and command 16 (“write multiple registers”). For example, resetting alarms is accomplished by writing 350 to holding register 40021 and writing 13862 to holding register 40022.

The Midas® Modbus implementation avoids the standard “write coil” command in order to increase resistance to malicious communication over the Internet. Furthermore, Honeywell Analytics strongly recommends that any Midas® connected to the Internet be protected from unauthorized commands by a firewall.

The Modbus commands to manipulate the relays have no effect unless the relays are appropriately configured. This can be accomplished via the front “SEt/FLt” menu or by the Fault Configuration web page. By default, remote control is disabled.

Table A2. User-Writable Modbus Holding Registers

Ref. Addr. Reg. Name	Function
40021 CMD1	user command register 1
40022 CMD2	user command register 2
40013 A1T1	Alarm 1 threshold in floating point format, scaling same as FCN1 and FCN2
40014 A1T2	
40015 A2T1	Alarm 2 threshold in floating point format, scaling same as FCN1 and FCN2
40016A2T2	

Table A3. Effect of Writing to Modbus Holding Registers

CMD1 40021	CMD2 40022	Action
0x015E	0x3626	reset alarms and faults
0x025E	0x3626	Inhibit Alarms
0x035E	0x3626	Inhibit Alarms and Faults
0x045E	0x3626	Inhibit All
0x055E	0x3626	No Inhibit
0x065E	0x3626	Energize relay1
0x075E	0x3626	De-energize relay1
0x085E	0x3626	Energize relay2
0x095E	0x3626	De-energize relay2
0x0A5E	0x3626	Energize relay3
0x0B5E	0x3626	De-energize relay3
any other command		ignored

Honeywell

Midas® Gas Detector

A.3 Determining the MAC Address

Most Ethernet network administration is accomplished by configuring 32-bit internet protocol (IP) addresses. However, every Ethernet device also contains a media access controller (MAC) address. This low-level address is 48-bits long, fixed and unique.

With most computer equipment, knowledge of the MAC address is not necessary. The mapping between IP addresses and MAC addresses is handled transparently by the address resolution protocol or ARP. The Midas® and personal computers support ARP.

However, certain PLCs do not support ARP. This section explains how to determine the MAC address of a Midas® gas detector which is needed by these PLCs. This requires a computer with an Ethernet connection to the Midas®. This procedure uses Microsoft Windows XP, although Linux and other Microsoft operating systems will also work.

1. Establish Ethernet communications between the PC and the Midas®. Both must be on the same subnet.
2. Open a command prompt.
3. Execute the ping command as shown in Diagram A1.

Diagram A-1. Ping Command

```
C:\>ping 10.1.162.75

Pinging 10.1.162.75 with 32 bytes of data:

Reply from 10.1.162.75: bytes=32 time=2ms TTL=60
Reply from 10.1.162.75: bytes=32 time<1ms TTL=60
Reply from 10.1.162.75: bytes=32 time<1ms TTL=60
Reply from 10.1.162.75: bytes=32 time<1ms TTL=60
```

4. Execute the ARP command as shown in Diagram A2.

Diagram A-2. ARP Command

```
C:\>arp -a
Interface: 10.1.162.53 --- 0x2
Internet Address      Physical Address      Type
10.1.162.1            00-04-27-47-8b-0a    dynamic
10.1.162.75          00-40-9d-ba-d3-c3    dynamic
10.1.162.226         00-08-c7-45-07-d0    dynamic
```

5. Search for the IP address of the Midas® in the list. This has been highlighted in Diagram A2.
6. The MAC address is listed in the “Physical Address” column. So in this example the MAC address of the Midas® is 0x00409DBAD3C3.

ARP is defined by “request for comment” (RFC) 826. This document was written in 1982 and may be viewed at <http://rfc.sunsite.dk/rfc/rfc826.html>.

Honeywell

Midas[®] Gas Detector

B Gas Tables

B Gas Tables

Gas Name	Formula	Range	Lower Alarm Limit	Default Alarm 1	Default Alarm 2	Sensor Part Number	Maximum Sensor Warm-up Time (minutes)	Sensor Cartridge ID	Gas ID	Flow Rate (cc/min)	Calibration				Bump Test			Recommended Maximum Sample Line Length (m)	End of Line Filter
											Calibration Gas	Conc (ppm)	Output Equiv. (ppm)	Exp Time (sec)	Recommended Bump Test Gas	Conc (ppm)	Max Time (sec)		
Ammonia	NH ₃	0-100 ppm	12 ppm	12.5 ppm	25 ppm	MIDAS-S/E-NH3	10	01	1	500	NH ₃	50	50	300	NH ₃	50	180	10	780248, 1991-0147 or 1830-0055
Arsine	AsH ₃	0-200 ppb	5 ppb	5 ppb	10 ppb	MIDAS-S/E-ASH	20	02	1	500	AsH ₃	100 ppb	100 ppb	300	PH ₃	0.1	180	30	780248, 1991-0147 or 1830-0055
Boron Trichloride	BCl ₃	0-8 ppm	0.95 ppm	1 ppm	2 ppm	MIDAS-S/E-HCL	20	10	2, 6 ¹⁰	500	HCl	4	4	300	HCl	4-6	180	5 ⁴	1991-0147 or 1830-0055
Boron Trifluoride	BF ₃	0-8 ppm	0.96 ppm	1 ppm	2 ppm	MIDAS-S/E-HFX	20	08	2	500	HF	4	4.5	300	Cl ₂	5	180	5 ⁴	1991-0147 or 1830-0055
Boron Trifluoride Low Range	BF ₃	0-2 ppm	0.45 ppm	0.45 ppm	0.5 ppm	MIDAS-E-HFU	20	32	2	500	HF	1	1	300	Cl ₂	1	180	5	1991-0147 or 1830-0055
Boron Trifluoride Low Level	BF ₃	0-2 ppm	0.24 ppm	0.25 ppm	0.5 ppm	MIDAS-S/E-HFL	20	26	2	500	HF	1	1.12	300	Cl ₂	1	180	5 ⁴	1991-0147 or 1830-0055
Bromine	Br ₂	0-0.4 ppm	0.048 ppm	0.05 ppm	0.1 ppm	MIDAS-S/E-BR2	20	13	1	500	Cl ₂	0.2	0.2	300	Cl ₂	0.2	180	10	1991-0147 or 1830-0055
n-Butane	n-C ₄ H ₁₀	0-100% LEL	4.5% LEL	10% LEL	20% LEL	MIDAS-E-LEB	30	40	1	500	n-Butane	0.75 vol%	50%LEL	300	n-Butane	0.75 vol%	180	30	780248, 1991-0147 or 1830-0055
Carbon Dioxide	CO ₂	0-2 vol%	0.25 vol%	0.25 vol%	0.50 vol%	MIDAS-S/E-CO2	20	14	1	500	CO ₂	1 vol%	1 vol%	300	CO ₂	1 vol%	180	30	780248, 1991-0147 or 1830-0055
		0-2 vol%	0.25 vol%	0.25 vol%	0.50 vol%	MIDAS-I-CO2	10	92	1	500	CO ₂	1 vol%	1 vol%	300	CO ₂	1 vol%	180	30	780248, 1991-0147 or 1830-0055
		0-5 vol%	0.25 vol%	0.25 vol%	0.50 vol%	MIDAS-I-CO2	10	92	2	500	CO ₂	1 vol%	1 vol%	300	CO ₂	1 vol%	180	30	780248, 1991-0147 or 1830-0055
		0-0.2 vol%	0.02 vol%	0.02 vol%	0.05 vol%	MIDAS-I-CO2	10	92	3	500	CO ₂	0.1 vol%	0.1 vol%	300	CO ₂	0.1 vol%	180	30	780248, 1991-0147 or 1830-0055

Honeywell

Midas® Gas Detector

Gas Name	Formula	Range	Lower Alarm Limit	Default Alarm 1	Default Alarm 2	Sensor Part Number	Maximum Sensor Warm-up Time (minutes)	Sensor Cartridge ID	Gas ID	Flow Rate (cc/min)	Calibration				Bump Test			Recommended Maximum Sample Line Length (m)	End of Line Filter
											Calibration Gas	Conc (ppm)	Output Equiv. (ppm)	Exp Time (sec)	Recommended Bump Test Gas	Conc (ppm)	Max Time (sec)		
Carbon Monoxide	CO	0-100 ppm	12 ppm	12.5 ppm	25 ppm	MIDAS-S/E-COH	20	42	1	500	CO	50	50	300	CO	50	180	30	780248, 1991-0147 or 1830-0055
		0-100 ppm	12 ppm	12.5 ppm	25 ppm	MIDAS-S/E-COX	10	15	1	500	CO	50	50	300	CO	50	180	30	
Carbonyl Sulfide	COS	0-100 ppm	10 ppm	10 ppm	20 ppm	MIDAS-X-COS	60	44	1	500	COS	50	58	300	COS	50	180	30	780248 and 1830K0080
			25 ppm	25 ppm	50 ppm				2										
Chlorine	Cl ₂	0-2 ppm	0.24 ppm	0.25 ppm	0.50 ppm	MIDAS-S/E-HAL	10	12	1	500	Cl ₂	1	1	300	Cl ₂	1	180	10	1991-0147 or 1830-0055
		0-2 ppm	0.24 ppm	0.25 ppm	0.50 ppm	MIDAS-E-HAX	10	43	1	500	Cl ₂	1	1	300	Cl ₂	1	180	10	
Chlorine Dioxide	ClO ₂	0-0.4 ppm	0.048 ppm	0.05 ppm	0.1 ppm	MIDAS-S/E-BR2	20	13	2	500	Cl ₂	0.2	0.27	300	Cl ₂	0.2	180	10	1991-0147 or 1830-0055
Diborane	B ₂ H ₆	0-400 ppb	48 ppb	50 ppb	100 ppb	MIDAS-S/E-B2H	20 ³	33	1	500	B2H6	0.2	0.2	300	PH ₃	0.3	180	30	780248 2, 1991-0147 or 1830-0055
Dichlorosilane	SiH ₂ Cl ₂	0-8 ppm	0.95 ppm	1 ppm	2 ppm	MIDAS-S/E-HCL	20 ³	10	3, 7 ¹⁰	500	HCl	4	4	300	HCl	4-6	180	5 ⁴	1991-0147 or 1830-0055
Dichlorosilane High Range	H ₂ SiCl ₂	0-15 ppm	5 ppm	5 ppm	10 ppm	MIDAS-E-HCH	20	30	2	500	HCl	10	10	300	HCl	10	180	5	1991-0147 or 1830-0055"
Difluoromethane	CH ₂ F ₂	0-120 ppm	8 ppm	15 ppm	30 ppm	MIDAS-S/E-XCF	20 ³	35	3	500	HF ²	5	40	300	Cl ₂ ²	5	180	30	780248 ² , 1991-0147 or 1830-0055
Disilane	Si ₂ H ₆	0-20 ppm	2.4 ppm	2.5 ppm	5 ppm	MIDAS-S/E-SHX	20	05	2	500	SiH ₄	10	11.3	300	H ₂ S	50	180	10	780248, 1991-0147 or 1830-0055
Ethylene	C ₂ H ₄	0-100% LEL	4.5% LEL	10% LEL	20% LEL	MIDAS-S/H/E-LEL	30	25	5	500	H ₂	2 vol%	60 %LEL	300	H ₂	2 vol%	180	30	780248, 1991-0147 or 1830-0055
											C ₂ H ₄	1.35 vol%	50 %LEL	300	C ₂ H ₄	1.35 vol%	180	30	
Fluorine	F ₂	0-4 ppm	0.25 ppm	0.25 ppm	1.00 ppm	MIDAS-S/E-HAL	10	12	2	500	Cl ₂	2	2	300	Cl ₂	2	180	10	1991-0147 or 1830-0055
Germane	GeH ₄	0-800 ppb	95 ppb	100 ppb	200 ppb	MIDAS-S/E-ASH	20	02	2	500	AsH ₃	0.1	0.54	300	PH ₃	0.1	180	30	780248, 1991-0147 or 1830-0055

Honeywell

Midas® Gas Detector

Gas Name	Formula	Range	Lower Alarm Limit	Default Alarm 1	Default Alarm 2	Sensor Part Number	Maximum Sensor Warm-up Time (minutes)	Sensor Cartridge ID	Gas ID	Flow Rate (cc/min)	Calibration				Bump Test			Recommended Maximum Sample Line Length (m)	End of Line Filter
											Calibration Gas	Conc (ppm)	Output Equiv. (ppm)	Exp Time (sec)	Recommended Bump Test Gas	Conc (ppm)	Max Time (sec)		
Hexafluorobutadiene	C ₄ F ₆	0-40 ppm	4.0 ppm	5 ppm	10 ppm	MIDAS-S/E-XCF	20 ³	35	1	500	HF ²	5	10.38	300	Cl ₂ ²	5	180	30	780248 ² , 1991-0147 or 1830-0055
Hexafluorobutadiene (w/HTP pyro) High Range	C ₄ F ₆ **	0-80 ppm	20 ppm	20 ppm	40 ppm	MIDAS-E-CFH	20 ³	31	1	500	HF ²	10	43.41	300	Cl ₂ ²	10	180	30	780248 ² , 1991-0147 or 1830-0055
Hexafluoroisobutylene	C ₄ H ₂ F ₆	0-40 ppm	12 ppm	12 ppm	24 ppm	MIDAS-S/E-XCF	20 ³	35	5	500	HF ²	5	6.75	300	Cl ₂ ²	5	180	5	780248 ² , 1991-0147 or 1830-0055
Hydrogen (%LEL) ⁷	H ₂	0-100% LEL ¹	4.5% LEL	10% LEL	20% LEL	MIDAS-S/H/E-LEL ⁸	30	25	1, 3 ¹⁰	500	H ₂	2 vol%	50% LEL	300	H ₂	50% LEL	180	30	780248, 1991-0147 or 1830-0055
											CH ₄	2.5 vol%	44% LEL	300	CH ₄	50% LEL	180	30	780248, 1991-0147 or 1830-0055
Hydrogen (ppm)	H ₂	0-1000 ppm	120 ppm	125 ppm	250 ppm	MIDAS-S/E-H2X	10	16	1	500	H ₂	500	500	300	H ₂	500	180	30	780248, 1991-0147 or 1830-0055
Hydrogen Bromide	HBr	0-8 ppm	0.95 ppm	1 ppm	2 ppm	MIDAS-S/E-HCL	20	10	4, 8 ¹⁰	500	HCl	4	4.7	300	HCl	4-6	180	5 ⁴	780248, 1991-0147 or 1830-0055
Hydrogen Chloride	HCl	0-8 ppm	0.30 ppm	1 ppm	2 ppm	MIDAS-S/E-HCL	20	10	1, 5 ¹⁰	500	HCl	4	4	300	HCl	4-6	180	5 ⁴	1991-0147 or 1830-0055
Hydrogen Chloride High Range	HCl	0-15 ppm	1.7 ppm	5 ppm	10 ppm	MIDAS-E-HCH	20	30	1	500	HCl	10	10	300	HCl	10	180	5	1991-0147 or 1830-0055
Hydrogen Cyanide	HCN	0-20 ppm	2.4 ppm	2.5 ppm	4.7 ppm	MIDAS-S/E-HCN	10	17	1	500	HCN	10	10	300	SO ₂	4	180	10	780248, 1991-0147 or 1830-0055
Hydrogen Fluoride	HF	0-12 ppm	1.45 ppm	1.5 ppm	3 ppm	MIDAS-S/E-HFX	20	08	1	500	HF	5	5	300	Cl ₂	10	180	5 ⁴	1994-0147 or 1830-0055
Hydrogen Fluoride Low Range	HF	0 - 2 ppm	0.45 ppm	0.45 ppm	0.5 ppm	MIDAS-S/E-HFU	20	32	1	500	HF	1	1	300	Cl ₂	1	180	5	1991-0147 or 1830-0055
Hydrogen Fluoride Low Level	HF	0.18-2 ppm	0.24 ppm	0.25 ppm	0.5 ppm	MIDAS-S/E-HFL	20	26	1	500	HF	1	1	300	Cl ₂	1	180	5	1991-0147 or 1830-0055

(Note: Due to U.S. Government regulations, this range may be subject to restrictions requiring special licensing for certain countries outside North America. Contact Honeywell Analytics for eligibility information.)

Honeywell

Midas® Gas Detector

Gas Name	Formula	Range	Lower Alarm Limit	Default Alarm 1	Default Alarm 2	Sensor Part Number	Maximum Sensor Warm-up Time (minutes)	Sensor Cartridge ID	Gas ID	Flow Rate (cc/min)	Calibration				Bump Test			Recommended Maximum Sample Line Length (m)	End of Line Filter
											Calibration Gas	Conc (ppm)	Output Equiv. (ppm)	Exp Time (sec)	Recommended Bump Test Gas	Conc (ppm)	Max Time (sec)		
Hydrogen Sulfide	H ₂ S	0-40 ppm	4.8 ppm	5 ppm	10 ppm	MIDAS-S/E-H2S	10	18	1	500	H ₂ S	20	20	300	H ₂ S	20	180	30	780248, 1991-0147 or 1830-0055
Methane (%LEL) ⁷	CH ₄	0-100% LEL ¹	4.5%LEL	10% LEL	20% LEL	MIDAS-S/H/E-LEL ⁸	30	25	2, 4 ¹⁰	500	H ₂	2 vol%	57% LEL	300	H ₂	2 vol%	180	30	780248, 1991-0147 or 1830-0055
											CH ₄	2.5 vol%	50% LEL	300	CH ₄	2.5 vol%	180	30	780248, 1991-0147 or 1830-0055
Methyl Fluoride	CH ₃ F	0-120 ppm	10 ppm	15 ppm	30 ppm	MIDAS-S/E-XHF	20 ³	34	2	500	HF	5	52.50	300	Cl ₂	5	180	30	780248 ² , 1991-0147 or 1830-0055
Nitrogen Dioxide	NO ₂	0-12 ppm	1.45 ppm	1.5 ppm	3 ppm	MIDAS-S/E-NO2	10	20	1	500	NO ₂	6	6	300	NO ₂	50	180	30	1991-0147 or 1830-0055
Nitric Oxide	NO	0-100 ppm	12 ppm	12.5 ppm	25 ppm	MIDAS-S/E-NOX	10	19	1	500	NO	50	50	300	NO	50	180	30	780248, 1991-0147 or 1830-0055
Nitrogen Trifluoride	NF ₃	0-40 ppm	4.8 ppm	5.0 ppm	10.0 ppm	MIDAS-S/E-HFX	20	08	3	500	HF	5	5	300	Cl ₂	10	180	5 ⁴	1991-0147 or 1830-0055
		0-40 ppm	4.0 ppm	5 ppm	10 ppm	MIDAS-S/E-XHF	20 ³	34	1	500	HF ²	5	23	300	Cl ₂ ²	5	180	30	780248 ² , 1991-0147 or 1830-0055 1830- 0027 ⁶
Nitrous Oxide	N ₂ O	0-1000 ppm	125 ppm	250 ppm	500 ppm	MIDAS-I-N2O	10	93	1	500	N ₂ O	500	500	300	N ₂ O	500	180	30	780248, 1991-0147 or 1830-0055
n-Octane	n-C ₈ H ₁₈	0-100% LEL	4.5% LEL	10% LEL	20% LEL	MIDAS-E-LEO	30	41	1	500	n-Butane	0.75 vol%	50%LEL	300	n-Butane	0.75 vol%	180	30	780248 1991-0147 or 1830-0055

Gas Name	Formula	Range	Lower Alarm Limit	Default Alarm 1	Default Alarm 2	Sensor Part Number	Maximum Sensor Warm-up Time (minutes)	Sensor Cartridge ID	Gas ID	Flow Rate (cc/min)	Calibration				Bump Test			Recommended Maximum Sample Line Length (m)	End of Line Filter
											Calibration Gas	Conc (ppm)	Output Equiv. (ppm)	Exp Time (sec)	Recommended Bump Test Gas	Conc (ppm)	Max Time (sec)		
Octafluorocyclopentene	C ₅ F ₈	0-40 ppm	4.0 ppm	5 ppm	10 ppm	MIDAS-S/E-XCF	20 ³	35	2	500	HF ²	5	12.44	300	Cl ₂ ²	5	180	30	780248 ² , 1991-0147 or 1830-0055
Oxygen Proficiency & Deficiency	O ₂	0-25 vol%	5 vol%	23.5 vol%	19.5 vol%	MIDAS-S/E-O2X	30	21	1	500	O ₂	Air	21 vol%	300	O ₂	Air	180	30	780248, 1991-0147 or 1830-0055
						MIDAS-S/E-O2S	30	37	1	500	O ₂	Air	21 vol%	300	O ₂	Air	180	30	780248, 1991-0147 or 1830-0055
						MIDAS-L-O2S	30	38	1	500	O ₂	Air	21 vol%	300	O ₂	Air	180	30	780248, 1991-0147 or 1830-0055
Ozone	O ₃	0-0.4 ppm	0.048 ppm	0.05 ppm	0.1 ppm	MIDAS-S/E-O3X	20	22	1	500	O ₃	0.2	0.2	300	NO ₂ ⁹	1	180	5	1991-0147 or 1830-0055
Ozone High Level	O ₃	0-0.7 ppm	0.085 ppm	0.3 ppm	0.6 ppm	MIDAS-E-O3H	20	29	1	500	O ₃	0.5	0.5	300	NO ₂ ⁹	2	180	5	1991-0147 or 1830-0055
Phosphine	PH ₃	0-1200 ppb	145 ppb	150 ppb	300 ppb	MIDAS-S/E-PHX	20	36	1	500	PH ₃	0.6	0.6	300	PH ₃	0.6	180	30	780248, 1991-0147 or 1830-0055
Propane (%LEL) C ₃ H ₈ US	C ₃ H ₈	0-100% LEL	4.5% LEL	10% LEL	20% LEL	MIDAS-S/E-LEX	30	39	1	500	C ₃ H ₈	1 vol%	50% LEL	300	C ₃ H ₈	1 vol%	180	30	780248, 1991-0147 or 1830-0055
Propane (%LEL) C ₃ H ₈ EU		0-100% LEL	4.5% LEL	10% LEL	20% LEL	MIDAS-S/E-LEX			2	500	C ₃ H ₈	0.85 vol%	50% LEL	300	C ₃ H ₈	0.85 vol%	180	30	780248, 1991-0147 or 1830-0055
Propylene	C ₃ H ₆	0-100% LEL	4.5% LEL	10% LEL	20% LEL	MIDAS-S/H/E-LEL	30	25	6	500	H ₂	2 vol%	89 %LEL	300	H ₂	2 vol%	180	30	780248, 1991-0147 or 1830-0055
											C ₃ H ₆	1 vol%	50 %LEL	300	C ₃ H ₆	1 vol%	180	30	
R134a	C ₂ H ₂ F ₄	0-1000 ppm	50 ppm	250 ppm	500 ppm	MIDAS-S/E-XCF	20 ³	35	4	500	HF ²	5	225	300	Cl ₂ ²	5	180	5	780248 ² , 1991-0147 or 1830-0055

Honeywell

Midas® Gas Detector

Gas Name	Formula	Range	Lower Alarm Limit	Default Alarm 1	Default Alarm 2	Sensor Part Number	Maximum Sensor Warm-up Time (minutes)	Sensor Cartridge ID	Gas ID	Flow Rate (cc/min)	Calibration				Bump Test			Recommended Maximum Sample Line Length (m)	End of Line Filter
											Calibration Gas	Conc (ppm)	Output Equiv. (ppm)	Exp Time (sec)	Recommended Bump Test Gas	Conc (ppm)	Max Time (sec)		
Silane	SiH ₄	0-20 ppm	2.4 ppm	2.5 ppm	5 ppm	MIDAS-S/E-SHX	20	05	1	500	SiH ₄	10	10	300	H ₂ S	50	180	30	780248, 1991-0147 or 1830-0055
Silane Low Level	SiH ₄	0-2 ppm	0.24 ppm	0.25 ppm	0.50 ppm	MIDAS-S/E-SHL	20	06	1	500	SiH ₄	1	1	300	H ₂ S	3	180	30	780248, 1991-0147 or 1830-0055
Sulfur Dioxide	SO ₂	0-8 ppm	0.95 ppm	1 ppm	2 ppm	MIDAS-S/E-SO2	10	23	1	500	SO ₂	4	4	300	SO ₂	4	180	30	1991-0147 or 1830-0055
TEOS	TEOS	0-40 ppm	4.8 ppm	5 ppm	10 ppm	MIDAS-S/E-TEO	10	24	1	500	ETO	20	20	300	ETO	25	180	30	780248, 1991-0147 or 1830-0055
			5.8 ppm	6 ppm	10 ppm				2										
Tungsten Hexafluoride	WF ₆	0-12 ppm	1.45 ppm	1.5 ppm	3 ppm	MIDAS-S/E-HFX	20	08	4	500	HF	5	5	300	Cl ₂	10	180	5 ⁴	1991-0147 or 1830-0055
Tungsten Hexafluoride Low Range	WF ₆	0-2 ppm	0.45 ppm	0.45 ppm	0.5 ppm	MIDAS-E-HFU	20	32	3	500	HF	1	1	300	Cl ₂	1	180	5	1991-0147 or 1830-0055
Tungsten Hexafluoride Low Level	WF ₆	0-2 ppm	0.24 ppm	0.25 ppm	0.5 ppm	MIDAS-S/E-HFL	20	26	3	500	HF	1	1	300	Cl ₂	1	180	5 ⁴	1991-0147 or 1830-0055

General Notes:

¹ Midas® detectors are not ETL approved for monitoring in or sampling from classified areas above %25 LEL.

² End-of-line particulate filter (780248) MUST be removed when pyrolyzer unit is calibrated/bump tested with recommended gases other than target gases.

³ The pyrolyzer unit requires a longer warmup time and a humidifier must be added in the sample line when a dry calibration gas is applied to the detector directly from a target gas cylinder:

NF ₃	30 min
C ₄ F ₆	60 min
CH ₃ F	
CH ₂ F ₂	
C ₅ F ₈	
R134a	

⁴ Recommended to keep the sample lines as short as possible where the RH condition at the sample point is high (above %50 RH); there will be some sample loss due to absorption onto the sample line.

⁵ When calibrating or bump testing NF₃ sensor cartridges with Cl₂ or HF, the charcoal Freon filter (0027-1830) MUST be removed for calibration/bump testing then reinstalled for monitoring.

⁶ Freon filter 0027-1830 is required for this application.

⁷ The most common failure in catalytic sensors is performance degradation caused by exposure to certain poisons' (referred to as Catalytic Poisons). It is therefore essential that any catalytic based gas monitoring system should be checked regularly via bump tested (or re-calibrated), more importantly after any gas release notification when there is a potential poisoning based gases may be present. For further details contact Honeywell Analytics (please ensure all gases that are potentially present in the area of detection are available

prior to contacting)

⁸ MIDAS-E-LEL cartridge carries the standard 2 year warranty but can be calibrated to extend its life to 5 years. For the 2 year cartridges, Honeywell Analytics allows for a period of up to 6 months after the manufactured date for cartridge installation and then 2 years of use. If, for example, the cartridge is installed within the first 6 months, the expiration date will be 2 years after the installation date. If, however, the cartridge is installed more than 6 months after the manufactured date, it will expire 2.5 years after the manufactured date. Contact your local Honeywell Analytics Service Representative for more information.

⁹ An ozone generator can be used instead of 1 ppm NO₂.

¹⁰ Contact the local Honeywell Analytics service representative for more information.

Bump Testing Notes:

1. Use a concentration of 2 ppm.

IMPORTANT: this should only be done once to avoid the danger of poisoning the sensor.

2. The ambient Oxygen level is typically %20.9 by volume. If there is a serious problem with an Oxygen sensor, the reading will not be %20.9. The flow rate is regulated by the Midas® unit.

CO₂ test gases must be in a balance of air, not Nitrogen.

As an alternative, the actual target gas can always be used instead of a cross-sensitive gas.

Higher concentrations than the recommended ones can be used if necessary, but extra time may be needed for the reading to recover to zero.

IMPORTANT: Do not exceed the recommended concentrations or application times where Hydrogen Sulfide is used to test Silane. Doing this can damage the cell.

Honeywell

Midas[®] Gas Detector

C Warranty

C Warranty

All products are designed and manufactured to the latest internationally recognized standards by Honeywell Analytics under a Quality Management System that is certified to ISO 9001.

As such, the Midas® Transmitter (including the pump) is warranted under proper use, to the original end-user purchaser, against any defects in materials or workmanship related failures for a period of 12 months from the date of first turn-on or 18 months from delivery from Honeywell Analytics to the customer, whichever is less. Separate warranty conditions apply to the sensor cartridges limited as indicated below. During this period, Honeywell Analytics will repair or replace defective parts on an exchange basis, F.O.B. to approved service centers on a global basis.

This warranty does not cover damage caused by accident, abuse, abnormal operating conditions or extreme poisoning of the sensor cartridge.

Defective equipment must be returned to Honeywell Analytics for repair. Before returning materials for repair or replacement, the Customer must obtain a Service Event Number (SE#) by contacting Honeywell Analytics Service in advance; include a detailed report stating the nature of the defect and ship the equipment prepaid to Honeywell Analytics' factory. If no detail report is included, Honeywell Analytics reserves the right to charge an investigative fee (prices available upon request) before any repair or replacement is performed. Returned goods must detail the Service Event Number (SE#) clearly on the package.

Service in the field or at the customer's premises is not covered under these warranty terms. Time and travel expenses for on-site warranty services will be charged at Honeywell Analytics' normal billing rates.

Contact your Honeywell Analytics representative for information on available Service Contracts.

Honeywell Analytics shall not be liable for any loss or damage whatsoever or howsoever occasioned which may be a direct or indirect result of the use or operation of the Contract Goods by the Buyer or any Party.

This warranty covers the gas detector and parts sold to the Buyer only by authorized distributors, dealers and representatives as appointed by Honeywell Analytics. This warranty does not cover defects attributable to improper installation, repair by an unauthorized person or the use of unauthorized accessories/parts on the product. A warranty claim will only be accepted if a proof of purchase is submitted and all conditions obtained within this Warranty are met.

Honeywell Analytics reserves the right to validate any warranty claim prior to processing. Upon acceptance of a warranty claim, Honeywell Analytics will repair or replace the defective product free of charge. The initial warranty period is not extended by virtue of any works carried out there after.

Instruments which have been repaired or replaced during the warranty period are warranted for the remainder of the unexpired portion of the original warranty period. Honeywell Analytics is released from all obligations under its warranty in the event repairs or modifications are made by persons other than its own authorized personnel, unless such work is authorized in writing by Honeywell Analytics. The initial warranty period is not extended by virtue of any works carried out there under.

Honeywell Analytics reserves the right to change this policy at any time. Contact Honeywell Analytics for the most current warranty information.

Sensor Cartridge Warranty

Midas[®] sensor cartridges with part numbers beginning in MIDAS-S carry a 12 month (1 year) warranty from switch-on/installation or up to 18 months from the date of shipment from Honeywell Analytics, whichever is less, provided this takes place before the “Activate Before” date on the cartridge. Pro-rata after “Activate Before”/install by date.

Midas[®] sensor cartridges with part numbers beginning in MIDAS-E carry a 24 month (2 year) warranty from switch-on/installation or up to 30 months from the date of shipment from Honeywell Analytics, whichever is less, provided this takes place before the “Activate Before” date on the cartridge. Pro-rata after “Activate Before”/install by date.

1. The oxygen sensor cartridge is guaranteed to operate satisfactorily for the period described above and will be replaced at no charge within that period only if it will not provide a correct reading after calibration by Authorized Service personnel. Physical or chemical damage, resulting from exposure to improper elements, is not covered.
2. The combustible (LEL) sensor cartridge is guaranteed to operate satisfactorily for the period described above. If it will not provide a correct reading after calibration by Authorized Service personnel, it will be replaced at no charge within that period. This guarantee is void if it has been contaminated by some unusual substance, including but not limited to, water and/or other liquids, oily compounds, corrosives, silicones, lead vapors, extremely high concentrations of combustible gases, and various particulates which may inhibit gas flow to the sensor cartridge element.

3. The toxic sensor cartridges are guaranteed to operate satisfactorily for the period described above. They will be replaced at no charge within that period only if they will not provide a correct reading after calibration by Authorized Service personnel, and only if the sensor cartridge membranes exhibit no physical or chemical damage resulting from exposure to improper substances.

Note that the Midas[®] sensor cartridge stores an electronic history of each individual sensor cartridge's manufacture, warranty and calibration activity that is accessible by Authorized Service personnel.

Pyrolyzer Warranty

Pyrolyzer units, both Standard and High-Temperature, (MIDAS-T-00P and MIDAS-T-HTP, respectively) are warranted for a period of 12 months from initial turn-on or 18 months from delivery from Honeywell Analytics; whichever is less and are subject to the same terms and conditions outlined above. Model MIDAS-T-0P3 is warranted for 24 months from initial turn-on or 30 months from the date of delivery.

Find out more

www.honeywellanalytics.com

Americas

Honeywell Analytics
405 Barclay Boulevard
Lincolnshire, IL 60069
Tel: +1 847 955 8200
Toll free: +1 800 538 0363
Fax: +1 847 955 8208
detectgas@honeywell.com

Europe, Middle East, and Africa

Life Safety Distribution AG
Javastrasse 2
8604 Hegnau
Switzerland
Tel: +41 (0)44 943 4300
Fax: +41 (0)44 943 4398
gasdetection@honeywell.com

Asia Pacific

Honeywell Industrial Safety
7F SangAm IT Tower
434 Worldcup Buk-ro, Mapo-gu
Seoul 03922
Korea
Tel: +82 2 6909 0300
VOIP: +8 5401 0321
Fax: +82 2 6909 0329
analytics.ap@honeywell.com

Technical Services

ha.global.service@honeywell.com
www.honeywell.com

Honeywell

MIDAS-A-001
Revision 28
ECO 00210049
June 2021
©2021 Honeywell Analytics