

GARDENLINE®

2200W ELECTRIC CHAINSAW

User Guide



After Sales Support

Now you have purchased a Gardenline® product you can rest assured in the knowledge that as well as your 3 year parts and labour guarantee you have the added peace of mind of dedicated helplines and web support.

After Sales Support

Telephone: 1800 909 909
Internet: www.globalpowerbrands.com
help@globalpowerbrands.com

CONTENT

1. Introduction to the Operating Instructions	Page 2
1.1. Illustration and explanation of pictograms	
2. Important instructions for your personal safety	Page 2
2.1. General safety information for power tools	
1) Work area safety	
2) Electrical safety	
3) Personal safety	
4) Power tool use and care	
5) Service	
6) Emissions	
7) Chainsaw safety warnings:	
8) Causes and operator prevention of kickbacks:	
9) Important instructions for your personal safety	
a) General safety instructions	
b) Instructions on using the chainsaw safely	
c) Warning to the danger of recoil ("kickback")	
d) Instructions on safe working techniques	
3. Names of parts	Page 4
4. Starting up	Page 5
4.1. Filling the oil tank	
4.2. Assembling the blade and chain	
4.3. Connecting the chainsaw	
4.4. Switching on	
5. Safety devices on your chain brake	Page 6
5.1. Chain brake	
5.2. Rundown brake	
5.3. Safety starting lock	
5.4. Chain catch bolt	
6. Instructions on working properly with the chainsaw	Page 6
a) Felling a Tree	
b) Notching Undercut	
c) Felling Back Cut	
d) Limbing a Tree	
e) Bucking a Log	
7. Maintenance and Servicing	Page 8
8. In the case of technical problems	Page 8
• The machine does not start up	
• Chain does not run	
• Sparks fly at the motor	
• Oil does not flow	
9. Repair Service	Page 8
10. Waste disposal and environmental protection	Page 8
11. Spare parts	Page 8
12. Technical Data	Page 8
13. EC Declaration of Conformity	Page 9
14. Warranty	Page 9
15. Service	Page 9

1. Introduction to the Operating Instructions

These Operating Instructions are intended to facilitate your becoming acquainted with the machine and using it in accordance with the regulations. The Operating Instructions contain important information on how to use the machine safely, correctly and economically. Observing this information will help increase the reliability and working life of the machine. The Operating Instructions must always be at hand when the machine is being used.

They must be read and observed by every person dealing with the machine, whether operating, servicing or transporting it.

In addition to the Operating Instructions and the applicable rules of the prevention of accidents valid in the country of use and on site, the generally recognised rules on working safely and correctly must be observed as well as the accident prevention rules of the relevant professional associations.

1.1. Illustration and explanation of pictograms



Wear eye, head and ear protection !



Warning!



Read operation instructions before use



Do not subject this electric power tool to rain



Remove plug immediately if the power flex is damaged or cut



Attention, kick-back!



Hold tool with both hands!



Attention: Environmental Protection! This device may not be disposed of with general/household waste. Dispose of only at a designated collection point.

2. General safety instructions

Noise emission information in accordance with the German Equipment and Product Safety Act (GPSG) and the EC Machine Directive: the noise pressure level at the place of work can exceed 80 dB(A). In such cases the operator will require noise protection (e.g. wearing of ear protectors).

Attention: Noise protection ! Please observe the local regulations when operating your device.

2.1. General safety information for power tools



WARNING: Read all safety warnings and all instructions. Failure to follow the warnings and instructions may result in electric shock, fire and/or serious injury.

Save all warnings and instructions for future reference.

The term 'power tool' as used in the safety information and instructions includes both mains-operated tools (with power cord) and battery-operated tools (without power cord).

1) Work area safety

- a) **Keep work area clean and well lit.** Cluttered or dark areas invite accidents.
- b) **Do not operate power tools in explosive atmospheres, such as in the presence of flammable liquids, gases or dust.** Power tools create sparks which may ignite the dust or fumes.
- c) **Keep children and bystanders away while operating a power tool.** Distractions can cause you to lose control.

2) Electrical safety

- a) **Power tool plugs must match the outlet. Never modify the plug in any way. Do not use any adapter plugs with earthed (grounded) power tools.** Unmodified plugs and matching outlets will reduce risk of electric shock.
- b) **Avoid body contact with earthed or grounded surfaces, such as pipes, radiators, ranges and refrigerators.** There is an increased risk of electric shock if your body is earthed or grounded.
- c) **Do not expose power tools to rain or wet conditions.** Water entering a power tool will increase the risk of electric shock.
- d) **Do not abuse the cord. Never use the cord for carrying, pulling or unplugging the power tool. Keep cord away from heat, oil, sharp edges or moving parts.** Damaged or entangled cords increase the risk of electric shock.
- e) **When operating a power tool outdoors, use an extension cord suitable for outdoor use.** Use of a cord suitable for outdoor use reduces the risk of electric shock.
- f) **If operating a power tool in a damp location is unavoidable, use a residual current device (RCD) protected supply.** Use of an RCD reduces the risk of electric shock.

3) Personal safety

- a) **Stay alert, watch what you are doing and use common sense when operating a power tool. Do not use a power tool while you are tired or under the influence of drugs, alcohol or medication.** A moment of inattention while operating power tools may result in serious personal injury.
- b) **Use personal protective equipment. Always wear eye protection.** Protective equipment such as dust mask, non-skid safety shoes, hard hat, or hearing protection used for appropriate conditions will reduce personal injuries.
- c) **Prevent unintentional starting. Ensure the switch is in the off-position before connecting to power source and/or battery pack, picking up or carrying the tool.** Carrying power tools with your finger on the switch or energising power tools that have the switch on invites accidents.
- d) **Remove any adjusting key or wrench before turning the power tool on.** A wrench or a key left attached to a rotating part of the power tool may result in personal injury.
- e) **Do not overreach. Keep proper footing and balance at all times.** This enables better control of the power tool in unexpected situations.
- f) **Dress properly. Do not wear loose clothing or jewellery. Keep your hair, clothing and gloves away from moving parts.** Loose clothes, jewellery or long hair can be caught in moving parts.
- g) **If devices are provided for the connection of dust extraction and collection facilities, ensure these are connected and properly used.** Use of dust collection can reduce dust-related hazards.

4) Power tool use and care

- a) **Do not force the power tool. Use the correct power tool for your application.** The correct power tool will do the job better and safer at the rate for which it was designed.
- b) **Do not use the power tool if the switch does not turn it on and off.** Any power tool that cannot be controlled with the switch is dangerous and must be repaired.
- c) **Disconnect the plug from the power source and/or the battery pack from the power tool before making any adjustments, changing accessories, or storing power tools.** Such preventive safety measures reduce the risk of starting the power tool accidentally.
- d) **Store idle power tools out of the reach of children and do not allow persons unfamiliar with the power tool or these**

instructions to operate the power tool. Power tools are dangerous in the hands of untrained users.

- e) **Maintain power tools. Check for misalignment or binding of moving parts, breakage of parts and any other condition that may affect the power tool's operation. If damaged, have the power tool repaired before use.** Many accidents are caused by poorly maintained power tools.
- f) **Keep cutting tools sharp and clean.** Properly maintained cutting tools with sharp cutting edges are less likely to bind and are easier to control.
- g) **Use the power tool, accessories and tool bits etc. in accordance with these instructions, taking into account the working conditions and the work to be performed.** Use of the power tool for operations different from those intended could result in a hazardous situation.

5) Service

- a) **Have your power tool serviced by a qualified repair person using only identical replacement parts.** This will ensure that the safety of the power tool is maintained.

6) Emissions

- The specified vibration emission value was measured by a standardised test methods and can compare with other power tools are used.
- The specified vibration emission value can also be necessary for the assessment of work breaks are used.
- The specified vibration emission value can vary during the actual use of the electric tool by specifying the value, depending on the way how to use the power tool.
- **Note: You create the privilege against vascular pulsations of the hands in time breaks**

7) Chainsaw safety warnings:

- **Keep all parts of the body away from the saw chain when the chain saw is operating.** Before you start the chain saw, make sure the saw chain is not contacting anything. A moment of inattention while operating chain saws may cause entanglement of your clothing or body with the saw chain.
- **Always hold the chain saw with your right hand on the rear handle and your left hand on the front handle.** Holding the chain saw with a reversed hand configuration increases the risk of personal injury and should never be done.
- **Hold the electric equipment by its insulated handle surfaces, as the chainsaw can come into contact with its own mains power cable.** If the chainsaw comes into contact with a live cable, it can energise metal parts of the equipment and cause an electric shock.
- **Wear safety glasses and hearing protection. Further protective equipment for head, hands, legs and feet is recommended.** Adequate protective clothing will reduce personal injury by flying debris or accidental contact with the saw chain.
- **Do not operate a chain saw in a tree.** Operation of a chain saw while up in a tree may result in personal injury.
- **Always keep proper footing and operate the chain saw only when standing on fixed, secure and level surface.** Slippery or unstable surfaces such as ladders may cause a loss of balance or control of the chain saw.
- **When cutting a limb that is under tension be alert for spring back.** When the tension in the wood fibres is released the spring loaded limb may strike the operator and/or throw the chain saw out of control.
- **Use extreme caution when cutting brush and saplings.** The slender material may catch the saw chain and be whipped toward you or pull you off balance.
- **Carry the chain saw by the front handle with the chain saw switched off and away from your body. When transporting or storing the chain saw always fit the guide bar cover.** Proper handling of the chain saw will reduce the likelihood of accidental contact with the moving saw chain.
- **Follow instructions for lubricating, chain tensioning and changing accessories.** Improperly tensioned or lubricated chain may either break or increase the chance for kickback.
- **Keep handles dry, clean, and free from oil and grease.** Greasy, oily handles are slippery causing loss of control.

- **Cut wood only. Do not use chain saw for purposes not intended. For example: do not use chain saw for cutting plastic, masonry or non-wood building materials.** Use of the chain saw for operations different than intended could result in a hazardous situation.

8) Causes and operator prevention of kickback:

Kickback may occur when the nose or tip of the guide bar touches an object, or when the wood closes in and pinches the saw chain in the cut.

Tip contact in some cases may cause a sudden reverse reaction, kicking the guide bar up and back towards the operator.

Pinching the saw chain along the top of the guide bar may push the guide bar rapidly back towards the operator.

Either of these reactions may cause you to lose control of the saw which could result in serious personal injury. Do not rely exclusively upon the safety devices built into your saw. As a chain saw user, you should take several steps to keep your cutting jobs free from accident or injury.

Kickback is the result of tool misuse and/or incorrect operating procedures or conditions and can be avoided by taking proper precautions as given below:

- **Maintain a firm grip, with thumbs and fingers encircling the chain saw handles, with both hands on the saw and position your body and arm to allow you to resist kickback forces.** Kickback forces can be controlled by the operator, if proper precautions are taken. Do not let go of the chain saw.
- **Do not overreach and do not cut above shoulder height.** This helps prevent unintended tip contact and enables better control of the chain saw in unexpected situations.
- **Only use replacement bars and chains specified by the manufacturer.** Incorrect replacement bars and chains may cause chain breakage and/or kickback.
- **Follow the manufacturer's sharpening and maintenance instructions for the saw chain.** Decreasing the depth gauge height can lead to increased kickback.
- **Set the loop so that it is not detected during operation of branches or the like.**

9) Important instructions for your personal safety

a) General safety instructions

1. Children and young persons under 18 may not operate electrical chainsaws, with the exception of apprentices older than 16 under the supervision of a trained adult.
2. The chainsaw may only be used by persons who have sufficient experience.
3. Always keep these Operating Instructions together with the chainsaw.
4. Only lend or give this chainsaw to persons who are familiar with its use. Also give them these Operating Instructions.

B) Instructions on using the chainsaw safely

5. Attention! Read the Operating Instructions carefully and have yourself instructed in the use of a chainsaw before you use it for the first time.
6. Always store your electric tools in a safe place. Electric tools not being used should be stored in a dry, inaccessible or locked place, outside the reach of children.
7. Check the extension cable regularly and replace it if it gets worn or damaged.
8. Check the power cable for damage or cracks every time before you use it. Damaged cables must be replaced.
9. Always hold the chainsaw with both hands while working with it.
10. The chainsaw must be disconnected from the power supply before you tighten the chain, exchange the chain or carry out any other work on the saw. - Withdraw the plug!
11. During work breaks put the machine down in such a manner that nobody is at risk.
12. When switching on the chainsaw, ensure that it is supported well and hold it firmly. The chain and bar must be free.
13. Withdraw the plug immediately if the power cable is damaged or cut.
14. The chainsaw may only be connected to socket outlets with

earthing contact and tested electrical installations. We recommend the use of a residual-current-operated circuit-breaker. The fuse must have a value of 16 A and mustn't be used by other consumers while working with the chainsaw.

15. The cable must be wound off completely when you use a cable drum.
16. Ensure that the power cable has no kinks and is not damaged.
17. The chainsaw may only be used in a completely assembled state. No protective devices may be missing.
18. Switch the chainsaw off immediately if you notice any changes in the machine.
19. Always have a first-aid kit at hand in case of accidents.
20. If the chainsaw comes into contact with earth, stones, nails or other foreign objects, withdraw the plug immediately and check the chain as well as the bar.
21. Ensure that no chain oil penetrates into the earth or sewage. Always place the chainsaw on something that will absorb any oil dripping from the bar or chain.
22. Avoid to use the chainsaw in poor weather conditions, especially if there is a risk of a thunderstorm.

C) Warning to the danger of recoil ("kickback")

23. If possible, use a stand.
24. Always keep an eye on the bar tip.
25. Only place a running saw on the object to be cut. Never start the machine while the chain rests on something.
26. So called piercing cuts with the bar tip may only be carried out by trained personnel.

D) Instructions on safe working techniques

27. Working on ladders, scaffoldings or trees is forbidden.
28. Ensure that the wood cannot twist while it is being cut.
29. Watch out for splintering wood. While you are sawing you may be injured by flying wood chips.
30. Do not use the chainsaw to lever or move the wood.
31. Only cut with the lower section of the saw. The saw will be repulsed towards you if you try and cut with the upper section of the saw.
32. Ensure that the wood is free of stones, nails or other foreign objects.
33. We recommend that first-time users are instructed practically as to the correct use of the chainsaw and the required personal safety equipment by an experienced operator; the cutting of round wood or logs should be trained on a log stand or similar rack-type device first.
34. Keep the running chainsaw from touching the ground or wire fences.

3. Names of parts

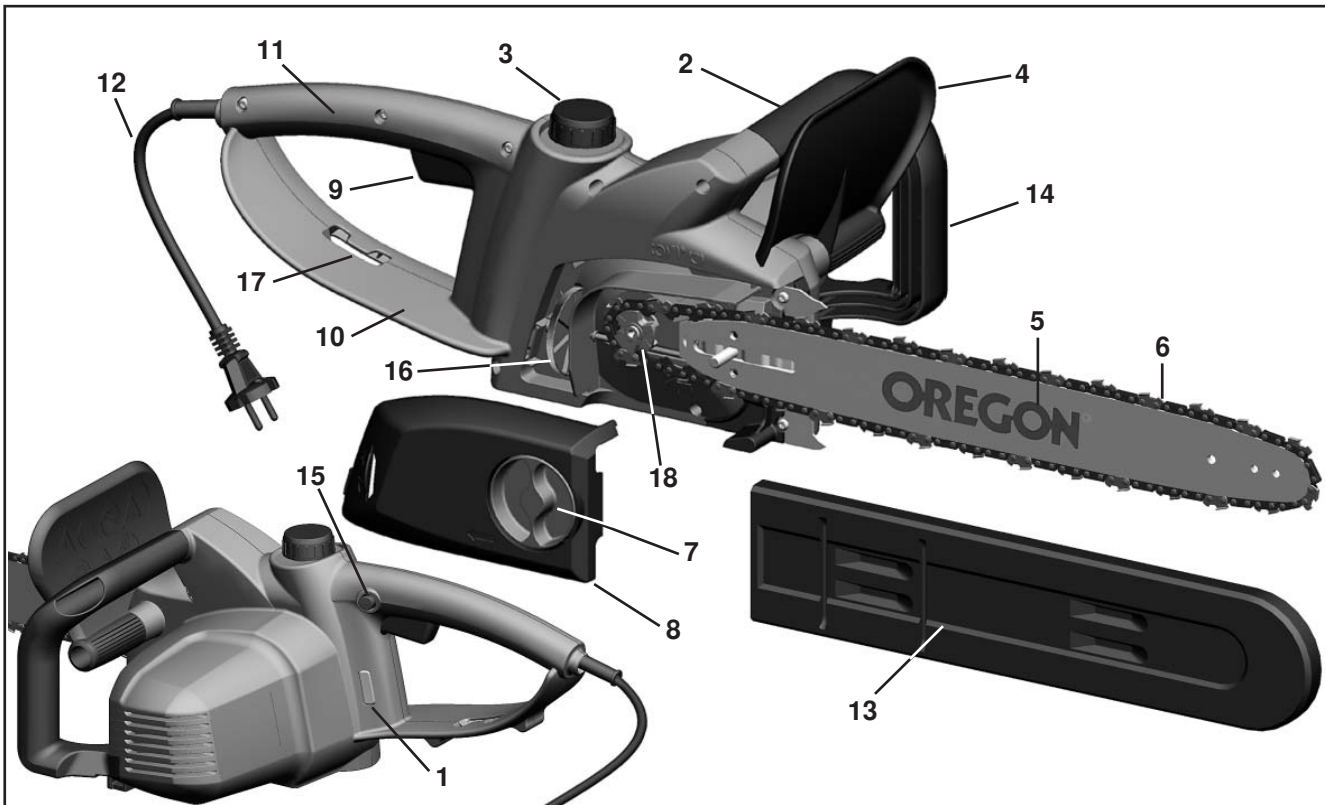

- | | | |
|--------------------------------------|-------------------------------|--|
| 1 Oil inspection window (see Fig. 2) | 7 T-screw | 13 Blade protection |
| 2 Front handle | 8 Pinion lid | 14 Fell handle for horizontal cut |
| 3 Oil tank cap | 9 Switch | 15 Stopping button (see Fig. 6 / 15) |
| 4 Front hand protection | 10 Rear hand protection | 16 Knurling wheel for quick chain tension adjustment |
| 5 Blade | 11 Rear handle | 17 Cable support |
| 6 Saw chain | 12 Mains connection with plug | 18 Chain drive wheel |

4. Starting up

4.1. Filling the oil tank



The chainsaw must never be operated without sufficient oil on the chain as this could cause damage to the chain, blade or motor. No claims for guarantee can be accepted if damage occurs when the device is being operated without chain oil.

Please use only biologically-based chainsaw oil, i.e. oil which is 100% biologically decomposable.

Biological chainsaw oil should be available everywhere at your local specialist dealer.

Do not use old oil. This will damage the chainsaw and will also lead to loss of the guarantee.

- Before filling the oil tank, pull out the mains plug
- Open the twist cap and place safely aside so that the sealing ring in the tank cap does not get lost.
- Fill approx. 200 ml oil into the tank using a funnel and screw on the tank cap tightly once more.

In order to allow you to operate your chainsaw immediately after purchasing, two (2) oil cans with 100 ml of oil each are enclosed. After the oil has been poured in the appropriate tank, the chainsaw is ready for use. Please do not forget to refill the oil tank as soon as possible.

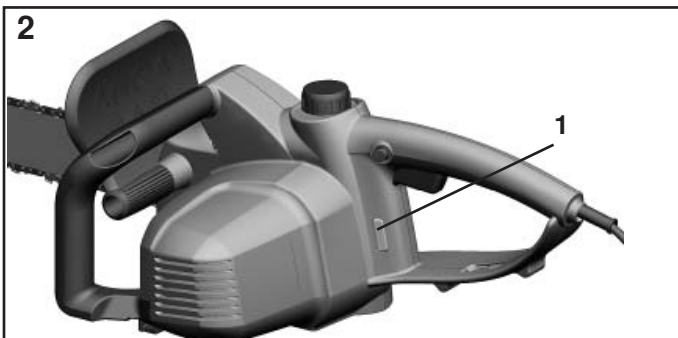

- The oil level can be seen in the inspection window (Fig. 2). If you plan not to use the machine for a longer period, you should remove the chain oil from the oil tank.
- The oil tank should also be emptied before the chainsaw is transported or sent for repair.
- Check correct functioning of the chainsaw before commencing work. Switch on the saw with cutting fittings assembled and hold over a bright background at a safe distance (Be careful not to come in contact with the ground !). A track of oil will show you that the chain is sufficiently lubricated.
- After use, lay the chainsaw horizontally on some absorbing surface. The oil spread on the blade, chain and drive may lead to some further dripping of oil.

4.2. Assembling the blade and chain

⚠ CAUTION ! Risk of injury ! Always use safety gloves when assembling the chain !

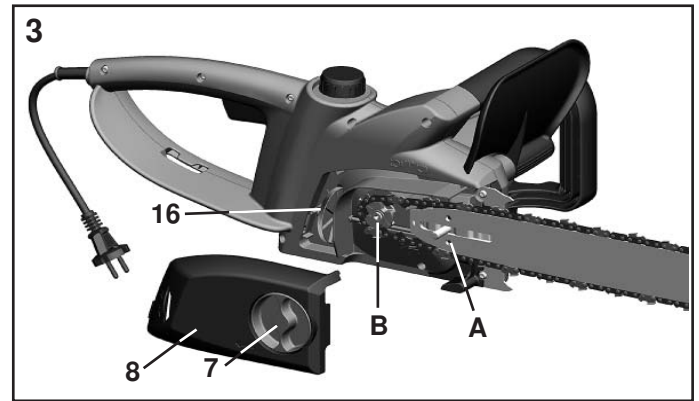

For assembling the bar and chain with this chainsaw no tools are required !

- Put the chainsaw on a stable rest.
- Loosen the T-screw 7 turning it clockwise.
- Remove the gear cover 8.
- Put the chain on the bar considering the running direction of the chain. **The cutting teeth on the upper side of the bar must point in forward direction** (see Fig. 4).
- Put the free end of the chain over the chain driving wheel (B).
- Place the bar such that the long hole in the bar is placed exactly on the guiding element in the bar seat.
- Take care that the chain tensioning bolt (A) is seated exactly in the small opening in the bar (Fig. 3). It must be visible through the opening. If necessary, adjust the knurling wheel of the chain tensioning device (16) in both directions until the chain tensioning bolt is seated in the opening in the bar.
- Check whether all chain links are seated exactly in the bar's groove and the chain is lead around the chain driving wheel correctly.
- Put the gear cover 8 back on and push it in place.
- Moderately tighten the T-screw 7 by turning it clockwise.

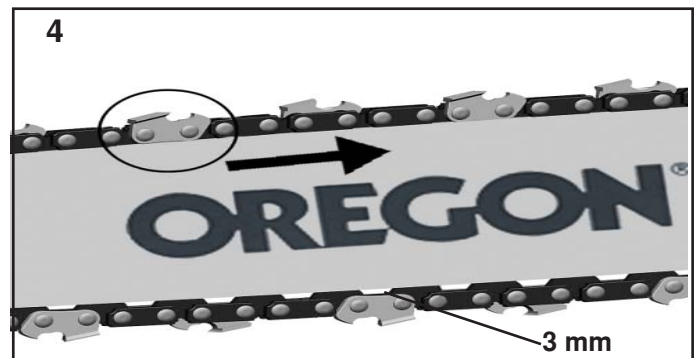

- Tension the chain. To do so turn the knurling wheel upwards (+ direction of arrow). The chain should be tensioned such that it can be lifted by about 3mm in the middle of the bar (Fig. 4). To decrease the chain tension turn the knurling wheel downwards (- direction of arrow).
- Finally, tighten the T-screw 7 well by hand.

The tension in the chain has a major effect on the service life of the cutting fittings, and must therefore be checked regularly. When the chain warms up to operating temperature it will expand and must be retightened. A new saw chain will have to be tightened more frequently until it has reached its full length.

⚠ CAUTION: During the running-in period, the chain must be more frequently tightened. The chain must be immediately retightened if it shakes or leaves the groove !

To tension the chain slightly loosen the T-screw 7. Then turn the knurling wheel upwards (+ direction of arrow). Tension the chain such that it can be lifted by about 3mm in the middle of the bar, as shown.

4.3. Connecting the chainsaw

We recommend to operate the chainsaw in connection with a residual current operated device with a maximum breaking current of 30mA.

This device is designed to be operated on a mains supply with a system

impedance Z_{max} at the point of connection (house service connection) of max. 0.4 Ohm. The user must ensure that the device is only operated on an electricity supply system meeting these requirements. If required, system impedance data may be obtained from the local public utility.

⚠ Use only extension cords that are approved for outdoor use and are not lighter than rubber-sheathed cables of type H07 RN-F according to DIN/VDE 0282 with a diameter of at least 1.5 sq. mm. They cords must be splash-proof. If the connection cable of this device should be damaged it must be replaced by a workshop named by the manufacturer only as this work requires the use of special tools. Mobile devices for outdoor use should be connected over a residual current operated device.

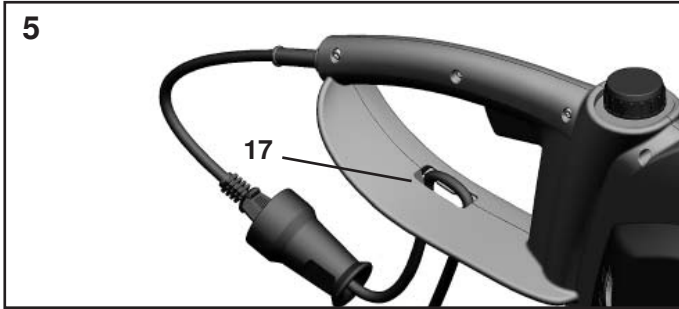

This chainsaw is fitted with a strain-relief device to provide extra safety for the connection. First connect the device plug with the connection line. Then form the connection line into a tight loop and push this through the safety web on the lower side of the machine. Hang the loop into the hook as shown in Fig. The plug connection is now secure against automatic release.

4.4. Switching on

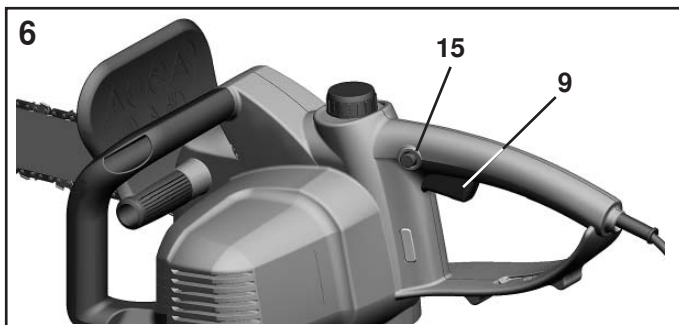

- Press with your thumbs the stopping button 15 on the left side of the rear handle and then the operating switch 9.
- The stopping button 15 is used for unlocking the switch-on mechanism and does not need to be pressed again after the device is switched on.
- To switch off the device, release switch 9.

⚠ Attention : The sawing chain will start running at high speed immediately. When putting the saw down, make sure that the chain never gets in touch with stones or metal objects.

5. Safety devices on your chain brake

5.1. Chain brake

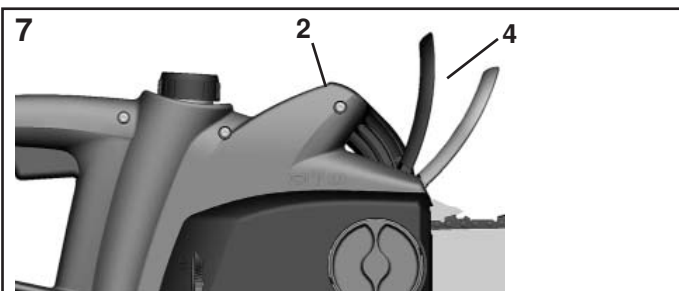

This chainsaw is equipped with a mechanical brake for the chain. In the case of uncontrolled movements, when the tip of the saw blade gets in contact with wood or a solid object, the drive of the chain is immediately

stopped by activation of the hand guard 4, the motor will not be stopped. This brake function is initiated by the back of your hand on the front handle 2 pushing the hand guard. The proper function of the saw chain brake shall be checked before each use of the saw. About every 10 hours of operation, the chain brake should be checked for its proper function. After the chain brake has been activated, wait for the motor to come to a halt before you engage the clutch again. Do not unnecessarily activate the chain brake as this may result in increased wear and tear.

⚠ CAUTION: No buttons should be pressed when the chain brake is released (hand protection pulled back in the direction of the handle and locked).

Always ensure before starting the chainsaw that the hand protection 4 is locked in the operating position. To do this, pull back the hand protection in the direction of the handle.

5.2. Rundown brake

In accordance with the latest regulations, this chainsaw is equipped with a mechanical rundown brake. This brake is connected to the chain brake and stops the running chain after the chainsaw has been switched off. It is activated by releasing the ON/OFF switch. The rundown brake avoids injuries through the coasting of the chain.

5.3. Safety starting lock

The starting delay that is effective for about 3 sec. after each switch-off of the chainsaw provides for additional safety.

Thus, for your own safety, there is a delay of 3 seconds before the device can be switched on again after each time it is switched off.

Only after this phase, the saw may be operated again by pushing the locking button 15 and subsequently activating the operating switch 9, as described in the section 'Switching on'.

5.4. Chain catch bolt

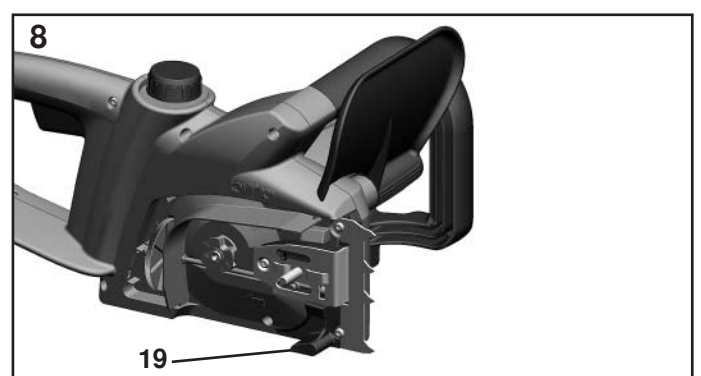

This chainsaw is fitted with a chain catch bolt (19). If the chain breaks when the saw is in operation, the chain bolt will catch the loose chain end and thus prevent injury to the operator's hand.

6. Instructions on working properly with the chainsaw

a) Felling a Tree

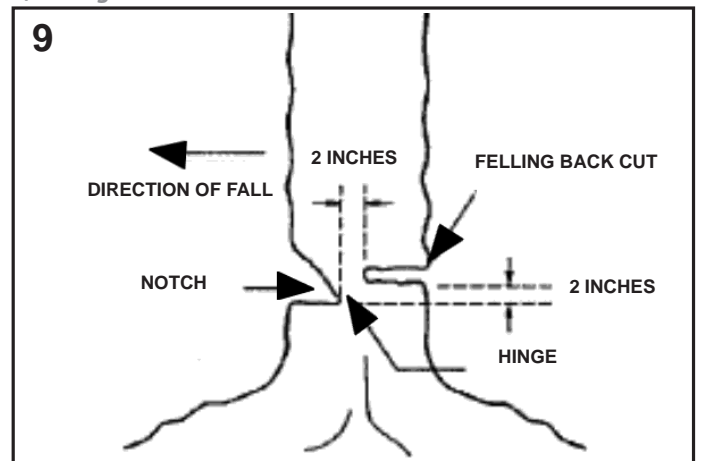

When bucking and felling operations are being performed by two or

more persons, at the same time, the felling operation should be separated from the bucking operation by a distance of at least twice the height of the tree being felled. Trees should be felled in a manner that would endanger any person, strike any utility line, the utility company should be notified immediately.

The chainsaw operator should keep on the uphill side of the terrain as the tree is likely to roll or slide downhill after it is felled.

A retreat path should be planned and cleared as necessary before cuts are started. The retreat path should extend back and diagonally to the rear of the expected line of fall as illustrated in Figure 10.

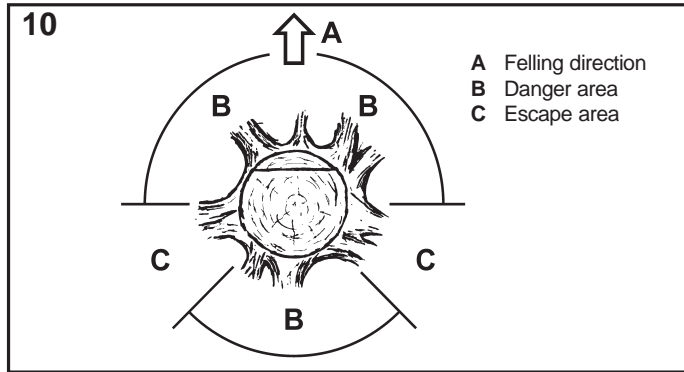

Before felling is started, consider the natural lean of the tree, the location of larger branches and the wind direction to judge which way the tree will fall. Remove dirt, stones, loose bark, nails, staples, and wire from the tree where felling cuts are to be made.

b) Notching Undercut

Make the notch 1/3 the diameter of the tree, perpendicular to the direction of fall as illustrated in 9. Make the lower horizontal notching cut first. This will help to avoid pinching of either the saw chain or the guide bar when the second notch is being made.

c) Felling Back Cut

Make the felling back cut at least 2 inches (50.8 mm) higher than the horizontal notching cut as illustrated in Figure 9. Keep the felling back cut parallel to the horizontal notching cut. Make the felling back cut so enough wood is left to act as a hinge. The hinge wood keeps the tree from twisting and falling in the wrong direction. Do not cut through the hinge.

As the felling cut gets close to the hinge the tree should begin to fall. If there is any chance that the tree may not fall in the desired direction or it may rock back and bind the saw chain, stop cutting before the felling back cut is complete and use wedges of wood, plastic or aluminum to open the cut and drop the tree along the desired line of fall. When the tree begins to fall remove the chainsaw from the cut, stop the motor, put the chainsaw down, then use the retreat path planned. Be alert for overhead limbs falling and watch your footing.

d) Limbing a Tree

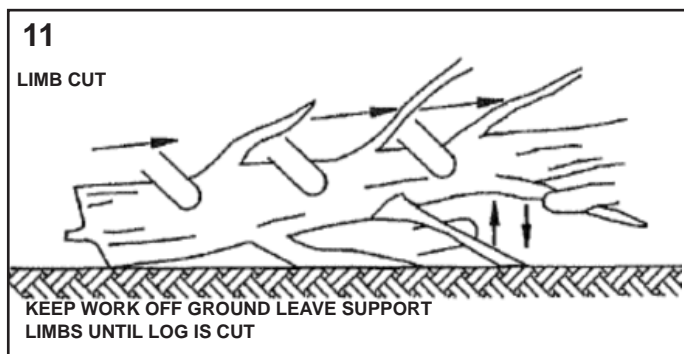

Limbing is removing the branches from a fallen tree. When limbing, leave larger lower limbs to support the log off the ground. Remove the small limbs in one cut as illustrated in Figure 11. Branches under tension should be cut from the bottom up to avoid binding the chainsaw.

e) Bucking a Log

Bucking is cutting a log into lengths. It is important to make sure your footing is firm and your weight is evenly distributed on both feet. When possible, the log should be raised and supported by the use of limbs, logs or chocks. Follow the simple directions for easy cutting.

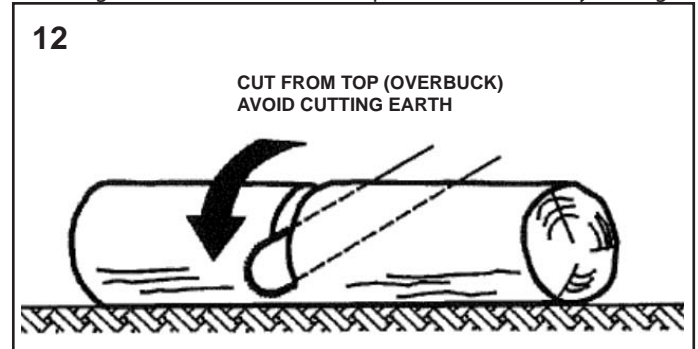

When the log is supported along its entire length as illustrated in Figure 12, it is cut from the top (over-buck).

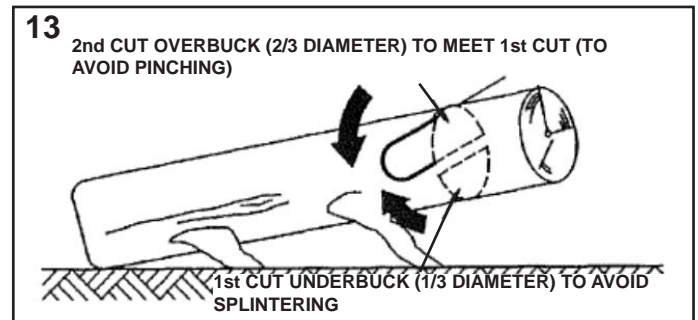

When the log is supported on one end, as illustrated in Figure 13, cut 1/3 the diameter from the underside (underbuck). Then make the finished cut by overbucking to meet the first cut.

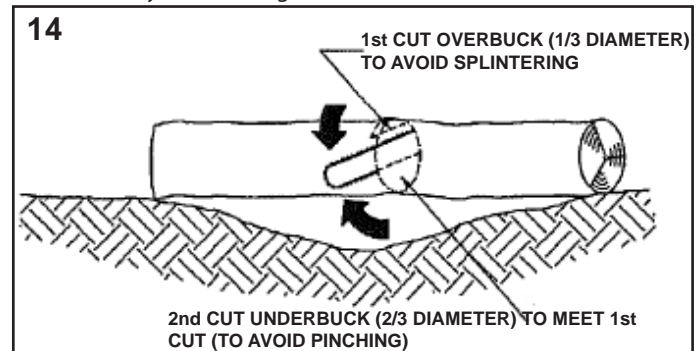

When the log is supported on both ends, as illustrated in Figure 14, cut 1/3 of that diameter from the top overbuck. Then make the finished cut by underbucking to meet the first cut.

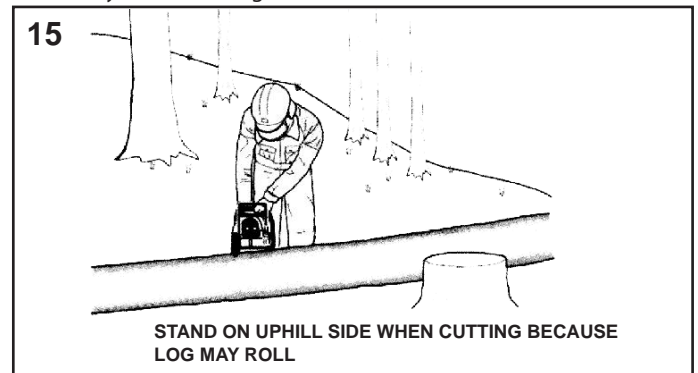

When bucking on a slope always stand on the uphill side of the log, as illustrated in Figure 15. When "cutting through", to maintain complete control release the cutting pressure near the end of the cut without relaxing your grip on the chainsaw handles. Don't let the chain contact the ground. After completing the cut, wait for the saw chain

to stop before you move the chainsaw. Always stop the motor before moving from tree to tree.

7. Maintenance and Servicing

Always withdraw the plug when carrying out maintenance and servicing.

- Clean the tool's housing with a moistened cloth; in case of heavier soiling you may use a bit of a mild dishwashing liquid. Do never spray or splash the tool with water!
- Always remove wood shavings and oil from your chainsaw after use. Ensure in particular that the motor ventilation slits for cooling the motor in the housing of the chainsaw is free (danger of overheating).
- If the saw chain is particularly dirty, e.g. in case of gumming with resin, remove the chain and clean it. Place the chain for a few hours in a vessel containing chainsaw cleaner. There-after clean the chain with clear water. If the chain is not used again immediately, it must be treated with service spray or a customary anticorrosion-spray.
- Only in case of use of biological oil: As some biological oils may tend to incrustation after a time, the oiling system should be rinsed thoroughly before storing the chainsaw for a longer period. Therefore, please fill half of the oil reservoir (about 50 ml) with chainsaw cleaner and close it as usually. Then switch on the chainsaw - without bar and chain being mounted - and keep it running until the total rinsing liquid has evaporated through the oil opening of the chainsaw. Before using the chainsaw again, it is absolutely necessary to refill the oil reservoir.
- Do not store the saw outdoors or in damp and moist areas.
- Check all the chainsaw parts, in particular the chain, bar and sprocket, of wear after every use.
- Ensure that the chain tension is correct. If the chain is too loose, it may come off during use and lead to injuries. The chain must be replaced immediately if it is damaged. The cutting teeth must be at least 4 mm long.
- Check the motor housing and power cable after every use for damage. If there is any sign of damage, have the chainsaw checked by a specialised workshop or the works after-sales service.
- Check the oil level and lubrication of your chainsaw after every use. Insufficient lubrication leads to damage to the chain, bar and motor.
- Check how keen the chain is every time before you use the chainsaw. A blunt chain will cause overheating of the motor.
- Sharpening a saw chain requires experience and specialised knowledge. We therefore recommend to have sharpening carried out by a specialised workshop.

8. In the case of technical problems

- **The machine does not start up:** Check whether the current socket is live. Check whether the power cable is undamaged. If neither case applies, take the chainsaw to a specialised workshop or the works after-sales service.
- **Chain does not run:** Check position of handguard (see ill. 7). Chain only runs if handguard brake is released.
- **Chain does not cut at all :** Chain is not mounted to the correct direction. Assemble the chain to the correct direction.
- **Sparks fly at the motor:** Motor or carbon brushes damaged. Take the chainsaw to a specialised work-shop or the works after-sales service.
- **Oil does not flow:** Check the oil level. Clean the oil flow openings in the bar (see also the corresponding hints of "Maintenance and servicing). If this is not successful, take the chainsaw to a specialised work-shop or the works after-sales service.

 **Attention: Any maintenance or repair work going beyond that described in these Operating Instructions may only be carried out by authorised persons or the works after-sales service.**

 **Attention: If the power supply lead of this device shows any defects, the lead must be replaced by an authorized repair shop only or through the manufacturer's own service personnel, as this work requires special tools**

9. Repair Service

Repairs to electric power tools should only be carried out by specialist electrical personnel.

Always keep the original packaging for a possibly required shipping of the tool.

10. Waste disposal and environmental protection

If your chainsaw should become useless somewhere in the future or you do not need it any longer, do not dispose of the device together with your domestic refuse, but dispose of it in an environmentally friendly manner. Please dispose of the device itself at an according collecting/recycling point.

By doing so, plastic and metal parts can be separated and recycled. Information concerning the disposal of materials and devices are available from your local administration.

Properly dispose of packaging material that is not required any longer via your local waste paper disposal system.

11. Spare parts:

Bar (400 mm)	Art.-Nr. 30111064
Chain (400 mm)	Art.-Nr. 30019560

12. Technical Data

This chainsaw has been built in accordance with Regulation DIN EN 60745-2-13 and fulfils the requirements of the European law on equipment safety.

Model	Gardenline	KSI 2200
Rated Voltage	V~	240
Nominal Frequency	Hz	50
50Fuse (time lag)	A	16
Rated Output	W	2200
Nominal current	A	10
Guide Bar	mm	400
Cutting length	mm	380
Speed	m/sec	ca. 10
Weight	kg	5,0
Oil	ml	200

All models with automatic chain lubrication and mechanical chain brake and rundown brake.

The type designation of the chain you will find on the type plate.

Class of Protection: II/ DIN-EN 60745-1

Interference Suppression: according to EN 55014

Noise emission information in accordance with the German Equipment and Product Safety Act (GPSG) and the EC Machine Directive:

Noise emission values EN-60745:

Acoustic capacity level LWA 101,7 KWA = 3,0 dB(A)

Sound Pressure Level LpA 90 dB (A) K=3,0 dB (A)

Vibration values in accordance with EN 60745:

Weighted acceleration handle max. 6,1 m/s² K=1,5 m/s²



Attention: This chainsaw is only intended for cutting wood !!!

13. EC Declaration of Conformity

We, **MOGATEC Moderne Gartentechnik GmbH, Im Grund 14, 09430 Drebach**, declare under our sole responsibility that the product **ELECTRIC CHAINSAW Gardenline KSI 2200**, to which this declaration relates correspond to the relevant basic safety and health requirements of Directives **2006/42/EC** (Machinery Directive), **2004/108/EC** (EMV-Directive) and **2000/14/EC** (noise directive) incl. modifications. For the relevant implementation of the safety and health requirements mentioned in the Directives, the following standards and/or technical specification(s) have been respected:

DIN EN 60745-1 (VDE 0740-1):2010-01; EN 60745-1:2009
DIN EN 60745-1 Ber.1 (VDE 0740-1 Ber.1):2010-04; EN 60745-1
Corr.: 2009; EN 60745-1/A11:2010
DIN EN 60745-2-13 (VDE 0740-2-13):2011-07; EN 60745-2-
13:2009+ A1:2010
DIN EN ISO 12100:2011-03; EN ISO 12100:2010
DIN EN 55014-1 (VDE 0875-14-1):2012-05; EN 55014-1:2006
+A1:2009 + A2:2011
DIN EN 55014-2 (VDE 0875-14-2):2009-06; EN 55014-2:1997+
A1:2001+ A2:2008
DIN EN 61000-3-2 (VDE 0838-2):2010-03; EN 61000-3-2:2006+
A1:2009 + A2:2009
DIN EN 61000-3-11 (VDE 0838 Teil 11):2001-04; EN 61000-3-11:2000
Requirements of category I, Engineering type licence No. 1026 MSR,
VDE Offenbach 0366

The year of manufacture is printed on the nameplate and can be additionally retrieved via the consecutive serial number.

measured acoustic capacity level 101,7 dB(A)
granted acoustic capacity level 103 dB(A)

Conformity assessment method to annexe V / Directive 2000/14/EC

Münster, den 13.03.2013 

Gerhard Knorr, Technical Management Ikra GmbH
CE Conformity Officer Mogatec GmbH

Maintenance of technical documentation:
Gerhard Knorr Kärcherstraße 57 D-64839 Münster

14. Warranty

Independently from the dealer's obligations towards the end customer resulting from the purchasing contract, we provide a warranty for this electrical tool in accordance with the following terms:

In the case of proper use of your chainsaw we grant a guarantee 36 months on the motor and housing as well as on all electrical components. In the case of a commercial use or if the device is professionally rented, the warranty period is reduced to 12 months. Wearing parts and damages caused by wrong accessories, non-original replacement parts, employment of force, strokes or breaking as well as by the mischievous over-stressing of the motor are not covered by this warranty.

Within the warranty period, damaged tools can be sent to the service address shown. You will be provided with a new or repaired tool at no charge.

After the termination of the warranty period, you still have the possibility to send damaged devices to the address shown to have them repaired. Any repairs occurring after the termination of the warranty period will be charged. In case of any actions carried out at the tool by unauthorised persons, the warranty will be held void.

Expenses for postage and shipment as well as any subsequently developing expenses must be borne by the customer.

This does not affect your statutory rights.

15. SERVICE

AUS Tel.: 1800 909 909

Internet: www.globalpowerbrands.com

email: help@globalpowerbrands.com

DE  - Service,

Mogatec Moderne Gartentechnik GmbH
Im Grund 14, D - 09430 Drebach

Tel.: + 49 180 3664283

(0,09 €/min. im dt. Festnetz, max. 0,42 €/min. aus deutschen Mobilfunknetzen)

od. + 49 3725 449-335

Fax: +49 3725 449-324



Warranty Certificate

Congratulations! You have made an excellent choice of this quality product. Our commitment to quality also includes our service. Should you, contrary to expectations, experience defects due to manufacturing faults, ALDI will provide you with a warranty against defects as follows:

Warranty

The product is guaranteed to be free from defects in workmanship and parts for a period of 36 months (dependant on product) from the date of purchase. Defects that occur within this warranty period, under normal use and care, will be repaired, replaced or refunded at our discretion. The benefits conferred by this warranty are in addition to all rights and remedies in respect of the product that the consumer has under the Competition and Consumer Act 2010 and similar state and territory laws.

Our goods come with guarantees that cannot be excluded under the Australian Consumer Law. You are entitled to a replacement or refund for a major failure and for compensation for any other reasonably foreseeable loss or damage. You are also entitled to have the goods repaired or replaced if the goods fail to be of acceptable quality and the failure does not amount to a major failure.

Proof of Purchase

This warranty is valid for the original purchase and is not transferable. Please keep your purchase docket, tax invoice or receipt as the best proof of purchase, and as proof of date on which the purchase was made.

Extent of Warranty

This warranty is limited to defects in workmanship or parts. All defective products or parts will be repaired or replaced. This warranty does not cover batteries or any other consumable items.

Normal Wear and Tear

This warranty does not cover normal wear and tear to the products or parts.

Exclusions

This warranty does not cover:

- Any defects caused by an accident, misuse, abuse, improper installation or operation, lack of reasonable care, unauthorised modification, loss of parts, tampering or attempted repair by a person not authorised by the distributor.
- Any product that has not been installed, operated or maintained in accordance with the manufacturer's operating instructions provided with the product.
- Any product that has been used for purposes other than domestic use.
- Any damage caused by improper power input or improper cable connection.

To Make a Claim

This warranty against defects is provided by ALDI Stores, Locked Bag 56, St Marys Delivery Centre, NSW 2760, Phone (02) 9675 9000. If a defect in the goods appears within 36 months, you are entitled to claim a warranty, please contact or send all warranty claims to:

Globalpowerbrands Pty Ltd
Building 2, 991 Mountain Highway
Boronia Vic 3155

Telephone: 1800 909 909

Email: help@globalpowerbrands.com

When making a return, please ensure the product is properly packaged so as to ensure that no damage occurs to the product during transit.

Please provide the original or a copy of the proof of purchase. Also please make sure you have included an explanation of the problem.

Please note that the costs of making a warranty claim, including any return postage, will be covered by the supplier identified above.

Please note upon receiving your warranty claim, the supplier will send, via the post or email, a repair and refurbished goods or parts notice. Please provide your email address and advise the supplier, if you wish to obtain a repair and refurbished goods or parts notice via email.

After Sales Support

Telephone: 1800 909 909

Internet: www.globalpowerbrands.com email: help@globalpowerbrands.com





Warranty Details

Product Name Electric Chainsaw

Brand Name Gardenline

Product Number 90813

Model Number KSI 2200

Serial Number

Name

Address

Email

Daytime Tel No

Date of purchase

We recommend that you attach a photocopy of your receipt, showing the date of purchase, to this Warranty certificate and **keep for your reference.** Please do not send to the address below.

In the event of a product fault, please call the Customer Service hotline. Please ensure that you have the product details (as shown on this card) at hand so that we are able to respond as quickly and efficiently as possible.

www.globalpowerbrands.com

email: help@globalpowerbrands.com

After Sales Support

Telephone: 1800 909 909

Internet: www.globalpowerbrands.com

email: help@globalpowerbrands.com



