



User Manual

GARDENLINE®
Essentials

53942 45CC PETROL CHAINSAW



Product
Info



+ VIDEO

<https://help.tools/>

Read all safety warnings and all instructions thoroughly before operating this product.

Ensure you keep your manual in a safe place for future reference.

IM Ed8, 09/2018



QR codes take you where you want to go quickly and easily

Whether you require product information, spare parts or accessories, details on warranties or after sales service, or if you want to watch a product demonstration video, our QR codes will take you there in no time at all.

What is a QR code?

A QR-code (QR=Quick Response) is a type of matrix that can be read with a smartphone camera and that contains a link to a website or contact details, for example.

Advantage: You are not required to manually enter a website address or contact details.

How it works

To scan the QR code, all you need is a smartphone with QR codes reader software and an Internet connection*. This type of software can be downloaded for free from your smartphone's app store.

Try it out now

Just scan the QR code with your smartphone and find out more about the Aldi product you have purchased*.



* Depending on your tariff you may be charged for the connection.

Contents

| | |
|---|-----------|
| Pack contents / parts | 2 |
| Intended use of the 45cc Petrol Chainsaw | 2 |
| Contents of carton | 2 |
| Description of Symbols | 3 |
| General Safety Warnings | 4 |
| Additional Safety Rules for Petrol Chainsaws | 7 |
| Parts List | 10 |
| Assembly | 14 |
| Changing / Replacing the Guide Bar and Chain | 14 |
| Preparation | 18 |
| Filling up with Fuel and Oil | 18 |
| Mixing Fuel | 19 |
| Fuelling the Chainsaw | 20 |
| Adding Chain Oil | 20 |
| Operation | 21 |
| Starting the Chainsaw | 21 |
| Stopping the Chainsaw | 23 |
| Checking the Oil supply | 23 |
| Adjusting the Carburettor | 23 |
| Checking the operation of the Clutch | 24 |
| Re-setting Chain brake | 24 |
| Operation Warnings | 25 |
| Vibration | 25 |
| Helpful hints | 25 |
| Guard against kickback | 26 |
| Chainsaw Applications | 27 |
| Bucking Spike | 27 |
| Felling a tree | 27 |
| Limbing | 28 |
| Bucking | 29 |
| Pruning | 27 |
| Maintenance | 30 |
| Replacing Spark Plug | 30 |
| Chain Sharpening | 31 |
| Guide Bar Wear | 31 |
| Air Filter | 32 |
| Guide Bar | 32 |
| Vents | 33 |
| Servicing | 33 |
| Transportation & Storage | 33 |
| Warranty | 34 |
| Environmental Protection | 34 |
| What your 3 year warranty means | 34 |
| Service Support | 35 |
| Accessories & After Sales Parts | 35 |
| Troubleshooting | 36 |
| Specifications | 37 |

Pack contents / parts

Congratulations on the purchase of your Gardenline® 45cc Petrol Chainsaw. When you open your packaging, first remove all items and check there are no parts damaged or missing. If you find anything wrong, do not operate the product until the parts have been replaced or the fault has been rectified. Failure to do so could result in serious personal injury.

IMPORTANT INFORMATION.

NOTE: This is a 2 stroke Chainsaw and requires pre-mixing fuel with 2-stroke oil **BEFORE** starting. Fresh unleaded fuel must be used in this unit. Do NOT use Ethanol based fuels.

NOTE: First time users or inexperienced operators pay particular attention to the operation of the Chainsaw, including details of starting and stopping and correct use of the Chainsaw on pages 21-23, as well as the maintenance instructions on pages 30-33.

Intended use of the 45cc Petrol Chainsaw

NOTE: This product is for private domestic DIY use only. It is not suitable for commercial or trade use.





















This Chainsaw has been designed for felling small to medium sized trees, cutting firewood and clearing and pruning branches.

Contents of carton

| | |
|--|-----------------------------|
| 1 x Petrol Chainsaw (with brake on) | 1 x Instruction Manual |
| 1 x Bucking Spike (fitted) | 1 x Quick Start Guide |
| 1 x 16" Bar and Chain (fitted) | 1 x Warranty Card & details |
| 1 x Bar Cover (fitted) | 1 x Service Agent listing |
| 1 x Fuel Mix Container | |
| 1 x Combination Tool (Spark Plug Spanner / Flat Blade Screwdriver) | |

Description of symbols

The instruction manual, rating plate, or on the product itself, may show these symbols. These represent important information about the product or instructions on its use.

-  Conforms to relevant standards for electromagnetic compatibility.
-  Wear hearing protection, eye protection and headwear protection.
-  Wear safety footwear.
-  Wear safety gloves.
-  Warning.
-  Read these instructions for use carefully.
- PULL**  **Choke control**
Start position (choke closed).
Run position (choke open).
-  Use at a distance of at least 15m from other people.
-  Explosive material.
-  Extremely hot surface. Do not touch a hot muffler, gear box or cylinder, you may get burned. These parts get extremely hot from operation and remain hot for a short time after the unit is turned off.
-  Do not put in water, or be subject to rain or wet conditions.
-  Fuel Tank.
-  Chain oil tank.
-  Pull recoil starter up and away from unit.
-  Warning! Danger of kickback.
-  Use the chainsaw with 2 hands.
-  Chain direction.
-  Chain Oil Flow adjustment direction.
- H** = HIGH (Fast) run adjustment screw.
- L** = LOW (Slow) run adjustment screw.
- T** = Idling adjusting screw.
-  Setting the switch to the "down" position will immediately stop the unit.
-  Chain brake direction.
-  Noise label rating 115 dB(A). You must wear ear protection at all times.

Tool Free function

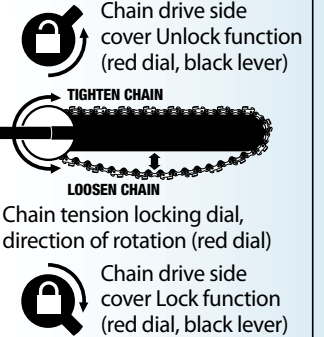

General safety warnings



WARNING! Read all safety warnings and all instructions. Failure to follow the warnings and instructions may result in fire and/or serious injury.

The word power tool used in the following warnings and throughout this manual refers to BOTH electrical power tools and ALSO petrol driven power tools.

This unit may not be used by people (including children) with reduced physical, sensory or mental capacities, with a lack of experience and without the appropriate knowledge, unless they are supervised by someone who is responsible for their safety or have been instructed by such a person with regard to how the unit is to be operated. Children should be supervised to ensure that they do not play with the device.

Save all warnings and instructions for future reference

1. Work area safety

- a. **Keep work area clean and well lit.** Cluttered or dark areas invite accidents. Rags, cloths, cord, string and similar items should never be left around the work area.
- b. **Do not operate power tools in explosive environments, such as in the presence of flammable liquids, gases, or dust.** Power tools create sparks, which may ignite the dust or fumes.
- c. **Keep children and bystanders away while operating a power tool.** Distractions can cause the operator to lose control.

2. Personal safety

- a. **Stay alert, watch what you are doing and use common sense when operating a power tool.** Do not use a power tool while you are tired or under the influence of drugs, alcohol or medication. A moment of inattention while operating power tools may result in serious personal injury.
- b. **Use personal protective equipment. Always wear eye protection.** Protective equipment such as dust mask, non-skid safety shoes, hard hat, or hearing protection will reduce personal injuries.
- c. **Prevent unintentional starting.** Ensure the switch is in the “off” position before connecting to power source and/or battery pack, picking up or carrying the tool. Carrying power tools with your finger on the switch or energising power tools that have the switch on invites accidents.
- d. **Remove any adjusting key or wrench before turning the power tool on.** A wrench or key left attached to a rotating part of the power tool may result in personal injury.
- e. **Do not overreach.** Keep proper footing and balance at all times. This enables better control of the power tool in unexpected situations.
- f. **Dress properly. Do not wear loose clothing or jewellery.** Keep your hair, clothing and gloves away from moving parts. Loose clothes, jewellery or long hair can be caught in moving parts.
- g. **If devices are provided for the connection of dust extraction and collection facilities, ensure these are connected and properly used.** Use of dust collection can reduce dust-related hazards.

General safety warnings

3. Power tool use and care

- a. **Do not force the power tools.** Use the correct power tool for your application. The correct power tool will do the job better and safer at the rate for which it was designed.
- b. **Do not use the power tool if the switch does not turn it “on” and “off”.** Any power tool that cannot be controlled with the switch is dangerous and must be repaired.
- c. **Store idle power tools out of the reach of children and do not allow persons unfamiliar with the power tool or these instructions to operate the power tool.** Power tools are dangerous in the hands of untrained users.
- d. **Maintain power tools with care.** Check for misalignment or binding of moving parts, breakage of parts and any other condition that may affect the power tool’s operation. If damaged, have the power tool repaired before use. Many accidents are caused by poorly maintained power tools.
- e. **Keep cutting tools sharp and clean.** Properly maintained cutting tools with sharp cutting edges are less likely to bind and are easier to control.
- f. **Use the power tool, accessories and tool bits etc. in accordance with these instructions, taking into account the working conditions and the work to be performed.** Use of the power tool for operations different from those intended could result in a hazardous situation.

Additional safety rules for Petrol Chainsaws

- Never cut into the ground.
- Never cut into wire fences.
- Never cut into saplings.
- Never cut into prepared wood.
- Use the chainsaw to cut only wood.
- It is advisable to provide a support for the chainsaw when cutting branches. Do not cut using the bar point and beware of branches under tension.
- Children under 18 must not use chainsaws.
- Keep people away from the chainsaw when in use.
- Check the following conditions before beginning work:
 - There should be no people in the felling area.
 - Make sure there is a second person within calling distance.
 - The working area should be free from obstacles.
- Wear suitable clothes which do not hinder movement.
- Use specific protection during operations involving head, hands, feet, eyes and ears.
- It is recommended the use of a helmet with a visor during felling, branch cutting and chopping operations.
- Wear gloves with an external protection when using the chainsaw.
- Use ear protection to prevent hearing injuries.
- Wear safety boots when using the chainsaw.
- During transport the brake must be applied to avoid accidental start-up.
- Do not use the chainsaw in rainy or windy conditions or in poor light.
- Find a suitable position before beginning work.
- When working on slopes, the saw operator must stand beside or above the wood to cut, i.e. felled trees.
- Use the chainsaw holding it firmly with both hands.

- Make a wedge-shaped cut before felling the tree, then the felling cut leaving a hinge for the felling direction.
- Beware of any falling branches after felling operations.
- Beware of wood splinters when cutting chopped wood.
- Ensure your chainsaw is suitable for the job.
- Never work above shoulder level or reach out to cut a branch: ensure you have stable footing at all times.
- Do not operate in a hazardous location. Such areas include where there is a risk of explosion of petrol fumes, leaking gas or explosive dust.
- Do not operate in a confined area. Exhaust gases, smoke or fumes could reach dangerous concentrations.
- Protect your tool. This chainsaw is NOT WEATHERPROOF and should not be left stored for periods of time where it is exposed to direct sunlight, high ambient temperature and damp, wet or high humidity conditions.
- Take care not to spill fuel. When refuelling the chainsaw ensure that the motor has been switched off. Prevent the spilling of fuel as this may also ignite with the hot motor. Never refuel whilst the engine is running.
- Be careful where you store the chainsaw. Store the tool in a dry area away from flammable liquids.
- Ensure you keep a safe distance from bystanders. The chainsaw emits exhaust fumes.
- Operating instructions and instructions for common cutting tasks, including the use of personal protection equipment, the need for adequate training and the risks involved when operating the unit should not be undertaken while tired, ill or under the influence of alcohol or other drugs.

NOTE: Tree felling should not be attempted by un-trained operators. Ensure you are familiar with the instructions in the manual before undertaking this task.

- Ensure you use a 2-stroke oil / unleaded fuel mix making sure that you mix 40 parts unleaded fuel to 1 part 2-stroke oil. If not, the engine will overheat and cause damage to your chainsaw. We recommend ALDI GARDENLINE Synthetic 2 Stroke Oil.
- Never fill fuel tank indoors. Never fill fuel tank when engine is running or hot. Do not smoke when filling fuel tank.

Kickback safety precautions

- Kickback may occur when the tip of the guide bar touches an object, or when the wood closes in and pinches the saw chain.
- If the bar tip or point contacts, it can produce a rapid reverse reaction, kicking the guide bar up and back towards the operator. This is known as rotational kickback.
- Pinching the saw chain along the top of the guide bar may push the guide bar rapidly back towards the operator. This is known as pinch kickback.
- Either of these reactions can cause loss of control of the saw, resulting in serious personal injury.
- Do not rely exclusively on the safety devices built into your saw. Take the following steps to help avoid accident or injury:
 - Reduce the element of surprise by understanding what causes kickback.
 - Keep a firm grip on the chainsaw using both hands, the right hand on the rear handle and the left hand on the front handle when the motor is running. A firm grip will help maintain control. Do not let go whilst the motor is running.
 - Make sure that the area of operation is free of obstructions. Do not let the point of the guide bar contact a log, branch or any other object.
 - Use high speeds when cutting.
 - Do not overreach or cut above shoulder height.
 - Carefully follow the sharpening and maintenance instructions given in this manual.
 - Use only replacement bars and chains specified by the manufacturer.

DANGER! BEWARE OF KICKBACK!



WARNING! Kickback can lead to dangerous loss of control of the chainsaw and result in serious or fatal injury to the saw operator or to anyone standing close by. Always be alert. Rotational kickback and pinch kickback are major chainsaw operational dangers and the leading cause of most accidents.



Wear hearing protection, eye protection and headwear protection.



Wear safety footwear.



Wear safety gloves.

Parts List

- 1. Rear handle
- 2. Safety lever
- 3. Throttle trigger
- 4. On/Off switch
- 5. Chain tensioning lock
- 6. Oil tank
- 7. Oil tank cap
- 8. Fuel tank
- 9. Fuel tank cap
- 10. Combination choke control / throttle lock knob
- 11. Recoil starter
- 12. Top handle
- 13. Front guard / chain brake
- 14. Air filter
- 15. Air filter cover
- 16. Air filter cover knob
- 17. Spark plug / Spark plug cover
- 18. Bucking Spike / Spiked Bumper
- 19. Guide bar
- 20. Chain



- 21. Muffler
- 22. Tool free (TF) chain tensioning dial (red)
- 23. Chain drive side cover
- 24. Chain drive side cover Tool Free (TF) locking dial lever (red dial, black lever)
- 25. Idling adjustment screw
- 26. HIGH (Fast) run adjustment screw
- 27. LOW (Slow) run adjustment screw
- 28. Chain catcher
- 29. Drive sprocket
- 30. Chain tensioner pin
- 31. Bar cover
- 32. Fuel mix container
- 33. Combination Tool (Spark Plug Spanner / Flat Blade Screwdriver)
- 34. Clutch / Brake assembly (internal)
- 35. Tool Free Assembly
- 36. Priming bulb

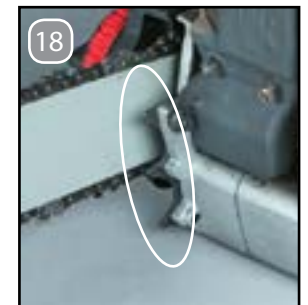
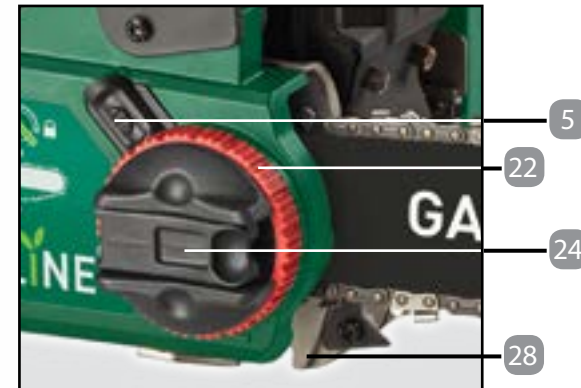

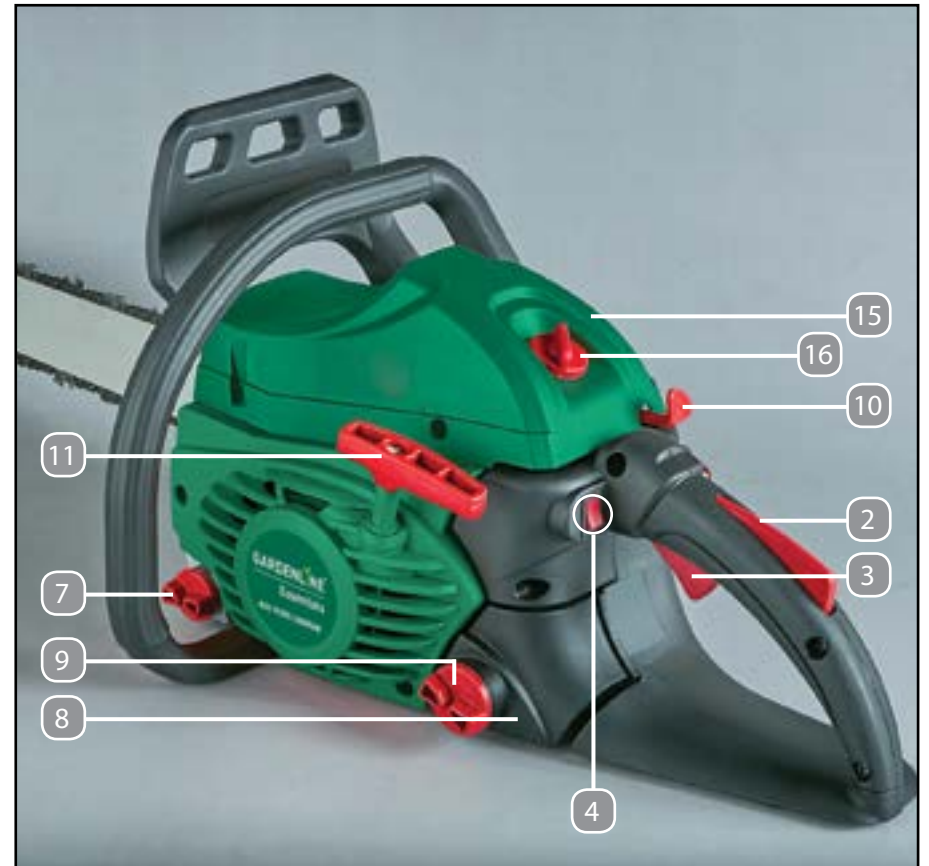
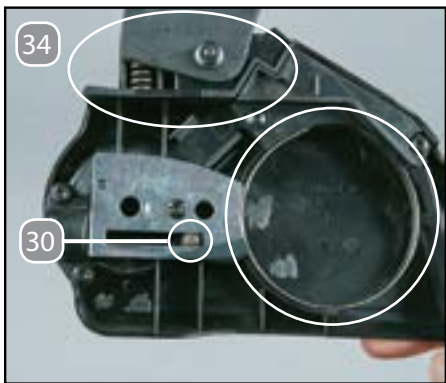
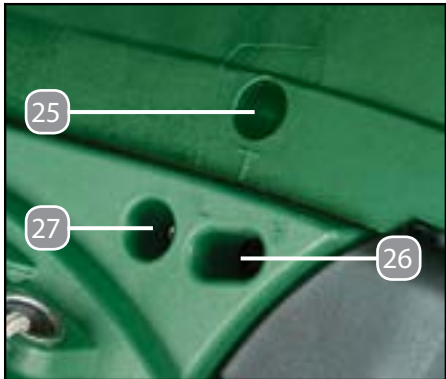
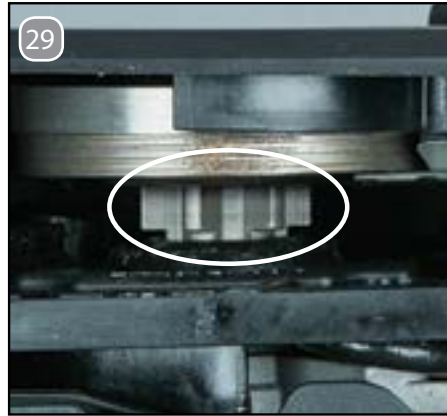
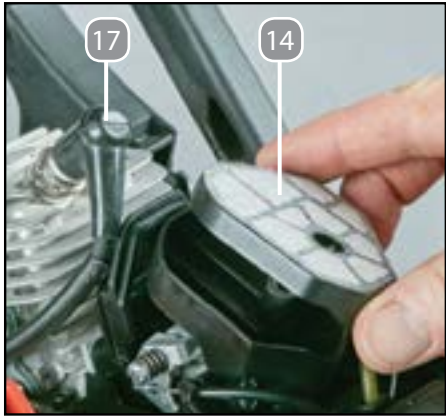

Assembly

This chainsaw comes fully assembled in the box and does not require any pre-assembly.

Replacing/Re-Installing the Guide Bar & Chain

WARNING: The chain has sharp edges. Use work gloves for safety.

WARNING: Ensure the engine is switched off when making any adjustments to the chain and bar.

IMPORTANT: The front guard / chain brake (13) must be disengaged when replacing / reinstalling the guide bar (19) and/or chain (20).

1. Place the chainsaw on a flat and secure surface and check that the chain brake (13) is disengaged/off (Fig A).
2. To remove the chain drive side cover (23) push out the black locking lever (24) located in the middle of the tool free assembly (35) (Fig B). Whilst pressing the black chain tensioning lock (5) rotate the chain drive side cover red locking dial (24) using the lever in an anti-clockwise direction, (as shown marked on the dial) 1-2 turns until the chain drive side cover (23) is loose enough to remove (Fig C).

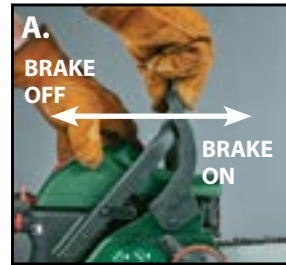
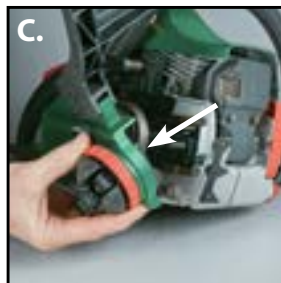
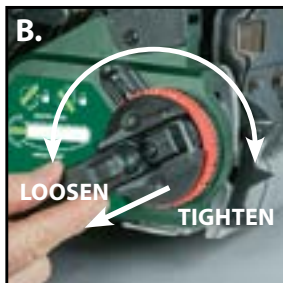

NOTE: If the chain (20) is still tight you may turn anti-clockwise a further couple of turns.

3. Remove the existing guide bar (19) and chain (20) from the chainsaw.
4. Place the chain (20) around the drive sprocket (29) loosely with the chain links in the direction shown on the guide bar (19) (Fig D).
5. Insert the new guide bar (19) into position over the 2 studs (one threaded and one plain), and on a slight angle upwards, and push the guide bar (19) towards the drive sprocket (29) to easily place the chain (20) around the guide bar (19) (Fig E).

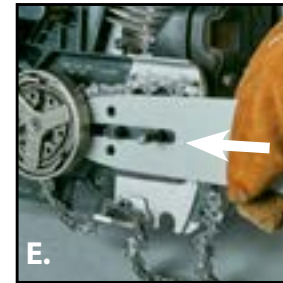

6. To fit the chain (20), start by placing the chain (20) around the nose sprocket of the guide bar (19) ensuring the chain (20) is fully located on the drive sprocket (29) wheel (Fig F), and also fully in the channel around the nose of the bar (Fig G).
7. With one hand, extend OUTWARD the guide bar (19) to remove all slack of the chain (20) and thus ensuring the chain (20) does not jump out of the narrow drive sprocket (29) on the chainsaw. With outward tension on the bar, fit the chain (20) into the channel of the bar completely. Only remove the outward tension on the bar when the chain (20) is completely fitted around the guide bar (19) (Fig H).

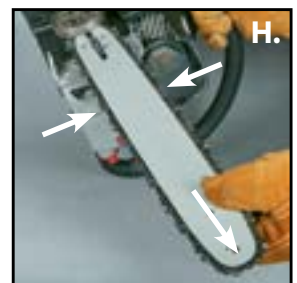
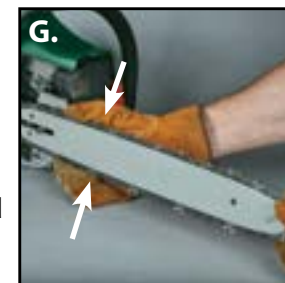

8. Prior to fitting the chain drive side cover (23), you need to ensure the chain tensioner pin (30) will locate correctly in the guide bar (19). Before fitting the chain drive side cover (23), rotate the tool free chain tensioning dial (dark green)(22) in an anti clockwise direction (Fig I) until the tensioning pin (30) is fully to the right hand side (Fig J).
9. Fit the chain drive side cover (23) over the two studs. The chain tensioner pin (30) will now sit on the guide bar (20) and needs to be moved to locate in the guide bar (19). DO NOT attempt to tighten the black locking lever (24) at this stage.
10. Applying a downward pressure with one hand and supporting the black locking lever (24) so it does not rotate (Left hand in Fig K), rotate the tool free chain tensioning dial (red) (22) in a clockwise direction (Right hand in Fig K).

NOTE: When rotating the tool free chain tensioning dial (22), (rotating in a clockwise direction), there is NO NEED to hold the chain tensioning lock.

The chain tensioner pin (30) will move forward and suddenly drop into the hole in the guide bar (19). Ensure the chain drive side cover (23) has fully dropped into position and is sitting on the bar.
11. Rotate the tool free locking dial/lever (24) in a clockwise direction ensuring the chain drive side cover (23) is being clamped to the chainsaw. DO NOT fully tighten. Tighten only to the point where the chain drive side cover (23) is just holding the guide bar (19).

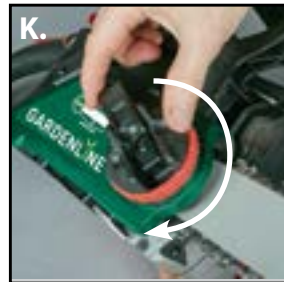
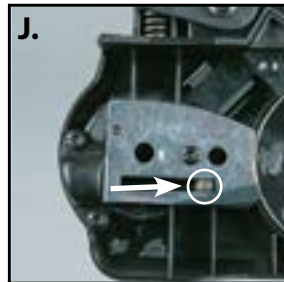
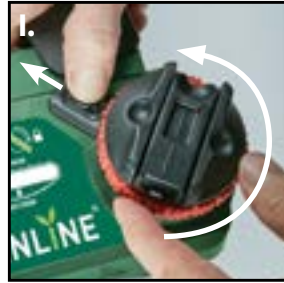

Loosening the Chain

NOTE: Ensure the engine is switched off when undertaking this task.

1. Ensure the chainsaw is located on a flat and secure surface.
2. Slide outward the chain drive side cover tool free locking dial / lever (24) and then rotate the LEVER a full 1/2 turn in an anti - clockwise direction (Fig L).
3. To loosen the chain (20), lift and hold the chain tensioning lock (5) and at the same time rotate the red tool free tensioning dial (22) in an anti -clockwise direction. When turning the red dial anti clockwise to loosen the mechanism the chain tensioning lock (5) will make a ratcheting noise (Fig O).
4. After either adjustments have been made, the chain (20) should be able to be lifted by approx. 5mm (Fig N). The chain (20), when tensioned correctly should be able to rotate around the guide bar (19) without force .
5. Once you have adjusted to a suitable tension, fully tighten chain drive side cover tool free locking lever (24) by now rotating firmly in a clockwise direction until secure, and then slide the chain drive side cover tool free locking lever (24) back to the central position (Fig P).

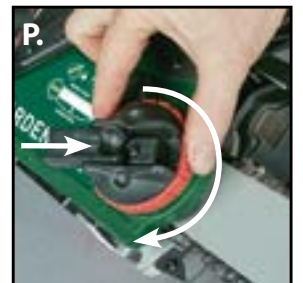
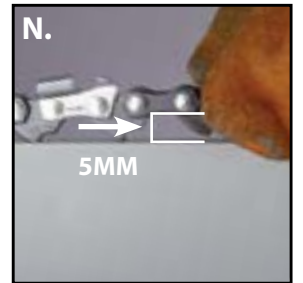
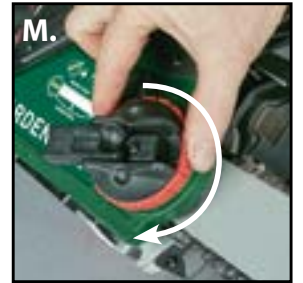

Preparation

Filling up with Fuel and Oil

WARNING: Fuel is very flammable. Avoid smoking or causing any sparks or flames near fuel. Make sure that you stop the engine and allow it to cool before refuelling the machine. Select outdoor bare ground for fuelling and move at least 15 metres away from the fuelling point before starting the engine.

It is suggested to wear safety glasses when mixing fuel.

- Only use oil that is expressly labelled for use with air-cooled 2-stroke engines. DO NOT use BIA or TCW (2-stroke water-cooling type) mixed oil.

The recommended mixing ratio is PETROL: 40, OIL: 1

- Use fresh unleaded fuel. Do not use ethanol based fuels.
- Poor quality fuel or oil may damage sealing rings, fuel lines or the fuel tank.
- Do not use waste or regenerated oil, it can damage the oil pump.

CAUTION. To maximise the lifetime of the engine, avoid the following:

- Do not use raw fuel, it will severely damage the engine very quickly.
- Do not run the tank dry at speed high, as this may cause damage to the engine.
- Do not use oil meant for 4-stroke engines, it will cause spark plug fouling, exhaust blocking and piston ring sticking.
- Do not use fuel mixtures that have been left standing for one month or more, they can cause clogging of the carburettor.
- Before storing the chainsaw for an extended period, empty the fuel tank (8), clean it then run the engine at idle to empty the carburettor.

NOTE: Do not discard an unwanted fuel container with household waste. It must be taken to an authorised repository site.

Mixing Fuel (40:1 mixing ratio)

Mixing ratio is 40:1

IMPORTANT. Use good quality air cooled 2-stroke engine oil.

This product is powered by a 2-stroke engine and requires pre-mixing fuel with 2-stroke oil.

**1 litre of petrol and 25 mls of 2-stroke oil
OR 5 litres of petrol and 125 mls of 2-stroke oil**

1. Use fresh unleaded fuel. Do not use ethanol based fuels. You must use 2-stroke oil specifically made for heavily stressed two-stroke engines.
2. Mix the fuel and oil in an approved container. Never mix fuel and oil directly into the fuel tank (8). Use the supplied fuel mixing container (32) included with this product (Fig Q).
3. Using the supplied fuel mixing container (32), fill with fuel to the 500 mark, then fill with 2 stroke oil to the 40:1 oil marking (Fig R).

WARNING. Never use any type of pre-mixed fuel/oil direct from fuel stations. This may include special blends intended for use in mopeds, motorcycles, etc.

4. Mix the fuel and oil thoroughly and also each time before fuelling.
5. Always pre-mix in small quantities. Never mix quantities larger than what will be used in a 30-day period.

NOTE: The fuel mixing container (32) provided is NOT for the storage of fuel. This container is solely for mixing of fuel and oil only.

Ensure to keep this container in a safe storage location, empty of fuel and out of reach of children.

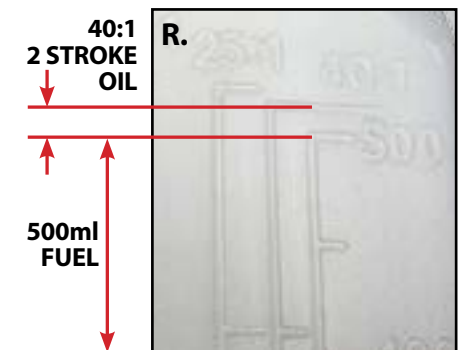

Fuelling the Chainsaw

WARNING: Always ensure the engine is turned off before undertaking this task. Never add fuel to a machine with a running or hot engine. Move at least 15m away from the refuelling site before starting engine.

Do not smoke when refuelling or operating the chainsaw.

1. Rest the chainsaw on its side so the fuel tank (8) is facing up, on the ground or a secure surface and wipe any debris from around the fuel tank (8).
2. Unscrew the fuel tank cap (9) (anti clockwise direction), and pour the fuel and oil mixture into the tank with the aid of a funnel, to about 80% of its capacity (Fig S).

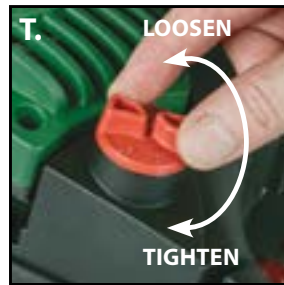

NOTE: Be careful not to spill any mixture. If this happens, wipe the spill with a clean rag.

3. Secure fuel tank cap (9) (Fig T).

Adding Chain Oil

WARNING: Always ensure the engine is turned off before undertaking this task.

WARNING: Never start work unless the chain (20) and guide bar (19) are lubricated.

1. Place the chainsaw on its side with the oil tank cap (7) facing up. Unscrew and remove the oil tank cap (7) (anti clockwise direction) (Fig U).
2. Using a funnel, fill the oil tank (6) to 80% capacity with chain oil (Fig V).
3. Fasten the oil tank cap (7) and wipe up any oil spillage.

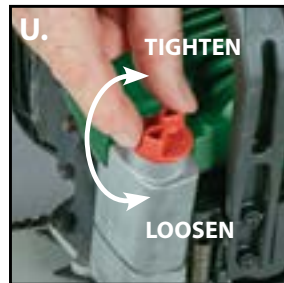

WARNING: Do not start the engine whilst the chainsaw hangs from one hand. This is very dangerous as the chain (20) may come in contact with your body and the starting action is not controlled (Fig W).

Operation

Starting the Chainsaw

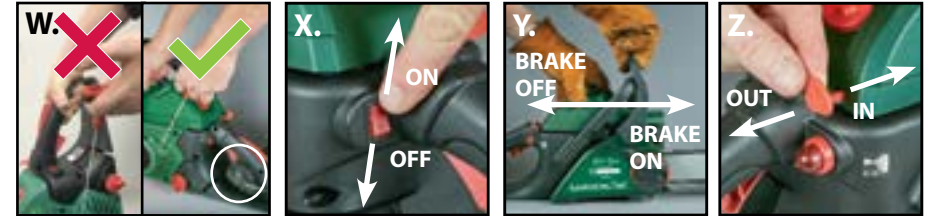

NOTE: This chainsaw is fitted with a double action recoil starter (11). This means the recoil starter only needs to be pulled at a steady medium rate and not hard vigorous pulling.

Cold starting / Out of box starting

Please follow this procedure when starting the product for the very first time, or if the unit is coming out of storage to be used.

1. Fill the fuel and oil tanks respectively per previous instructions and ensure both caps are secure. Remove the bar cover (31).
2. Turn the on/off switch (4) to the "On" position (Fig X).
3. Make sure the front guard / chain brake (13) is on when starting for safety, by pushing it firmly towards the nose of the chainsaw bar until a click is heard (Fig Y). This ensures the chain wont start spinning upon starting.
4. Press the priming bulb (36) 4 times . You will see the priming bulb (36) fill with fuel.
5. Pull the combination choke control / throttle lock knob (10) (Also engaging the throttle lock on) outwards (Fig Z).

6. Hold the chainsaw securely on the ground by placing one foot on the rear handle, one hand secure on the front handle, and using your other hand, slowly pull the recoil starter (11) 2 times so that air and fuel is drawn into the engine slowly (Fig AA).
7. Push the combination choke control / throttle lock knob (10) back inwards (As now the engine has been primed).
8. Again hold the chainsaw securely on the ground by placing one foot on the rear handle, one hand secure on the front handle, and using your other hand pull at a steady and medium rate on the recoil starter (11) (Fig AA).
9. Pull the throttle trigger upward to release the throttle lock (this is engaged when you pull the combination choke control / throttle lock knob (10) on).
10. To start cutting, release the front guard / chain brake (13), by pulling it firmly towards the back of the chainsaw until a click is heard (Fig Y).
11. Press in the safety lever (2) then the throttle trigger (3), to commence movement of the chain and start cutting (Fig AB).

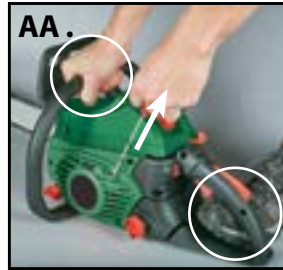

Warm / Hot Starting the Chainsaw

Follow this procedure when starting the chainsaw if you have recently stopped it and wish to restart it or have had to refuel or add oil etc.

1. Turn the on/off switch (4) to the "On" position as indicated by an "I" (Fig X).
2. Make sure the front guard / chain brake (13) is ON when starting for safety by pushing it firmly towards the nose of the chainsaw bar until a click is heard (Fig Y). This ensures the chain won't start spinning upon starting.
3. Press the priming bulb (36) 4 times or until the priming bulb (36) is full of fuel.
4. Hold the chainsaw securely on the ground, by placing one foot on the rear handle, one hand securing the front handle, and using your other hand, pull at a steady and medium rate on the recoil starter (Fig AA).

Stopping the Chainsaw

1. Release the throttle trigger (3).
2. Press down the on/off switch (4) to the "STOP" position (Fig AC).

NOTE: Especially after the first starting of the chainsaw, the tension of the chain should be checked. The chain will become loose on the first start up and will require adjustment. Refer to the "Changing / Replacing the Guide Bar and Chain" section.

Checking the Oil supply

Run the engine at medium speed and check that the chain splatters a thin line of oil which can be seen on the ground when the guide bar (19) is pointed downwards (Fig AD). **DO NOT ALLOW THE TIP OF THE BAR touch ANY surface when checking the oil flow.** Keep the chain (20) and guide bar (19) well clear of ANY surface. This visual thin line of oil is normal and is an indication the oil system is oiling the guide bar (19) and chain (20).

NOTE: For first time use the oil may take a few minutes to work through the oil system.

The oil pump is **ONLY** operating while the chain (20) is rotating so at idle the oil is **NOT** being pumped through the oil system. If there is no line of chain oil after a few minutes, stop the engine immediately and investigate the cause. The oil tank (6) could be empty or the oil supply to the chain blocked. This may require removal of the guide bar (19) and checking that the upper oil hole in the bar is clear of any blockages (Fig AE).

Adjusting the Carburettor

NOTE: It is recommended the carburettor adjustment is performed by a service centre to ensure the correct setting for both safety and performance.

The carburettor is factory set and should not require adjustment.

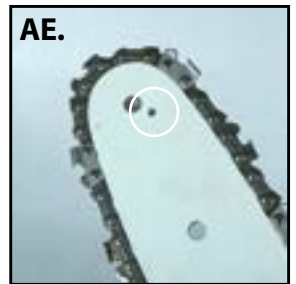

Checking the operation of the clutch.

Each time the chainsaw is started, the operation of the clutch (38) should be checked as per the following detail. The chain MUST first be checked to ensure correct tension adjustment before starting.

1. When attempting to start the chainsaw, the chain (20) should not be trying to move around the guide bar (19) under the influence of the recoil starter (11). If it is trying to rotate around the guide bar (19), STOP the starting process and take the saw to an authorised service centre.
2. If point 1 is correct and the chain (20) is not trying to rotate around the guide bar (19), start the chainsaw as per the section in the manual "Starting the Chainsaw".
3. With the chainsaw operating and at idle (throttle lock (5) NOT engaged), and ensuring the chain (20) is in a safe position with respect of other persons and any objects, release the chain brake (13).
CHECK, the chain (20) should NOT be rotating around the guide bar (19) at idle speed.
4. Operate the safety lever (2) and then accelerate the throttle trigger (3). The chain (20) should start and rotate. The harder the throttle trigger (3) is pulled, the faster the chain (20) will rotate. RELEASE the throttle trigger (3) so the motor returns to the idle condition. The chain (20) MUST stop rotating around the guide bar (19) when the motor of the saw is at idle.
5. If the chain (20) is constantly rotating when the motor of the saw is at idle, the chainsaw should NOT be used and the chainsaw should be taken to an authorised service centre for repair.
6. DO NOT use the chainsaw if the clutch (34) does not totally disengage when the motor of the saw is at idle.

Re-setting the Chain Brake

The front guard / chain brake (13) operates automatically in the event of kickback. In the event of a kickback, the guide bar (19) kicks up, the wrist of the operator's hand on the top handle knocks against the front guard / chain brake (13) causing it to move forward thus activating the chain brake (13).

To reset the front guard / chain brake (13) this can be done manually by pulling it firmly towards the back of the chainsaw until a click is heard. (Fig A).

CAUTION: Each time the chainsaw is used, check that the chain brake (13) is operating correctly.

Operation

WARNINGS:

- Always follow the safety instructions given at the front of this manual. This chainsaw must only be used for cutting wood. It must not be used for cutting other types of material. Do not use the chainsaw as a lever for lifting, moving or splitting objects.
- Do not attach the chainsaw to a fixed stand.
- Do not attach any devices to the chainsaw other than those specified by the manufacturer.
- Be aware of any local or national restrictions when using this appliance. This could include, but not restricted to, times of operation, location of operation, or work place operation.

Helpful Hints

- Do not force the chainsaw into the cut. Apply only light pressure whilst running the engine at full throttle.
- If the chain (20) gets caught in the cut, do not try to remove it by twisting the guide or pulling forcibly. Use a lever or wedge to open up the cut so that the chain is freed.

Vibration

Vibration white finger may occur in operators using hand held vibrating tools such as chainsaws. Continual vibration can cause both vascular damage and also Nerve Damage to the operator.

The following guidelines can reduce the risk:

- Limit the use of vibrating tools.
- Hold vibrating tools as loosely as possible and in varying positions.
- Ensure tools are well maintained; make sure cutting blades are kept sharp to maintain efficiency, and replace worn parts.
- Use tools correctly, and use the right tool for the job (to do the job more quickly and reduce exposure time).
- Store tools so that they do not have very cold handles when next used.
- Use anti-vibration gloves.
- Take regular breaks of at least 10 minutes every hour away from the tool.

While cutting, always:

- Run the chainsaw motor at full revs. This makes the job safer, as there is less chance of pull-in or kick-back.
- Position your body to the left of the chainsaw so if it kicks back uncontrollably, it goes over your right shoulder. Never stand in the cutting line of the chainsaw.
- Keep a firm grip with your left hand on the front handle, with your thumb securely below the handle.
- The swivel of your wrist in a kick-back situation will activate the chain brake.
- Make sure the chain is tensioned correctly.

Guard against Kickback

Check the operation of the front guard / chain brake (13) each time you use the chainsaw. Run the chainsaw at full throttle for 1-2 seconds then push the front guard / chain brake (13) forwards. The chain (20) should stop immediately. If the chain (20) is slow to stop or only slows down you must take the chainsaw to an authorised Service Agent. Disengage the front guard / chain brake (13) by pulling the front guard backwards until you hear a click (Fig A).

Do not use the chainsaw if the front guard / chain brake (13) is not operating correctly.

- Be constantly aware of the position of the upper quadrant of the blade tip. This is the part that triggers a kickback when it hits resistance.
- Never engage the upper quadrant of the guide bar (19) with whatever you are cutting and avoid contact with any hidden branches or obstructions. Ensure there is a clear work area.
- Always clear away brush, vegetation and any obstructing debris before attempting a cut that might trigger a kickback.
- Avoid cuts that will cause the chainsaw to jam in a tree trunk or limb.
- Observe the size of wood shavings, if they become dusty your chain (20) could need sharpening.

Chainsaw Applications

 **WARNING:** Do not use the chainsaw if you are tired or under the influence of drugs, alcohol or medication.

If you are unfamiliar with the following cutting procedures, ensure you fully read and understand the instructions before undertaking the task.

Bucking Spike (Fig AF)

This chainsaw is fitted with a spiked bumper (18). When downward cutting, the bumper should be spiked into the surface of the timber being cut.

This point is then used as a pivot point ensuring the cutting action is in the 1st quadrant of the bar length.

The cutting action is then performed by lifting the rear handle (1) of the chainsaw while the bucking spike (18) is the pivot in the timber.

The cutting action at the bar is then downward and the cut is made.

The bucking spike (18) is reset to a new pivot point by reducing the speed of the chainsaw to idle, withdrawing the chainsaw slightly away from the timber being cut and lowering the rear handle (1) so the bucking spike (18) is in a lower position on the timber.

Apply the bucking spike (18) to the timber in the new lower position and continue the cut in the above action.

Felling a Tree (Fig AG)

 **WARNING.** Felling a tree should only be done by trained operators.

Decide the direction in which you wish the tree to fall taking into account the direction of the wind, the position of branches, lean of the tree, ease of subsequent limbing and bucking and other factors prevalent at the time.

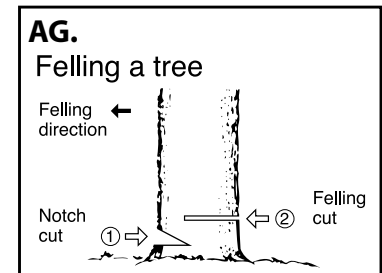
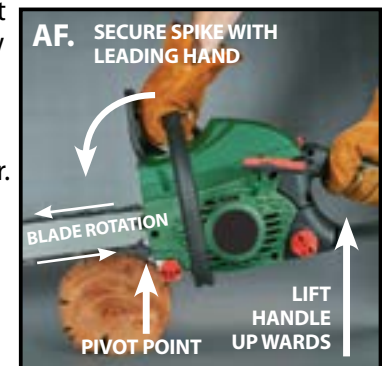

1. Clear the area around the tree and make sure that you have a good foothold and clear retreat path.
2. Ensure that others in the area are aware of the felling and ensure people and animals are well clear.
3. Make a notch cut one-third of the way into the tree on the felling side.
4. Make the felling cut on the opposite side to the initial notch and slightly higher than the notch. As the felling cut gets close to the notch cut, the tree will begin to fall.
5. Remove the chainsaw from the cut, and stop the engine with the on/off switch (4), put the chainsaw down and leave the area along the retreat path.

Limbing (Fig AH)

Limbing is the process of removing the branches from a fallen tree.

Check the direction in which a branch will bend before cutting it. Always cut on the opposite side to the bending direction so that the guide bar (19) is not pinched in the cut.

For large limbs that cannot be removed in one cut, make an initial cut from the bent side and finish by sawing from the opposite direction.

Do not remove limbs that are supporting the fallen tree on the ground until the tree has been cut into lengths.



WARNINGS: Always keep a balanced stance. Do not stand on the log. Be alert to the fact that the log may roll over. When working on a slope, always stand on the uphill side of the log.

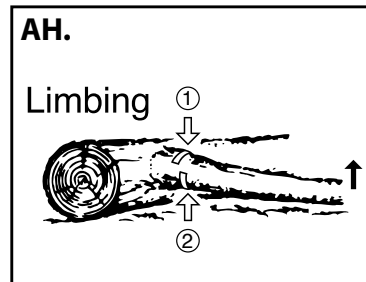

Bucking (Fig AI)

Bucking is cutting a log into lengths for easier handling.

To saw a log lying on the ground, first saw halfway, then roll the log over and cut from the opposite side. To saw the end of a log supported off the ground, first saw up from the bottom one-third through the log then finish by sawing down from the top. To saw a log in the middle of two supports holding it off the ground, first saw down from the top one-third through the log then finish by sawing up from the bottom.

CAUTION: Avoid cutting into the ground as this will very quickly dull the saw chain.

Pruning (Fig AJ)

Pruning is the removal of a limb or branch from a standing tree.



WARNINGS: Do not use an unstable foothold or ladder. Do not overreach.

Do not saw above shoulder height. Always use both hands to hold the chainsaw. First cut up from the bottom and finish down from the top.

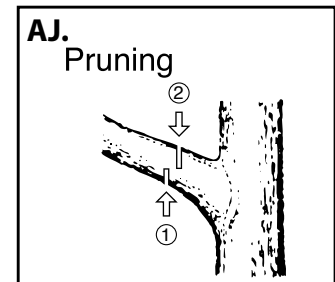
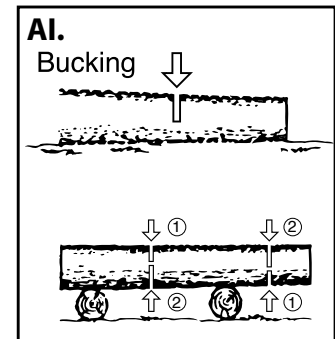

Maintenance

NOTE: This product is not suitable for repair or maintenance work by the unskilled person. The following detail explains how the product is cleaned, and basic maintenance / safety checks.

All other maintenance work must be carried out by service agents who are experienced with both the mechanical and electrical aspects of this product.

NOTE: Before cleaning your chainsaw or carrying out any maintenance procedures, make sure that the engine is off and is cool.

NOTE: Failure to maintain the following parts may result in reduced engine performance.

Disconnect the Spark plug to prevent accidental starting. Maintenance should be performed before and after each use. If the chainsaw is dropped or appears to suffer any other significant impact, it is highly recommended to perform all maintenance tasks before operation, and if there appears to be an issue, refer to the troubleshooting chart, or take to an authorised service agent.

Changing/replacing the Spark Plug

Regularly check the spark plug (17) for wear and any build-up of carbon on the electrodes. Spark plugs should be replaced every 10-15 hours of use.

1. Remove the air filter cover (15) by rotating the air filter cover knob in an anti-clockwise direction until loose. Fully remove the knob and plastic washer.



Lift the cover away from the saw housing (Fig AK).

WARNING: To avoid damage to the spark plug lead, ensure you hold the rubber cap and not by the lead itself.

2. To remove spark plug (17) first remove the rubber cap on the spark plug. Then, using the supplied combination tool (spark plug spanner) (33) turn in an anti-clockwise direction to remove.
3. Check for oil on the electrodes and clean off any excess. This can typically indicate that the fuel mixture ratio may be incorrect.
4. Use a soft wire brush to clean up carbon build up on spark plug electrodes. Replace the spark plug or reset the electrode gap to 0.6-0.7mm. Replacement spark plugs can be purchased from your local Lawnmower or small engine store.
5. Reassemble in the reverse order.

Chain Sharpening

WARNING: Always ensure the engine is turned off before undertaking this task.

Sharpen the chain regularly to maintain optimum performance of the chainsaw.

Signs of a dull chain are:

- The sawdust becomes powder-like
- Extra force is required to execute a cut
- The cut does not track in a straight line
- Increased vibration
- Increased fuel consumption

WARNING: Wear heavy gloves when handling the chain. Hold the guide bar (19) securely in a vice.

Sharpen each cutter using a sharpening file (not supplied). Always use outward strokes (Fig AL).

After sharpening, the cutters must all have the same width and length. After every 3 - 4 times use a repair centre to professionally sharpen your saw chain. They have the special tools necessary to ensure the correct cutting angles and depths are even.

The suggested sharpening angle is 30 - 35°.

Guide Bar Wear

Reverse the guide bar (19) every 8 working hours to ensure uniform wear. Check the bar rails frequently and if necessary remove burrs and square-up the rails using a flat file.

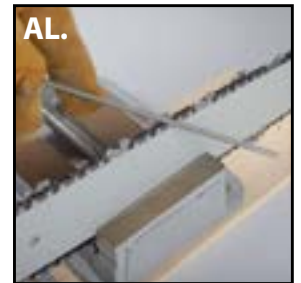

Air Filter:

1. Remove the air filter cover by rotating the air filter cover knob (16) in an anti-clockwise direction until loose. Fully remove the knob and plastic washer. Lift the cover away from the saw housing (Fig AM).
 2. Separate the air filter into its two parts (Fig AN) and clean the filter material. Dry particles can be removed by tapping on a hard surface. More stubborn dirt may require washing out the air filter (14) with warm soapy water and soft brush.
- NOTE.** BEFORE re assembly, ensure the filter material is dry.
4. Re-assemble the two halves of the air filter (14). Replace the air filter cover (15) and secure with the air filter cover knob (16) and plastic washer.

Guide Bar:

1. Take off the guide bar (19) and maintain it by removing any sawdust from the groove in the guide bar (Fig AO).
2. Make sure that the oil port is not clogged. Oil the nose sprocket at the tip of the guide bar (19) (Fig AP).
3. Check for fuel and oil leakage and loose fastenings, especially those securing the handles and the guide bar (19).
If any defects are found, take the tool to an authorised Service Agent.
4. A bar cover (31) is supplied with this chainsaw and should be fitted over the chain (20) and guide bar (19) whenever the chainsaw is not being used. This includes immediately after use, transportation and service where possible.



The chain teeth are extremely sharp and could create a safety hazard if the bar cover (31) is not fitted. Furthermore, the bar cover (31) provides protection to the chain cutting edge when the saw is not in use (Fig AQ).

WARNING: The chain has sharp edges.
Use work gloves for safety.

Vents:

1. Clean any dust away from the cooling vents as clogged vents can cause overheating.

Servicing

- It is recommended once you first use your product to get it serviced after 15 hours of use.
- From thereafter, service the product every 2 years, or every 50 hours of use if frequently used.

Transportation and Storage

Always fit the chain and bar cover (31) when the chainsaw is not in use. It is recommended to drain BOTH fuel and oil from the chainsaw on the completion of use, prior to storage or transportation.

Always sit the chainsaw on a surface where the leakage of oil will not be a problem. The chainsaw is fitted with an oil pump and there will be after use an amount of oil in the oil channels inside the chainsaw, and also in the chain and bar channel. This oil can spill on to the surface the chainsaw is sitting as it drains from the above points.

Always store the chainsaw in a area safe away from the elements of the environments, i.e. high humidity, wet locations, hot environments etc.

Storage area should also be out of reach of children of both the chainsaw, mixing bottle and all accessories.

Store the chainsaw ensuring the bar cover securely covers the chain (20) and guide bar (19).

The chainsaw should always be stored with the On/Off switch (4) in the 'STOP' position and the chain brake (13) ON.

If the chainsaw is to be stored for a long period of time it is advisable to apply a thin spray of oil over the chain (20), guide bar (19) and all exposed metal parts.

The chainsaw should be thoroughly cleaned of all wood chips, dirt etc prior to storage.



Warranty

Your new Gardenline® Chainsaw will more than satisfy your expectations. It has been manufactured under stringent Gardenline® Quality Standards to meet superior performance criteria.

You will find your new Chainsaw easy and safe to operate, and, with proper care, it will give you many years of dependable service.

CAUTION. Carefully read through this entire instruction manual before using your new Gardenline® Chainsaw .

Take special care to heed the Cautions and Warnings.

Your Gardenline® Chainsaw has many features that will make your job faster and easier. Safety, performance, and dependability have been given top priority in the development of this Chainsaw , making it easy to maintain and operate.

Use only Gardenline® replacement parts for your product. Non-conforming parts or modifications made to parts will void your warranty.

Environmental protection



Recycle unwanted materials instead of disposing of them as waste.

All tools, hoses and packaging should be sorted, taken to the local recycling centre and disposed of in an environmentally safe way.

Dispose of used motor oil in a manner that is compatible with the environment.

We suggest you take it in a sealed container to your local service station for reclamation. Do not throw it in the trash or pour it into the earth.

What your 3 year protection means

Great care has gone into the manufacture of this product and it should therefore provide you with years of good service when used properly.

In the event of product failure within its intended use over the course of the first 3 years after the date of purchase, we will remedy the problem as quickly as possible once it has been brought to our attention. In the unlikely event of such an occurrence, or if you require any information about the product please contact us via our after sales support services, details of which can be found in this manual and on the product itself. After Sales Support TEL: 1800 909 909

Service support

If you are having difficulty in using your product, you can find instructional Know How videos on our website, <https://help.tools/>, by clicking on the How to Videos link.

If you have any issues with the operation of your product, please take it with a copy of your receipt to one of our National Service Agents for repair or call us 1800 909 909 for advice.

A listing of our Service Agents is included with your product, however, you can also find our most updated listing on our website <https://help.tools/> by clicking on the Find your Service Agent link.

Accessories and After Sales Parts

The following accessories are available for purchase by visiting <https://help.tools/> or calling our customer service hotline on: 1800 909 909



1. Bar (53942-BAR)



3. Recoil Starter
(53942/PM2006H-RS)



5. Air Filter Cover
(53942/PM2006H-AFC)



2. Chain
(53942/PM2006H-CH)



4. Air Filter
(53942/PM2006H-AF)



6. Bar Cover (53942/
PM2006H-BC)

7. 51773 - ALDI 2 Stroke Full Synthetic Oil

Troubleshooting

| Problem | Possible Cause | Solution |
|---|--|---|
| Engine will not start | No spark in the spark plug (17) Flooded engine | Clean the spark plug (17). Replace the old spark plug (17) with a new one. With the on/off switch (4) off , remove spark plug (17) from the engine. Move combination choke control / throttle lock knob (10) inwards, and pull the recoil starter (11) 15 to 20 times. This will clear excess fuel from engine. Clean and reinstall spark plug (17), and air filter cover (15). Lift the on/off switch (4) to the "On" position. Pull the recoil starter (11) three times with choke control (10) at RUN. If engine does not start, move choke control (10) to CHOKE and repeat normal starting procedure. If engine still fails to start, repeat procedure with a new spark plug (17). |
| Engine starts but will not accelerate properly. | Carburettor requires adjustment. Chain brake (13) is engaged. | Refer to page 23 for adjustment, however, It is recommended this adjustment is performed by a Service Agent. Release chain brake (13). |
| Engine does not reach full speed and/or emits excessive smoke | Check oil / fuel mixture Air filter (14) is dirty Carburettor requires adjustment. Chain brake (13) is engaged. | Use fresh fuel and the correct 2-stroke oil mix ratio 40:1. Refer to fuel mixing section of manual. Clean air filter (14). Refer to page 23 for adjustment, however, It is recommended this adjustment is performed by a Service Agent. Release chain brake (13). |
| Guide bar (19) and chain (20) running hot and smoking. | Chain tension too tight. Check guide bar (19) and chain (20) assembly. Guide bar (19) and chain (20) are damaged. | Re-tension the chain (20). Refer to "Changing / Replacing" of the Guide Bar and Chain" section in manual. Inspect guide bar (19) and chain (20) for damage. |

For other issues not covered in this chart, please call Customer Service on 1800 909 909.

Specifications

| | |
|--|---|
| Engine displacement: | 45cc / 45cm ³ |
| Engine type: | Air cooled, single cylinder, 2-Stroke |
| Recommended maximum engine speed at idling: | 3,300 min ⁻¹ |
| Maximum engine speed with cutting attachment: | 12,500 min ⁻¹ |
| Maximum engine power: | 1.7KW |
| Fuel type: | Unleaded petrol/2-stroke oil (40:1) |
| Fuel tank capacity: | |
| Bar oil tank capacity: | |
| Bar and chain lubricant: | Standard bar and chain oil |
| Bar oil feed system: | Mechanical pump |
| Chain and Guide Bar Type: | 16" Sprocket Nose |
| Guide bar length: | 40cm/16" |
| Cutting Length: | 38 cm |
| Chain pitch: | 3/8" |
| Chain drive link thickness: | 0.050" |
| Maximum chain speed: | 21.2 m/s |
| Drive Sprocket # of teeth: | 6T |
| Drive Sprocket pitch: | 3/8" |
| Weight (including guide bar and chain with empty full tank): | 5.88 kg |
| (without bar and chain with empty fuel tank): | 5.06 kg |
| Spark plug: | CMR7H |
| Product Dimensions: | 79 x 24 x 28cm (L x W x H) |
| Noise label rating: | 115 dB(A) You must wear ear protection at all times. |
| A-weighted sound pressure level: | LpA: 102 dB(A) KpA: 3 dB(A) |
| A-weighted sound power level: | LwA: 112 dB(A) KpA: 3 dB(A) |
| Vibration levels (for each handle): | Front: hv,eq: 5 m/s ² , K=1.5 |
| Rear: | hv,eq: 4.43m/s ² , K=1.5 |
| This product complies with: | Safety ISO 11681-1: 2011 EMC EN ISO 14982:2009 |



ALDI guarantees that our exclusive brand products are developed to our stringent quality specifications. If you are not entirely satisfied with this product, please return it to your nearest ALDI store, within 60 days from the date of purchase, for a full refund or replacement, or take advantage of our after sales support by calling the supplier's Customer Service Hotline.



Made in China

Gardenline® is a registered trademark of ALDI Stores

DISTRIBUTED BY:

ALDI STORES

1 SARGENTS ROAD

MINCHINBURY NSW 2770

www.aldi.com.au

AFTER SALES SUPPORT



1800 909 909 (toll free)

e-mail: help@powertoolsupport.com

MODEL: 53942 • 09/2018 • PM2006H

3

YEAR WARRANTY