

Instruction Manual for Ku-band GaN 25W BUC [NJT8370 series]

Document Part Number: IM-T8370

Revision: 01

Issue Date: November 4, 2016

Copyright © 2016, New Japan Radio Co., Ltd. All rights reserved.
This instruction manual may not be reproduced, in part or in whole,
without the permission of New Japan Radio Co., Ltd.

The specifications and information regarding the products in this
instruction manual are subject to change without notice.

All statements, information, and recommendations in this
instruction manual are believed to be accurate but are presented
without warranty of any kind, express, or implied.

Users must take full responsibility for their application of any
products.

General Caution



1. NJRC strives to produce reliable and high quality microwave components. NJRC's microwave components are intended for specific applications and require proper maintenance and handling. To enhance the performance and service of NJRC's microwave components, the devices, machinery or equipment into which they are integrated should undergo preventative maintenance and inspection at regularly scheduled intervals. Failure to properly maintain equipment and machinery incorporating these products can result in catastrophic system failures.
2. To ensure the highest levels of reliability, NJRC products must always be properly handled. The introduction of external contaminants (e.g. dust, oil or cosmetics) can result in failures of microwave components.
3. NJRC offers a variety of microwave components intended for particular applications. It is important that you select the proper component for your intended application. You may contact NJRC's sales office or sales representatives, if you are uncertain about the products listed in the catalog and the specification sheets.
4. Special care is required in designing devices, machinery or equipment, which demand high levels of reliability. This is particularly important when designing critical components or systems whose foreseeable failure can result in situations that could adversely affect health or safety. In designing such critical devices, equipment or machinery, careful consideration should be given to, amongst other things, their safety design, fail-safe design, back-up and redundancy systems, and diffusion design.
5. The products listed in the catalog and specification sheets may not be appropriate for use in certain equipment where reliability is critical or where the products may be subjected to extreme conditions. You should consult our sales office or sales representatives before using the products in any of the following types of equipment.
 - * Aerospace Equipment
 - * Equipment Used in the Deep Sea
 - * Power Generator Control Equipment (nuclear, steam, hydraulic)
 - * Life Maintenance Medical Equipment
 - * Fire Alarm/Intruder Detector
 - * Vehicle Control Equipment (automobile, airplane, railroad, ship, etc.)
 - * Various Safety Equipment

General Caution (continued)

6. NJRC's products have been designed and tested to function within controlled environmental conditions. Do not use products under conditions that deviate from methods or applications specified in the catalog and specification sheets. Failure to employ NJRC's products in the proper applications can lead to deterioration, destruction or failure of the products. NJRC shall not be responsible for any bodily injury, fires or accidents, property damage or any consequential damages resulting from the misuse or misapplication of its products. **PRODUCTS ARE SOLD WITHOUT WARRANTY OF ANY OF KIND, EITHER EXPRESS OR IMPLIED, INCLUDING BUT NOT LIMITED TO ANY IMPLIED WARRANTY OF MERCHANTABILITY OR FITNESS FOR A PARTICULAR PURPOSE.**

About This Instruction Manual

This instruction manual describes Ku-band GaN 25W BUCs (Model No.: NJT8370 series) herein referred to as "the Unit".

This instruction manual provides information and instructions for installation and operation of the Unit.

This instruction manual is intended for use by trained field installers or system engineers responsible for satellite networks.

Updated instruction manual may be available from NJRC's sales group mcsales@njr.co.jp.

Contents

1. Introduction	5 - 6
2. Safety Instructions	7 - 10
3. Packing List	11
4. Overview	12
5. Physical Description	13 - 16
6. Installing	17 - 21
7. GUI of Monitor and Control.....	22
8. Maintenance	23
9. Specification	24 - 29

1. Introduction

This instruction manual is for Ku-band 16W BUCs (Model No.: NJT8319 series) .

The Unit receives a reference signal (10 MHz) and an IF signal (L-Band: 950 to 1,450 MHz or 950 to 1,700 MHz) input and transmits an RF signal (Standard Ku-band: 14.0 to 14.5 GHz or Universal Ku-band: 13.75 to 14.5 GHz) output.

The Unit comes in a single, weatherized housing rated for outdoor use. The Unit has either an N-Type or a F-type female connector input, a WR75 waveguide with grooved flange output, and MS connector for DC power input. The Unit is operated by +48 V DC power (Range: +36 to +60 V) input.

The Unit has the function of Monitor and Control which is complied with FSK communication and RS-232C interfaces

The Unit has the following line-up:

Model No.	RF Frequency	Local Frequency	IF Frequency	Saturation Output Power	IF Connector	Power Supply	Port for Voltage Input	M&C Option		
NJT8370NMK	14.0 to 14.5 GHz (Standard Ku-band)	13.05 GHz	950 to 1,450 MHz	25W Saturation (+44 dBm)	N-type	+36 to +60 V DC Power	MS Connector	FSK M&C		
NJT8370FMK					F-type			RS-232C M&C		
NJT8370NMR					N-type			FSK M&C		
NJT8370FMR					F-type			RS-232C M&C		
NJT8370UNMK	13.75 to 14.5 GHz (Universal Ku-band)	12.80 GHz	950 to 1,700 MHz		N-type					FSK M&C
NJT8370UFMK					F-type					RS-232C M&C
NJT8370UNMR					N-type					FSK M&C
NJT8370UFMR					F-type					RS-232C M&C

N J T 8 3 7 0 U N M K

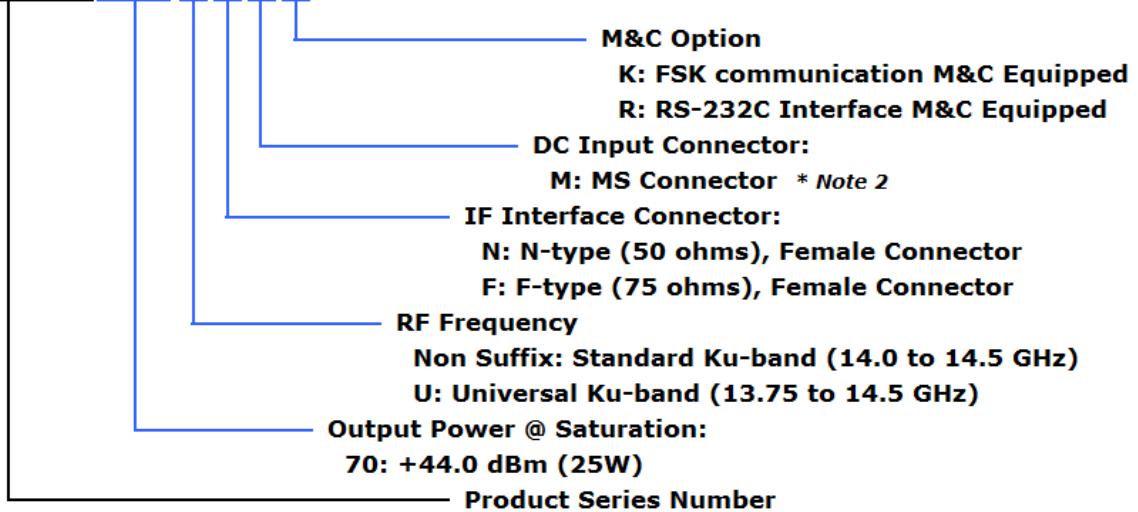









2. Safety Instructions

Use the following safety guidelines to help protect the Unit from potential damage and to help ensure your own personal safety.

DANGER, WARNING, CAUTION, and NOTE Statements

DANGER, WARNING, CAUTION, and NOTE statements are used throughout this instruction manual to emphasize important and critical information. You must read these statements to help ensure safety and to prevent product damage. The statement are defined below.

Statement	Symbol	Description
DANGER		DANGER indicates an imminently hazardous situation which, if not avoided, will result in death or serious injury.
WARNING		WARNING indicates a potentially hazardous situation which, if not avoided, could result in death or serious injury.
CAUTION		CAUTION indicates a potentially hazardous situation which, if not avoided, could result in minor or moderate injury. CAUTION may also be used to indicate other unsafe practices or risks of property damage.
NOTE		NOTE is used to notify of installation, operation, or maintenance information that is important, but not hazard-related.

Symbol	Description
	GENERIC HAZARD
	ELECTRIC HAZARD
	HOT SURFACE
	MOVING PARTS

When installing the Unit, observe the following safety guidelines.

2.1. Safety Statements

1. Opening / Removing



DO NOT dismantle this product.
Dismantlement may cause malfunction and electric shock.

2. Input Voltage



Only input a voltage within the range indicated in specified voltage.
DO operate at the input voltage of +36 to +60 V DC power.

3. RF Radiation

	A radiation hazard exists if the BUC is operated with its RF signal output unterminated. DO NOT operate the BUC without a load or termination attached to the RF signal output.
---	--

4. High Temperatures

	DO NOT touch the body, especially fins, during operating the Unit. High touch temperatures may exist, depending on load conditions.
---	--

5. Fan

	DO NOT insert your finger into the fan to avoid injury. DO NOT insert any objects into the fan. Keep any objects away from the fan. Incorrect usage may cause injury to self or others.
--	---















6. Input Level

	DO NOT input an IF signal over the range of +13 dBm maximum and a reference signal within the range of -5 to +5 dBm.
---	--

7. Operating Temperature.

	Operate the Unit within the ambient temperature range of -40 to +75 degree C, but the performance guarantee temperature range is -40 to +60 degree C.
---	---

2.2. Instruction Statements

- | | | | | | | | |
|---|---|-------------|--|---|---|--|--------------------------------------|
| <p>1. Mounting</p> | <table border="1" style="width: 100%; border-collapse: collapse;"> <tr> <td style="width: 15%; text-align: center; padding: 2px;">NOTE</td> <td style="padding: 2px;">DO NOT block the fins and air flow.</td> </tr> <tr> <td style="text-align: center;"></td> <td style="padding: 2px;">Normally the Unit should be mounted with fan face down.</td> </tr> </table> | NOTE | DO NOT block the fins and air flow. |  | Normally the Unit should be mounted with fan face down. | | |
| NOTE | DO NOT block the fins and air flow. | | | | | | |
|  | Normally the Unit should be mounted with fan face down. | | | | | | |
| <p>2. Connector</p> | <table border="1" style="width: 100%; border-collapse: collapse;"> <tr> <td style="width: 15%; text-align: center; padding: 2px;">NOTE</td> <td style="padding: 2px;">When attaching cable, DO tighten as connector with following torque:</td> </tr> <tr> <td style="text-align: center;"></td> <td style="padding: 2px;">N-type connector, 0.68 to 1.13 N · m</td> </tr> <tr> <td></td> <td style="padding: 2px;">F-type connector, 0.39 to 0.49 N · m</td> </tr> </table> | NOTE | When attaching cable, DO tighten as connector with following torque: |  | N-type connector, 0.68 to 1.13 N · m | | F-type connector, 0.39 to 0.49 N · m |
| NOTE | When attaching cable, DO tighten as connector with following torque: | | | | | | |
|  | N-type connector, 0.68 to 1.13 N · m | | | | | | |
| | F-type connector, 0.39 to 0.49 N · m | | | | | | |
| <p>3. Weatherproof</p> | <table border="1" style="width: 100%; border-collapse: collapse;"> <tr> <td style="width: 15%; text-align: center; padding: 2px;">NOTE</td> <td style="padding: 2px;">The Unit is mounted outdoors must be adequately weatherproofed.</td> </tr> <tr> <td style="text-align: center;"></td> <td style="padding: 2px;">Ensure the waveguide joints are properly sealed with the supplied o-ring (gasket). Use self-amalgamating tape to seal connectors and cable entry points from the connector to the</td> </tr> </table> | NOTE | The Unit is mounted outdoors must be adequately weatherproofed. |  | Ensure the waveguide joints are properly sealed with the supplied o-ring (gasket). Use self-amalgamating tape to seal connectors and cable entry points from the connector to the | | |
| NOTE | The Unit is mounted outdoors must be adequately weatherproofed. | | | | | | |
|  | Ensure the waveguide joints are properly sealed with the supplied o-ring (gasket). Use self-amalgamating tape to seal connectors and cable entry points from the connector to the | | | | | | |
| <p>4. Fan</p> | <table border="1" style="width: 100%; border-collapse: collapse;"> <tr> <td style="width: 15%; text-align: center; padding: 2px;">NOTE</td> <td style="padding: 2px;">The fan has its lifetime. The fan is to be replaced with a new one at appropriate interval.</td> </tr> <tr> <td style="text-align: center;"></td> <td style="padding: 2px;">The recommendation interval of replacement is five years.</td> </tr> </table> | NOTE | The fan has its lifetime. The fan is to be replaced with a new one at appropriate interval. |  | The recommendation interval of replacement is five years. | | |
| NOTE | The fan has its lifetime. The fan is to be replaced with a new one at appropriate interval. | | | | | | |
|  | The recommendation interval of replacement is five years. | | | | | | |
| <p>5. Warranty</p> | <table border="1" style="width: 100%; border-collapse: collapse;"> <tr> <td style="width: 15%; text-align: center; padding: 2px;">NOTE</td> <td style="padding: 2px;">Opening or removing any component (e.g. label, and screws) without fan equipments or sealed area will immediately void the warranty.</td> </tr> <tr> <td style="text-align: center;"></td> <td></td> </tr> </table> | NOTE | Opening or removing any component (e.g. label, and screws) without fan equipments or sealed area will immediately void the warranty. |  | | | |
| NOTE | Opening or removing any component (e.g. label, and screws) without fan equipments or sealed area will immediately void the warranty. | | | | | | |
|  | | | | | | | |

3. Packing List

The Unit is shipped in a single shipping container with the following content:

No.	Qty	Description
1.	1 unit	BUC: NJT8370NMK NJT8370FMK NJT8370NMR NJT8370FMR NJT8370UNMK NJT8370UFMK NJT8370UNMR OR NJT8370UFMR
2.	1 set	Accessory: Qty(1), Mating MS Connector Part Number: PT06E-14-12S (470) Qty(4), Hexagon Socket Head Bolt (M4x10) Qty(1), Hexagon Wrench Key (M4) Qty(2), Phillips-head Screw (M6x10) Qty(1), O-ring
3.	1 sheet	Date sheet

4. Overview

The Unit transmits an RF signal (Universal Ku-band: 13.75 to 14.5 GHz / Standard Ku-band: 14.0 to 14.5 GHz) output with up to 25W (+44 dBm) saturation.

The unique features are

- GaN Technology Amplifier inside
- High Temperature Operating:
 - * Operation Guarantee Temperature Range: -40 to +75 degree C
- RF Frequency Line-up:
 - * Universal Ku-band: 13.75 to 14.5 GHz
 - * Standard Ku-band: 14.0 to 14.5 GHz
- High Efficiency Output Power
 - * Saturation Output Power: +44 dBm
 - * ACPR: -30 dBc @ Pout = +42 dBm
 - * Power Consumption: 200 W @ Saturation Output Power
- Monitor & Control Line-up
 - * FSK Communication M&C
 - * RS-232C Interface Serial M&C
- Smaller Size & Lighter Weight
 - * Dimension: 180 (L) x 130 (W) x 80 (H) mm
 - * Weight: 2.5 kg
- LED Indicator
- RoHS Compliance

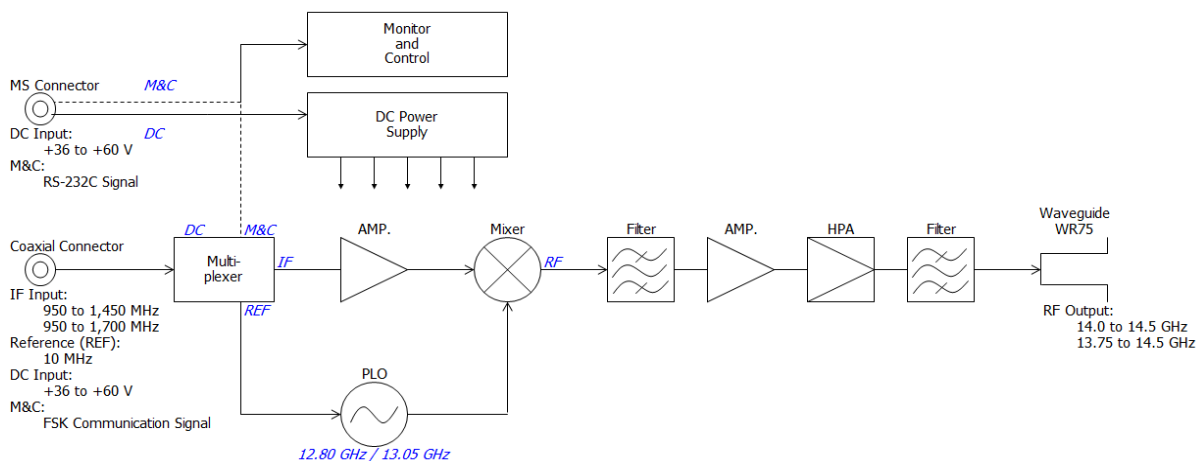

Block Diagram

5. Physical Description

This section describes appearance and outline for the Unit.

5.1. Appearance

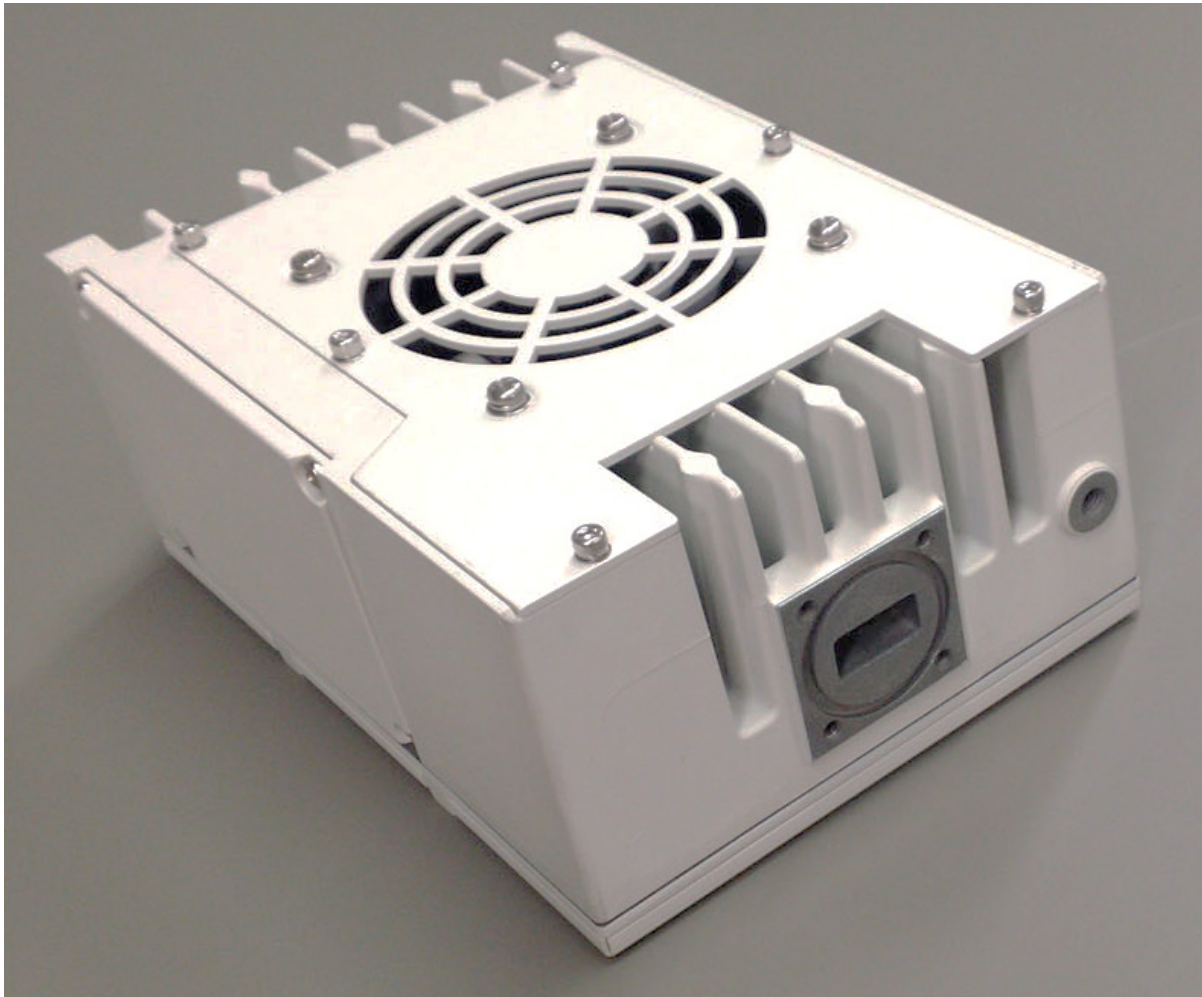

Overall Picture

5.2. Outline Drawing

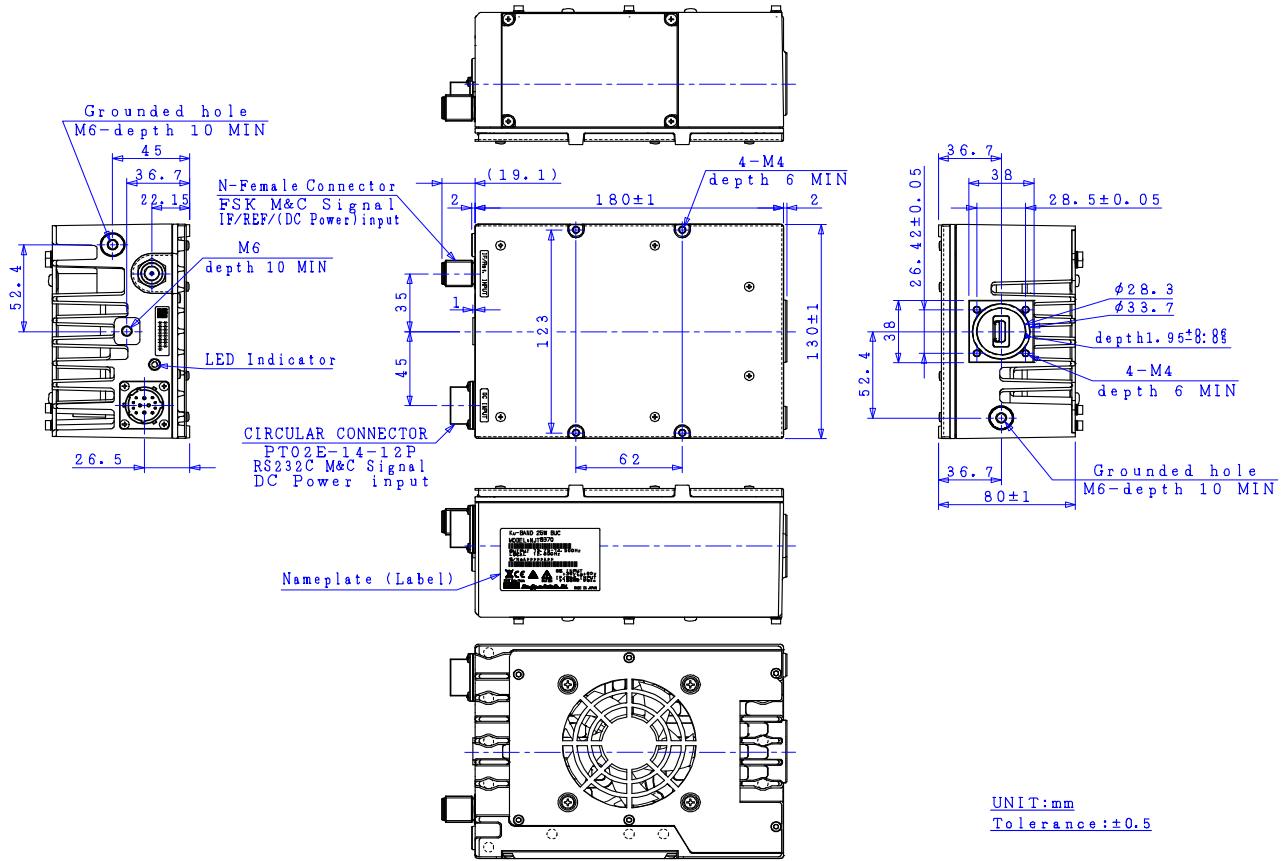

5.3. Description of Connectors, and LEDs

Item	Description	Purpose
N-type or F-type Female Connector	IF Signal Input	The Unit receives an IF signal (950 to 1,450 MHz or 950 to 1,700 MHz) via this connector.
	Reference Signal Input	The Unit receives a reference signal (10 MHz) via this connector.
	FSK Communication M&C Signal	FSK Communication M&C models are only equipped. The Unit receives / transmits the M&C signal with the FSK modulation via this connector.
Circular Connector (MS Connector)	DC Power Input	MS Connector models are only The Unit is required to supply +36 to +60 V DC power via Pin# J and K in this connector.
	RS-232C Interface M&C Signal	RS-232C Interface M&C models are only equipped. The Unit receives / transmits the M&C signal with the RS-232C interface Pin# G, H and E (or K) in this connector.
<p>Connector Information Part No.: PT02E-14-12P (025) Mating connector: PT06E-14-12S (470) Assignment:</p> <div style="display: flex; align-items: center;">  <div style="margin-left: 20px;"> <p>Pin A: N.C. Pin B: N.C. Pin C: N.C. Pin D: N.C. Pin E: GND COMMON (RS-232C) Pin F: N.C. Pin G: RS-232C TxD* Pin H: RS-232C RxD* Pin J: DC Power (+) / Prime Pin K: DC Power (-) / Return; GND COMMON (RS-232C) Pin L: N.C. Pin M: N.C.</p> </div> </div> <p>* Pin G: RS-232C TxD and Pin H: RS-232C RxD are available for only RS-232C Interface M&C models. * Do not connect the pins for N.C. and not using pins with the cable wires.</p>		

Item	Description	Purpose
WR-75	RF Output	The Unit transmits an RF signal (14.0 to 14.5 GHz or 13.75 to 14.5 GHz) via this waveguide.
LED Indicator	Local Unlock Alarm	GREEN: L.O. locked RED: L.O. unlocked (or no reference signal)
Grounded Hole	M6 hole	Common chassis ground

6. Installing

This section describes basic installation for the Unit.

6.1. Mounting Configuration

The Unit can be mounted in the feed horn of the satellite antenna.

6.1.1. Guidelines for Attachment of OMT

When attaching the OMT or the filter, you should follow the following steps:

- Step 1: Verify that the o-ring groove on the waveguide flange of the Unit is clean. Insert the enclosed o-ring (gasket) the groove as shown.

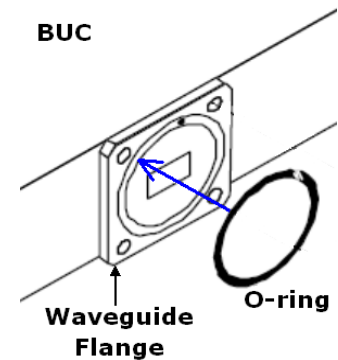

- Step 2: Secure the OMT or the filter to the Unit using the supplied enclosed bolts with 1.15 to 1.4 N·m torque as shown, when the thickness of the flange of the OMT or the filter is 3.5 to 5.0 mm.

When the thickness is not 3.5 to 5.0 mm, you should prepare

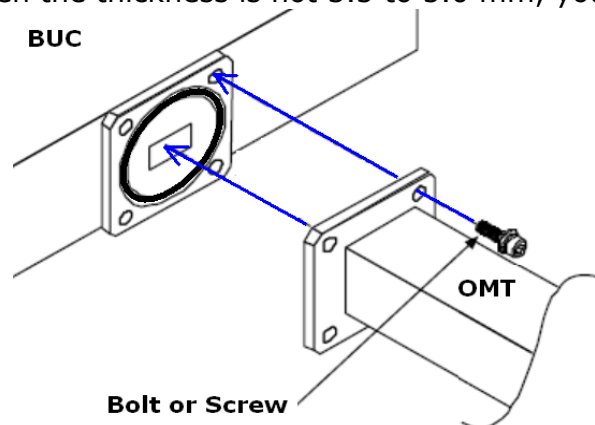

6.1.2. Guidelines for Mounting

When mounting on the OMT or the filter, you should follow the following cautions:

- DO NOT block the fins and air flow.
- Normally the Unit should be mounted with fan face down.

6.2. Connecting System

The Unit is connected two cables:

- Coaxial Cable
- Power Cable
- Wire for Common Chassis Ground / Earthing
- M&C Signal Cable

6.2.1. Connecting Coaxial Cable

The Unit receives an IF signal and a reference signal via coaxial cable from modem, is required to supply +36 to +60 V DC power , receives an FSK communication M&C signal.

Connecting the coaxial cable is proceeded with the following steps:

- Step 1: Connect the coaxial cable with N-type or F-type male connectors to the coaxial connector equipped with the Unit under following torque:
- N-type connector, 0.68 to 1.13 N·m
 - F-type Connector, 0.39 to 0.49 N·m
- Step 2: Use self-amalgamating tape to seal connector and cable entry points from the connector to the cable sheath.

	DO NOT input an IF signal over the range of +13 dBm maximum and a reference signal within the range of -5 to +5 dBm.
---	--

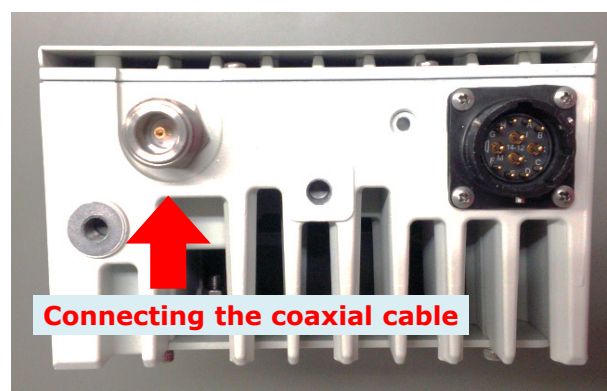

6.2.2. Connecting Power Cable

The Unit is required to supply +36 to +60 V DC power via power cable from modem or a DC power supply unit with the exception of only IF connector supplied models.

Connecting the power cable is proceeded with the following steps:

Step 1: Assemble the power cable and the supplied MS mating connector with the following assignment:

Pin J: Prime (+48 V DC Power)

Pin K: Prime Return

* Do not connect the pins for N.C. and not using pins with the cable wires.

Step 2: Connect the power cable above to MS connector equipped with a bayonet locked status.

Step 3: Use self-amalgamating tape to seal connector and cable entry points from the connector to the cable sheath.

	<p>Only input a voltage within the range indicated in specified voltage. DO operate at the input voltage of +36 to 60 V DC power at the coaxial connector on the Unit.</p>
--	--

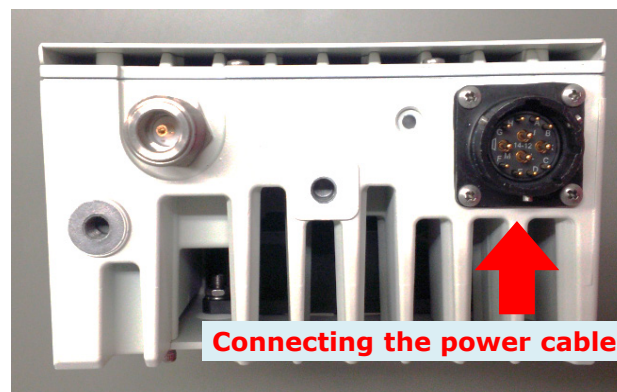

6.2.3. Wire for Common Chassis Ground / Earthing

The Unit can be had the chassis ground of the other equipment (e.g. antenna) in common or earthing.

Connecting the wire for common chassis ground / earthing is proceeded with the following steps:

Step 1: Connect the grounding/ earthing wire from ground on the other equipment or earthing point to the ground hole on connector or waveguide sides with M6 screw.

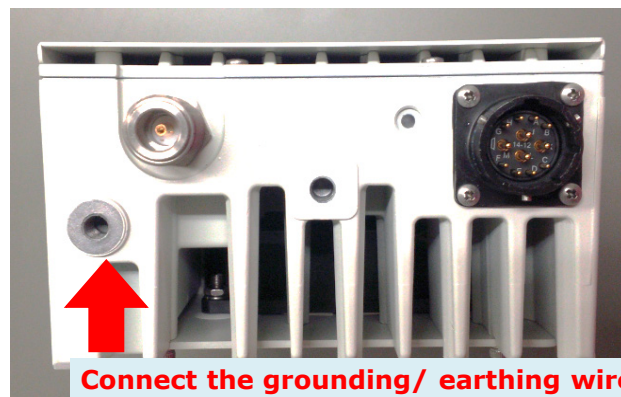

OR

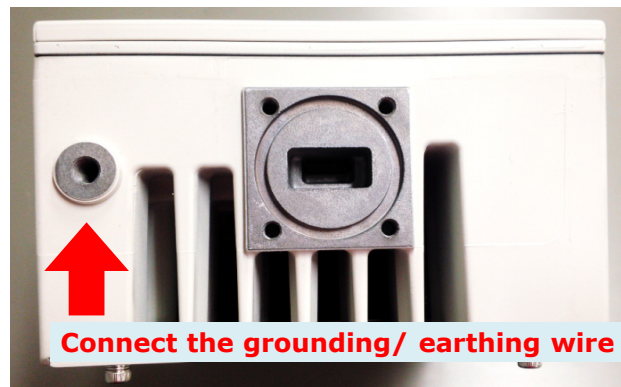

6.2.4. Connecting M&C Signal Cable

The Unit is required to supply RS-232C interface signal via signal cable from modem or M&C equipment in case that it is RS-232C interface M&C models.

Connecting the M&C signal cable is proceeded with the following steps:

Step 1: Assemble the M&C signal cable and the supplied MS mating connector with the following assignment:

Pin G: RS-232C TxD

Pin H: RS-232C RxD

Pin E or Pin K: GND COMMON (RS-232C)

* Do not connect the pins for N.C. and not using pins with the cable wires.

Step 2: Connect the M&C signal cable above to MS connector equipped with a bayonet locked status.

Step 3: Use self-amalgamating tape to seal connector and cable entry points from the connector to the cable sheath.



7. GUI of Monitor and Control

This Section describes the NJR's Graphical User Interface (GUI) of Monitor and Control.

The NJR's GUI is available for the RS-232C Interface M&C models.

The GUI uses the NJT8370-EP001 software which can be downloaded from the following NJR's website.

- Website: http://mc.njr.co.jp/eng/products/vsat/ku-buc/25w_1.html
Please download a zip file of the GUI software and decompress this

7.1. Setup

7.1.1. Connecting the RS-232C Interface

Connecting the the RS-232C Interface is proceeded with the following

Step 1: Assemble the cable and the supplied MS mating connector with the following assignment:

Pin G: RS-232C TxD

Pin H: RS-232C RxD

Pin E or Pin K: GND COMMON (RS-232C)

Step 2: Connect the MS connector and the COM port of user's PC with the above cable.

7.1.2. COM Port Setting

Set the serial communication property of your PC as follows.

Baud rate: 9600

Data bit: 8

Parity: none

Stop bit: 1

Flow control: none

7.1.3. Installing the GUI Software

The GUI Software can be installed by Setup.exe in the downloaded zip file.

The details of Installing the GUI software are mentioned in the user manual which is stored in Manual.htm in the downloaded zip file.

7.2. Starting and Operating

The details of starting and operating the GUI software are mentioned in the user manual which is stored in Manual.htm in decompressed folder.

8. Maintenance

This Section describes basic maintenance for the Unit.

8.1. Fan Field Replacement

The Unit is Forced Air by fan for cooling.

NOTE	The fan has its lifetime. The fan is to be replaced with a new one at appropriate interval.
	The recommendation interval of replacement is five years.

The fan of the Unit stop and does not operate normally, you need to replace a new fan by yourself in field. And the fan is to be replaced with a new one at five years interval.

Contact to us by phone, fax, or email, when a new fan for replacement is needed.

- Telephone: +81-49-278-1270
- Fax: +81-49-278-1234
- Email: mcsales@njr.co.jp

8.2. Power shut-down

Turn off input voltage of the power supply unit that is connected with the power cable or coaxial cable.

After confirmed the unit was in power off state, you remove the jointed connector of power cable and/or IF input cable.

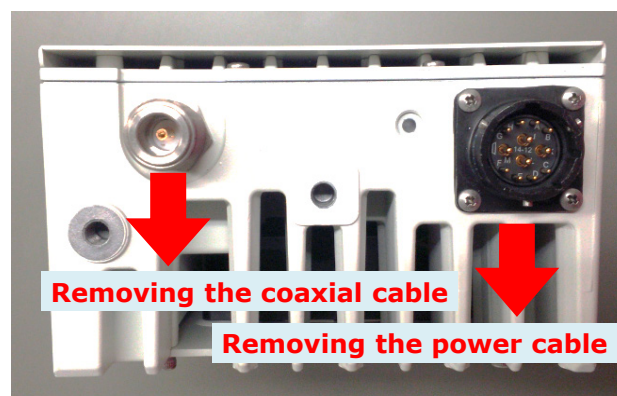

9. Specifications

The Unit is in compliance with the following specifications:

9.1. Electrical Specifications

No.	Item	Specifications
1.	Output Frequency Range <Universal Ku-band> <Standard Ku-band>	13.75 to 14.5 GHz 14.0 to 14.5 GHz
2.	Input Frequency Range <Universal Ku-band> <Standard Ku-band>	950 to 1,700 MHz 950 to 1,450 MHz
3.	Maximum IF Input Level (without damage)	+13 dBm max.
4.	Conversion Type	Single, fixed L.O.
5.	L.O. Frequency <Universal Ku-band> <Standard Ku-band>	12.80 GHz 13.05 GHz
6.	Frequency Sense	Positive
7.	Output Power @ 1dB G.C.P.	+44 dBm min. @ +25 °C +43 dBm min. over temperature
8.	Linear Gain	72 dB nom., 66 dB min.
9.	ACPR	-30 dBc typ., -26 dBc min. @ Pout = +42 dBm
10.	Requirement for External Reference [Frequency] [Input Power] [Phase Noise]	10 MHz (sine-wave) -5 to +5 dBm @ Input port -125 dBc/Hz max. @ 100 Hz -135 dBc/Hz max. @ 1 kHz -140 dBc/Hz max. @ 10 kHz
11.	L.O. Phase Noise	-60 dBc/Hz max. @ 100 Hz -70 dBc/Hz max. @ 1 kHz -80 dBc/Hz max. @ 10 kHz -90 dBc/Hz max. @ 100 kHz -100 dBc/Hz max. @ 1MHz
12.	Input Impedance <N-type Model> <F-type Model>	50 ohms nom. 75 ohms nom.
13.	Input VSWR	2 : 1 max.
14.	Output VSWR	2 : 1 max.
15.	Output Load VSWR for Non Damage	2 : 1 max.

No.	Item	Specifications
16.	DC Power Requirement [Voltage Range] [Power Consumption]	+48 VDC (+36 to +60 VDC) 120 W typ. @ No IF signal 180 W typ. @ Pout=+42dBm 200 W typ., 230 W max. @ Psat
17.	Mute	Shut off the HPA in case of L.O. unlocked, no 10 MHz reference signal, or Over temperature.*1
18.	LED Indicator	GREEN: L.O. locked RED: L.O. unlocked (or no 10 MHz reference signal)
19.	Monitor and Control	
	<FSK Communication M&C> [Interface] [Functions]	650kHz FSK Signal on IF Connector Monitor: Tx Output Power / Temperature / Tx Status / Alarm (Over temperature *1 / L.O. unlock) / Step Attenuator Control: Transmit On/Off / Step Attenuator
	[Performance]	Tx Output Power: Detector Range: 15 dB (up to P1dB) Reading Accuracy: +/- 1.0 dB Step Attenuator: Attenuator Range: 0 to 15.5 dB Attenuator Step: 0.5 dB <i>*Details are mentioned on Appendix of "Specifications Monitor & Control".</i>

No.	Item	Specifications
19.	Monitor and Control <RS-232C Interface M&C> [Interface] [Functions] [Performance]	RS-232C Interface on MS connector Monitor: Tx Output Power / Temperature / Tx Status / Alarm (Over temperature *1 / L.O. unlock) / Step Attenuator Control: Transmit On/Off / Step Attenuator Tx Output Power: Detector Range: 15 dB (up to P1dB) Reading Accuracy: +/- 1.0 dB Step Attenuator: Attenuator Range: 0 to 15.5 dB Attenuator Step: 0.5 dB <i>*Details are mentioned on Appendix of "Specifications Monitor & Control".</i>

*1: Regardless of cooling fan status, the unit will operate until status of over temperature which turn out at internal temperature of around 106 °C, and the Mute and Alarm will function at status of over temperature.

9.2. Mechanical Specifications:

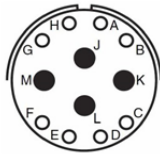
No.	Item	Specifications
1.	Input Interface [IF Connector] [DC Input *3]	<p>N-type or F-type, female connector IF / Ref. / FSK M&C Signal (/ DC) Input IF Connector or MS Connector</p> <p>- MS connector - Part No.: PT02E-14-12P (025) Mating connector: PT06E-14-12S (470)</p> <p>Assignment:</p>  <p> Pin A: N.C. Pin B: N.C. Pin C: N.C. Pin D: N.C. Pin E: GND COMMON (RS-232C) Pin F: N.C. Pin G: RS-232C TxD* Pin H: RS-232C RxD* Pin J: DC Power (+) / Prime Pin K: DC Power (-) / Return; GND COMMON (RS-232C) Pin L: N.C. Pin M: N.C. </p> <p><i>* Pin G: RS-232C TxD and Pin H: RS-232C RxD are available for only RS-232C Interface M&C models.</i> <i>* Do not connect the pins for N.C. and not using pins with the cable wires.</i></p>
2.	Output Interface	Waveguide, WR75 with Grooved Flange
3.	Cooling	Forced-air-cooled
4.	Dimension & Housing without Interface Connector	
	(L)	180 mm [7.09"]
	(W)	130 mm [5.12"]
	(H)	80 mm [3.15"]
5.	Weight	2.5 kg [5.5 lbs]

9.3. Environmental Specification:

No.	Item	Specifications
1.	Temperature Range (ambient) [Operating] [Storage]	Operation Guarantee: -40 to +75 °C Performance Guarantee: -40 to +60 °C -40 to +75 °C
2.	Humidity	0 to 100 %
3.	Altitude	15,000 feet (4,572 m)
4.	Vibration	5 G [49.03 m/s ²] (3 axis, 50 Hz to 2 kHz) 1 mm p-p (3 axis, 5 to 50 Hz)
5.	Shock	30 G [294.20 m/s ²] (3 axis)
6.	Dustproof / Waterproof	IP67 (IEC 60529)
7.	Regulatory Compliance	EU Directive (CE Marking) EMC (2004/108/EC) RoHS (2011/65/EU) Safety: EN60950-1
8.	Comply with RoHS (Restricting the use of Hazardous Substances) directives	

9.4. Product Label Specification:

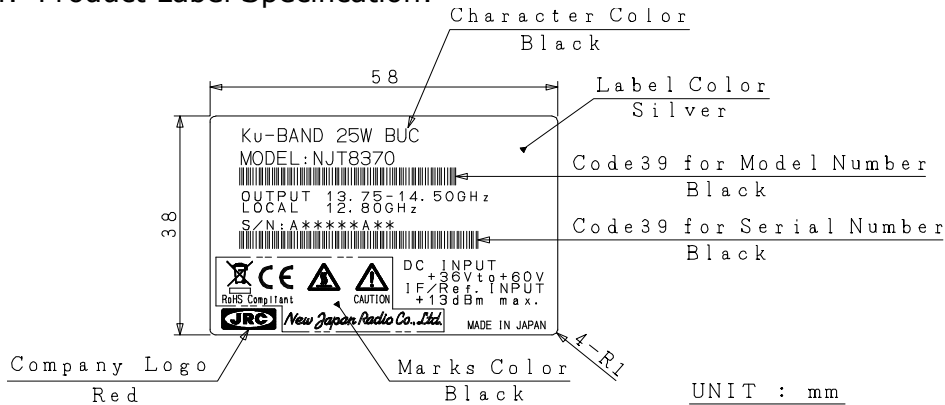

Marks Description



Indication of compliant with WEEE (Waste Electrical and Electronic Equipment) Directive



Caution for hot surface on the product



Caution for input voltage, input IF / Reference signal power

Definition of Serial Number

Serial Number (OSSSSRYM) - ALPHANUMERIC (9 characters)

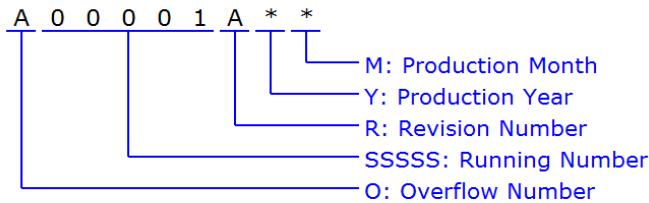

O: Overflow Number - ALPHABET (1 character)

"A" to "Z", e.g.: A99999 ⇒ B00001

SSSS: Running Number - NUMBER (5 digits)

"00001" to "99999"

R: Revision Number - ALPHABET (1 character)

"A" to "Z"

Y: Production Year - NUMBER (1 digit)

Calendar Number, e.g.: 2009: 9, 2010: 0, 2011: 1, 2012: 2 ····

M: Production Month - ALPHANUMERIC (1character)

"1" to "9", "X" as October, "Y" as November, "Z" as December

M&C Option for Ku-band GaN 25W BUC: NJT8370

Appendix) Specifications of Monitor & Control

Rev. 4.0
July 13, 2016

1. Interface Specifications

1-1. FSK Communication M&C

- (1) Physical Interface IF Connector: N-type or F-type, female
Combine with IF signal and 10MHz Reference signal
- (2) Transmitter Outputs
- a. Frequency 650 kHz $\pm 5\%$
 - b. FSK deviation ± 60 kHz nom. (+60 kHz mark)
 - c. Deviation tolerance ± 50 kHz min. / ± 70 kHz max.
 - d. Output Level -10 dBm nom.
 - e. Output impedance 50 Ω
 - f. Start Tone 710 kHz (mark) / 10ms min
- (3) Receiver Inputs
- a. Locking range ± 32.5 kHz
 - b. Input impedance 50 Ω
 - c. Input Sensitivity -15 dBm min.

1-2. RS-232C Interface M&C

- (1) Physical Interface MS Connector: P/N PT02E-14-12P (025)
Pin Assignment:



- Pin A: N.C.**
- Pin B: N.C.**
- Pin C: N.C.**
- Pin D: N.C.**
- Pin E: GND COMMON (RS-232C)**
- Pin F: N.C.**
- Pin G: RS-232C Tx D***
- Pin H: RS-232C Rx D***
- Pin J: DC Power (+) / Prime**
- Pin K: DC Power (-) / Return;
GND COMMON (RS-232C)**
- Pin L: N.C.**
- Pin M: N.C.**

- (2) Transmitter Outputs
- a. Output Voltage Swing ± 5 V min. / ± 5.4 V typ.
 - b. Output Resistance 300 Ω min. / 10 M Ω typ.
- (3) Receiver Inputs
- a. Input Voltage Range ± 15 V
 - b. Input Threshold low +0.6 V min.
 - c. Input Threshold High +2.4 V max
 - d. Input Resistance 7 k Ω max

2. Transmission Protocol

- a. Operation Mode Binary
- b. Transfer Rate 9600 bit/s
- c. Data Format 1 start bit, 8 data bits, 1 stop bit
No Parity

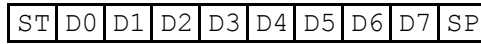

Transmit \longrightarrow

(The least significant bit (LSB) is sent first.)

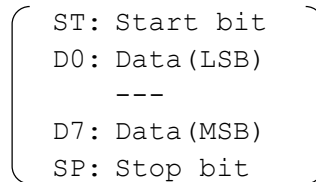

- d. Maximum Response Time 50 ms
- e. Message Rate 1 every 20 ms

3. Packet Format

- a. Data Packet Length 7 Bytes
- b. Byte Configuration

Byte	Command (IDU to BUC)	Response (BUC to IDU)
1st	BUC Address (*1)	BUC Address (*2)
2nd	Command	Data Byte 1
3rd	Data Byte 1	Data Byte 2
4th	Data Byte 2	Data Byte 3
5th	Data Byte 3	Data Byte 4
6th	Data Byte 4	Data Byte 5
7th	Check Sum (*3)	Check Sum (*3)

*1: Initial setting of a BUC address is 0x01.
 *2: Responder address is shifted left by 4 bits.
 *3: Algebraic sum of bytes 1 through 6.
 *Note: Spare bytes are always filled with 0xAA (10101010).

4. Command & Response Message Structure

The BUC status is stored to internal EEPROM.

The last BUC state is stored to internal EEPROM, so when the BUC is re-turned DC power on again, the state is reproduced last BUC condition.

4-1. Command Message Structure (IDU to BUC)

a. Request Status

This command can acquire output power level, alarm status, BUC class, and temperature etc.

Byte	Name	Description	Value
1	Address	BUC Address	0x01 (to 0x0F)
2	Command	Request Status	0x01
3	Data Byte 1	Not used	0xAA
4	Data Byte 2	Not used	0xAA
5	Data Byte 3	Not used	0xAA
6	Data Byte 4	Not used	0xAA
7	Checksum	Algebraic sum of bytes 1 - 6	

ex)

01	01	AA	AA	AA	AA	CHK
----	----	----	----	----	----	-----

b. Set Transmit On/Off State

This command can set a state of transmit on and transmit off.

Byte	Name	Description	Value
1	Address	BUC Address	0x01 (to 0x0F)
2	Command	Tx On/Off	0x02
3	Data Byte 1	Tx Control	Off:0x00/On:0x01
4	Data Byte 2	Not used	0xAA
5	Data Byte 3	Not used	0xAA
6	Data Byte 4	Not used	0xAA
7	Checksum	Algebraic sum of bytes 1 - 6	

ex)

01	02	01	AA	AA	AA	CHK
----	----	----	----	----	----	-----

c. Set Attenuator

This command can set the step attenuator with 0.5 dB step in the BUC.

Byte	Name	Description	Value
1	Address	BUC Address	0x01 (to 0x0F)
2	Command	Set Attenuator	0x05
3	Data Byte 1	Attenuator Selection 1 or 2	Att.1 0x01 Att.2 0x02 *1
4	Data Byte 2	Setting Att. in 10dB digit	0x00 or 0x01 *2
5	Data Byte 3	Setting Att. in 1dB digit	0x00 to 0x09 *2
6	Data Byte 4	Setting Att. bit in 0.5dB digit	0x00 or 0x05 *2
7	Checksum	Algebraic sum of bytes 1 - 6	

ex)

01	05	01	01	02	05	CHK
----	----	----	----	----	----	-----

*1: Att.1 is available, Att.2 is not available.

*2: Dynamic range and step size of the step attenuator: 15.5dB in 0.5dB step

ex) 12.5dB : Data byte 2 is 0x01
Data byte 3 is 0x02
Data byte 4 is 0x05

d. Get Attenuator

This command can check the step attenuator setting value in the BUC.

Byte	Name	Description	Value
1	Address	BUC Address	0x01 (to 0x0F)
2	Command	Get Attenuator	0x06
3	Data Byte 1	Attenuator Selection 1 or 2	Att.1 0x01 Att.2 0x02 *1
4	Data Byte 2	Not used	0xAA
5	Data Byte 3	Not used	0xAA
6	Data Byte 4	Not used	0xAA
7	Checksum	Algebraic sum of bytes 1 - 6	

ex)

01	06	01	AA	AA	AA	CHK
----	----	----	----	----	----	-----

*1: Att.1 is available, Att.2 is not available.

4-2. Response Message Structure (BUC to IDU)

a. Request Status

Byte	Name	Description	Value
1	Address	BUC Address shifted left by 4	0x10 (to 0xF0)
2	Level Byte 1	MS byte of Tx Output Power	*1
3	Level Byte 2	LS byte of Tx Output Power	*1
4	Temperature	Temperature in deg. C	*2
5	Status Byte 1	Bit 0: Temperature Out-of-Range	1:Fail , 0:Normal *3
		Bit 1: PLL Out-of-Lock	1:Fail , 0:Normal *3
		Bit 2: Checksum Error	1:Error , 0:Normal *3
		Bit 3: Tx Status	1:Tx On , 0:Tx Off *3
		Bits 4 thru 7: BUC Power Class	0x1 to 0xA *3
6	Status Byte 2	Bits 0 - 3: Not used	Fixed 0xA
		Bits 4 - 7: Software Version	0x0 to 0xF
7	Checksum	Algebraic sum of bytes 1 - 6	

ex)

10	10	FE	D8	88	1A	CHK
----	----	----	----	----	----	-----

*1: Data Field Definition for Tx Output Power

Output power is the number which changed hexadecimal data into the decimal number and was divided by 100.

ex) Output Power Data Output Power
 Level Byte 1 is 0x10
 Level Byte 2 is 0xFE } 0x10FE → +43.50 dBm

*2: Data Field Definition for Temperature

Temperature data is from -128°C to +127°C in two's complement (1°C step).

ex) Temperature Data
 Byte of Temperature is 0xD8 → 11011000 = -40 °C
 Byte of Temperature is 0xFF → 11111111 = -1 °C
 Byte of Temperature is 0x40 → 01000000 = 64 °C

*3: Data Field Definition for Status Byte 1

ex) Status Byte 1 is 0x88

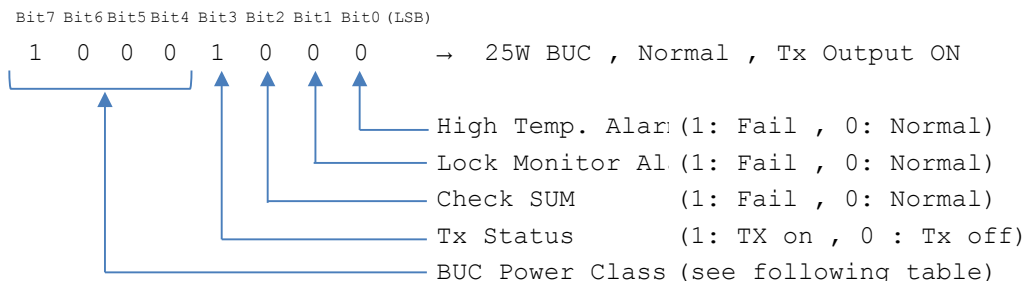

BUC Power Class table

Value	0x1	0x2	0x3	0x4	0x5	0x6	0x7	0x8	0x9	0xA
Power	2W	4W	5W	8W	10W	16W	20W	25W	40W	60W

*4: Data Field Definition for Status Byte 2

ex) Status Byte 2 is 0x1A → Firmware Version Ver.1

b. Set Transmit On/Off State

i) In case of FSK Communication M&C

The BUC responds the same message as 'Request Status' after the BUC set the transmit on/off state in accordance with the command message

ex)

10	10	FE	D8	88	1A	CHK
----	----	----	----	----	----	-----

ii) In case of RS-232C Interface M&C

Byte	Name	Description	Value
1	Address	BUC Address shifted left by 4	0x10 (to 0xF0)
2	Command	Tx On/Off	0x02
3	Data Byte 1	Tx Control	Off:0x00/On:0x01
4	Data Byte 2	Not used	0xAA
5	Data Byte 3	Not used	0xAA
6	Data Byte 4	Not used	0xAA
7	Checksum	Algebraic sum of bytes 1 - 6	

ex)

10	02	01	AA	AA	AA	CHK
----	----	----	----	----	----	-----

c. Set Attenuator

Byte	Name	Description	Value
1	Address	BUC Address shifted left by 4	0x10 (to 0xF0)
2	Command	Set Attenuator	0x05
3	Data Byte 1	Attenuator Selection 1or 2	Att.1 0x01 Att.2 0x02 *1
4	Data Byte 2	Set Att. bit in 10 dB digit	0x00 or 0x01
5	Data Byte 3	Set Att. bit in 1 dB digit	0x00 to 0x09
6	Data Byte 4	Set Att. bit in 0.5 dB digit	0x00 or 0x05
7	Checksum	Algebraic sum of bytes 1 - 6	

ex)

01	05	01	01	02	05	CHK
----	----	----	----	----	----	-----

*1: Att.1 is available, Att.2 is not available.

d. Get Attenuator

Byte	Name	Description	Value
1	Address	BUC Address shifted left by 4	0x10 (to 0xF0)
2	Command	Get Attenuator	0x06
3	Data Byte 1	Attenuator Selection 1or 2	Att.1 0x01 Att.2 0x02 *1
4	Data Byte 2	Set Att. bit in 10 dB digit	0x00 or 0x01
5	Data Byte 3	Set Att. bit in 1 dB digit	0x00 to 0x09
6	Data Byte 4	Set Att. bit in 0.5 dB digit	0x00 or 0x05
7	Checksum	Algebraic sum of bytes 1 - 6	

ex)

01	06	01	01	02	05	CHK
----	----	----	----	----	----	-----

*1: Att.1 is available, Att.2 is not available.