

## SM-WB100 / 100 Cup Electric Coffee Maker



- Brews 100 cups ( 19L ) in less than 70 minutes
- Contemporary styling
- 2-way, non-drip spigot with locking feature
- Higher clearance spigot accommodates larger cups
- Dual, high-limit thermostat protects against overheating
- Double-wall stainless steel construction
- Stainless steel components for easy cleaning
- Twist-to-secure cover with stay-cool handles
- Brew-view gauge with internal water level markings
- Indicator lights show Brewing and Ready / Keep Warm
- Removable stainless steel filter & stem;  
No additional filter required



Dimensions (WxDxH)	14.5"x15"x20.25"
Electrical	120V, 1500W, 60HZ, NEMA 5-15P Plug
Net weight (kg)	4.4
Gross weight (kg)	5.5

Specifications subject to change without notice.

**1-year limited warranty**

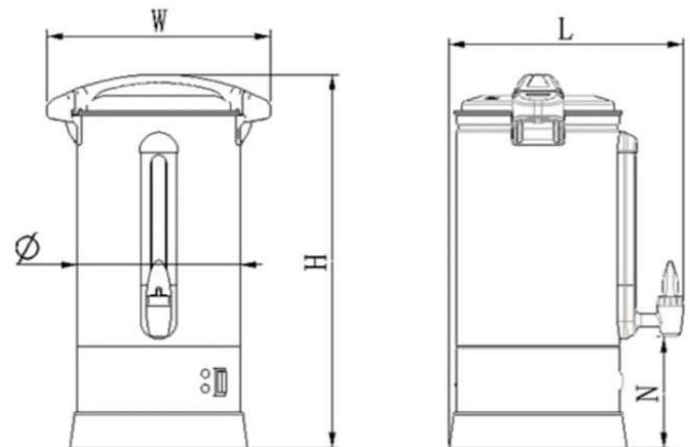

Φ MM	W (MM)	H (MM)	L (MM)	N (MM)
290	370	515	385	160