

## 60" Double Door Undercounter Freezer

### CABINET CONSTRUCTION

Heavy duty construction includes a 304 type stainless steel interior and a 430 type stainless steel exterior, resulting in strength, durability, and an attractive, sleek appearance.

Foamed-in-place CFC- and HCFC-free polyurethane insulation enhances the structural strength of the cabinet and helps increase energy efficiency.

One-piece rear grill is easily removed for cleaning and servicing. 2 doors feature easy-to-use recessed handles for quick interior access. Doors stay open past 90° for easy loading, but will self-close under 90° to save energy.

### REFRIGERATION SYSTEM

Environmentally safe R290 refrigerant. Rear-mounted condensing unit positioned for easy maintenance.

### SHELVING

2 white epoxy-coated steel shelves included. Each accommodate up to 90 lb.

### MODEL FEATURES

Copper evaporator coil eliminates the potential of corrosion.

Interior wall-mounted thermometer for easy temperature monitoring.

Preprogrammed digital controller features auto-defrost function.

- **Stainless steel interior and exterior, aluminum back.** Option of bright white aluminum interior available.
- **Refrigeration system** keeps food at safe temperatures between -8°F and 0°F (-22°C to -18°C).
- **Self-Closing doors** with 90 degree stay-open feature.
- **Shelves:** Adjustable heavy-duty PVC coated shelves.
- **Electronic control system** makes it easy to adjust temperature set point and defrost frequency.
- **Preinstalled heavy-duty casters with brakes.**
- **Removable installation board** makes it easy to access condenser coil for cleaning and service.
- **These units use HYDRO-CARBON R290 refrigerant,** which is environmentally friendly and more efficient than R134a/R404a refrigerant.



SML-UC60F



# SUN MING ENTERPRISES LTD.

## TECHNICAL DATA

### Dimensions

Exterior Dimensions	60½"W x 29½"D x 35½"H
Interior Dimensions	55⅝"W x 22⅞"D x 23½"H
Working Height	59½"
Net Volume	15 cu. ft.
Net Weight	254 lb.
Gross Weight	323 lb.
Packaging Dimensions	63"W x 32¼"D x 38½"H
BTU (BTU/HR)	743

### Construction

Exterior Material	Type 430 Stainless Steel
Interior Material	Type 304 Stainless Steel
Insulation Material	Foamed-in-Place Polyurethane
Shelf Size	(2) 26¾" x 17"
Shelf Material	Epoxy-Coated Steel
Shelf Load Capacity	90 lb.

### Cooling

Temperature Range	(-8)°F - 0°F
Refrigerant	R290
Max. Ambient Temperature	100°F
Defrosting	Automatic
Temperature Controller	Digital
Horsepower	1/2+

### Electrical

Voltage	115
Amps	6.36
Hz	60
Phase	1
Plug Type	NEMA 5-15P
Electrical Cord Length	84"

## PLAN VIEW

FRONT VIEW

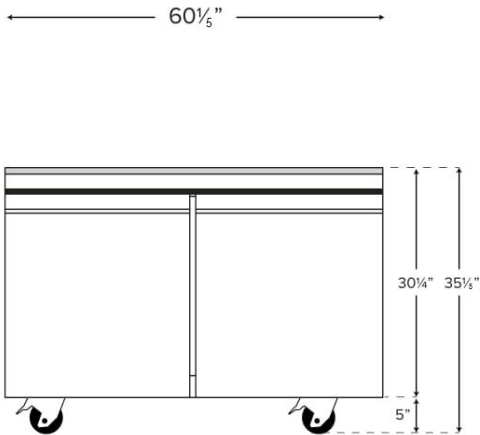

SIDE VIEW

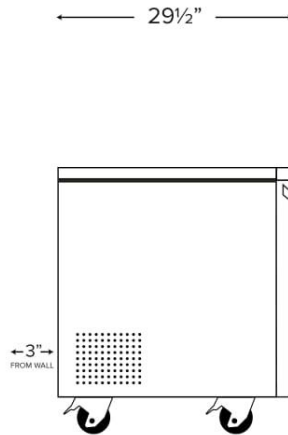

TOP VIEW

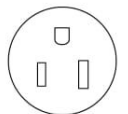
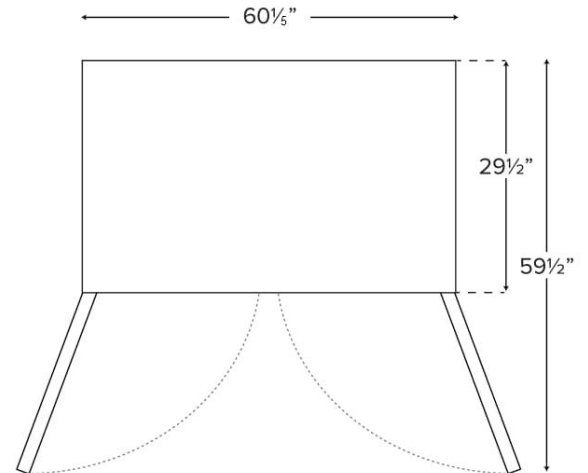

NEMA 5-15P