

## 27" Undercounter Refrigerator

### CABINET CONSTRUCTION

Heavy duty construction includes a 304 type stainless steel interior and a 430 type stainless steel exterior, resulting in strength, durability, and an attractive, sleek appearance.

Foamed-in-place CFC- and HCFC-free polyurethane insulation enhances the structural strength of the cabinet and helps increase energy efficiency.

One-piece rear grill is easily removed for cleaning and servicing.

1 door feature easy-to-use recessed handles for quick interior access. Door stay open past 90° for easy loading, but will self-close under 90° to save energy.

### REFRIGERATION SYSTEM

Environmentally safe R290 refrigerant. Rear-mounted condensing unit positioned for easy maintenance.

### SHELVING

1 white epoxy-coated steel shelf included. Each accommodate up to 90 lb.

### MODEL FEATURES

Copper evaporator coil eliminates the potential of corrosion.

Interior wall-mounted thermometer for easy temperature monitoring.

Preprogrammed digital controller features auto-defrost function.

### SPECIAL FEATURES

- Eco-friendly R290 hydrocarbon refrigerant
- Strong and sleek 430 type stainless steel exterior
- 304 type stainless steel interior maintains temperatures from 33°F - 40°F
- One epoxy-coated steel shelf accommodates up to 90 lb. each
- Foamed-in-place polyurethane insulation
- Easy-to-read digital temperature controller and auto-defrost function
- Casters for easy mobility
- 115V; 1/6 hp



**SML-UC27R**



## TECHNICAL DATA

### Dimensions

Exterior Dimensions	27"W x 29½"D x 35½"H
Interior Dimensions	22¼"W x 22⅞"D x 23½"H
Working Height	35¼"
Net Volume	6.3 cu. ft.
Net Weight	159 lb.
Gross Weight	202 lb.
Packaging Dimensions	29¾"W x 32¼"D x 38½"H

### Construction

Exterior Material	Type 430 Stainless Steel
Interior Material	Type 304 Stainless Steel
Insulation Material	Foamed-in -place polyurethane
Shelf Size	(1) 21⅞"x17¾"
Shelf Material	Epoxy-coated steel
Shelf Load Capacity	90 lb.

### Cooling

Temperature Range	33°F - 40°F
Refrigerant	R290
Max. Ambient Temperature	100°F
Defrosting	Automatic
Temperature Controller	Digital
Horsepower	1/6

### Electrical

Voltage	115
Amps	1.9
Hz	60
Phase	1
Plug Type	NEMA 5-15P
Electrical Cord Length	84"

## PLAN VIEW

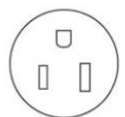
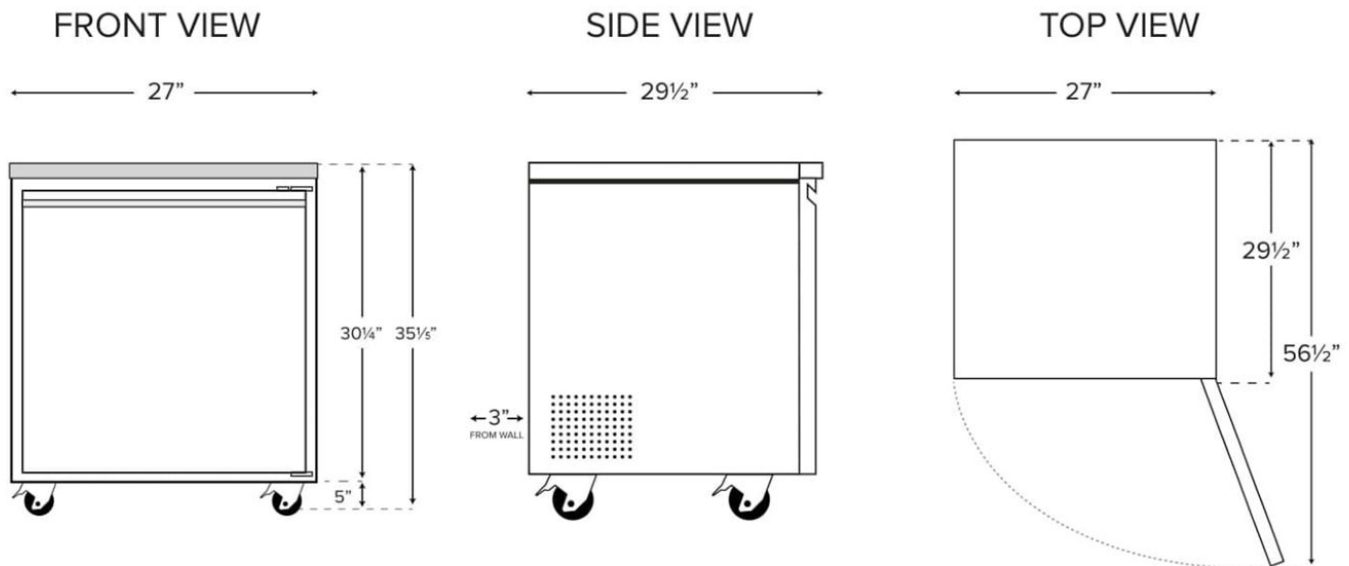

NEMA 5-15P