

60" Two Door Sandwich/Salad Prep Table



SML-S60-16

FEATURES

- ▶ Standard top model
- ▶ Stainless steel exterior and interior
- ▶ Refrigeration system keeps food at safe temperatures
- ▶ Self-closing doors with 90 degree stay-open feature
- ▶ Adjustable heavy-duty PVC coated shelves
- ▶ Cutting boards and clear pans
- ▶ Recessed door handle
- ▶ Electronic control system
- ▶ Preinstalled heavy-duty casters with brakes
- ▶ Removable installation board
- ▶ Hydro-Carbon R290 refrigerant



TECHNICAL DATA

DIMENSIONS

Exterior Dimensions	60.5"L x 29.5"D x 42.3"H
Interior Dimensions	56.3"L x 23.8"D x 23.5"H
Packaging Dimensions	64.5"L x 33.8"D x 45.5"H
Cutting Board Dimensions	60.1"L x 10"D x 3/4"H
Working Height	35.3"
Overall Height (Open Cover)	47.25"
Net Volume	15 cu. ft.
Unit Weight	352 lb.
Shipping Weight	418 lb.

ELECTRICAL

Voltage	115
Hertz	60
Phase	1
Amps	4.8
Plug Type	NEMA 5-15P
Power Cord Length	96"

COOLING

Temperature Range	33°F to 41°F
Refrigerant	R290
Max. Ambient Temp	90°F
Defrosting	Automatic
Temperature Controller	Digital
Horsepower	1/4+

CONSTRUCTION

Top Unit Type	Standard
Exterior Material	Stainless Steel
Interior Material	Stainless Steel
Insulation Material	Foamed-in-Place Polyurethane
Shelf Size	(2) Qty: 27.6"W x 17"D
Shelf Load Capacity	90 lb.
Shelf Material	Epoxy Coated Steel
Adjustable Shelf	Yes
Pan Capacity	(16) x 1/6 or (8) x 1/3
Interior Light	L.E.D
Mobility Wheels/Casters	(4) Qty: 2 with brakes, 2 without

DIAGRAM



NEMA 5-15P

FRONT VIEW

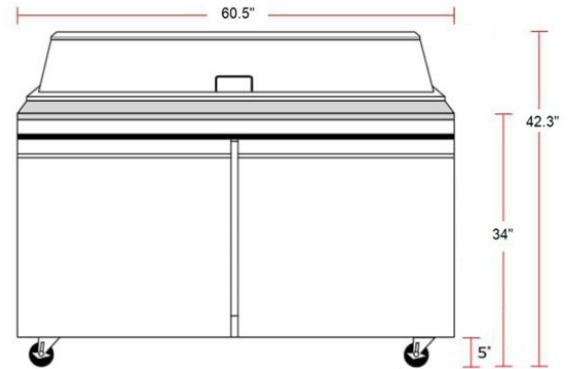

SIDE VIEW

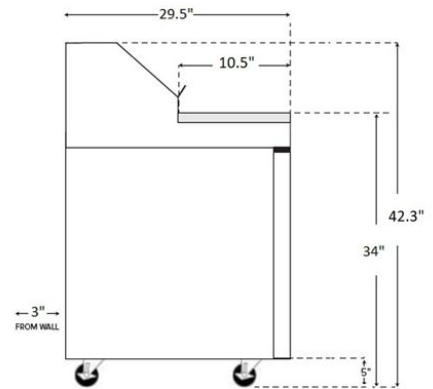

TOP VIEW

