

## Twin Tank 4 Burners Gas Fryer

### Features

- Twin tank
- 4 burner
- Stainless steel front and door
- Large cold zone to trap food particles
- 1-1/4" full port drain valve for fast and complete oil draining
- 6" adjustable stainless steel legs standard, casters optional
- Tank is fully peened for smoother welds & easy cleaning
- Drain pipe holder attached to inside door
- Twin nickel plated baskets



Model# SML-DF4DT-NG

### Specifications

- Gas type: NG
- 120,000 BTU/Hour
- Millivolt(snap action) thermostat, 200°F~400°F
- Oil capacity: 70-75lbs
- 3/4" NPT gas connection
- NG gas 4" W.C.
- Legs adjustable from 6" - 7 1/2" total leg height
- Dimensions: 21" W x 34.8" D x 45.6" H
- Shipping dimensions: 22.5" W x 36.3" D x 33.5" H
- Shipping weight: 220lbs

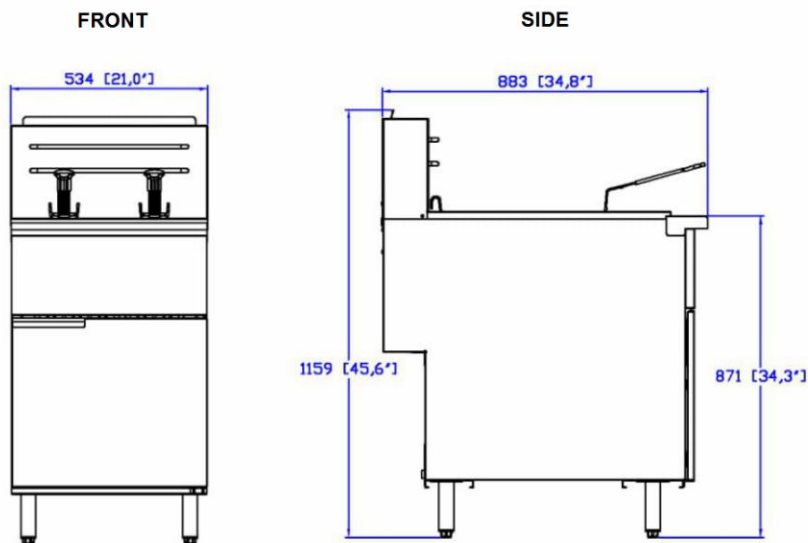

\*\*\*Specifications subject to change without notice