

## Bakery Display Case



**SMC-DC60S**

### Standard Features

- Brilliant internal LED lighting each shelf and bottom
- 2 adjustable glass shelves
- Digital temperature control and display
- Double tempered glass
- 4 Castors with 2 brakes
- Ventilated cooling system
- Automatic defrost

### Specification

- Capacity-gross: 510L/18.0c.f.
- Temperature range: 2-8°C (35.6-46.4°F)
- Rated input power: 480w
- Refrigerant: R290
- Climate Type: 4
- N.W.: 175kg
- G.W.: 216kg
- Overall dimension: 1550×675×1220mm  
61×26.6×48inch
- Package dimension: 1590×735×1245mm  
62.6×30×49inch

### Front View

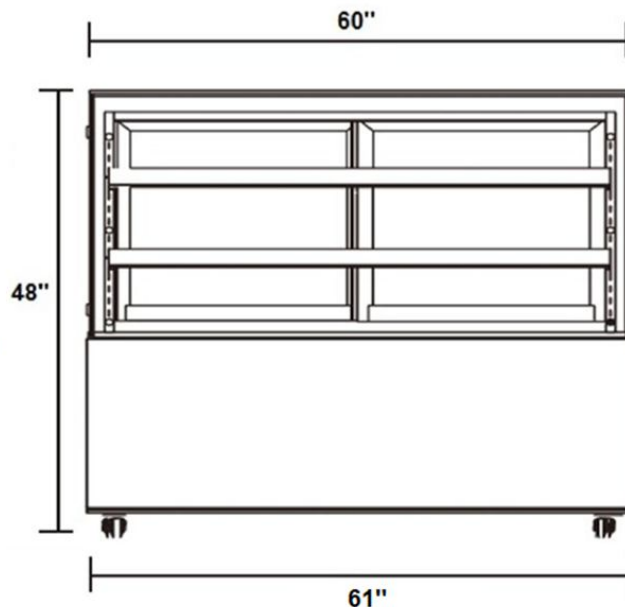

### Side View

