

Newtop Electric Commercial Water Boiler

Model No.: SM-WB-3K

FEATURES:

- Double layer 304 stainless steel
- The copper boiling water outlet
- Anti-scalding, hygienic, easy to clean
- Automatically enter water
- Space saving design – can be placed on the worktable
- Display water temperature
- You can choose left or right to enter the water
- Optional items: heightened base, water tray, etc.



SPECIFICATIONS

Product	Electric Commercial Water Boiler
Model No.	SM-WB-3K
Dimension	L400.5 x D283 x H824.3mm
Capacity	28L
Rated Voltage	220V / 60Hz / 1PH
Rated Power	3000w / 13.6A
Water Output	40-45 L/H
Water Tap	1
Water Pressure	0.1-0.4Mpa
Material	Stainless steel
Color	Silver

FRONT

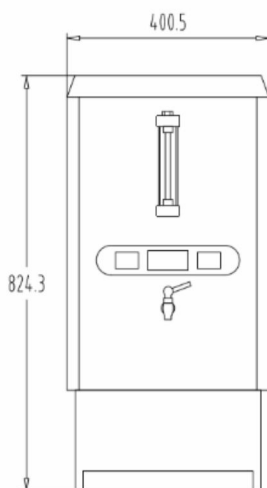

SIDE

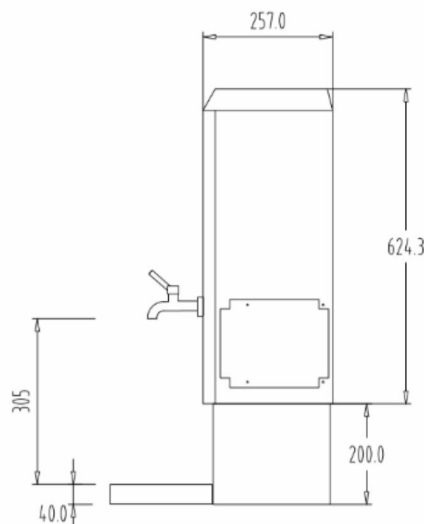

TOP

