

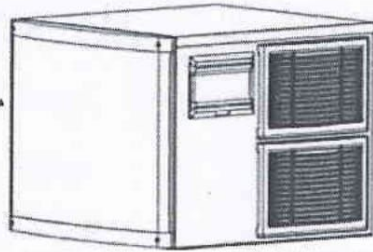

**SM-IM-500**

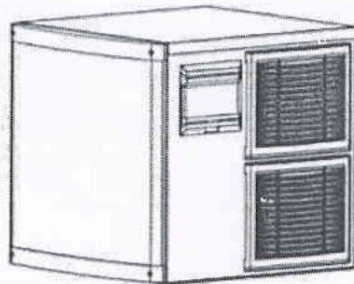

**SM-IM-350**



## **Modular Type Ice Machine Installation and Maintenance Instructions**

Please read the attached instructions carefully before installation

# Content

## I. The Installation of Ice Machine

1.Unpacking Note	3
2.Environmental Requirements	3
3.Water supply installation	3
4.Power Supply Requirements	4

## II. The Use of Ice Machine

1.Checking before Operation	4
2.Familiarize with the Operation Panel	5
3.Operating process	6
4.Other Special Stop Conditions	7

## III. Maintenance and Common Faults

1.Maintenance	7
2.Common Faults and Removal	8
3.Conditions Not Covered By Warranty	8

## IV. Attachment

1.List of Attachments	8
-----------------------	---

## V. Annex

1.Error Codes	9
2.Circuit Diagrams	9

Note: We reserve the rights to amend any part of the content in this manual without prior notifications.

# Modular Type Ice Machine Installation and Maintenance Instructions

## I. Ice Machine Installation

### 1. Unpacking Note

- Check the machine model before unpacking.
- Check whether the outer package is intact before unpacking.
- Check whether the machine is in good condition, or whether the accessories are complete after unpacking.

### 2. Environmental Requirements

- Indoor use only. Running the machine below freezing point is strictly prohibited.
- Environment temperature: Maximum temperature  $< 43^{\circ}\text{C}$ , minimum temperature  $> 3^{\circ}\text{C}$ .
- Peripheral spacing: Proper spacing must be observed. (spacing can be reduced accordingly with water cooling machine). Please refer to the table below:

Machine	Spacing in cm
Side	15
Back	20
Front	30

- Machine level placement: Level the machine in place. (It can be adjusted through the adjustable foot at the bottom of the machine.)

### 3. Water Supply Installation

- The water used for the ice making must be in accordance with the standards of local drinking water.
- The water used for the ice making may be connected to a filtration device first. (Depending on the local water quality)
- **It is forbidden to connect the ice machine with hot water.** ⚠
- Please refer to the water inlet and drain pipe layout as following:

Water Temperature ( $^{\circ}\text{C}$ )	Ice Making Water Pressure (Mpa)	Cooling Water Pressure (Mpa)	Inlet Pipe Diameter (mm)	Drain Pipe Diameter (mm)
$>0.6$	$>0.13$	$>0.59$	$>9.5$ (3/8")	$>15.8$ (5/8")
$<32$	$<0.55$	$<1.17$		Drop per meter $>3\text{cm}$

**The installation of drain pipe must observe the following principles**

**(Please refer to the diagram below):** ⚠

1. Any point in the middle of drain pipe shall not be higher than the outfall.
2. Any point in the middle of drain pipe shall not be higher than outlet.

## ● Installation Diagram (for reference only):

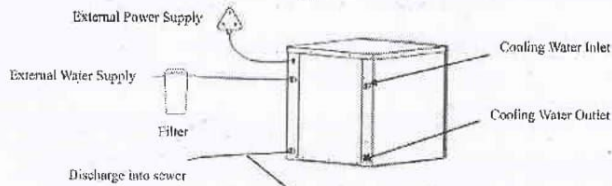

Note:

- a) The inlet and outlet of cooling water are only applicable to the water cooling machine.
- b) The outer filter is optional.

### Drain Pipe Installation Attention

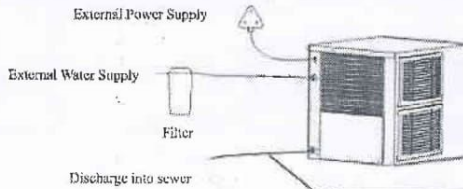

Note:

- The outer filter is optional.

### Drain Pipe Installation Attention



## 4. Power Supply Requirements

- The voltage, frequency and capacity of power supply provided is consistent with that marked on the machine nameplate.
- **The earth terminal of the power supply, socket or plug must be connected to the external grounding steadily!** ⚠
- The power supply wire provided etc. shall all be in accordance with the standards of the local country or region.
- The power supply voltage fluctuation shall not exceed  $\pm 10\%$  of the rated voltage.

## II. The Use of Ice Machine

### 1. Checking Before Operation

- Whether all the temporary fixed tapes in the ice machine has been removed!
- Whether all the accessories or other items in the ice machine has been taken out!
- Whether the ice machine is appropriately leveled!
- Whether all the water pipes are correctly connected!
- Whether the plug is connected to the power supply steadily!
- **Whether the machine grounding is connected to external grounding steadily!** ⚠
- To confirm that the power supply's voltage frequency and others are consistent with the machine nameplate!
- To confirm that the environment temperature and water temperature is with the scope mentioned!

## 2. Familiarize with the Operation Panel

- With voice panel:

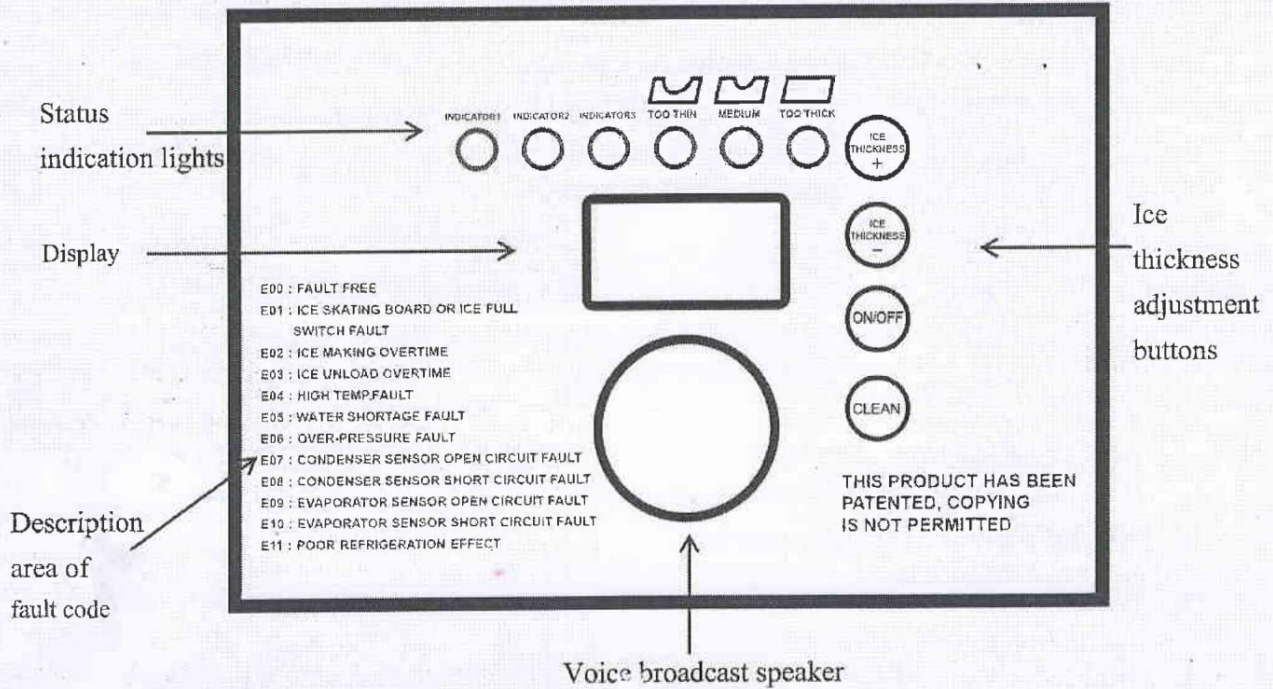

- Without voice panel:

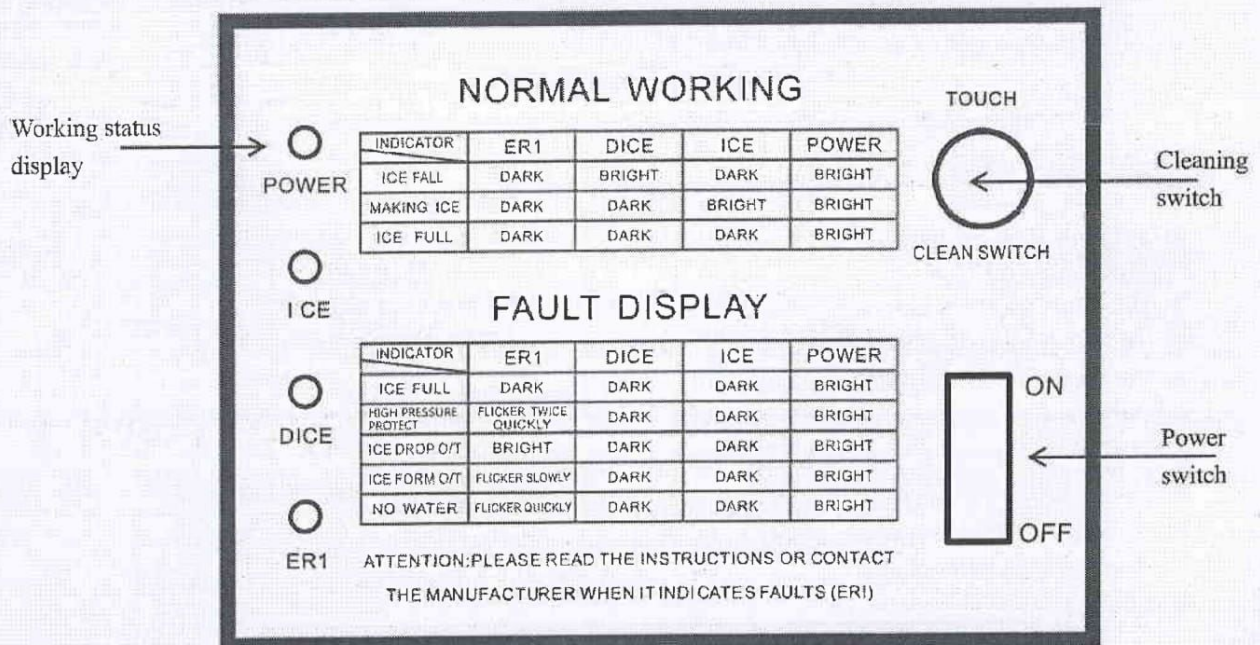

### 3. Operating Process

- **Start up:** Clicking the button (switch) on the panel after connected to the power and water supply correctly, the machine will on. During the whole operating process, it will work automatically.(Note: Please turn off the power supply in case of thunderstorm or long time not in use.)
- **Pre-cooling:** After power on, the water inlet valve will turn on automatically, the evaporator pre-cools for 30 seconds before the water pump starts up, meanwhile the compressor starts, the water pump stops running, the water inlet valve continues to take in water till the specified level (that is to say water floating ball switch stops water inlet).
- **Ice making:** After pre-cooling for 30 seconds, the water pump starts up, continuous water flows smoothly and ice comes into being gradually in ice tray of the evaporator.
- **Ice falling:** After reaching the stipulated ice making time, the water pump shuts down, the defrost valve powers on and open, and hot air enters into the evaporator, at the same time the drain valve closes after 30 seconds. The water inlet valve open, the whole sheet of ice will slide from the evaporator into the storage refrigerator after defrosting for 1~2 minutes. **During the process of ice falling, hands should be away from the storage refrigerator to avoid being hit by it ! ⚠**
- **Shutdown:** When the machine runs, clicking the button (switch) on the panel and the machine stops working.
- **Automatic Stop When Ice is Full:** In the running, with the accumulation of ice in the ice bin, it will reach to a certain height and block other ice fall down. Eventually the full of ice result in sliding board cannot be rebounded and reset. After machine detected it for a few time (30 seconds or so) and confirmed ice bin is full of ice, the machine will stop working automatically. Until removed full of ice, the sliding board will be rebounded and reset again, then machine will work automatically again.
- **Ice thickness adjustment:** There are two methods to adjust the ice thickness. Please choose one according to the machine.  
**Method I,** In the process of ice making, the adjusting screw on the ice thickness detector can be rotated left or right according to the actual condition and the attached adjustment instruction labeling if the ice thickness isn't satisfactory, and tightens the screw after the adjustment is completed. Note: The adjustment shall be limited to a circle each time.

Ice Thickness Adjusting Screw

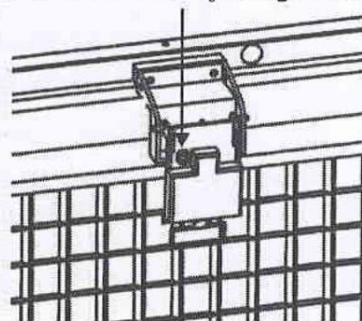

**Method II,** In ice making process, if you are not satisfied with ice thickness please adjust it through clicking the button on the touch panel ( increase ice thickness +, reduce ice thickness -)

Note: ice making time will extend or shorten one minute for every click.

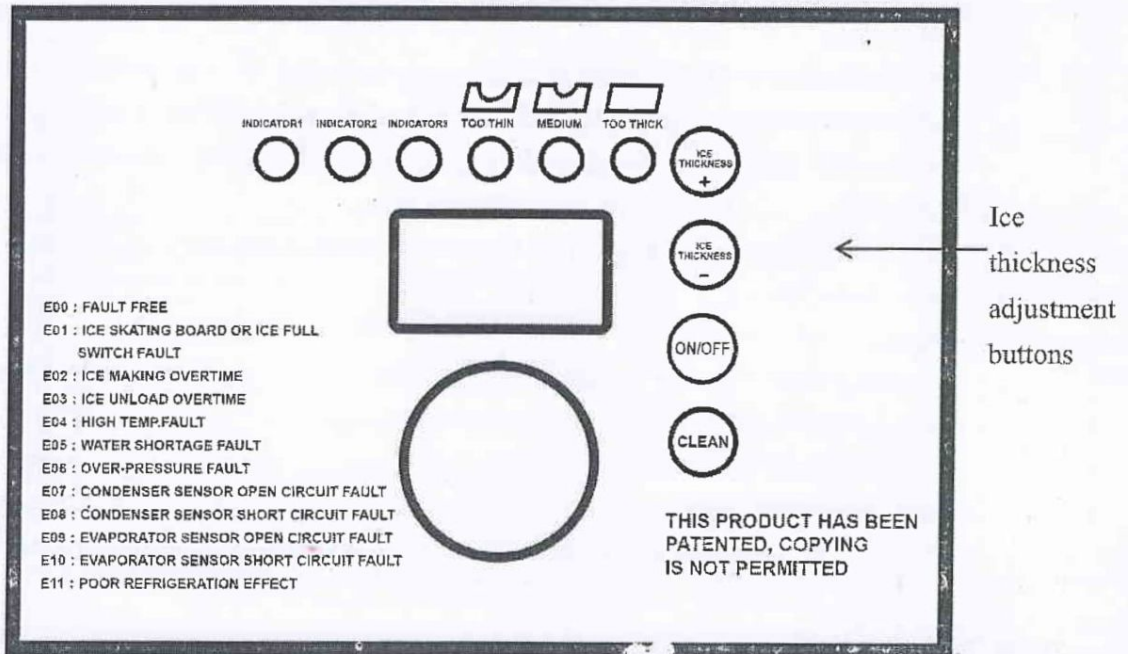

### 4. Other Special Stop Conditions

- There is no ice falling in three times consecutive cycles, this series of machine stops automatically.
- Environmental temperatures exceeds the prescribed temperature, this series of machine stops automatically.
- No condensed water in water cooling machine, this series of machine stops automatically.

## III. Maintenance and Common Faults

### 1. Maintenance:

- **Before maintenance and repair, the power must be cut off!** ⚠
- Maintenance and repair shall be handled by qualified professionals only.
- Please read this manual in detail before maintenance and repair.
- The manufacturer isn't responsible for the consequences of poor water quality and wrong operation.
- Clear the dust on the surface of machine regularly.
- Clean the filter net (only applicable to air cooling machine) regularly, As shown by picture:

## Ice Machine Installation and Maintenance Instructions

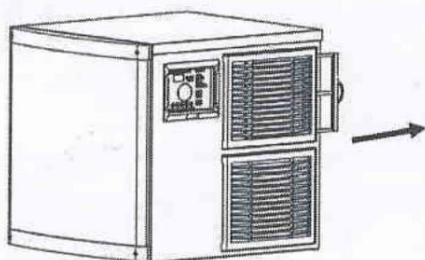

Take out all the filter nets along the direction of arrow on both sides, and put back the net into the ventilation window after dusting by soft brush.

- Clean the cooling fin regularly at least at every 6 months. Please use the soft brush to work in up-and-down lightly. Don't swipe left-and-right for fear of damaging the cooling fin and influencing the heat dissipation effect.

### 2.Common Faults and Removal:

Fault Phenomenon	The possible causes of troubleshooting	Check and eliminate
Ice Machine not starting up	No power supply	Power switch, power wire
Automatic stop after starting the ice machine for 3 minutes	High pressure protection	High ambient temperature, dirty condenser , high voltage switch,air cooled motor
Ice machine can only make ice once whenever it starts	Ice full	Ice sliding board
Ice cannot fall	Ice machine is dirty, the ambient temperature is low	Clean, ambient temperature up to requirement.
Ice is too thin or incomplete	Tank water level is too low, inlet valve doesn't work, water pressure is not enough 、 waterway is not smooth	Check water level, water inlet valve, water pressure and pipeline
Ice making is too slow	Condenser is dirty, high ambient temperature and poor ventilation	Clean the filter and condenser, keep specific spacing around the machine

### 3.Conditions Not Covered By Warranty:

The following conditions are not with the scope of ice machine warranty:

- A. Normal maintenance, adjustment and cleaning.
- B. Modify ice machine without authorization or use the non-original parts without prior written permission from manufacturer.
- C. Damage incurred due to improper installation, power supply, water supply and drainage, etc.



## Ice Machine Installation and Maintenance Instructions

---

D. Additional labor fee due to holidays, overtime, etc., travel expenses during the travel

and reimbursement, etc. The extra expenses caused by inconvenience of maintenance.

E. Damage parts caused by misuse, abuse or negligence.

F. Damage or malfunction incurred caused by failure to follow the installation cleaning or maintenance of the ice machine in the manual.

G. Other external damages not mentioned above.

### IV. Attachment

Please refer to the attached list in detail.

### V. Annex

#### 1. Error Codes:

Code	Annotation	Machine Action
E00	No fault	Operating
E01	Ice sliding board fault	Protection Shutdown
E02	Overtime ice making fault	Protection Shutdown
E03	Overtime ice-shedding fault	Protection shutdown
E04	High temperature fault (voice announcement pressure beyond limit)	Protection shutdown
E05	Water shortage fault	Protection shutdown
E06	Excess of pressure limit fault	Protection shutdown
E07	Condensation sensor open circuit fault, display once every 5 seconds	Non stop
E08	Condensation sensor short circuit fault, display once every 5 seconds	Non stop
E09	Evaporator Sensor open circuit fault, display once every 5 seconds	Do not stop
E10	Evaporator sensor short circuit fault, display once every 5 seconds	Do not stop
E11	Pool refrigeration effect	Protective stop

#### 2. Circuit Diagrams

