

ADAPTIVTM MOTORCYCLE ACCESSORY MOUNT

RESERVOIR MOUNT INSTALLATION

ADAPTIVTM
TECHNOLOGIES

Contents

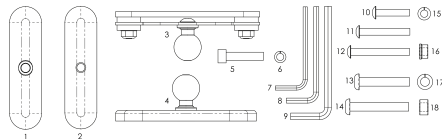

Item No.	Name	Quantity
1	Link Left	1
2	Link Right	1
3	Mounting Plate	1
4	Base Plate	1
5	Positioning Screw	1
6	Positioning Lock Washer	1
7	2.5mm Hex Key	1
8	3mm Hex Key	1
9	5/32" Hex Key	1
10	M4 x 20mm Screw	4
11	M4 x 30mm Screw	4
12	M4 x 35mm Screw	4
13	M5 x 30mm Screw	4
14	M5 x 35mm Screw	4
15	M4 Lock Washer	4
16	M4 Spacer	4
17	M5 Lock Washer	4
18	M5 Spacer	4

This mount is designed for attachment to the brake reservoir on many motorcycles.



Warning: Installation of the mount should be performed by a qualified technician. Improper installation may interfere with the safety and proper operation of the product and/or vehicle.

1. Place the motorcycle on a center stand.
2. Remove the factory installed screws that fasten the cover to the brake reservoir. These screws will not be reused.
3. If the brake reservoir has 4 screws, use the appropriate Hex Key to fasten the Base Plate to the brake reservoir cover with the appropriate length M4 Screws, M4 Lock Washers, and M4 Spacers, or M5 Screws, M5 Lock Washers, and M5 Spacers as shown in Figure 1.

Note: Do not remove or discard the bike's brake reservoir cover! The mount is designed to sit on top of the cover.

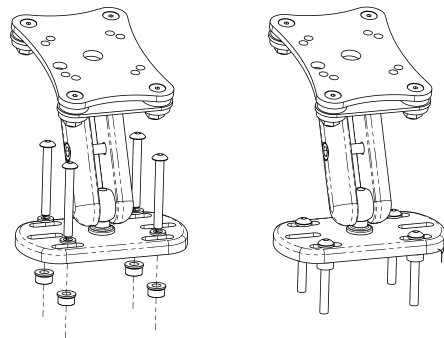

Figure 1

4. If the brake reservoir has 2 screws, use the appropriate Hex Key to fasten the Base Plate to the brake reservoir cover with the appropriate length M4 Screws, M4 Lock Washers, and M4 Spacers, or M5 Screws, M5 Lock Washers, and M5 Spacers as shown in Figure 2.

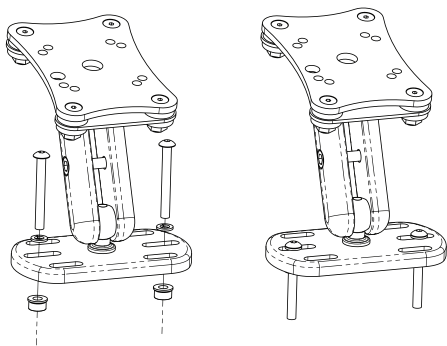

Figure 2

5. Using the 5/32" Hex Key, loosen the *Positioning Screw* as shown in Figure 3.

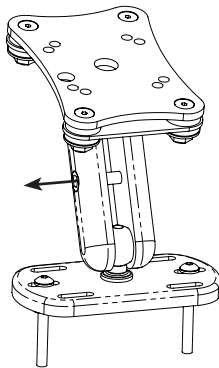
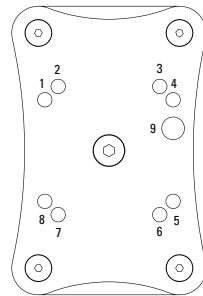

Figure 3

6. Fasten the accessory device or cradle to the top of the *Mounting Plate* utilizing appropriate hardware. The eight "AMPS" pattern holes (1-8) will accommodate #8 or M4 screws. The larger hole (9) will accommodate a 1/4" or M6 screw. Alternatively, double sided adhesive tape or hook and loop fastener may be used.



Mounting Plate Holes

7. Adjust the mount to the desired position and tighten the *Positioning Screw* to lock the assembly in place.



Warning: Verify that the position of the mount and accessory will not interfere with proper operation of the vehicle.



Warning: Make sure all screws and nuts are securely tightened before each ride so that the assembly will not move during use.

Adaptiv Technologies

1639 11th Street
Suite 156
Santa Monica, CA 90404

www.AdaptivTech.com

866-ADAPTIV
(866-232-7848)
646-722-0253