

TPX™

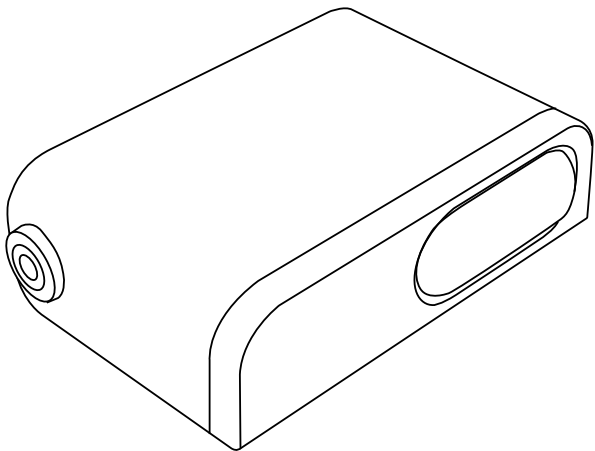

**MOTORCYCLE
LASER JAMMER AND
PARKING SENSOR SYSTEM
MANUAL**

ADAPTIV™
TECHNOLOGIES

You may register this product online at
www.AdaptivTech.com

TABLE OF CONTENTS

Introduction	4
Safety Warning	5
Package Contents	5
Product Overview	6
Using the <i>TPX™ System</i>	8
Installation	8
Mounting the <i>Transponder</i>	8
Mounting the <i>Visual Alert</i>	9
Mounting the <i>Control Switch</i>	10
Wiring the <i>TPX™ System</i>	11
General	11
Power	11
Transponder	12
Visual Alert	12
Control Switch	12
AUX	12
USB	12
Operation	12
Power	12
Function Selection	13
Auto Shut–Off	13
Alert Off	13
Volume and Brightness Control	13
Parking Sensor Function	14
Software Updates	14
Troubleshooting	14
Maintenance and Care	15
Service	15
Warranty Service	15
Non–Warranty Service	16
Warranty	16
Specifications	17
Accessories	18

INTRODUCTION

Dear *TPX™ Motorcycle Laser Jammer and Parking Sensor System* Owner,

Congratulations on your purchase of the re-designed *TPX™ Motorcycle Laser Jammer and Parking Sensor System*! This System is the result of years of research and development by the motorcycle-minded engineers who started the company.

This *System* is not cluttered with unnecessary features. Its simple and straight forward design allows you to focus on your ride, while enjoying peace-of-mind protection.

Our goal is to provide you with the highest quality products designed specifically for motorcycles. Enjoy your new *TPX™ Laser Jammer and Parking Sensor System*. Enjoy your ride, and ride safe.

Sincerely
Adaptive Technologies

SAFETY WARNING

When using the *TPX™ Laser Jammer and Parking Sensor System* and its associated components, it is the sole responsibility of the operator to install all components properly and to ensure that they will not interfere with safe operation of the vehicle, nor will they cause any personal injury or damage in the event of an accident. The operator should operate the vehicle in a safe manner while using the system and its components. The operator should not use the system if it is distracting, unsafe, or dangerous to do so.



Warning: Using this product is not a license to speed! Always ride safely and obey traffic laws.



Warning: It is your responsibility to be familiar with all laws applicable to the possession and use of laser jammers in your locality. The manufacturer and retailer assume no responsibility for any use or application of this product in violation of any applicable law. Please check your state and local laws and regulations before installing this product.



Warning: Do not look directly into the transponder! The *Transponder* emits a powerful infrared beam of light which is not visible, but can cause eye damage from prolonged exposure!

PACKAGE CONTENTS

- TPX™ Laser Jammer and Parking Sensor Transponder (2)
- TPX™ Laser Jammer and Parking Sensor Interface Box (1)
- TPX™ Laser Jammer and Parking Sensor Control Switch (1)
- TPX™ Laser Jammer and Parking Sensor Control Switch Mounting Tape (1)
- TPX™ Visual Alert (1)
- TPX™ Visual Alert Mounting Tape (1)
- TPX™ Laser Jammer and Parking Sensor Bracket (2)
- TPX™ Laser Jammer and Parking Sensor Bracket Mounting Tape (2)
- TPX™ Laser Jammer and Parking Sensor Bracket Screw (4)
- TPX™ Laser Jammer and Parking Sensor Bracket Washer (4)
- TPX™ Laser Jammer and Parking Sensor Screw (4)
- Spirit Level (1)
- Cable Tie (8)
- Female T-Tap Connector (1)
- USB Extension Cable (1)
- Product Manual (1)
- Product Registration Form (1)

PRODUCT OVERVIEW

The *TPX™ Laser Jammer and Parking Sensor System* is designed specifically for motorcycle use. It is to be used as a standalone system.

When the *Transponder* detects an incoming laser signal, it automatically jams the laser gun to prevent a speed reading. The rider is notified of the signal with the flashing *Visual Alert*. An audio output jack is provided for optional integration with a sound/communication system. Brightness, volume, and power are managed with the *Control Switch*.

The *TPX™ Laser Jammer and Parking Sensor System* is waterproof, vibration proof, and easy to use. It is powered through the bike's 12V electrical system and can be upgraded with the latest software releases via the internet.

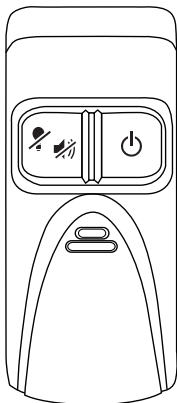

Figure 1a

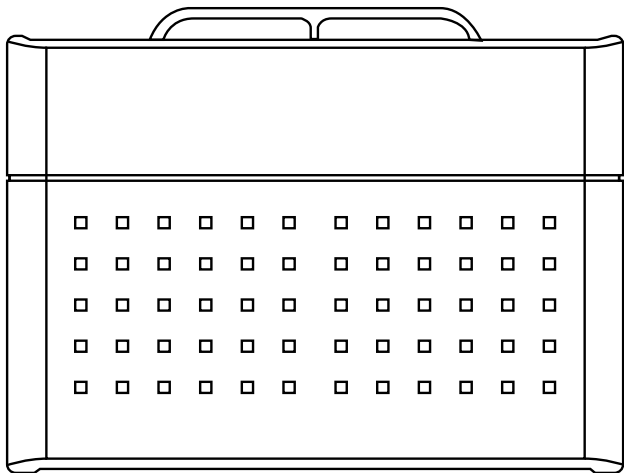

Figure 1b

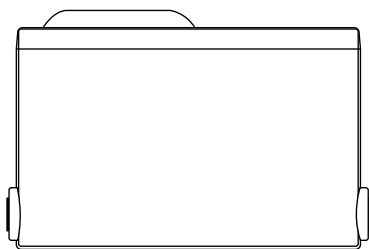

Figure 1c

USING THE TPX™ MOTORCYCLE LASER JAMMER AND PARKING SENSOR SYSTEM

INSTALLATION



Warning: Installation of the *TPX™ Motorcycle Laser Jammer and Parking Sensor System* should be performed by a qualified technician. Improper installation may interfere with the safety and proper operation of the product and/or vehicle.

Mouting the Transponder

The *TPX™ Laser Jammer and Parking Sensor System* includes two *Transponders* to be mounted on the front of the bike. An additional *Transponder* for rear protection is available separately.

Use the included *Bracket Screws* and *Brackets* to loosely secure the *Transponders* as shown in Figure 2.



Warning: Use only the *Bracket Screws* to secure the *Brackets* to the *Transponder*. Any other screws will damage the *Transponder* and void the warranty.

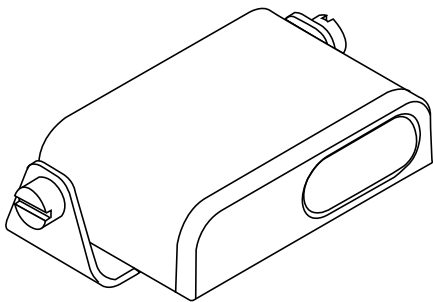

Figure 2

Choose an appropriate location on the front of the motorcycle to mount the *Transponders*. The ideal location is usually on the fairing, under the front headlight. The *Transponders* will need to be mounted as parallel to the road

as possible with a clear line of sight straight ahead. Both *Transponders* should also be as close to the headlight as possible and as far apart from each other as possible.

With the *Spirit Level*, adjust the *Transponder* until it is parallel to the ground and mount the *Transponders* with *Bracket Screws* and *Bracket Washers*, *Mounting Tapes*, or other custom mounting method. It is recommended to have someone sit on the motorcycle to simulate the motorcycle's actual riding position while this adjustment is being performed.



Warning: The *Jammer Bracket Screws*, *Jammer Bracket Washers*, and *Jammer Bracket Mounting Tapes* are included for your convenience. They will work on most motorcycles. However, all motorcycles are different and it is your responsibility to determine the best method of securing the system to your bike. Adaptiv Technologies, LLC is not responsible for any vehicle damage resulting from improper mounting.

Since laser is rarely used to target vehicles from behind, one *Transponder* should be sufficient for the rear of the vehicle. Additional *Transponder* and *Transponder License Plate Bracket* are available separately.

Mounting the Visual Alert

The *Visual Alert* is designed to be mounted on any part of the motorcycle that is easily be seen by the rider. The LEDs should be pointed directly at the rider's face.

There are two mounting options for the *Visual Alert*.

Option 1: Using Double-Sided Adhesive Tape

- Determine an appropriate location for mounting the *Visual Alert*. The surface directly above the gauges is an ideal location on many motorcycles.
- Clean the bottom surface of the *Visual Alert* and the chosen mounting surface on the motorcycle with alcohol or mild soap and water. Rinse with water to remove all traces of soap.

- Once the surfaces are clean and dry, remove one liner of the *Visual Alert Mounting Tape* and apply to the bottom surface of the *Visual Alert*.
- Remove the other liner of the *Visual Alert Mounting Tape* and apply the *Visual Alert* to the chosen mounting surface on the motorcycle using firm pressure.
- Allow mounted assembly to sit overnight while tape increases bond strength.

Option 2: Using Cable Ties

- Determine an appropriate location for mounting the *Visual Alert*.
- Fasten with *Cable Ties* as shown in Figure 3.

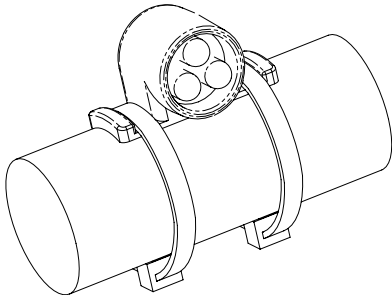

Figure 3

Mounting the Control Switch

- Determine an appropriate location for mounting the *Control Switch*. The best location is one that is easily accessible while riding.
- Clean the chosen mounting surface on the motorcycle with alcohol or mild soap and water. Rinse with water to remove all traces of soap.
- Once the surface is clean and dry, remove the liner of the *Control Switch Mounting Tape* and apply the *Control Switch* to the chosen mounting surface on the motorcycle with firm pressure.
- Allow to sit overnight while tape increases bond strength.

WIRING THE TPX™ LASER JAMMER AND PARKING SENSOR SYSTEM

General

Wire the system according to the wiring diagram in Figure 4.
Secure all loose wires with included *Cable Ties*.

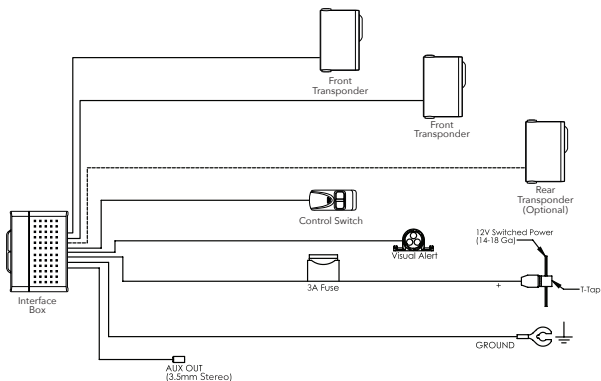

Figure 4

Power

To provide power to the *System*, connect the red (+) terminal cable to a 12V, 14Ga-16Ga switched power wire with the provided Female T-Tap Connector. Connect the black (Ground) cable to a ground.



Warning: If the *System* is not connected to a 12V power source that is switched off when the ignition is turned off, it will continue to draw a small amount of power and could drain the bike's battery and/or function improperly.



The *TPX™ Laser Jammer and Parking Sensor System* is designed to be powered by a switched 12V power source. If the motorcycle's power output is not 12V, a voltage adaptor is required.

Transponder

Connect the two *Transponders* to the connectors labeled “FR1” and “FR2” on the *Interface Box*.

If a third (optional) *Transponder* is used, connect it to the connector labeled “RE1” on the *Interface Box*.

Visual Alert

Connect the *Visual Alert* to the connector labeled “*Visual Alert*” on the *Interface Box*.

Control Switch

Connect the *Control Switch* to the connector labeled “*Switch*” on the *Interface Box*.

AUX

The connector labeled “AUX” on the *Interface Box* provides a stereo audio output signal. This audio signal can be utilized with any number of communication systems. The connector is a 3.5mm female stereo jack. Contact your communication system manufacturer for appropriate adapter device.

USB

When upgrading the software, follow the instruction on our website and connect an USB Drive (not included) to the connector labeled “USB” on the *Interface Box* using the provided *USB Gender*.

OPERATION

When the *Transponder* detects an incoming laser signal, it instantly sends out a jamming signal to prevent a speed reading on the laser gun. The *Visual Alert* will notify you of this signal, as will an alarm signal through the AUX Out connector (if connected).

Power

Press and hold the  button for three seconds to turn the system on and off.

Function Selection

Press and hold the  button for one second to switch between *Parking Sensor* and *Laser Jammer* function. When the system is in *Parking Sensor* function the *Control Switch* light will be blue and when the system is in *Laser Jammer* function the *Control Switch* light will be in red.

Auto Shut-Off



The default setting of *TPX™ Laser Jammer and Parking Sensor System* has Auto Shut-Off feature activated, where the *System* will sense, alert, and jam any incoming laser signal for 3 seconds. After 3 seconds the *System* will shut itself off. This allows the laser gun to obtain a reading only AFTER you have had 3 seconds to check your speed. To turn the *System* back on, press and hold the  button for three seconds.

Pressing the  button momentarily will toggle between activating and deactivating Auto Shut-Off. A single flash on the *Control Switch* light and a single beep through the AUX port indicate Auto Shut-Off activation, a double flash on the *Control Switch* light and a double beep through the AUX port indicate Auto Shut-Off deactivation.

Alert Off

When the *TPXT™ Laser Jammer System* is jamming a laser signal, press the  button to mute and turn off the Visual Alert for the duration of the laser signal.

Volume and Brightness Control

Press and hold the  button for one second to toggle between Volume and Brightness adjustment modes. The Volume adjustment mode is indicated with a single flash on the *Control Switch* light and a single beep through the AUX port and Brightness adjustment mode is indicated with a double flash and a double beep through the AUX port. Press the  button momentarily to scroll through the four levels of Volume and Brightness levels. Scroll to the desired Volume or Brightness level and the *Control Switch* will flash multiple times indicating the desired Volume or Brightness level has been set.



Warning: The flashing LEDs of the *Visual Alert* can be extremely bright, especially at night time. It can be distracting and dangerous if you are not familiar the brightness level. Before riding with the *Visual Alert*, especially at night, take the time to familiarize yourself with the system in a safe, controlled setting.

Parking Sensor Function

In *Parking Sensor Function*, the *System* will alert if there is an object within 3 feet in front of the *Transponder*.

Software Updates

Software updates are available online. When an update is available, connect a flash USB drive (not included) and follow the instructions online.

TROUBLESHOOTING

If your *TPX™ Laser Jammer and Parking Sensor System* is not operating properly, please refer to the following guide:

Problem	Possible Causes	Possible Solutions
<i>System</i> will not turn on	<i>System</i> not properly connected to power source Vehicle not turned on <i>System</i> power off	Check fuse, replace with a 3A fuse if necessary Check power connections Turn vehicle on Press and hold  button for three seconds with vehicle turned on
<i>System</i> does not operate properly	Software update interrupted	Go to www.AdaptivTech.com/ support to download the latest software
<i>System</i> drains motorcycle's battery over time	<i>System</i> is not connected to switched power source	Connect power to switched power source that turns on/off with ignition.
<i>System</i> resets when vehicle goes over a bump	Poor electrical connection	Check power connections
<i>System</i> did not register a signal when driving past a police vehicle	Police laser is not turned on Police laser is not pointed directly at your vehicle Non-laser detection methods are being used	Slow down and remain cautious

MAINTENANCE AND CARE

- The *TPX™ Laser Jammer and Parking Sensor System* is weather resistant. It is designed to withstand temporary exposure to moisture, such as rain or fog. However, it should not be exposed to moisture for a prolonged period of time. Do not hose the system down. Do not submerge the *System* as this will void the warranty.
- Clean the *System* components with a damp lint-free cloth only. Do not use any chemicals as they may attack the plastic.
- Dry the *System* components with a lint-free cloth after it has been exposed to moisture.
- Keep the *Transponder* lens clean to maintain optimal function. The *Transponder* strength may decrease if the lens becomes scratched.

SERVICE

Warranty Service

If you believe that your *TPX™ Laser Jammer and Parking Sensor System* is not functioning properly:

1. Review the Troubleshooting section.
2. If your problem is not resolved after reviewing the Troubleshooting section, have your serial number ready and call us at 646-722-0253. We will try to resolve your problem over the phone.
3. If your system needs to be returned for repair, we will provide you with a Return Merchandise Authorization (RMA) Number and a shipping address. Write the RMA Number on the outside of the shipping box. Include the following items in your shipment:
 - a. Items needing repair.
 - b. Copy of sales receipt (originals cannot be returned).
 - c. Your name, phone number, address, and email address (we promise not to spam).

All shipment must be sent prepaid by way of a traceable carrier, such as UPS, FedEx, USPS Priority Mail with Tracking, etc., and should be insured. Adaptiv Technologies is not responsible for any loss or damage incurred during shipping.

Warranty service will only be honored for units purchased from authorized agents.

Repairs will not be performed on units without a readable serial number.

Please allow 4-8 weeks for the return of the system.

Non-Warranty Service

For all non-warranty service, follow the same procedure described in the Warranty Service section and include a non-refundable payment of \$150 for basic diagnostics and repair. Do not send cash. If there are any additional charges, we will notify you before performing the repair.

WARRANTY

Adaptiv Technologies, LLC warrants to the original purchaser that the *TPX™ Laser Jammer and Parking Sensor System* will be free of defects in workmanship and materials for a period of one year from the date of first consumer purchase. The *TPX™ Laser Jammer and Parking Sensor System* consists of the *Interface Box*, two *Transponders*, *Visual Alert*, the *Control Switch*, and the respective parts of each. Adaptiv Technologies will, at its option, repair or replace defective parts upon delivery to Adaptiv Technologies accompanied by the original sales receipt or other proof of first consumer purchase within the warranty period. You are responsible for all charges required to ship the product for warranty service, but the return charges will be at Adaptiv Technologies' expense if the product is repaired or replaced under warranty. This warranty gives you specific rights, and you may also have other rights which vary from state to state.

EXCLUSIONS: This limited warranty does not apply:

1. To any products sold separately (such as any mount assemblies);
2. To any defects caused by misuse, abuse, accidents, modifications, negligence, tampering, or unauthorized repair;

3. In any State or country or jurisdiction in which possession of laser jamming equipment is illegal;
4. If the serial number has been altered, defaced, or removed; or
5. To installation of the unit.

ALL IMPLIED WARRANTIES, INCLUDING IMPLIED WARRANTIES OF MERCHANTABILITY AND FITNESS FOR A PARTICULAR PURPOSE ARE LIMITED IN DURATION TO THE PERIOD OF THIS WARRANTY*.

* Some states do not allow limitations on the duration of implied warranties and/or do not allow the exclusion or limitation of incidental or consequential damages, so the above limitations may not apply to you.

SPECIFICATIONS

Classification:

1M Eye Safe Laser

Wavelength:

905 nanometers

Operating Temperature Range:

-20°C to +80°C (-4°F to +176°F)

Power Requirements:

12V DC

Fuse:

3A

PATENTS PENDING

ACCESSORIES

The following accessories and replacement parts are available for purchase. For more information, go to www.AdaptivTech.com or call us at 646-722-0253.

TPX™ Laser Jammer Transponder

TPX™ Laser Jammer License Plate Bracket

TPX™ Visual Alert

TPX™ Wireless Headset

TPX™ Motorcycle Radar and Laser Detector System and accessories

AdaptivMount™ Motorcycle Accessory Mounts

Adaptiv Technologies, LLC

www.AdaptivTech.com

646-722-0253