

ADAPTIVTM MOTORCYCLE ACCESSORY MOUNT

SPORTBIKE MOUNT TYPE D INSTALLATION

ADAPTIVTM
TECHNOLOGIES

CONTENTS

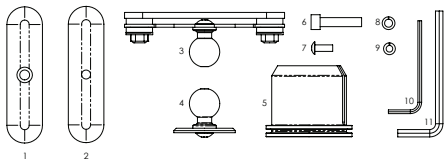

Item No.	Name	Quantity
1	Link Left	1
2	Link Right	1
3	Mounting Plate	1
4	Base Plate	1
5	Steering Stem Nut	1
6	Positioning Screw	1
7	Base Plate Screw	4
8	Positioning Lock Washer	1
9	Base Plate Screw Washer	4
10	5/64" Hex Key	1
11	5/32" Hex Key	1

This mount is designed for attachment to Ducati motorcycles.



Warning: Installation of the mount should be performed by a qualified technician. Improper installation may interfere with the safety and proper operation of the product and/or vehicle.

1. Place the motorcycle on a center stand.
2. Loosen the three Pinch Bolts that hold the Top Triple Tree onto the Forks and Steering Stem Nut.
3. Remove the top triple tree.
Note: Some models may require removal of the clip-ons.
4. Use the Ducati Steering Stem Nut Tool (available through most dealerships) to remove the stock Steering Stem Nut. The stock Steering Stem Nut will not be reused.
5. Use the 5/32" Hex Key to remove the *Positioning Screw* and disassemble the top portion of the mount as shown in Figure 1.

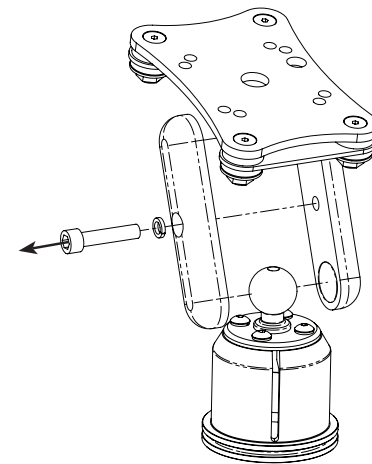

Figure 1

6. Use the $5/64$ " Hex Key to unfasten the *Base Plate* from the *Steering Stem Nut* as shown in Figure 2.

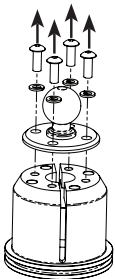

Figure 2

7. Using the Ducati Steering Stem Nut tool, screw the *Steering Stem Nut* onto the *Steering Stem Post*. Torque to manufacturer's specifications.
8. Replace the *Top Triple Clamp* and tighten the three *Pinch Bolts*.
9. Use the $5/64$ " Hex Key to fasten the *Base Plate* to the *Steering Stem Nut* with the *Base Plate Screws* and *Base Plate Washers* as shown in Figure 3.

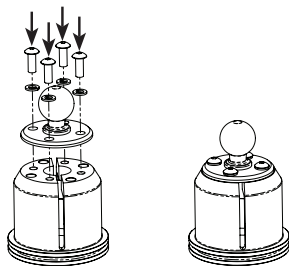

Figure 3

10. Using the $5/32$ " Hex Key, loosely reassemble the mount as shown in Figure 4.

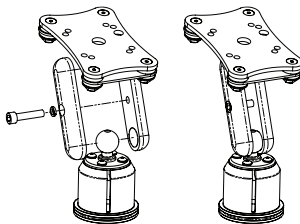
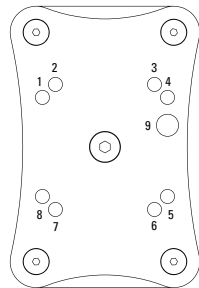

Figure 4

11. Fasten the accessory device or cradle to the top of the *Mounting Plate* utilizing appropriate hardware. The eight "AMPS" pattern holes (1-8) will accommodate #8 or M4 screws. The larger hole (9) will accommodate a $1/4$ " or M6 screw. Alternatively, double sided adhesive tape or hook and loop fastener may be used.



Mounting Plate Holes

12. Adjust the mount to the desired position and tighten the *Positioning Screw* to lock the assembly in place.



Warning: Verify that the position of the mount and accessory will not interfere with proper operation of the vehicle.



Warning: Make sure all screws and nuts are securely tightened before each ride so that the assembly will not move during use.

Adaptiv Technologies

1639 11th Street
Suite 156
Santa Monica, CA 90404

www.AdaptivTech.com

866-ADAPTIV
(866-232-7848)
646-722-0253