

# Samsung chip 3 Edge-lit High power LED module (12V) Sunflower Series USER GUIDE

## ELECTRICAL

Current dissipation : 700mA  
 Power Consumption : 8.4W  
 Quantity for maximum connection in serial : 6 modules  
 Operating power : DC 12V  
 Constant Current Driving system  
 Electronic dimming control supported

## THERMAL

Cooling : Aluminum heatsink & Ambient air  
 Maximum operating temperature : 50°C  
 Minimum operating temperature : -10°C  
 Maximum storage temperature : 60°C  
 Minimum storage temperature : -20°C



**IP65**

**42,500H LIFETIME**



## PRECAUTIONS

Use precautions to avoid damages to the product or injuries of users. Any actions against following contents will cause serious issues such as malfunction, electric shock, or burn.



USE DC12V ONLY



DO NOT USE AC INPUT



Do not cut or rejoin wires while product is connected with live power source



Avoid performing installation under rain or high humidity for outdoor use



Do not use the product under circumstances listed below

- High temperature spots over 60°C (140°F)
- Spots draw extreme moisture or dust
- Spots have corrosive gas or highly effected by electromagnetic field



Do not perform actions listed below

- Alter or modify
- Touch optical lens with sharp objects
- Put glue or silicon over the optical lens



Maximum driver quantity per serial connection is limited. Failure causes overload of current and damages to the product



Refer to 'WIRE THICKNESS' table to use proper wire thickness between SMPS and the first LED module  
 Failure will cause dimmed output



Cable length between SMPS and the first LED module is limited. Refer to 'CONNECTION WITH POWER SUPPLY' on page 2

## PREPARATION TOOLS REQUIRED

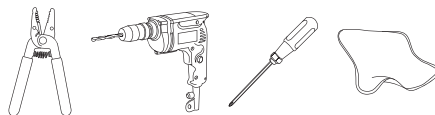

Wire Stripper, Drill, Screw Driver, Wiper

## SUPPLIES REQUIRED

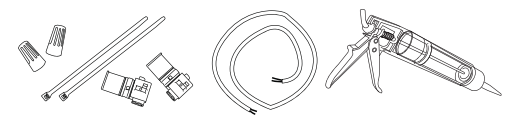

Wire Nuts, Cable Ties, IDC Connectors, VCTF(PLTC) Cable, (Optional : Silicon and Screws)

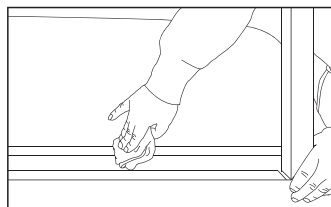

1. Clean moisture and dust inside

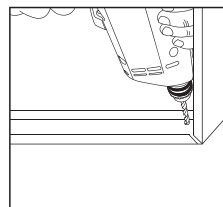

2. Make holes

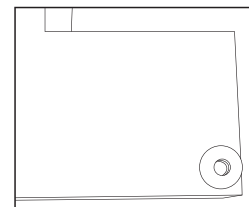

3. Use bushing to protect wires

1. Wipe out dust, water, and oil inside.
2. Make holes for wires from modules to SMPS.
3. Without bushins, wires will easily be cut and short-circuit will occur.  
 \*Use white paint inside the channels for better reflection

# Samsung chip 3 Edge-lit High power LED module (12V) Sunflower Series USER GUIDE

## INSTALLATION GUIDE 1. PLACEMENT AND FASTENING

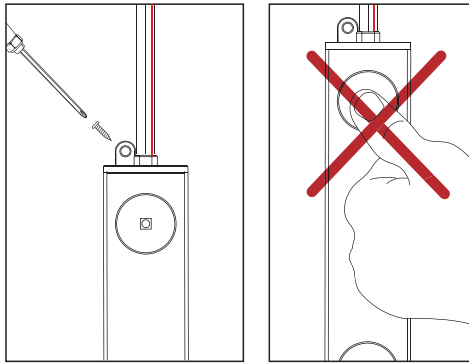

Using predetermined layout and LED placement from step of preparation.  
If desired, modules can be secured with screw



### CAUTION

When handling the module, avoid pressing down directly on the top of optic lens.

## 2. CAP ALL UNUSED WIRES

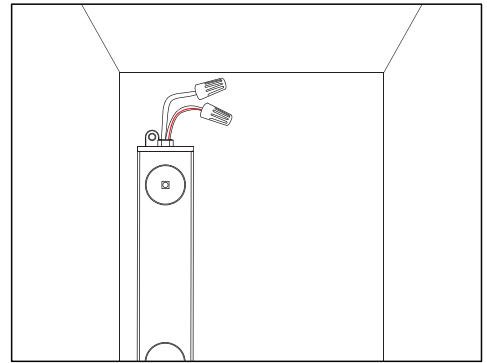

The strand of modules should not be looped to create a closed circuit.

## 3. CONNECTIONS

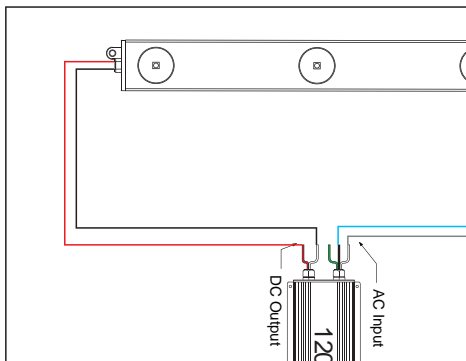

Using predetermined layout and LED placement from step of preparation, divide channels into sections, and distribute each section to corresponding power supplies



### WARNING

Before connect with power supplies, check polarity on every connections. All connections must be RED-TO-RED(+) and WHITE-TO-WHITE(-) Reverse polarity connections may damage the LEDs and power supplies and will void product warranty.

## 4. FIX MODULES PERMANENTLY ON : If desired, modules can be

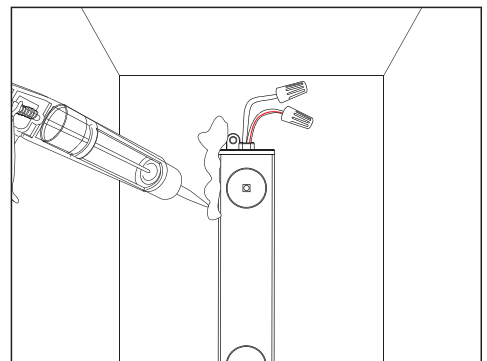

### SILIC

secured with silicon.  
Do not to put silicon on the top of the lens. AEHANTRANS C

# Samsung chip 3 Edge-lit High power LED module (12V) Sunflower Series USER GUIDE

## LAYOUT DENSITY GUIDELINES

Use recommended and identical length for pitch between each module to achieve optimum and uniform lighting output while maintaining lowest unit cost. Failure or misplacing will cause dimmed spots or uneven appearance of light on the surface.

### Single Sided Light box

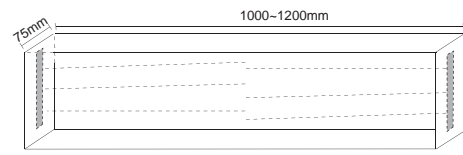
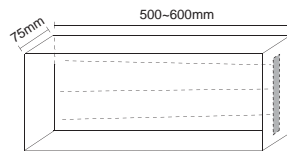

### Double sided Light box

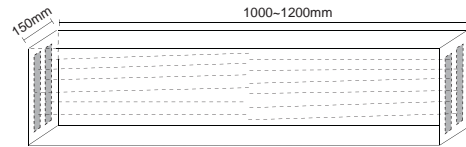
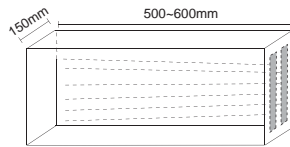

## WIRING GUIDE

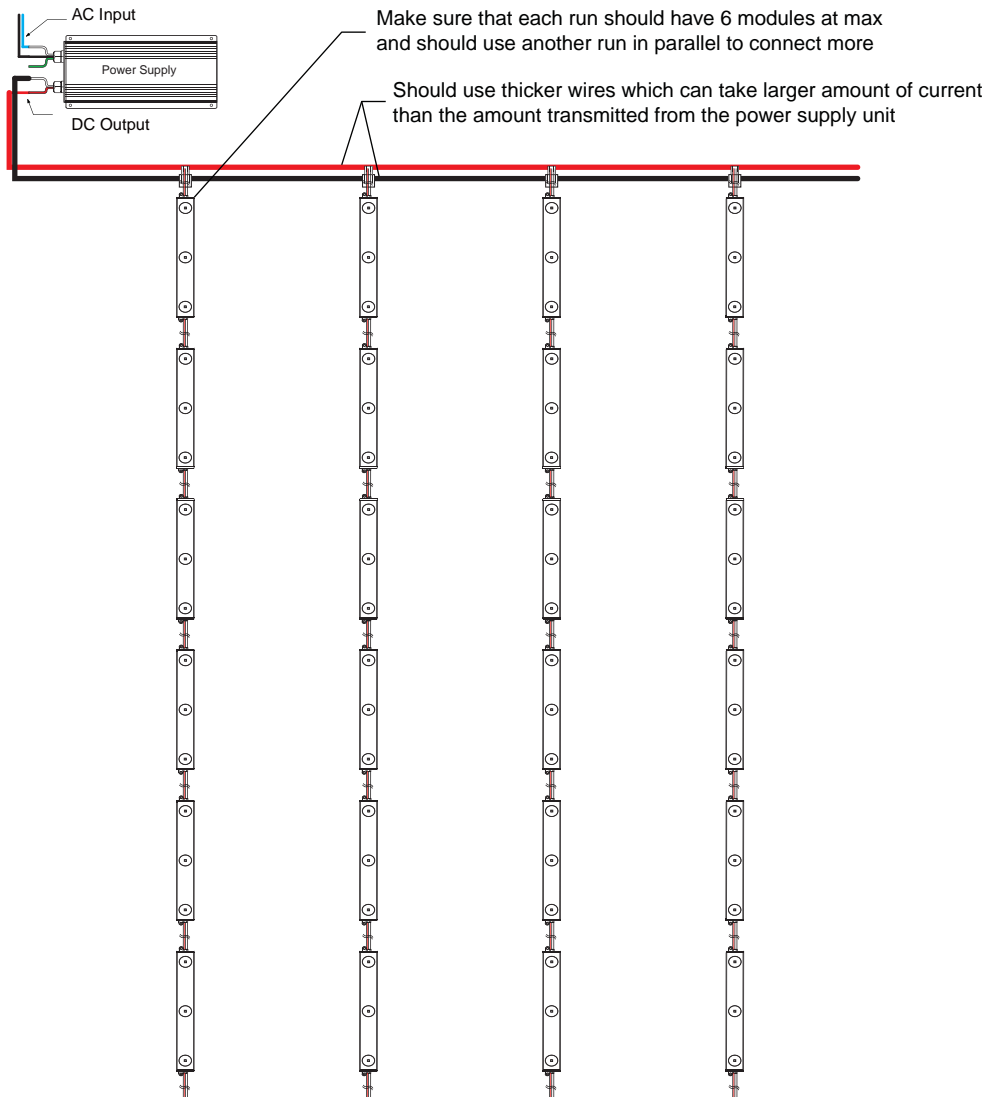

# Samsung chip 3 Edge-lit High power LED module (12V) Sunflower Series USER GUIDE

## TROUBLE SHOOTING

Entire sign or leg does not light after complete installation.	Check connection from power supply lead to first module. Make sure polarity of connections made at the power supply lead and any jumper wire is correct. Power supply outputs should be connected red-to-gray and white-to-white.
Still does not light.	Check output voltage of power supply using a voltmeter. The output voltage should be 12.0VDC $\pm$ 0.5VDC. If there is no output voltage, have a licensed electrician check input voltage. Make sure power supply is connected correctly and getting primary power. Probably AC input wire is connected to ground terminal of power supply. If power supply is connected properly and getting primary power and there is still no output voltage, try a different power supply.
Still does not light.	If power supply is getting primary power and the modules do not light, there may be a short in the secondary wiring. Check all connections and cap all loose wires.
Beginning of a leg lights, but the entire leg does not light or lights intermittently.	The primary cause of a portion of a S-LED leg not lighting or lighting intermittently is a bad connection or reverse polarity connection between the modules that light and the modules that don't light. Check this connection.
One module does not light, but all others in the leg light.	The WIDE L-165 is designed so if one module fails, it will not cause the entire sign or leg to go out. If one module does not light, but all others in the leg do, replace this module with
All modules light, but some of them are dimmed.	Check each run has no more than maximum number of modules. Also ensure that type of the extension wire from SMPS to the first module is correct. If wires are not thick enough to transmit current from SMPS, this will cause voltage drop and will dim the modules at
Dark spots or dimmed spots occur.	Channel depth is too low, or center distance between modules is too far. Refer to 'LAYOUT DENSITY GUIDELINES' for more information.
Still has spots.	Covering is not intended for LED illumination. Use light diffusing acrylic sheets which are specially made for LED light source.