

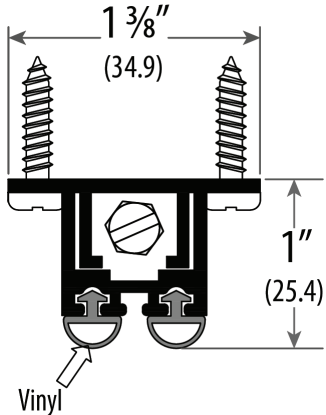

# ADB-705

Automatic Door Bottom



Vinyl

ITEM/FINISH:

## ADB-705

(for hollow metal doors)

VINYL INSERT

MILL FINISH ALUMINUM

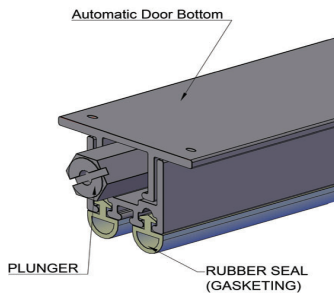

### TESTING/RATINGS:



# AUTOMATIC DOOR BOTTOMS (ADB)

## Installation Guidelines:

1. Detach door from hinge and cut mortise on the bottom of the door according to the dimensions of the unit. Reminder: If the door is fire labeled mortise preparation must be done by the door manufacturer to ensure compliance with door standards.  
**See illustration #2 for actuator/plunger hole prep.**
2. Measure the door from both ends to get the exact required length for the door bottom. Use power cutting tools like table saw or chop saw to have an excellent level cut. Important Reminder: You must trim on the opposite side of the actuating plunger. The allowable size that can be trimmed is 1-1/2" away from the screw towards the edge of the ADB unit. See illustration #1.
3. After the door has been prepped, install the door bottom with the plunger towards the hinge jamb side. Fasten unit with screws provided. Ideal clearance between the unit and the finished floor is 3/8".
4. Set the ADB by turning the actuating plunger clockwise or counter clockwise until the rubber seal gasket touches the floor surface (AFF or Threshold).

### Packaging includes:

- (1) Automatic Door Bottom
- Screw pack

### Tools Required

- Measuring tape
- Marker
- Power tools
- Screw driver
- Cutting tools

Mortised: the plunger contacts the rabbet. See illustration #3.

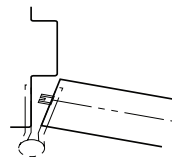
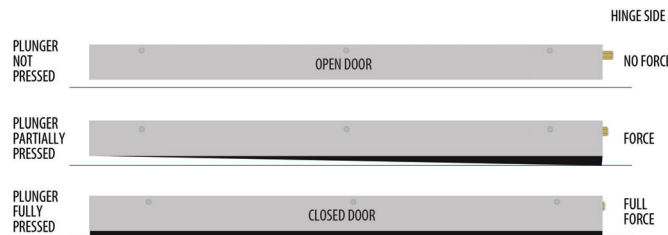

ILLUSTRATION 3



## CONCEALED (MORTISED)

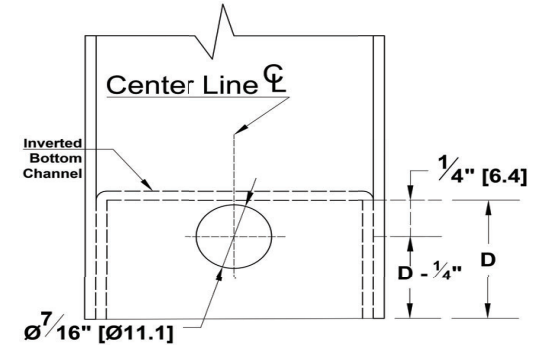
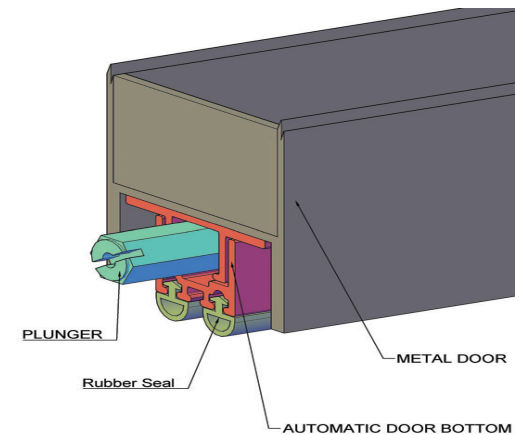

ILLUSTRATION 2: Hole prep for actuator/plunger on the hinge side of the door



### CUTTING INSTRUCTIONS

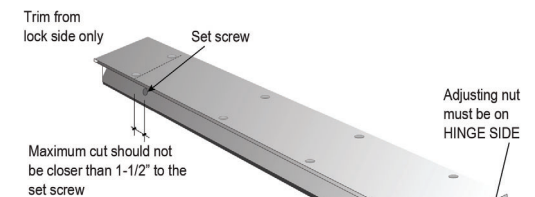

ILLUSTRATION 1 (Trimming Guideline)