

## Hydraulic 180° gate closer and hinge in one

MAMMOTH-180 (Patented)

Elegant and powerful self-closing hinge for 180° gate situations. Mammoth is perfectly fit for gates up to 150 kg and 1500 mm wide. It is equipped with a double bearing for exceptional functionality. The Active Thermal System guarantees a constant closing speed, unaffected by weather conditions. The Dino hinge is included.



### Color options

ZILV 9005

### Specifications

- ✔ Self-closing hinge with patented hydraulic damping
- ✔ Aesthetic design
- ✔ Powder coated aluminium housing
- ✔ Closing speed unaffected by temperature changes
- ✔ Easy to open: Max. 16 Nm
- ✔ Vandal-proof
- ✔ For left and right opening gates
- ✔ Easy mounting with Quick-Fix
- ✔ 2-dimensionally adjustable (2 x 20 mm)

### Order code

**MAMMOTH-180** Stylish hydraulic gate closer for heavy gates

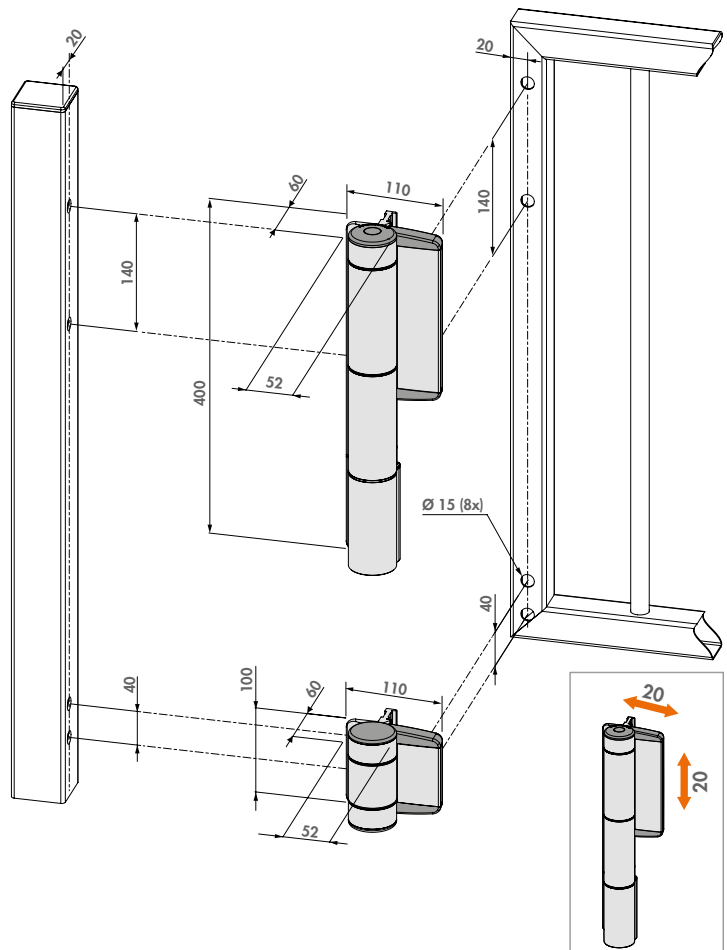

### Recommended installation tools



DRILLVISE-II

DRILLVISE-IV

CLB-MAMMOTH