

HINGE DRAWN BARREL UP

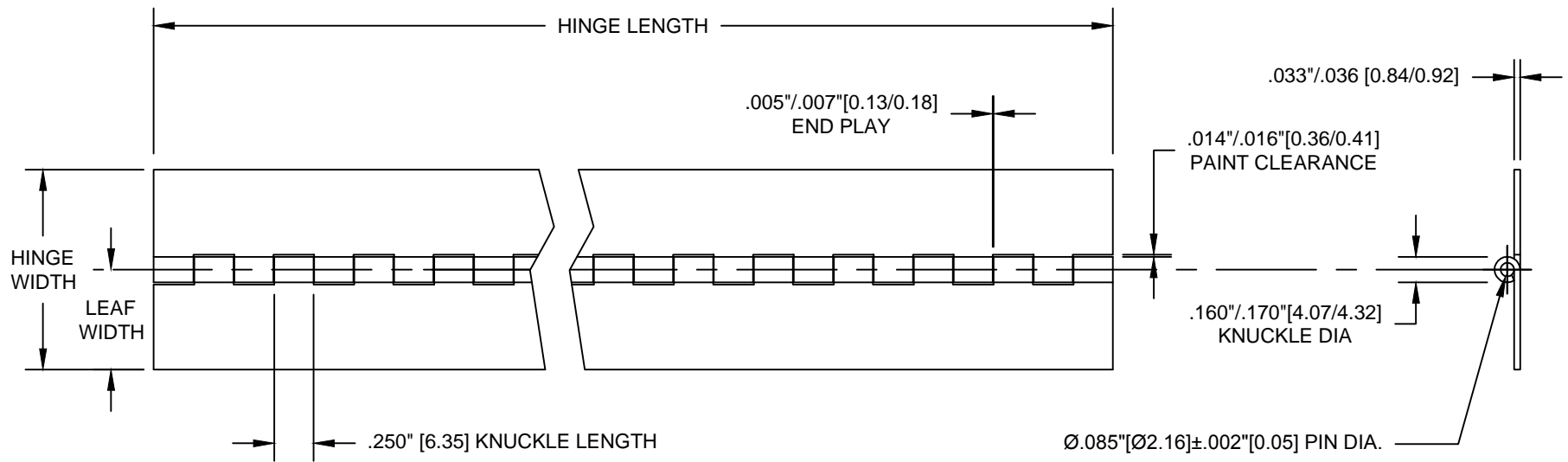

NOTES:

- 1] S&S Hinge series # 400, 4000, 500, 5000
- 2] Gauge/thickness - .033"/.036" [0.84 mm/0.92 mm].
- 3] Knuckle length - 1/4"/.250"/6.35 mm.
- 4] Pin diameter - .085"/2.16 mm.
- 5] Hinge rotates 270°.
- 6] See chart to the right for standard open widths.
- 7] Standard metals: steel, stainless. Aluminum available by special order.
- 8] Inside stop hinge available by special order - 4000 series.
- 9] "Edg-Guide" welding alignment feature available by special order - 500 series.
- 10] Inside stop hinge with "Egd-Guide" available by special order - 5000 series.

SERIES #:	HINGE WIDTH	LEAF WIDTH
399P	0.75" [19.05]	.375" [9.525]
400P	1.06" [26.93]	.531" [13.50]
404P	1.25" [31.75]	.625" [15.88]
405P	1.50" [38.10]	.750" [19.05]
408P	2.00" [50.80]	1.00" [25.40]



Continuous Hinge, Quality and Service Worldwide | Est. 1932

210 COVINGTON DRIVE
 BLOOMINGDALE, IL. 60108
 1-800-332-1227 TEL: (630) 582-9500 FAX: (630) 582-8844
www.SandSHinge.com

DRAWN BY: ENGINEERING DEPT.

DATE: CURRENT REVISION SCALE: N-T-S

PART No: 400 series, 4000 series
 500 series, 5000 series

DIMENSIONS IN:
 INCHES MILLIMETERS

S&S HINGE CO.
 STANDARD TOLERANCES

DEC	INCH	MM	THIRD ANGLE
.XX	± .030	± 0.750	
.XXX	± .015	± 0.380	
HOLE DIA	± .005	± 0.127	
ANGLE	± 3°		

CUSTOMER: _____

THIS PRINT AND/OR SPECIFICATION ARE EXCLUSIVE PROPERTY OF S&S HINGE CO. AND ARE NOT TO BE REPRODUCED, COPIED, USED OR DISCLOSED TO ANYONE WITHOUT PERMISSION.

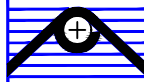

REV	DATE:	DESCRIPTION