

# HINGE DRAWN BARREL UP

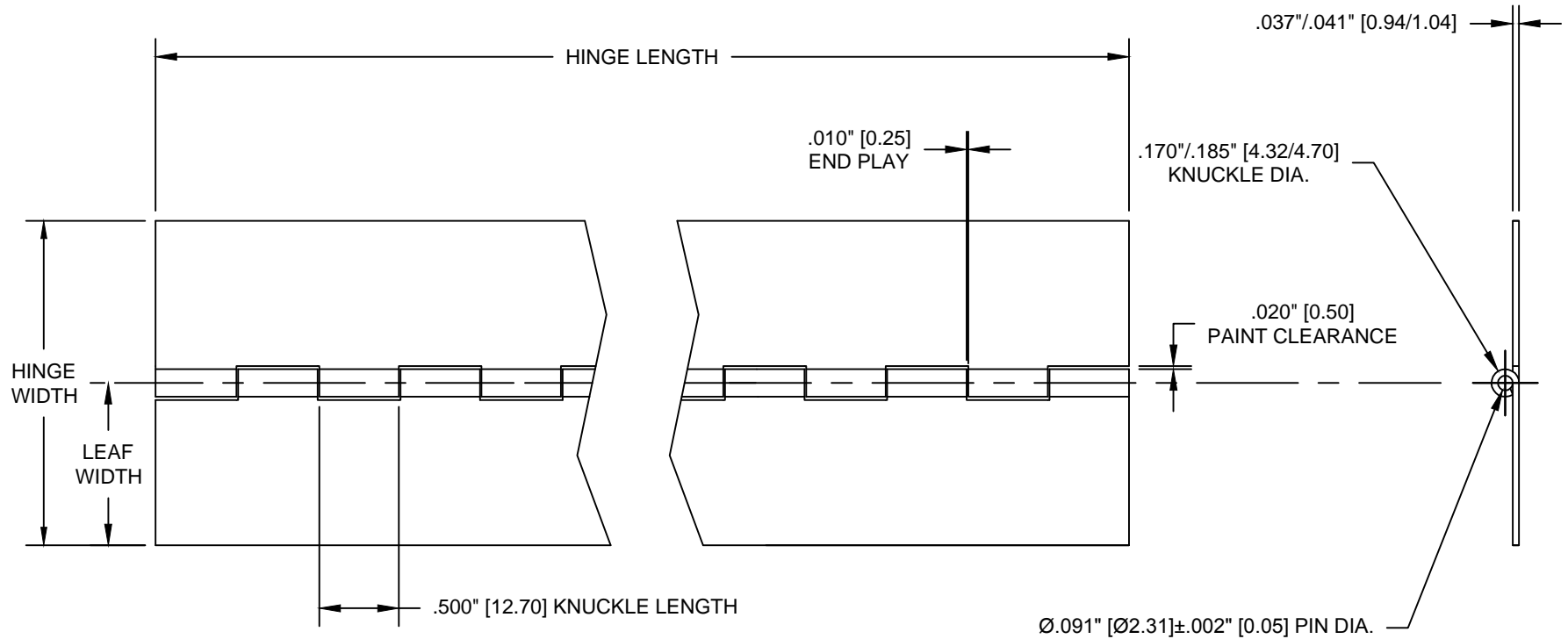

**NOTES:**

- 1] S&S Hinge series # 1000
- 2] Gauge/thickness - .037"/.041" [0.94 mm/1.04 mm].
- 3] Knuckle length - 1/2"/.500"/12.7 mm.
- 4] Pin diameter - .090"/2.31 mm.
- 5] Hinge rotates 270°.
- 6] See chart to the right for standard open widths.
- 7] Standard metals: steel, stainless, aluminum, preplated brass - & nickel, and brite annealed stainless.

SERIES #:	HINGE WIDTH	LEAF WIDTH
1001	1.06" [26.93]	.531" [13.48]
1002	1.25" [31.75]	.625" [15.87]
1003	1.50" [38.10]	.750" [19.05]
1004	2.00" [50.80]	1.00" [25.40]



Continuous Hinge, Quality and Service Worldwide | Est. 1932

210 COVINGTON DRIVE  
 BLOOMINGDALE, IL. 60108  
 1-800-332-1227 TEL: (630) 582-9500 FAX: (630) 582-8844  
[www.SandSHinge.com](http://www.SandSHinge.com)

DRAWN BY: ENGINEERING DEPT.

DATE: CURRENT REVISION      SCALE: N-T-S

PART No: **1000 SERIES**

DIMENSIONS IN: INCHES <input checked="" type="checkbox"/> MILLIMETERS <input checked="" type="checkbox"/>			
S&S HINGE CO. STANDARD TOLERANCES			
DEC	INCH	MM	THIRD ANGLE
.XX	± .030	± 0.750	
.XXX	± .015	± 0.380	
HOLE DIA	± .005	± 0.127	
ANGLE	± 3°		

THIS PRINT AND/OR SPECIFICATION ARE EXCLUSIVE PROPERTY OF S&S HINGE CO. AND ARE NOT TO BE REPRODUCED, COPIED, USED OR DISCLOSED TO ANYONE WITHOUT PERMISSION.

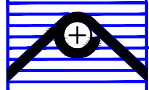

REV	DATE:	DESCRIPTION
-----	-------	-------------

CUSTOMER: