



## LCS - Lincat Lynx 400 Electric Counter-top Chip Scuttle - W 285 mm - 0.25 kW

Ensure your chips and other fried food are kept at the optimum temperature with the Lynx 400 Chip Scuttle.

- ✔ Provide a continuous supply of chips and other fried food, quickly and easily
- ✔ The perforated drain plates ensures any excess oil is drained away, helping to keep chips crisp
- ✔ Adjustable temperature control
- ✔ Easy to clean removable drain plates and interior
- ✔ No installation required, just plug in.

### Specifications

#### Summary

<b>Brand</b>	Lincat
<b>Range</b>	Lynx 400
<b>Power Type</b>	Electric
<b>Unit Type</b>	Counter-top
<b>Available in UK Only</b>	No
<b>UK Warranty</b>	2 Years Parts and Labour Warranty
<b>Export Warranty</b>	Contact your local dealer
<b>GTIN</b>	5056105101055

#### Power and Performance

<b>Total Power kW</b>	0.25
<b>IP Rating</b>	IP23
<b>Temperature Control</b>	Mechanical

#### Key Specifications

<b>Heated Base</b>	Yes
<b>Heated Gantry</b>	No

#### Weights and Dimensions

<b>Unit Height (External) mm</b>	232
<b>Unit Width (External) mm</b>	285
<b>Unit Depth (External) mm</b>	400
<b>Net Weight Kg</b>	6.7

#### Supply Connections

<b>Requires Installation</b>	No
<b>Requires Electrical Supply</b>	Yes
<b>UK 3 Pin Plug</b>	Yes
<b>Requires Hardwiring</b>	No
<b>Electrical Supply Rating Watts</b>	250
<b>Single Phase Amps</b>	1.1
<b>Single Phase Voltage</b>	230

#### Shipping

<b>Packed Weight Kg</b>	7.37
<b>Packed Height cm</b>	42
<b>Packed Width cm</b>	48
<b>Packed Depth cm</b>	38

### Technical Picture

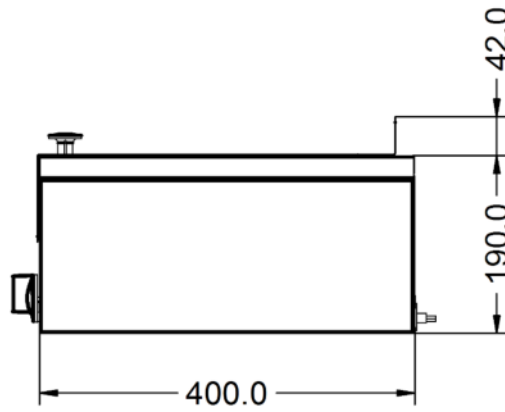
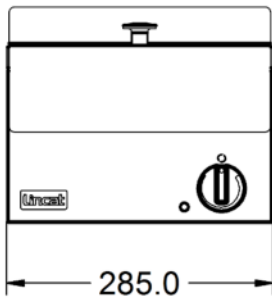
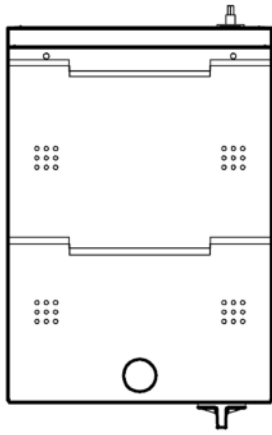

**Lincat Limited**

Whisby Road,  
Lincoln, LN6 3QZ,  
United Kingdom

**Company No:** 2175448

A member company of



**Customer Care**

**Tel:** +44 1522 875500  
**Email:** care@lincat.co.uk

**Export Customers**

**Tel:** +44 1522 875536  
**Email:** export@lincat.co.uk

**Opening Hours**

**Monday – Friday:**  
8.30am – 5pm