

The

Axis

Trichome Separator

PurePressure's Axis trichome separator offers unparalleled control, machine utilization, and scalability for solventless processors. Its unique design separates the washing vessel from the source of agitation, which enables extractors to wash in one vessel while the next one is being filled, pre-soaked, or filtered. This creates massive efficiencies both in terms of batch processing throughput and labor cost savings. Built in the USA, the Axis' stainless steel housing and washdown rated electronics allows for easy cleaning and sanitation. It also features a joystick that's coupled with a touch screen control panel to mimic hand-paddle agitation.



1 Axis = 2x competitor machines

The modular, multi-vessel nature of the Axis agitation process allows nearly 2x the throughput compared to other single-vessel agitation machines.

ROI achievable in under 1 week

The massive efficiency gains in hash production will allow you to see a return on your investment in under 1 week.

Double your throughput

Wash twice as much hash with the same labor force compared to hand paddling.

Limitless control

Custom hash washing recipes can be created in multiple ways, which are then endlessly repeatable, to ensure unparalleled washing consistency between batches. The Axis is capable of running custom created recipes that can be made by stringing together your custom recorded patterns, during live production runs, or from tables. It also comes with pre-set recipes loaded into the control panel for exceptional agitation control.

Patterns: recorded short, discrete movements that are intended to be looped.

Recipes: one or more looping patterns, which can be created with the joystick directly or with a table on the touchscreen interface.

Technical specifications

Product certification statement

PurePressure has contracted a Third-Party Product Safety Test House to evaluate this product for electrical compliance to UL 763 for Motor-Operated Commercial Food Preparing Machines.

Product scope & intended use

The Axis trichome separator works exclusively with PurePressure Bruteless vessels (30, 44 & 65 gallon sizes). The unit operates by agitating a slurry with a mixer head and is intended for use with ice water hash extraction methods.

Maintenance schedule

Daily: Clean, wipe down, visual inspection.

Weekly: Inspect hinges & hinge hardware for loose or backed out bolts.

120 hours: Check belt tension.
See *belt tensioning instructions* for additional detail.

Monthly:
Inspect the interior of the control stand electrical enclosure for moisture.
Check vertical movement and pivoting for smooth operation.
Check filter regulator for condensation.

6 Months: Grease hinges.

20,000 hours (L10 predicted life): Replace bearings, drive belt, motor & gearbox.

Specification	
Weight	Axis: 260 lb, control stand: 90 lb, total weight: 350 lb
Input voltage & amp draw	120V Peak: 7A Continuous: 3A ; 240V Peak: 4A Continuous: 2A
Fuses (2x)	Type: Fast acting 250 V Current: 10A Dimensions: 5mm x 20mmv
Compressed air requirements	120 psi, < 1 CFM
Paddle motor speed	2 - 70 RPM
Paddle construction	304 stainless steel with quick disconnect & dishwasher safe for cleaning
Enclosure construction	304 stainless steel
Frame construction	6061 aluminum & stainless steel hardware
Vessel wash guard construction	Removable PETG with 304 stainless steel attachment ring
Axis trichome separator with UL508A control panel	IP65 washdown rated*
Ceiling height	94" standard, 85" upon request

Product dimensions (in)

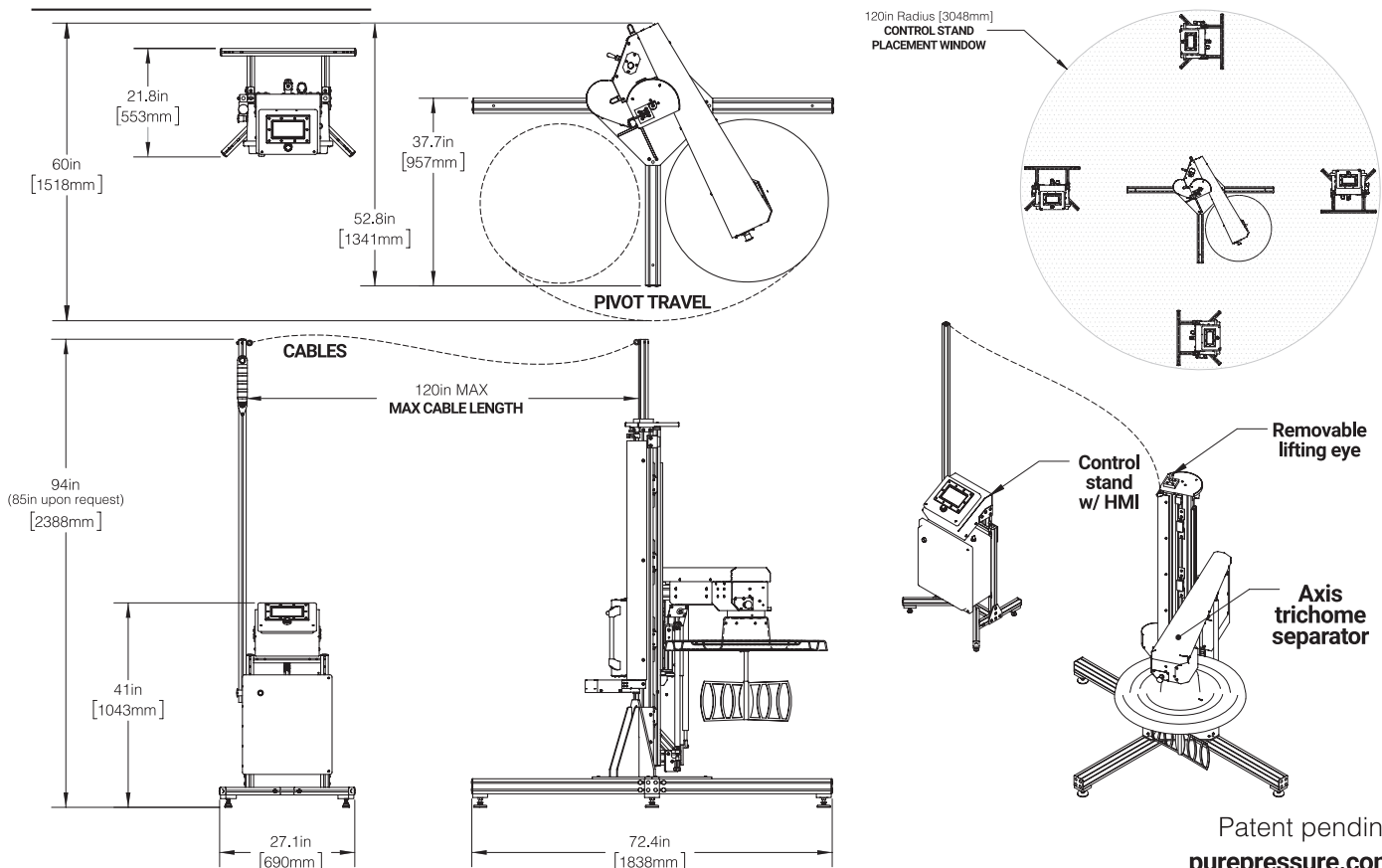

Patent pending
purepressure.com

Efficiency comparison

This graph depicts the comparison in volume of fresh frozen flower washed in a work day (8-10 hours) between the Axis trichome separator using 4x 65 gallon Bruteless vessels versus competitor automated washing units.

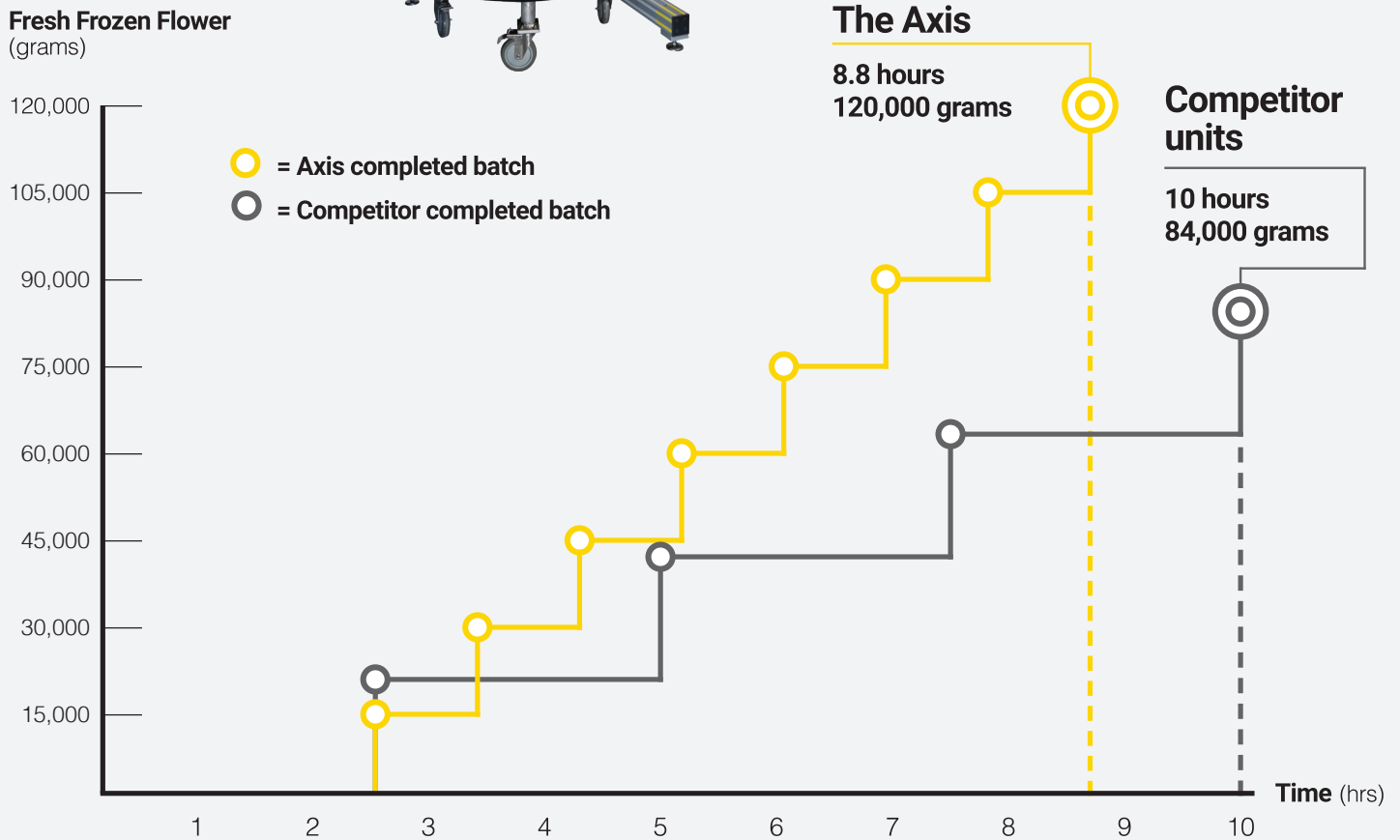

Axis 4 vessel system workflow

This diagram depicts equipment utilization and is not intended for space planning configurations. For more information on facility designs, floor planning, and training, contact PureCannalabs.



PureCannalabs

**CANNABIS EXTRACTION
CONSULTING & SOLVENTLESS
SPECIALISTS**

VISIT PURECANNALABS.COM
TO GET STARTED

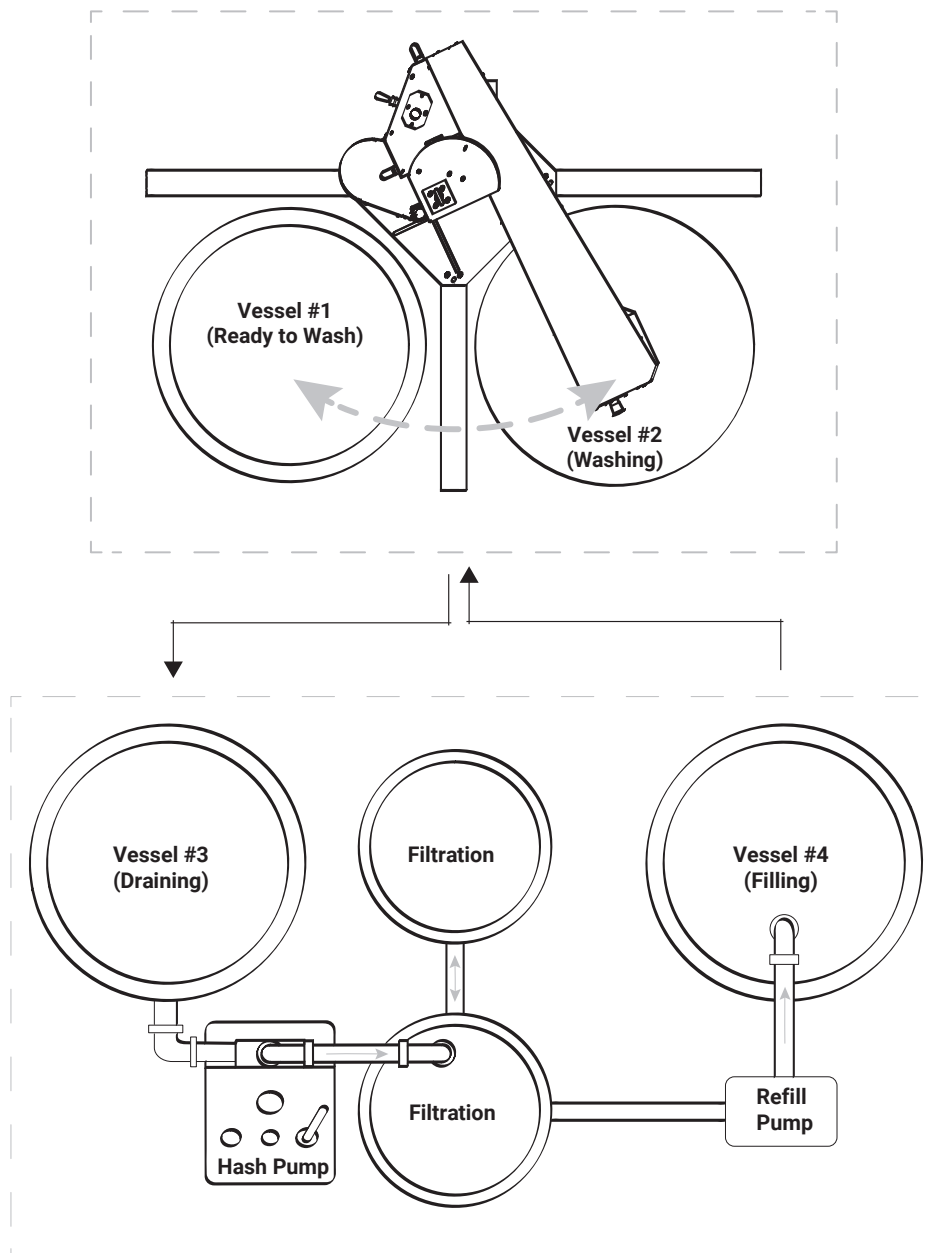

Expand your operation with Bruteless hash washing vessels

PurePressure's Bruteless vessels set the standard for making ice water hash. Our passivated 304 stainless steel, food contact safe Bruteless sanitary welded construction helps you make better hash and manage fluid transfer with ease.



65 Gallon Bruteless

Per batch capacity: 15,000 grams
Fresh frozen flower



44 Gallon

Per batch capacity:
10,000 grams
Fresh frozen flower



30 Gallon

Per batch capacity:
5,000 grams
Fresh frozen flower

Shop Bruteless now at purepressure.com

Axis trichome separator throughput tables

Study explanation

To create the tables below we performed a time study of a 9 hour work day with 2 extraction professionals using the Axis trichome separator. The work day included preparation, hash washing, hash collection, and cleanup. To maximize machine utilization of the Axis, the preparation and hash collection processes were executed simultaneously and separate from the Axis agitation process (hash washing). Most facilities can achieve optimal throughput using 4 vessels. If your filtration time exceeds your hash washing time, the required number of vessels increases.

Study assumptions

Continuous operation of the Axis with an average time between batches being 2 minutes to change positions.

Terminology

Wash: the process of removing trichome heads from the flower through agitation with the Axis trichome separator.

Batch: a series of one or more washes, performed to ensure as many of the trichome heads have been detached from the flower as possible.

Work day: 8 hours of hash washing and 1 hour of clean up.

[Continue to tables](#)

A work day with 65 gallon Bruteless vessels

Number of completed batches per 8 hour shift

 = Common zones of operation

Wash Time (min)	Washes per batch					
	1	2	3	4	5	6
5	68	34	22	17	13	11
10	40	20	13	10	8	6
15	28	14	9	7	5	4
20	21	10	7	5	4	3
25	17	8	5	4	3	2
30	15	7	5	3	3	2
35	12	6	4	3	2	2

Fresh frozen flower material input (wet grams)

Based on 15,000 grams per 65 gallon vessel

Wash Time (min)	Washes per batch					
	1	2	3	4	5	6
5	1,020,000	510,000	330,000	255,000	195,000	165,000
10	600,000	300,000	195,000	150,000	120,000	90,000
15	420,000	210,000	135,000	105,000	75,000	60,000
20	315,000	150,000	105,000	75,000	60,000	45,000
25	255,000	120,000	75,000	60,000	45,000	30,000
30	225,000	105,000	75,000	45,000	45,000	30,000
35	180,000	90,000	60,000	45,000	30,000	30,000

Dry hash output at a 4% / 6% yield (dry grams)

Wash Time (min)	Washes per batch					
	1	2	3	4	5	6
5	40,800 / 61,200	20,400 / 30,600	13,200 / 19,800	10,200 / 15,300	7,800 / 11,700	6,600 / 9,900
10	24,000 / 36,000	12,000 / 18,000	7,800 / 11,700	6,000 / 9,000	4,800 / 7,200	3,600 / 5,400
15	16,800 / 25,200	8,400 / 12,600	5,400 / 8,100	4,200 / 6,300	3,000 / 4,500	2,400 / 3,600
20	12,600 / 18,900	6,000 / 9,000	4,200 / 6,300	3,000 / 4,500	2,400 / 3,600	1,800 / 2,700
25	10,200 / 15,300	4,800 / 7,200	3,000 / 4,500	2,400 / 3,600	1,800 / 2,700	1,200 / 1,800
30	9,000 / 13,500	4,200 / 6,300	3,000 / 4,500	1,800 / 2,700	1,800 / 2,700	1,200 / 1,800
35	7,200 / 10,800	3,600 / 5,400	2,400 / 3,600	1,800 / 2,700	1,200 / 1,800	1,200 / 1,800

A work day with 44 gallon Bruteless vessels

Number of completed batches per 8 hour shift

 = Common zones of operation

Wash Time (min)	Washes per batch					
	1	2	3	4	5	6
5	68	34	22	17	13	11
10	40	20	13	10	8	6
15	28	14	9	7	5	4
20	21	10	7	5	4	3
25	17	8	5	4	3	2
30	15	7	5	3	3	2
35	12	6	4	3	2	2

Fresh frozen flower material input (wet grams)

Based on 10,000 grams per 44 gallon vessel

Wash Time (min)	Washes per batch					
	1	2	3	4	5	6
5	680,000	340,000	220,000	170,000	130,000	110,000
10	400,000	200,000	130,000	100,000	80,000	60,000
15	280,000	140,000	90,000	70,000	50,000	40,000
20	210,000	100,000	70,000	50,000	40,000	30,000
25	170,000	80,000	50,000	40,000	30,000	20,000
30	150,000	70,000	50,000	30,000	30,000	20,000
35	120,000	60,000	40,000	30,000	20,000	20,000

Dry hash output at a 4% / 6% yield (dry grams)

Wash Time (min)	Washes per batch					
	1	2	3	4	5	6
5	27,200 / 40,800	13,600 / 20,400	8,800 / 13,200	6,800 / 10,200	5,200 / 7,800	4,400 / 6,600
10	16,000 / 24,000	8,000 / 12,000	5,200 / 7,800	4,000 / 6,000	3,200 / 4,800	2,400 / 3,600
15	11,200 / 16,800	5,600 / 8,400	3,600 / 5,400	2,800 / 4,200	2,000 / 3,000	1,600 / 2,400
20	8,400 / 12,600	4,000 / 6,000	2,800 / 4,200	2,000 / 3,000	1,600 / 2,400	1,200 / 1,800
25	6,800 / 10,200	3,200 / 4,800	2,000 / 3,000	1,600 / 2,400	1,200 / 1,800	800 / 1,200
30	6,000 / 9,000	2,800 / 4,200	2,000 / 3,000	1,200 / 1,800	1,200 / 1,800	800 / 1,200
35	4,800 / 7,200	2,400 / 3,600	1,600 / 2,400	1,200 / 1,800	800 / 1,200	800 / 1,200

A work day with 30 gallon Bruteless vessels

Number of completed batches per 8 hour shift

 = Common zones of operation

Wash Time (min)	Washes per batch					
	1	2	3	4	5	6
5	68	34	22	17	13	11
10	40	20	13	10	8	6
15	28	14	9	7	5	4
20	21	10	7	5	4	3
25	17	8	5	4	3	2
30	15	7	5	3	3	2
35	12	6	4	3	2	2

Fresh frozen flower material input (wet grams)

Based on 5,000 grams per 30 gallon vessel

Wash Time (min)	Washes per batch					
	1	2	3	4	5	6
5	340,000	170,000	110,000	85,000	65,000	55,000
10	200,000	100,000	65,000	50,000	40,000	30,000
15	140,000	70,000	45,000	35,000	25,000	20,000
20	105,000	50,000	35,000	25,000	20,000	15,000
25	85,000	40,000	25,000	20,000	15,000	10,000
30	75,000	35,000	25,000	15,000	15,000	10,000
35	60,000	30,000	20,000	15,000	10,000	10,000

Dry hash output at a 4% / 6% yield (dry grams)

Wash Time (min)	Washes per batch					
	1	2	3	4	5	6
5	13,600 / 20,400	6,800 / 10,200	4,400 / 6,600	3,400 / 5,100	2,600 / 3,900	2,200 / 3,300
10	8,000 / 12,000	4,000 / 6,000	2,600 / 3,900	2,000 / 3,000	1,600 / 2,400	1,200 / 1,800
15	5,600 / 8,400	2,800 / 4,200	1,800 / 2,700	1,400 / 2,100	1,000 / 1,500	800 / 1,200
20	4,200 / 6,300	2,000 / 3,000	1,400 / 2,100	1,000 / 1,500	800 / 1,200	600 / 1,200
25	3,400 / 5,100	1,600 / 2,400	1,000 / 1,500	800 / 1,200	600 / 900	400 / 600
30	3,000 / 4,500	1,400 / 2,100	1,000 / 1,500	600 / 900	600 / 900	400 / 600
35	2,400 / 3,600	1,200 / 1,800	800 / 1,200	600 / 900	400 / 600	400 / 600