



Sogevac Neo D

NEO D 16

NEO D 25

NEO D 40

NEO D 65

Oil sealed rotary vane pump.

Original Instruction manual



P/N

970100V to 970103V

970200V to 970202V

970300V to 970302V

970400V to 970402V

970102A33

970202A33

970302A33

970402A33

And their variants.

Document Y26/300731504/002/C4

Contents

Contents

		Page
	Important Safety Information	3
1	Description	6
1.1	Principle of operation	6
1.2	Technical characteristics	8
1.3	Ordering Information	21
1.4	Accessories	22
1.5	Spare parts	23
1.6	Lubricants	23
2	Transport and Storing	24
2.1	Transport and packaging	24
2.2	Mounting orientation	26
2.3	Storage	26
3	Installation	27
3.1	Installation	27
3.2	Connection to system	28
3.3	Electrical connections	29
3.4	Start-up	32
4	Operation	33
4.1	Operation	33
4.2	Shutdown	35
4.3	Ultimate pump pressure	35
4.4	Taking out of use	35
5	Maintenance	36
5.1	Safety Information	36
5.2	Maintenance Intervals	37
5.3	Service at Leybold facilities	37
5.4	Maintenance Work	39
6	Troubleshooting	44
7	Spare parts	46
	EC Conformance Declaration	48
	Declaration of Contamination of Compressors	49
	Vacuum Pumps and Components	

Important Safety Information

Important Safety Information

Indicates procedures that must be strictly observed to prevent hazards to persons. Indicates procedures that must be strictly observed to prevent damage to, or destruction of the product. Emphasizes additional application information and other useful information provided within these Operating Instructions.

Warning

Caution

Note

The Leybold SOGEVAC Neo D have been designed for safe and efficient operation when used properly and in accordance with these Operating Instructions. It is the responsibility of the user to carefully read and strictly observe all safety precautions described in this section and throughout the Operating Instructions. The SOGEVAC Neo D **must only be operated in the proper condition and under the conditions described in the Operating Instructions.** ATEX Cat 3 vacuum pumps have been specifically designed and manufactured to meet the requirements for Equipment-group II Category 3 of the "ATEX" Directive" i.e. Directive 2014/34/EU concerning equipment and protective systems intended for use in potentially explosive atmospheres. Pumps are designed for indoor use without condensation. Do not step on the pumps.

Warning



SOGEVAC pumps are not designed:

- for pumping of dusty, aggressive, corrosive, flammable, explosive or pyrophoric gases or gases mixtures
- for pumping of oxygen or other highly reactive gases with a greater concentration than atmospheric concentration (>20%) unless specific P/N and PFPE fluid are used
- for working in flammable, explosive (unless ATEX pumps are used) or dusty environment.
- For continuous duty above 800 mbar abs

For all these cases, special materials must be used. In case of doubt, please contact Leybold.

See also the limits of use indicated in the CE declaration of conformity.

Never expose part of the body to the vacuum. There is a danger of injury. Never operate the pump with an open and thus accessible inlet. Vacuum connections as well as oil filling and oil draining openings must not be opened during operation of the pump. When operating pump is hot and some surfaces could reach a temperature higher than 80°C (176°F). There is a risk of burn by touching. Depending on the process involved, dangerous substances and oil may escape from the pump. Take the necessary safety precautions!

Caution



When working on the pump system always observe the Operating Instructions.

Disconnect the unit from the power supply before starting any work.

Pump must not be operated above 2000 m sea level

High electric voltages! When touching parts at high electric voltages, there is the risk of suffering severe injuries by an electric shock! Covers marked with this symbol must only be opened by trained electricians after having reliably deenergized (lockout/tagout) the equipment. Always operate the pump with a properly connected protective earth conductor and make sure that the motor & FC connection box are closed.

Use only the Leybold frequency converter for the pumps equipped with one.

Lay the connecting lines so that these cannot be damaged. Protect the lines against humidity and contact with fluids. Avoid thermally stressing the lines by unfavorable laying. Provide strain relief for the connecting lines so that the plugs and the line connectors are not subjected to excessively high mechanical stresses.

Lay electric feed lines so that there is no risk of tripping over these.

Important Safety Information

Take appropriate precautions to ensure that the pump cannot start.

If the pump has pumped hazardous gases it will be necessary to determine the nature of the hazard involved and take the appropriate safety precautions.

Observe all safety regulations!

Take adequate safety precautions prior to opening the intake or exhaust port.

Failure to observe the following precautions could result in damage to the equipment or people!

Liquid and solid particles or dust must not enter the pump. Install the adequate filters, separators and/or condensers. In case of doubt consult Leybold.

The intake line of the pump must never be connected to a device with over atmospheric pressure. Design the exhaust line so that no pressure higher than 1,15 bar abs. (0,15 bar rel.) can occur. The pressure regulation device is to be installed by the end-user. We recommend also to collect the pump exhaust and to treat the gases in function of their nature.

Operating of the pump without oil or operating with incorrect direction of rotation can destroy the pump.

Never use discarded seals. Always assemble using new seals.

Respect the instructions concerning environment protection when discarding used oil or exhaust filters!

The pump must be packaged in such a way that it will not be damaged during shipping, and so that no harmful substances can escape from the package.

We reserve the right to alter the design or any data given in these Operating Instructions. The illustrations are not binding.

It is mandatory that these operating instructions be read and understood prior to the vacuum pump installation and start-up.

We reserve the right to alter the design or any data given in these Operating Instructions. The illustrations are not binding.

Caution: hot surface! In normal operation, the pump surface temperature can reach 85°C. There is a risk of burning. Switch off the pump and let it cool down before any intervention or take appropriate precautions. It is recommended to use an oil casing or pump touching protection at high ambient temperatures.

As a touching protection, you can use the "Noise enclosure" P/N 960331NENC or 960560NENC. The noise enclosure is an accessory not included in the pump delivery.

All work on a pump which is "still warm from operation" should be done only whilst wearing protective gloves.

Handle the pump only while vented and after having let it cool down.

Never remove the oil-fill or oil-drain plugs while the pump is running. There exists the risk of suffering burns. Always wear protective gloves and protective goggles also for protection against the oil.

Warning



Caution

Note



Important Safety Information

Some pumps use perfluoropolyether (PFPE) as lubricant.

When handling PFPE you should observe the following: During thermal decomposition at temperatures over 290 °C toxic and corrosive gases are released. This is not likely to happen in a Sogevac pump. When handling PFPE keep it away from open fires. Do not smoke with PFPE on your fingers.



Touch the inner sections of the pumps only while wearing clean gloves and use clean tools; do the necessary work in clean and dry rooms.

Do not allow the ingestion of any objects (screws, welding beads, nuts, washers, pieces of wire, fittings etc.) through the intake port of the pump.

Objects falling into the pump can cause severe damage.

Some variants are equipped with a frequency converter giving a constant pumping speed independently of the mains frequency and regulating the pump power consumption. At high inlet pressures, the pump speed is decreased.

The pump speed can be reduced to 1200 rpm (idle mode) to reduce the power consumption w/o loss of end pressure on some pump variants. In this idle mode, the pump inlet pressure must remain below 10 mbar

Information to user

The user's manual or instruction manual for an intentional or unintentional radiator shall caution the user that changes, or modifications not expressly approved by the party responsible for compliance could void the user's authority to operate the equipment.

Note: This equipment has been tested and found to comply with the limits for a Class B, group 1 digital device, pursuant to part 15 of the FCC Rules. These limits are designed to provide reasonable protection against harmful interference when the equipment is operated in a commercial environment. This equipment generates, uses, and can radiate radio frequency energy and, if not installed and used in accordance with the instruction manual, may cause harmful interference to radio communications. Operation of this equipment in a residential area is likely to cause harmful interference in which case the user will be required to correct the interference at his own expense.

Description

1. Description

SOGEVAC pumps are designed for pumping of inert gases in the range of medium vacuum, between atmospheric pressure and end pressure of the pump. When removing condensable vapors, a gas ballast valve must be installed or opened.

1.1 Principle of operation

The SOGEVAC Neo D are oil-sealed rotary vane pumps. The anti-suckback valve, gas ballast valve, exhaust filter, oil return circuit and oil cooling oil are integrated functional elements. The pumps are driven by a directly flanged motor.

The rotor mounted eccentrically in the pump cylinder has three vanes which divide the pump chamber into several compartments. The volume of each changes periodically with the rotation of the rotor. As the rotor rotates, the intake portion of the pumping chamber expands and sucks gas thru the intake port. The gas passes through the dirt trap and the open anti-suckback valve and enters the pump chamber. As the rotor rotates further, the vane separates part of the pump chamber from the intake port. This part of the pump chamber is reduced, and the gas is compressed. At slightly above atmospheric pressure the gas is expelled from the chamber via the exhaust valve.

Oil injected into the pump chamber serves to seal, lubricate and cool the pump. The oil entrained with the compressed gas is coarsely trapped in the oil case by deflection. Then fine filtering occurs in the exhaust filter elements.

The proportion of oil in the exhaust gas is thus reduced below the visibility threshold (over 99 % entrapment rate).

Oil trapped in the exhaust filters is returned to the inlet chamber via an oil return line.

To prevent gas flowing at atmospheric pressure from the oil reservoir into the intake port, the oil return line is controlled by a float valve.

The oil cycle is maintained by the pressure difference existing between the oil casing (pressure above or equal atmospheric pressure) and the intake port (pressure below atmospheric pressure) and by an oil pump. On part of the oil is taken from the oil casing and flows via the oil filter to the bearing points of the rotor and to the pump chamber. The other part of oil injected in the pump does not run through the oil filter.

A fan running on the motor shaft generates the necessary cooling air.

Pumps depending of their P/N are equipped with a gas ballast device. If opened, a controlled amount of air so called "gas ballast" is admitted into the pump chamber. This gas ballast prevents condensation (up to the limit of

water vapor tolerance specified in the Technical Data) when pumping condensable gases or vapors. There are different types of gas ballast:

- standard manual gas ballast closed, small flow & standard flow,
- EM 24 V DC gas ballast available upon request,
- permanent, available upon request,

Note

Description

Unintentional venting of the vacuum chamber as well as oil suck back when shutting down the pump are prevented by the integrated anti suck back valve. This valve is not a safety device and its correct operation & tightness can only be assured if the valve plate & sealing zone are kept clean and in good condition.

Warning



If oil returns are to be avoided by all means, it is required to install a vacuum safety valve on the pump suction flange. Please consult us.

Inside the pump (process gas) for ATEX pumps

The inside (process gas side) of this vacuum pump is so designed and constructed so as not to present an ignition source in cases of expected malfunction. It is therefore suitable for use in situations in which explosive atmospheres caused by gases, vapors, mists do not occur in normal operation (i.e. Zone 2).

Outside the pump for ATEX pumps

The outside of this vacuum pump is also so designed and constructed so as not to present an ignition source in cases of expected malfunction. It is therefore suitable for use in situations in which explosive atmospheres caused by gases, vapors, mists cannot occur occasionally in normal operation (i.e. Zone 2).

Additionally, the outside of this vacuum pump is so designed and constructed as to prevent foreseeable ignition sources which can occur during normal operation and can ignite potentially explosive dust clouds. As such, when operated within the parameters specified within this instruction manual, the pump will provide a normal level of protection against the ignition of potentially explosive dust clouds. It is therefore also suitable for use in situations in which explosive atmospheres caused by gas or dust in air are unlikely to occur (i.e. Zone 22).

Places where explosive atmospheres in air may occur are classified in terms of three zones based on the frequency and duration of the occurrence of an explosive atmosphere. These are designated Zone 0, 1, 2 where gases, vapors or mists and Zone 20, 21, 22 where the explosive atmosphere is caused by dusts. The definitions for these Zones are given in Annex I of the "ATEX-Directive for users" i.e. Directive 99/92/EC on minimum requirements for improving the safety and health protection of workers potentially at risk from explosive atmospheres.

Guidance on how to classify a hazardous area is provided in Directive 99/92/EC and its accompanying Guide (COM (2003)515) together with the European Standard EN 60079-10 (EN 60079-10 Electrical apparatus for explosive gas atmospheres Part 10 Classification of hazardous areas). In addition the Directive 99/92/EC and its Guide provide further information on explosion prevention and protection. They can be downloaded from the EU web site: www.europa.eu.int under:

www.europa.eu.int/comm/employment_social/health_safety/publicat/com_199_92_ce_en.pdf

www.europa.eu.int/comm/employment_social/health_safety/publicat/com_199_92_ce_de.pdf

www.europa.eu.int/comm/employment_social/health_safety/publicat/com_199_92_ce_fr.pdf

Ignition temperatures of gases / vapors that may be present:

The pump is only suitable for use in situations in which potentially explosive gas or vapor atmospheres have an ignition temperature greater than 200°C. Ignition temperatures of gases and vapors can be obtained from the MSDS (Material Safety Data Sheet).

Description

Potential Ignition Sources

An Ignition hazard assessment has been carried out according to the European Standard EN 13463-1. (EN 13463-1 Non-electrical equipment for potentially explosive atmospheres — Part 1: Basic method and requirements) This has identified that the following ignition sources may occur during operation of the pump:

Potential Ignition Sources	Comments
Hot surfaces	Inside and Outside due to: <ul style="list-style-type: none">• Gas compression, vane friction etc.• Deposits on Stator/ Rotor slots• Ingress of particles
Hot gases	Produced inside pump and released at the exhaust
Mechanical sparks	Will not occur in normal operation - surfaces covered with oil inside the pump, sufficient clearance outside the pump
Electrical sparks	Motor, Accessories
Static electricity	Possible if conducting parts of pump are not earthed (Vaness, Lip seal, Exhaust filter, float valve)
Chemical reaction	Possible with process fluid/gas

Protective measures

Hot surfaces

The compression of gas which occurs during normal operation of a vacuum pump results in heating and hot surfaces. The SOGEVAC ATEX Cat. 3 vacuum pumps have been specially modified, and tests have shown that when operated under the conditions specified in this manual, the internal parts of the pump which could come into contact with a potentially explosive atmosphere could reach a maximum temperature as marked on the pump. The maximum temperature is reached after continuously operating the pump with an inlet pressure of between 300 mbar and 400 mbar. The actual temperature reached depends on the inlet pressure. Similarly, the outside of the pump could reach a maximum surface temperature as marked (These temperatures include the safety allowances specified in EN13463-1).

NOTE: Higher maximum surface temperatures will occur if the pump is filled and used with other oils than indicated on the pump. This is caused by the poorer lubricating and cooling characteristics of other oils in particular PFPE oils.

Hot gases

Hot gases are produced inside the pump due to compression of the gas in normal operation and are released at the exhaust. These should be ducted to a safe place. The pump exhaust must be collected.

Mechanical sparks

Mechanical sparks will not occur in normal operation as the internal pump surfaces are covered with oil. The external cooling fan is designed and constructed with enough clearance to prevent contact and frictional rubbing. NOTE: Ingress of particles into the pump must be avoided to prevent formation of hot spots due to rubbing or friction, where necessary a suitable ATEX filter should be used.

Description

Electrical sparks

The motor and accessories supplied with this pump are certified to the same classification as the outside of the pump. These should be installed and used in accordance with the manufacturer's instructions attached to this manual.

Static electricity

The pump should be adequately earthed to prevent the accumulation of static electricity. This will be achieved if the electrical earth cable to the motor is properly connected. No hazardous charge generation will occur on the plastic cooling fan and cowl or on the plastic coupling sleeve in normal operation. (For further information on hazards from static electricity see CENELEC report CLC/TR 50404:2003 Electrostatics - Code of practice for the avoidance of hazards due to static electricity.)

NOTE: Only original Leybold replacement exhaust gas filter cartridges and gas inlet filter cartridges should be used as these have a special construction to ensure earthing.

Chemical reactions

The pump should not be used with reactive gases that could produce an exothermic chemical reaction.

Description

1.2 Technical characteristics Sogevac NEO D 16

		NEO D 16	
		50 Hz	60 Hz
Nominal speed ¹⁾	m ³ . h ⁻¹ (cfm)	19 (11.2)	23 (13.5)
Pumping speed ¹⁾	m ³ . h ⁻¹ (cfm)	16 (9.4)	19 (11.2)
Ultimate total pressure without gas ballast ¹⁾	mbar (Torr)	≤ 8 x 10 ⁻³ (≤ 6 x 10 ⁻³)	
Ultimate total pressure with standard gas ballast ¹⁾	mbar (Torr)	≤ 0.1 (≤ 0.075)	
Ambient temperature		12 ... 40 °C (54...104 °F)	
Inlet gas temperature		-20 ... +60 °C (-4...140 °F)	
Water vapor tolerance with standard gas ballast ¹⁾	mbar (Torr)	10 (7.5)	10 (7.5)
Water vapor capacity with standard gas ballast	kg.h ⁻¹ (qt/h)	0.03 (0.03)	0.04 (0.04)
Noise level ²⁾	dB (A)	54	55
Leak rate	mbar.l.s ⁻¹	≤1.10 ⁻³	≤1.10 ⁻³
Rated rotational speed	min. -1	1500	1800
Net weight (with oil filling)	kg (lbs)	49 (108)	
Protection level		IP55 three phase drives IP40 single phase drives	
Oil capacity	l (qt)	1.5 (1.59)	
Intake connection		DN 25 ISO-KF	
Exhaust connection		DN 25 ISO-KF	

1) to DIN 28400 and following numbers, with standard gas ballast

2) operated at the ultimate pressure without gas ballast, free-field measurement at a distance of 1 m

Conversion factors	Different pressure units			Different pumping speed units		
	mbar (millibar)	torr	inches Hg vacuum	m ³ .h ⁻¹	l.s ⁻¹	cfm
1 lb = 0.453 kg	1013	760	0	m ³ .h ⁻¹ = m ³ /h	1	0.278
1 qt = 0.946 l	400	300	18.12			
1 hp = 0.735 kW	133	100	25.98	l.s ⁻¹ = l/s	3.60	1
1 r.p.m. = 1 min ⁻¹	4	3	29.80			
1 inch = 25.4 mm	1	0.75	29.89	cfm (cubic feet per minute)	1.699	0.472
	0,1	0.75	29.92			
	1 atm (atmosphere) = 1013 mbar			Example : 1 m ³ .H ⁻¹ = 0.589 cfm		
	1 Pa (pascal) = 0.01 mbar = 10 ⁻² mbar			Note : The nominal pumping speed of		
	1 bar = 1000 mbar			a pump at 60 Hz is 20% higher than at 50 Hz		
	1 torr = 1.33 mbar					

These values are valid for the standard variants and with the use of the recommended oils acc. § 1.6.

Description

1.2 Technical characteristics Sogevac NEO D 25

		NEO D 25	
		50 Hz	60 Hz
Nominal speed ¹⁾	m ³ . h ⁻¹ (cfm)	28	34
Pumping speed ¹⁾	m ³ . h ⁻¹ (cfm)	24	29
Ultimate total pressure without gas ballast ¹⁾	mbar (Torr)	≤ 8 x 10 ⁻³ (≤ 6 x 10 ⁻³)	
Ultimate total pressure with standard gas ballast ¹⁾	mbar (Torr)	≤ 0.1 (≤ 0.075)	
Ambient temperature		12 ... 40 °C (54...104 °F)	
Inlet gas temperature		-20 ... +60 °C (-4...140 °F)	
Water vapor tolerance with standard gas ballast ¹⁾	mbar (Torr)	10 (7.5)	10 (7.5)
Water vapor capacity with standard gas ballast	kg.h ⁻¹ (qt/h)	0.05 (0.05)	0.06 (0.06)
Noise level ²⁾	dB (A)	54	55
Leak rate	mbar.l.s ⁻¹	≤1.10 ⁻³	≤1.10 ⁻³
Rated rotational speed	min. -1	1500	1800
Protection level		IP55 three phase drives IP40 single phase drives	
Net weight (with oil filling)	kg (lbs)	48 (105)	
Oil capacity	l (qt)	1.5 (1.59)	
Intake connection		DN 25 ISO-KF	
Exhaust connection		DN 25 ISO-KF	

1) to DIN 28400 and following numbers, with standard gas ballast

2) operated at the ultimate pressure without gas ballast, free-field measurement at a distance of 1 m

Conversion factors	Different pressure units				Different pumping speed units		
	mbar (millibar)	torr	inches Hg vacuum		m ³ .h ⁻¹	l.s ⁻¹	cfm
1 lb = 0.453 kg	1013	760	0	m ³ . h ⁻¹ = m ³ /h	1	0.278	0.589
1 qt = 0.946 l	400	300	18.12				
1 hp = 0.735 kW	133	100	25.98	l.s ⁻¹ = l/s	3.60	1	2.12
1 r.p.m. = 1 min ⁻¹	4	3	29.80				
1 inch = 25.4 mm	1	0.75	29.89	cfm (cubic feet per minute)	1.699	0.472	1
	0,1	0.75	29.92				
1 atm (atmosphere) = 1013 mbar				Example : 1 m ³ .H ⁻¹ = 0.589 cfm			
1 Pa (pascal) = 0.01 mbar = 10 ⁻² mbar				Note : The nominal pumping speed of			
1 bar = 1000 mbar				a pump at 60 Hz is 20% higher than at 50 Hz			
1 torr = 1.33 mbar							

These values are valid for the standard variants and with the use of the recommended oils acc. § 1.6.

Description

1.2 Technical characteristics Sogevac NEO D 40

		NEO D 40	
		50 Hz	60 Hz
Nominal speed ¹⁾	m ³ . h ⁻¹ (cfm)	47	56
Pumping speed ¹⁾	m ³ . h ⁻¹ (cfm)	40	48
Ultimate total pressure without gas ballast ¹⁾	mbar (Torr)	≤ 8 x 10 ⁻³ (≤ 6 x 10 ⁻³)	
Ultimate total pressure with standard gas ballast ¹⁾	mbar (Torr)	≤ 0.1 (≤ 0.075)	
Ambient temperature		12 ... 40 °C (54...104 °F)	
Inlet gas temperature		-20 ... +60 °C (-4...140 °F)	
Water vapor tolerance with standard gas ballast ¹⁾	mbar (Torr)	10 (7.5)	10 (7.5)
Water vapor capacity with standard gas ballast	kg.h ⁻¹ (qt/h)	0.28 (0.30)	0.34 (0.36)
Noise level ²⁾	dB (A)	57	58
Leak rate	mbar.l.s ⁻¹	≤1.10 ⁻³	≤1.10 ⁻³
Rated rotational speed	min. -1	1500	1800
Protection level		IP55 three phase drives IP40 single phase drives	
Net weight (with oil filling)	kg (lbs)	80 (176)	
Oil capacity	l (qt)	3 (3.2)	
Intake connection		DN 40 ISO-KF	
Exhaust connection		DN 40 ISO-KF	

1) to DIN 28400 and following numbers, with standard gas ballast

2) operated at the ultimate pressure without gas ballast, free-field measurement at a distance of 1 m

Conversion factors	Different pressure units			Different pumping speed units		
	mbar (millibar)	torr	inches Hg vacuum	m ³ .h ⁻¹	l.s ⁻¹	cfm
1 lb = 0.453 kg	1013	760	0	m ³ . h ⁻¹ = m ³ /h	1	0.278
1 qt = 0.946 l	400	300	18.12			
1 hp = 0.735 kW	133	100	25.98	l.s ⁻¹ = l/s	3.60	1
1 r.p.m. = 1 min ⁻¹	4	3	29.80			
1 inch = 25.4 mm	1	0.75	29.89	cfm (cubic feet per minute)	1.699	0.472
	0,1	0.75	29.92			
	1 atm (atmosphere) = 1013 mbar			Example : 1 m ³ .H ⁻¹ = 0.589 cfm		
	1 Pa (pascal) = 0.01 mbar = 10 ⁻² mbar			Note : The nominal pumping speed of		
	1 bar = 1000 mbar			a pump at 60 Hz is 20% higher than at 50 Hz		
	1 torr = 1.33 mbar					

These values are valid for the standard variants and with the use of the recommended oils acc. § 1.6.

Description

1.2 Technical characteristics Sogevac NEO D 65

		NEO D 65	
		50 Hz	60 Hz
Nominal speed ¹⁾	m ³ . h ⁻¹ (cfm)	74	89
Pumping speed ¹⁾	m ³ . h ⁻¹ (cfm)	63	76
Ultimate total pressure without gas ballast ¹⁾	mbar (Torr)	≤ 8 x 10 ⁻³ (≤ 6 x 10 ⁻³)	
Ultimate total pressure with standard gas ballast ¹⁾	mbar (Torr)	≤ 0.1 (≤ 0.075)	
Ambient temperature		12 ... 40 °C (54...104 °F)	
Inlet gas temperature		-20 ... +60 °C (-4...140 °F)	
Water vapor tolerance with standard gas ballast ¹⁾	mbar (Torr)	10 (7.5)	10 (7.5)
Water vapor capacity with standard gas ballast	kg.h ⁻¹ (qt/h)	0.36 (0.38)	0.42 (0.44)
Noise level ²⁾	dB (A)	57	58
Leak rate	mbar.l.s ⁻¹	≤1.10 ⁻³	≤1.10 ⁻³
Rated rotational speed	min. -1	1500	1800
Protection level		IP55 three phase drives IP40 single phase drives	
Net weight (with oil filling)	kg (lbs)	88 (193)	
Oil capacity	l (qt)	3 (3.2)	
Intake connection		DN 40 ISO-KF	
Exhaust connection		DN 40 ISO-KF	

1) to DIN 28400 and following numbers, with standard gas ballast

2) operated at the ultimate pressure without gas ballast, free-field measurement at a distance of 1 m

Conversion factors	Different pressure units			Different pumping speed units		
	mbar (millibar)	torr	inches Hg vacuum	m ³ .h ⁻¹	l.s ⁻¹	cfm
1 lb = 0.453 kg	1013	760	0	m ³ . h ⁻¹ = m ³ /h	1	0.278
1 qt = 0.946 l	400	300	18.12			
1 hp = 0.735 kW	133	100	25.98	l.s ⁻¹ = l/s	3.60	1
1 r.p.m. = 1 min ⁻¹	4	3	29.80			
1 inch = 25.4 mm	1	0.75	29.89	cfm (cubic feet per minute)	1.699	0.472
	0,1	0.75	29.92			
	1 atm (atmosphere) = 1013 mbar			Example : 1 m ³ .H ⁻¹ = 0.589 cfm		
	1 Pa (pascal) = 0.01 mbar = 10 ⁻² mbar			Note : The nominal pumping speed of		
	1 bar = 1000 mbar			a pump at 60 Hz is 20% higher than at 50 Hz		
	1 torr = 1.33 mbar					

These values are valid for the standard variants and with the use of the recommended oils acc. § 1.6.

Description

Dimensional drawing NEO D 16

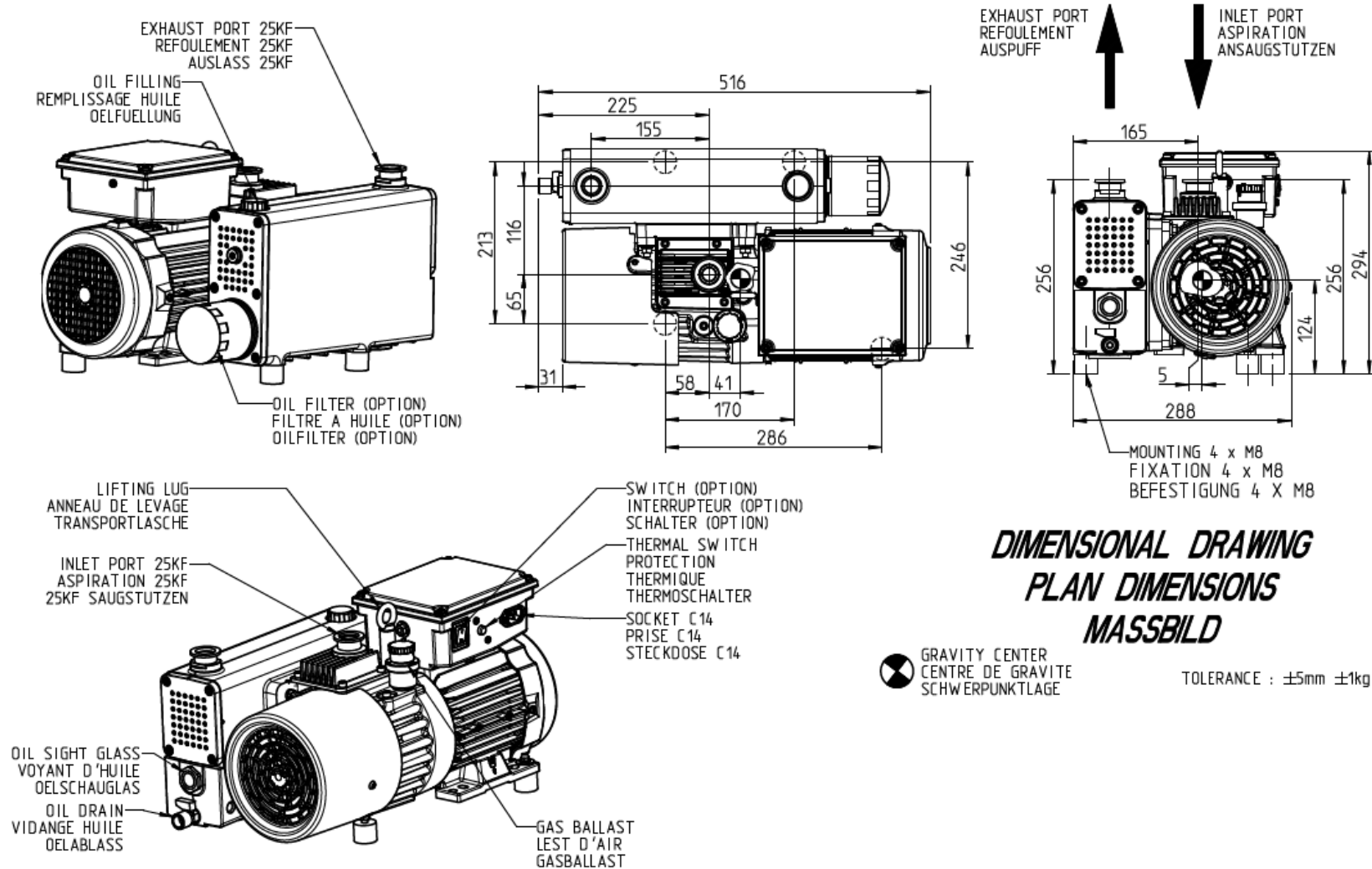

Fig 1.1

Description

Dimensional drawing NEO D 25

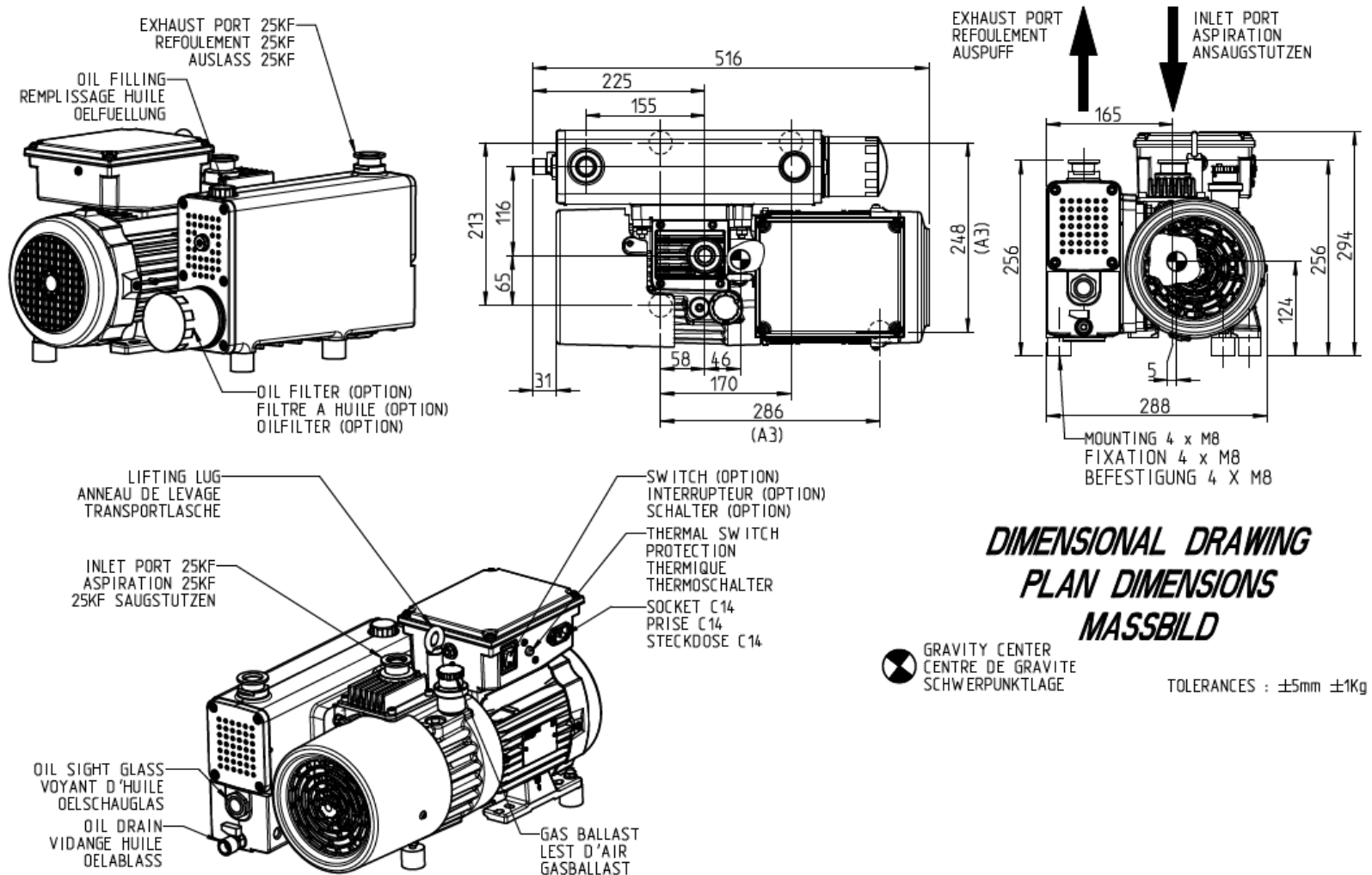

Fig 1.2

Description

Installation drawing NEO D 16 & 25

SPACE FOR EXHAUST FILTER EXCHANGE AND COOLING
ESPACE POUR MONTAGE DE LA CARTOUCHE DE REFOULEMENT ET LE REFROIDISSEMENT
PLATZ FUER MONTAGE DES AUSPUFFILTERS UND KUEHLUNG

SPACE FOR THE MOTOR VENTILATION
ESPACE POUR VENTILATION MOTEUR
PLATZ FUER MOTOR KUEHLUNG

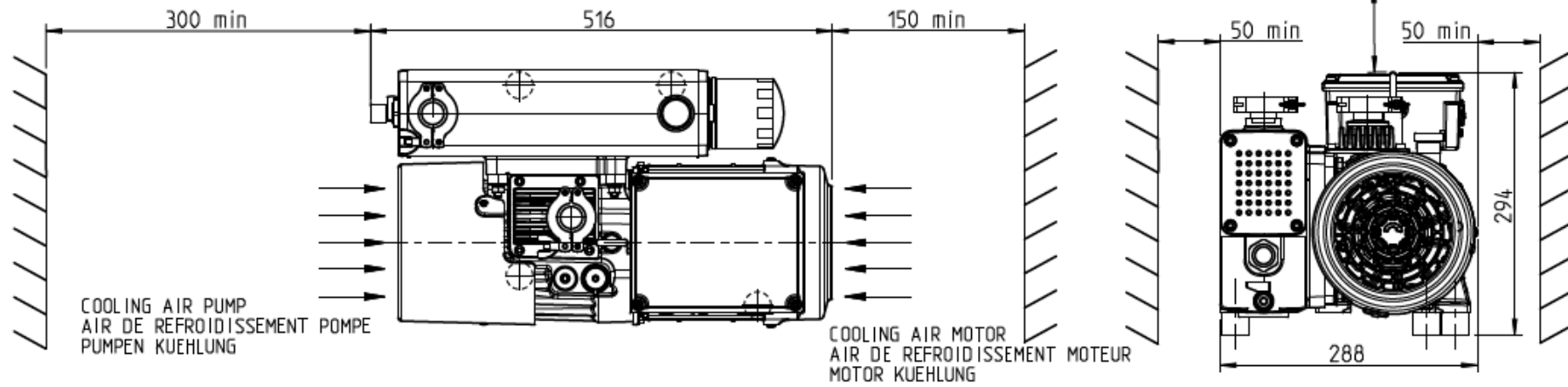

Fig 1.3

Description

Dimensional drawing NEO D 40

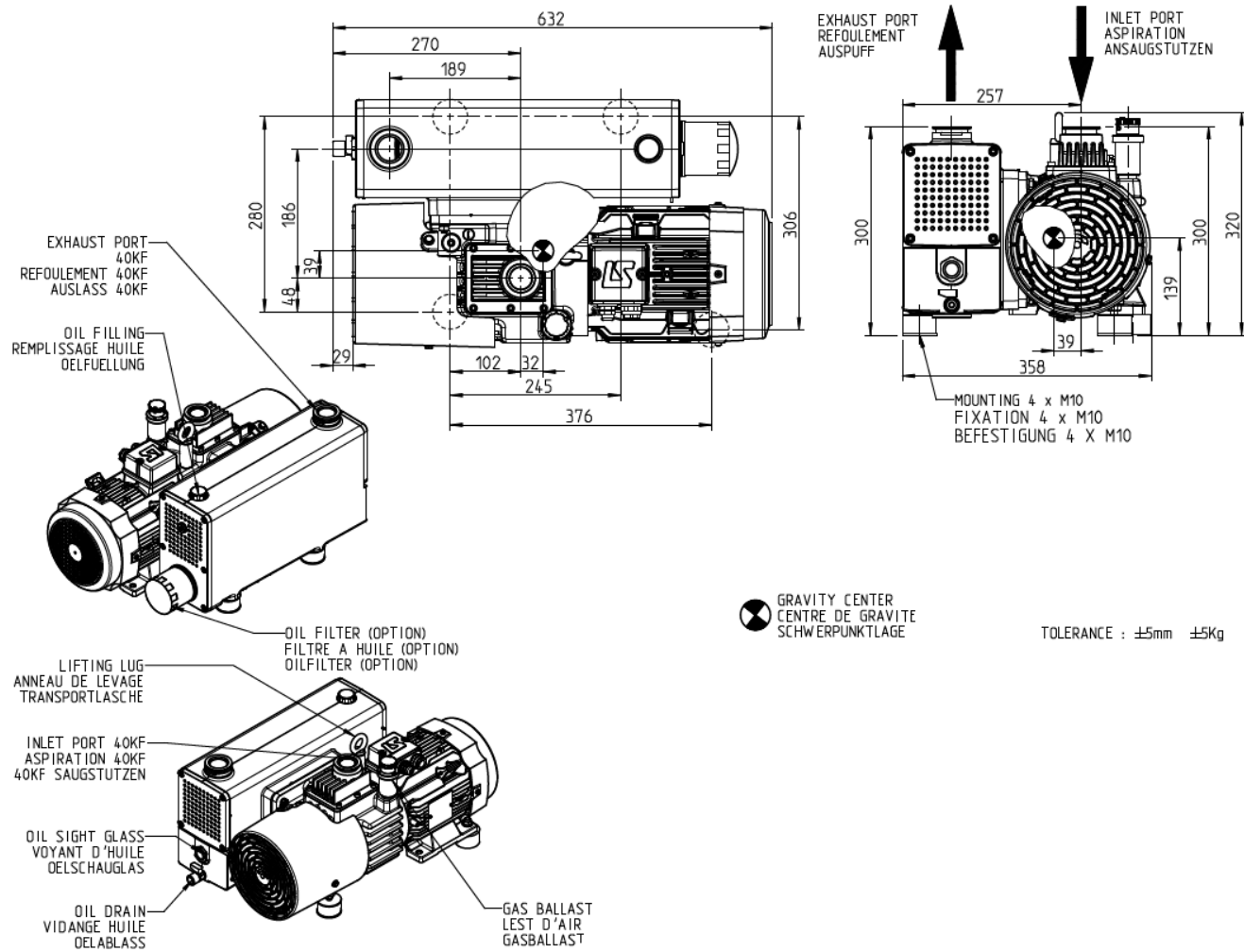

Fig 1.4

Description

Dimensional drawing NEO D 65

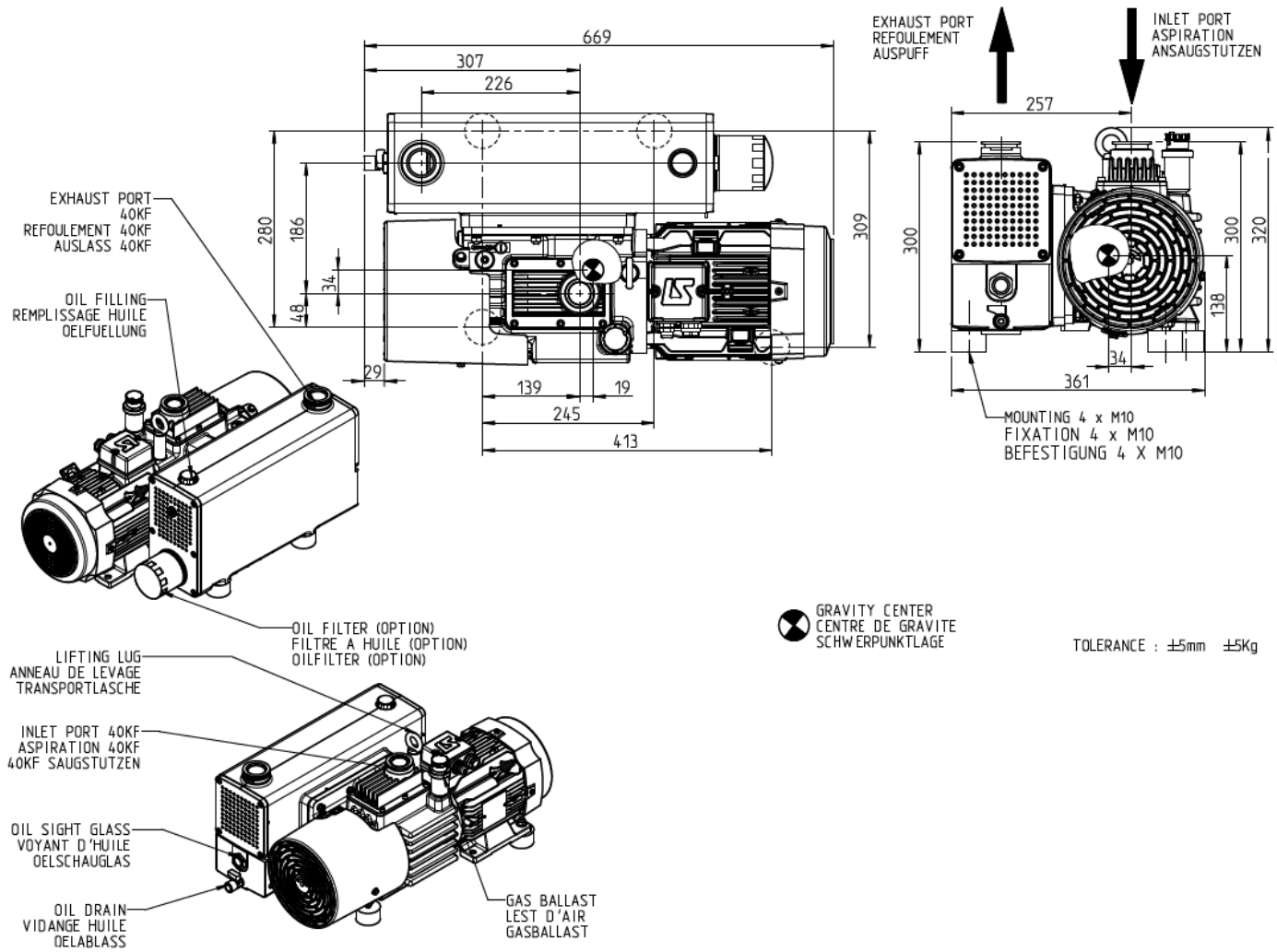
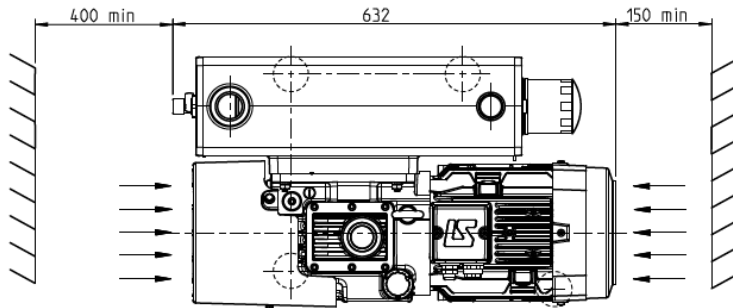

Fig 1.5

Installation drawing NEO D 40

SPACE FOR EXHAUST FILTER EXCHANGE AND COOLING
 ESPACE POUR MONTAGE DE LA CARTOUCHE DE REFOULEMENT ET LE REFROIDISSEMENT
 PLATZ FUER MONTAGE DES AUSPUFF-FILTERS UND KUEHLUNG

SPACE FOR THE MOTOR VENTILATION
 ESPACE POUR VENTILATION MOTEUR
 PLATZ FUER MOTOR KUEHLUNG



COOLING AIR PUMP
 AIR DE REFROIDISSEMENT POMPE
 PUMPEN KUEHLUNG

COOLING AIR MOTOR
 AIR DE REFROIDISSEMENT MOTEUR
 MOTOR KUEHLUNG

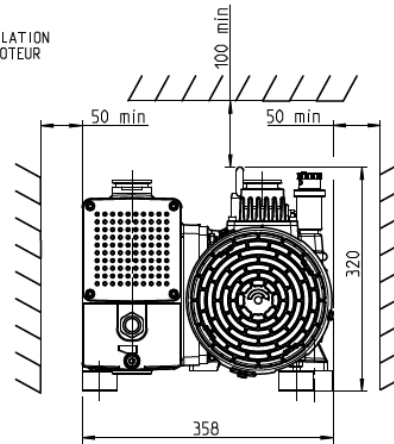

Installation drawing NEO D 65

SPACE FOR EXHAUST FILTER EXCHANGE AND COOLING
 ESPACE POUR MONTAGE DE LA CARTOUCHE DE REFOULEMENT ET LE REFROIDISSEMENT
 PLATZ FUER MONTAGE DES AUSPUFF-FILTERS UND KUEHLUNG

SPACE FOR THE MOTOR VENTILATION
 ESPACE POUR VENTILATION MOTEUR
 PLATZ FUER MOTOR KUEHLUNG

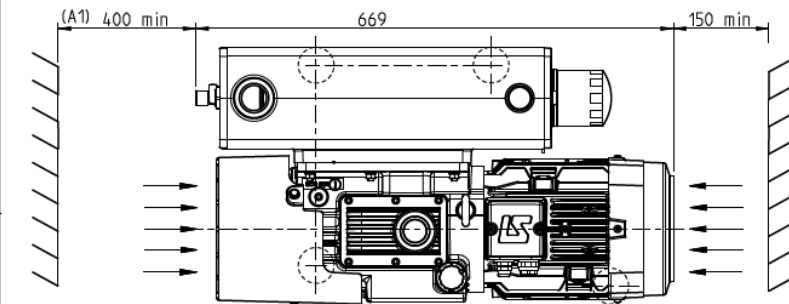

COOLING AIR PUMP
 AIR DE REFROIDISSEMENT POMPE
 PUMPEN KUEHLUNG

COOLING AIR MOTOR
 AIR DE REFROIDISSEMENT MOTEUR
 MOTOR KUEHLUNG

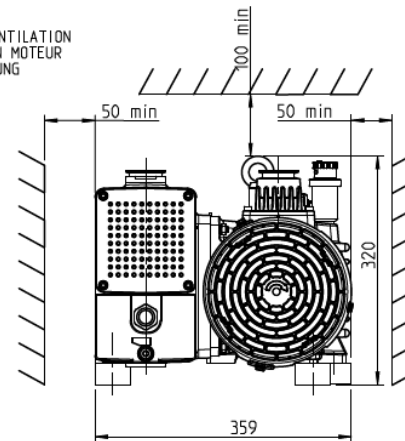
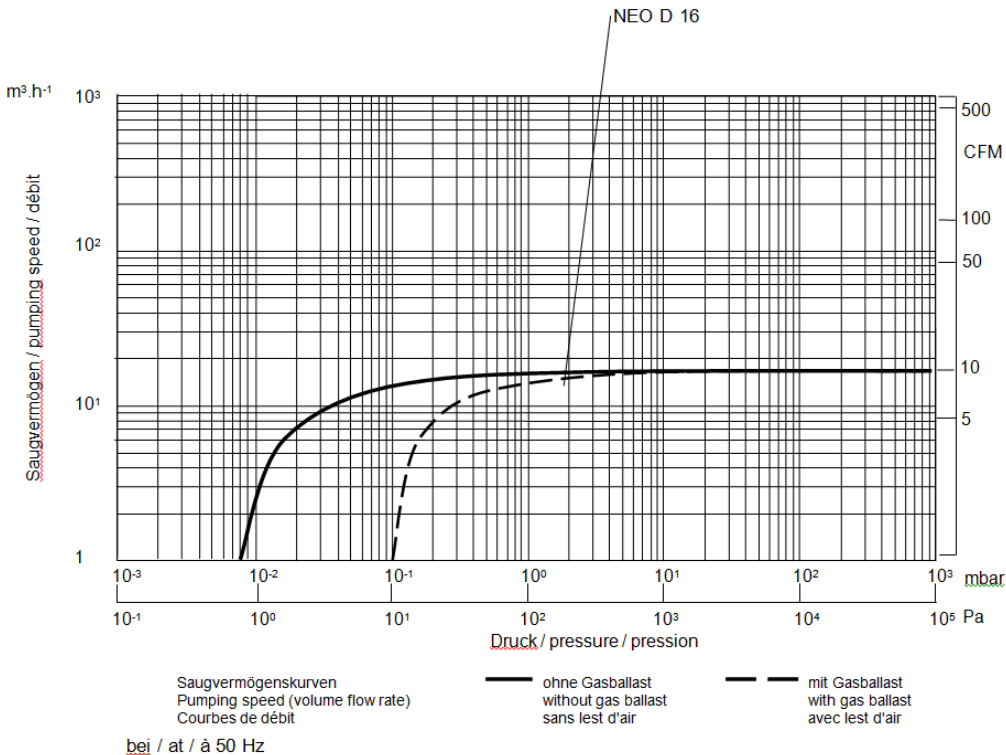
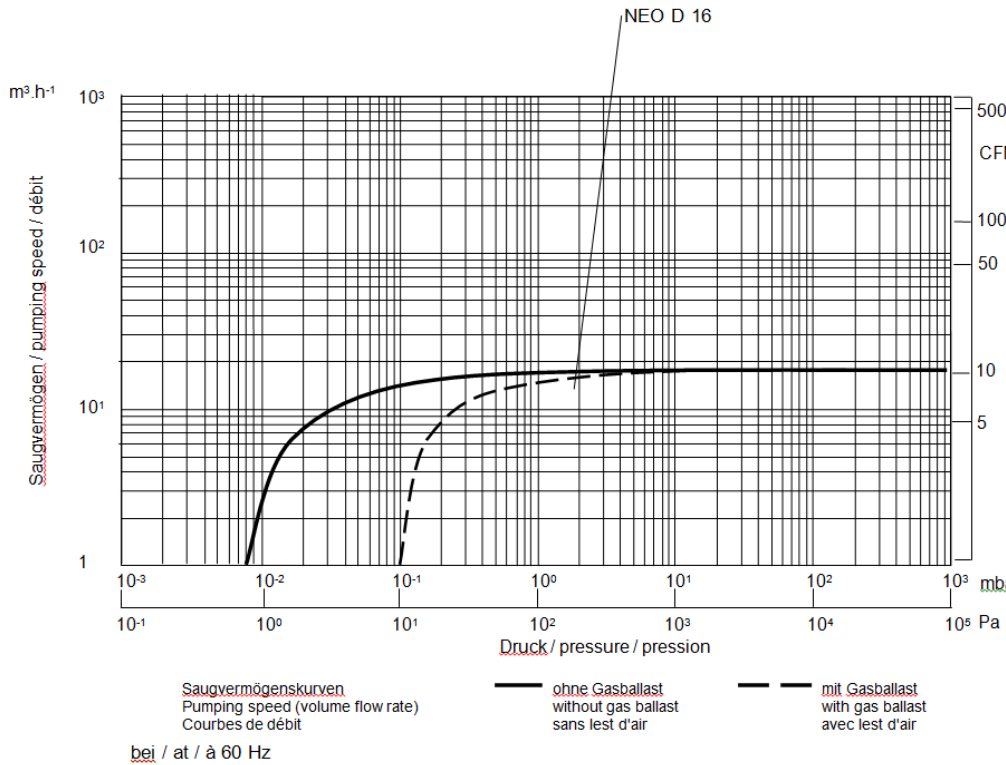

Fig 1.6

NEO D 16 Pumping speed curve 50 Hz



NEO D 16 Pumping speed curve 60 Hz



NEO D 25 Pumping speed curve 50 Hz

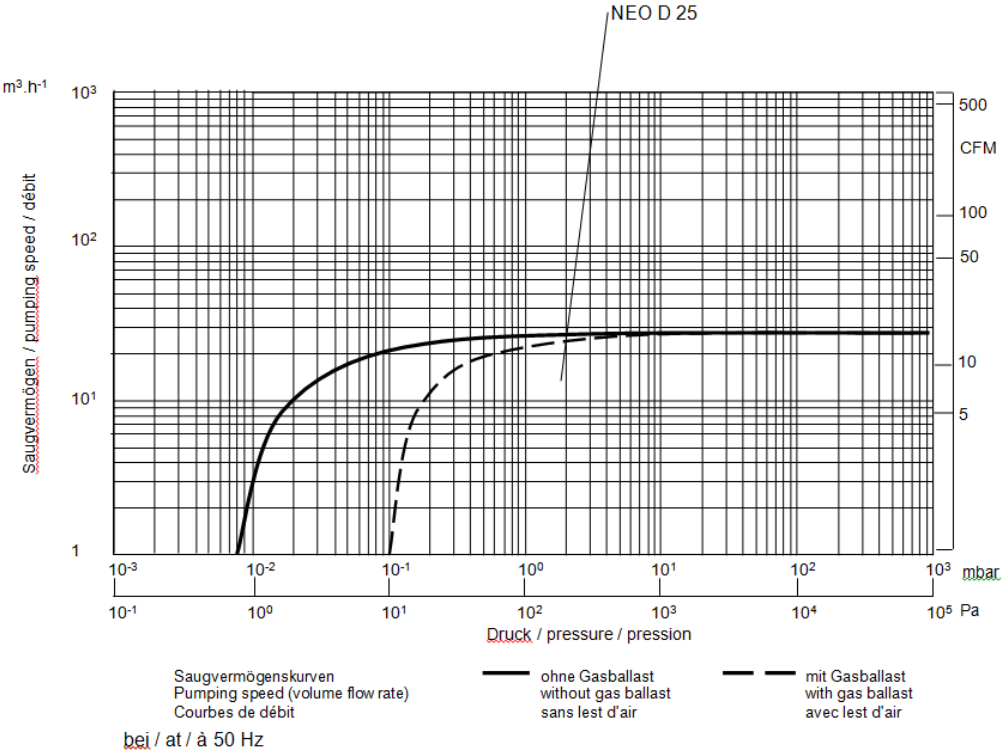

NEO D 25 Pumping speed curve 60 Hz

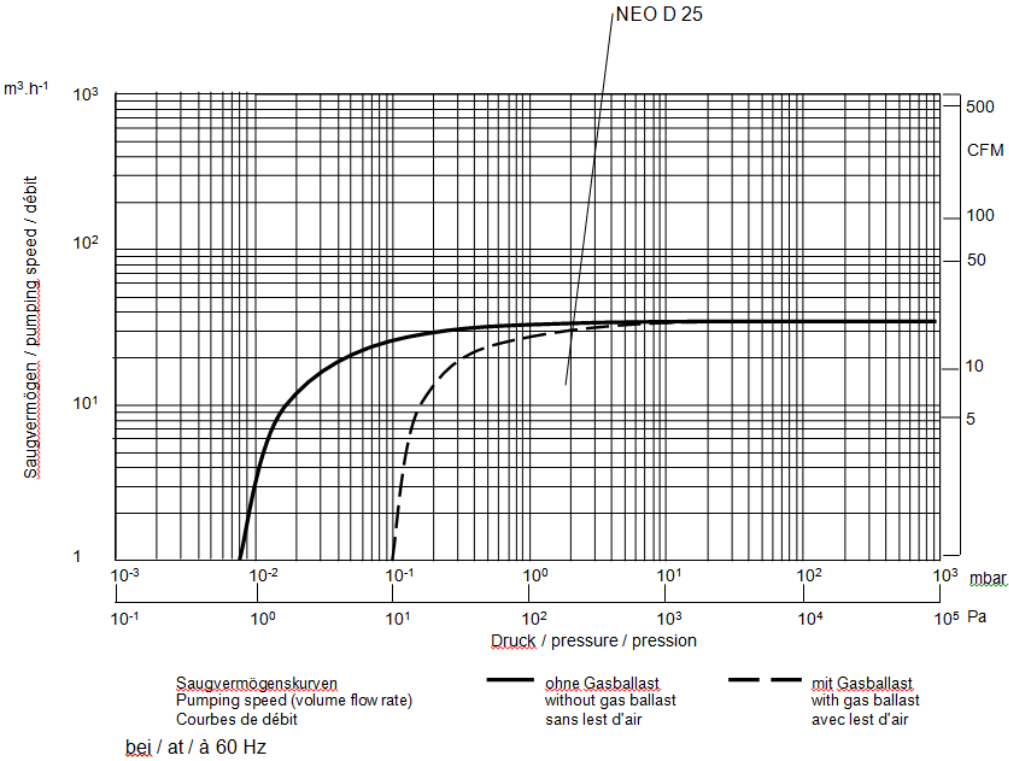

NEO D 40 Pumping speed curve 50 Hz

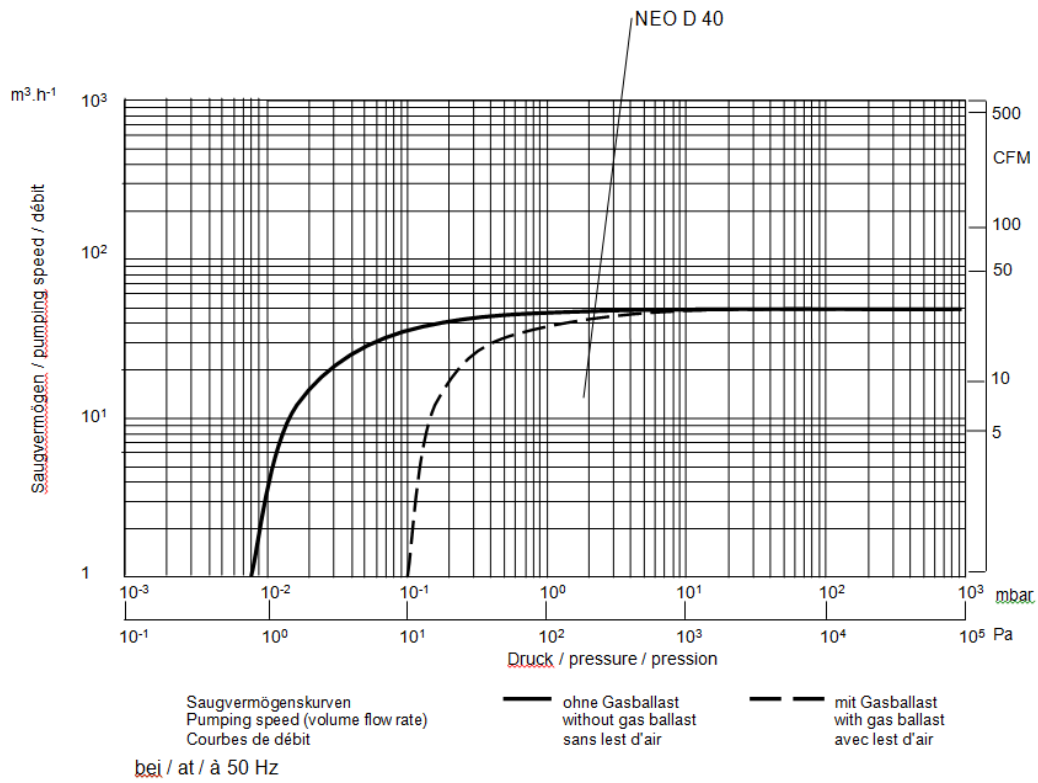

NEO D 40 Pumping speed curve 60 Hz

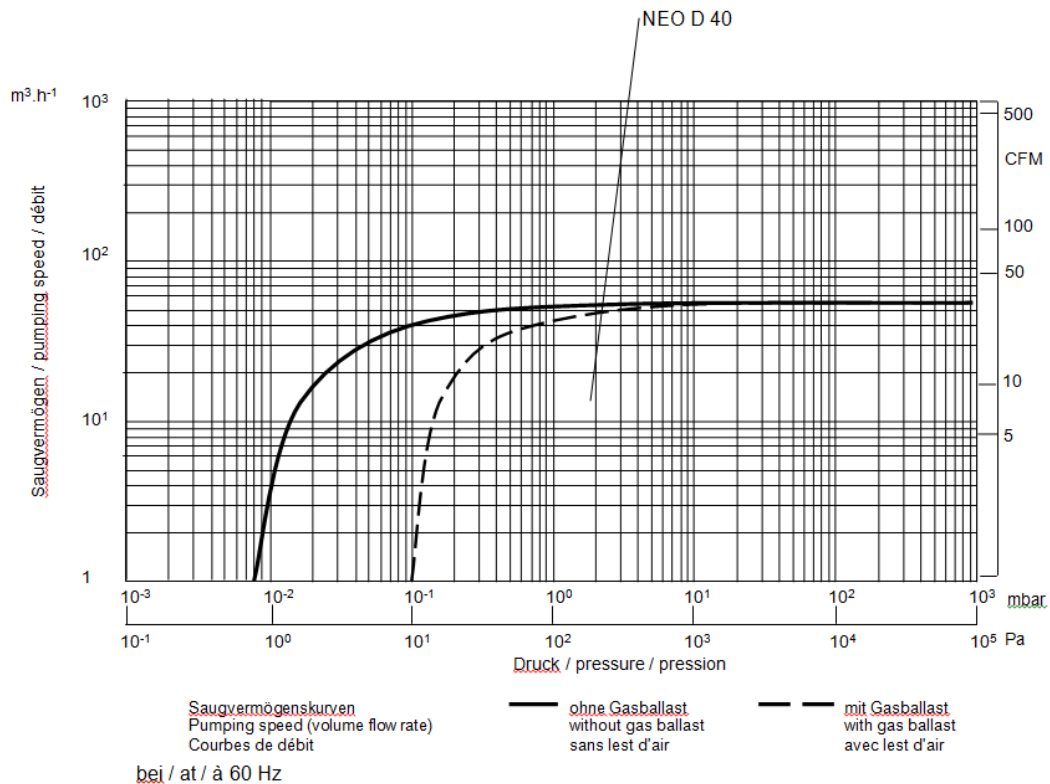

NEO D 65 Pumping speed curve 50 Hz

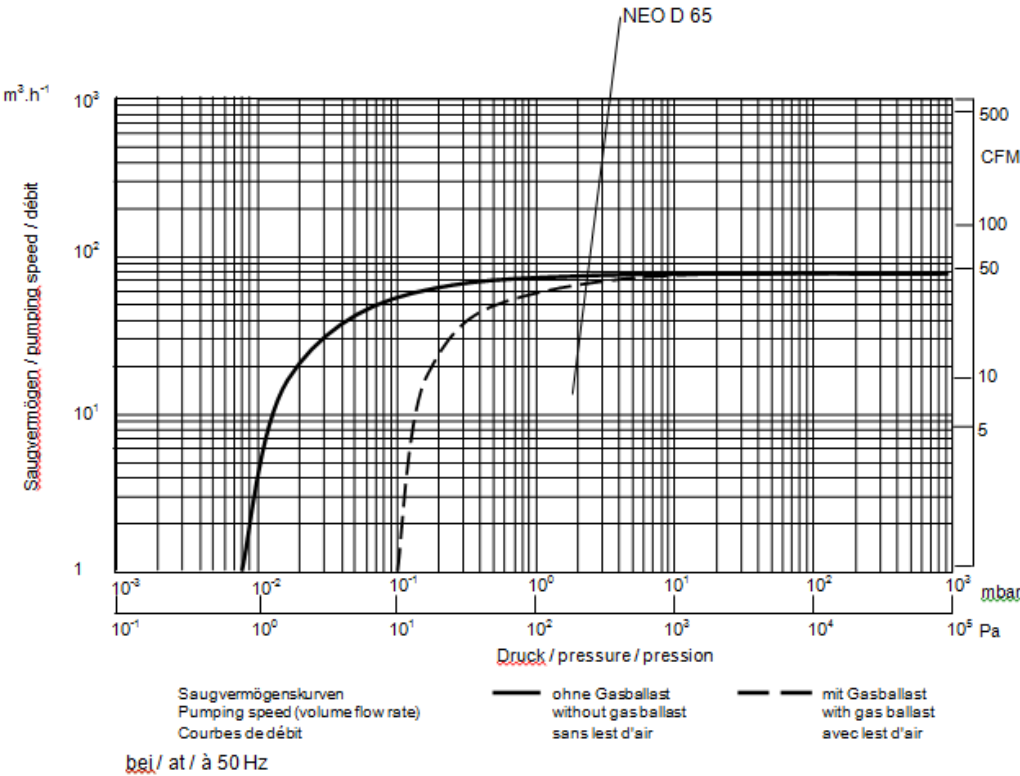

NEO D 65 Pumping speed curve 60 Hz

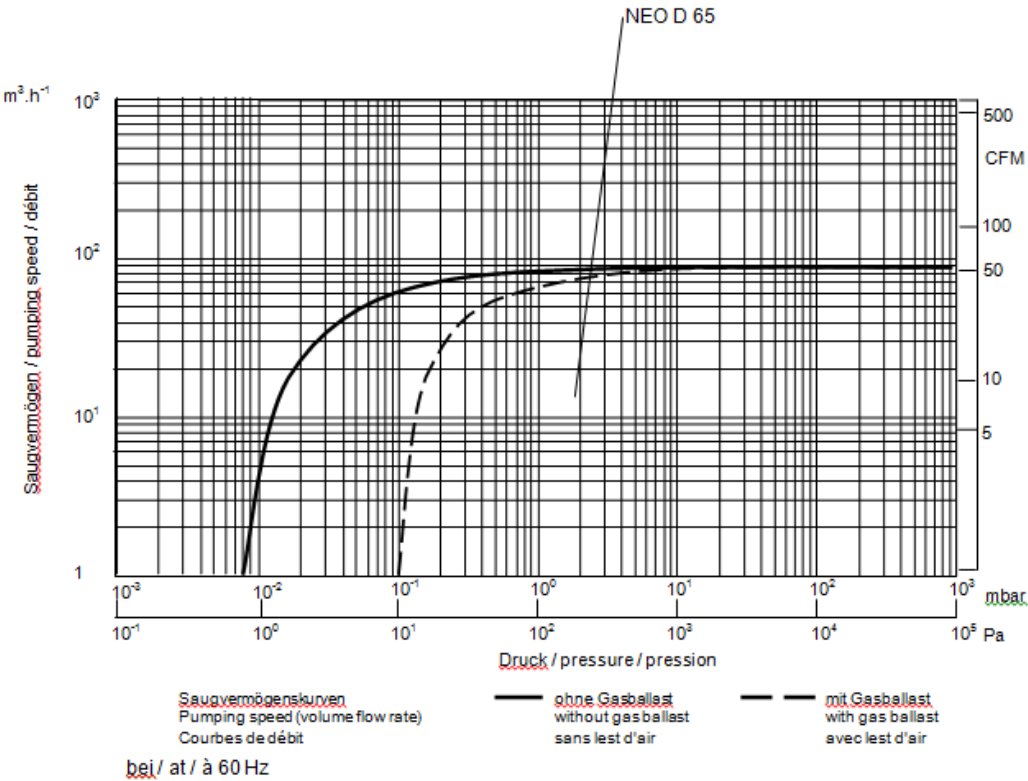

Ordering Information

1.3 Ordering Information

P/N	Pump Pompe Pumpe	Motor	GB	Oil filter Filtre huile Ölfilter	Oil Huile Öl	Inlet flange Bride aspi Einlass	Exhaust flange Bride refoul Auslass	Mains socket type Prise alim Leistungsstecker	On Off switch
970100V	NEO D 16	A	std	Y	LVO 700	25 KF	25 KF	C14	Y
970100V4100	NEO D 16	A	P	Y	LVO 700	25 KF	25 KF	C14	Y
970100V4200	NEO D 16	A	EM	Y	LVO 700	25 KF	25 KF	C14	Y
970100V4010	NEO D 16	A	std	Y	LVO 100	25 KF	25 KF	C14	Y
970100V4020	NEO D 16	A	std	Y	LVO 120	25 KF	25 KF	C14	Y
970100V4030	NEO D 16	A	std	Y	LVO 700	25 KF	25 KF	C14	Y
970100V4040	NEO D 16	A	std	N	LVO 420	25 KF	25 KF	C14	Y
970100V4050	NEO D 16	A	std	Y	LVO 140	25 KF	25 KF	C14	Y
970102V	NEO D 16	D	std	Y	LVO 700	25 KF	25 KF	-	-
970102V4100	NEO D 16	D	P	Y	LVO 700	25 KF	25 KF	-	-
970102V4200	NEO D 16	D	EM	Y	LVO 700	25 KF	25 KF	-	-
970102V4010	NEO D 16	D	std	Y	LVO 100	25 KF	25 KF	-	-
970102V4020	NEO D 16	D	std	Y	LVO 120	25 KF	25 KF	-	-
970102V4030	NEO D 16	D	std	Y	LVO 700	25 KF	25 KF	-	-
970103V	NEO D 16	B	std	Y	LVO 700	25 KF	25 KF	C14	Y
970103V4050	NEO D 16	B	std	Y	LVO 140	25 KF	25 KF	C14	Y
970123V4150	NEO D 16	B	P	Y	LVO 140	³ / ₄ " male JIC	25 KF	C14	Y

Motors

A = single phase wide range 200 ... 240 V +- 10 % 50 & 60 Hz

B = single phase low voltage 115 V +- 10 % 60 Hz

D = Three phase wide range 180...264 / 342...457 V, 50 Hz & 180...264 / 342...506 V, 60 Hz

Gas ballast

std = 3 positions (OFF/1/2)

P = permanent

EM = electromagnetic

N = no gas ballast

Oil filter

Y = Yes

N = No

Ordering Information

P/N	Pump Pompe Pumpe	Motor	GB	Oil filter Filtre huile Ölfilter	Oil Huile Öl	Inlet flange Bride aspi Einlass	Exhaust flange Bride refoul Auslass	Mains socket type Prise alim Leistungsstecker	On Off switch
970200V	NEO D 25	A	std	Y	LVO 700	25 KF	25 KF	C14	Y
970200V4100	NEO D 25	A	P	Y	LVO 700	25 KF	25 KF	C14	Y
970200V4200	NEO D 25	A	EM	Y	LVO 700	25 KF	25 KF	C14	Y
970200V4010	NEO D 25	A	std	Y	LVO 100	25 KF	25 KF	C14	Y
970200V4020	NEO D 25	A	std	Y	LVO 120	25 KF	25 KF	C14	Y
970200V4030	NEO D 25	A	std	Y	LVO 700	25 KF	25 KF	C14	Y
970200V4040	NEO D 25	A	std	N	LVO 420	25 KF	25 KF	C14	Y
970202V	NEO D 25	D	std	Y	LVO 700	25 KF	25 KF	-	-
970202V4100	NEO D 25	D	P	Y	LVO 700	25 KF	25 KF	-	-
970202V4200	NEO D 25	D	EM	Y	LVO 700	25 KF	25 KF	-	-
970202V4010	NEO D 25	D	std	Y	LVO 100	25 KF	25 KF	-	-
970202V4020	NEO D 25	D	std	Y	LVO 120	25 KF	25 KF	-	-
970202V4030	NEO D 25	D	std	Y	LVO 700	25 KF	25 KF	-	-
970202V4040	NEO D 25	D	std	N	LVO 420	25 KF	25 KF	-	-

Motors

A = single phase wide range 200 ... 240 V +- 10 % 50 & 60 Hz

D = Three phase wide range 180...264 / 342...457 V, 50 Hz & 180...264 / 342...506 V, 60 Hz

Gas ballast

std = 3 positions (OFF/1/2)

P = permanent

EM = electromagnetic

N = no gas ballast

Oil filter

Y = Yes

N = No

Ordering Information

P/N	Pump Pompe Pumpe	Motor	GB	Oil filter Filtre huile Ölfilter	Oil Huile Öl	Inlet flange Bride aspi Einlass	Exhaust flange Bride refoul Auslass	Mains socket type Prise alim Leistungsstecker	On Off switch
970300V	NEO D 40	A	std	Y	LVO 700	40 KF	40 KF	C20	Y
970300V4200	NEO D 40	A	EM	Y	LVO 700	40 KF	40 KF	C20	Y
970300V4020	NEO D 40	A	std	Y	LVO 120	40 KF	40 KF	C20	Y
970300V4030	NEO D 40	A	std	Y	LVO 700	40 KF	40 KF	C20	Y
970300V4040	NEO D 40	A	std	N	LVO 420	40 KF	40 KF	C20	Y
970302V	NEO D 40	D	std	Y	LVO 700	40 KF	40 KF	-	-
970302V4100	NEO D 40	D	P	Y	LVO 700	40 KF	40 KF	-	-
970302V4200	NEO D 40	D	EM	Y	LVO 700	40 KF	40 KF	-	-
970302V4010	NEO D 40	D	std	Y	LVO 100	40 KF	40 KF	-	-
970302V4020	NEO D 40	D	std	Y	LVO 120	40 KF	40 KF	-	-
970302V4030	NEO D 40	D	std	Y	LVO 700	40 KF	40 KF	-	-
970302V4040	NEO D 40	D	std	N	LVO 420	40 KF	40 KF	-	-

Motors

A = single phase wide range 200 ... 240 V +- 10 % 50 & 60 Hz

D = Three phase wide range 180...264 / 342...457 V, 50 Hz & 180...264 / 342...506 V, 60 Hz

Gas ballast

std = 3 positions (OFF/1/2)

P = permanent

EM = electromagnetic

N = no gas ballast

Oil filter

Y = Yes

N = No

Ordering Information

P/N	Pump Pompe Pumpe	Motor	GB	Oil filter Filtre huile Ölfilter	Oil Huile Öl	Inlet flange Bride aspi Einlass	Exhaust flange Bride refoul Auslass	Mains socket type Prise alim Leistungsstecker	On Off switch
970402V	NEO D 65	D	std	Y	LVO 700	40 KF	40 KF	-	-
970402V4100	NEO D 65	D	P	Y	LVO 700	40 KF	40 KF	-	-
970402V4200	NEO D 65	D	EM	Y	LVO 700	40 KF	40 KF	-	-
970402V4010	NEO D 65	D	std	Y	LVO 100	40 KF	40 KF	-	-
970402V4020	NEO D 65	D	std	Y	LVO 120	40 KF	40 KF	-	-
970402V4030	NEO D 65	D	std	Y	LVO 700	40 KF	40 KF	-	-
970402V4040	NEO D 65	D	std	N	LVO 420	40 KF	40 KF	-	-

Motors

D = Three phase wide range 180...264 / 342...457 V, 50 Hz & 180...264 / 342...506 V, 60 Hz

Gas ballast

std = 3 positions (OFF/1/2)

P = permanent

EM = electromagnetic

N = no gas ballast

Oil filter

Y = Yes

N = No

Ordering Information

1.3 Ordering Information ATEX

Size	Part-Nr.	Inside temp. class	Outside temp. class	Inside gas group	Outside gas group	ATEX Marking 
SV Neo D 16	970102A33	160°C	T3	IIC	IIC	Ex II (i) 3 G h IIC 160°C Gc (10 <Ta< 40°C) X / (o) 3 G IIC T3 Gc (10 <Ta< 40°C) X
SV Neo D 16	970102SD A30V01	160°C	---	IIC	---	Ex II (i) 3 G h IIC 160°C Gc (10 <Ta< 40°C) X
SV Neo D 25	970202A33	160°C	T3	IIC	IIC	Ex II (i) 3 G h IIC 160°C Gc (10 <Ta< 40°C) X / (o) 3 G IIC T3 Gc (10 <Ta< 40°C) X
SV Neo D 40	970302A33	160°C	T3	IIC	IIC	Ex II (i) 3 G h IIC 160°C Gc (10 <Ta< 40°C) X / (o) 3 G IIC T3 Gc (10 <Ta< 40°C) X
SV Neo D 65	970402A33	T3	T3	IIC	IIC	Ex II (i) 3 G h IIC T3 Gc (10 <Ta< 40°C) X / (o) 3 G IIC T3 Gc (10 <Ta< 40°C) X

Explanation of Symbols

- II Equipment group II refers to equipment intended for use in places other than mines likely to be endangered by explosive atmospheres.
- (i)/(o) Specifies the category / conditions for which the inside (i) (i.e. the parts of the apparatus in contact with the process gas stream) and the outside (o) of the apparatus are certified when different.
- 3 Category 3 comprises equipment designed to be capable of functioning in conformity with the operating parameters established by the manufacturer and ensuring a normal level of protection. Equipment in this category is intended for use in areas in which explosive atmospheres caused by gases, vapors, mists, or air/dust mixtures are unlikely to occur or, if they do occur, are likely to do so only infrequently and for a short period only. Equipment in this category ensures the requisite level of protection during normal operation.
- G Explosive atmosphere is caused solely by gases, vapors or mists in air
- II, IIA, IIB, or IIC Explosion groups: These are subdivisions of equipment of Group II used for some specific types of protection. This classification is based on the maximum experimental safe gap and the minimum ignition current of the explosive mixture. See Annex A of the European standard EN 50014. (EN 50014 Electrical apparatus for potentially explosive atmospheres - General Requirements)
NOTE: Equipment marked IIB is suitable for applications requiring IIA equipment. Similarly, equipment marked IIC is suitable for applications requiring IIA or IIB equipment. Equipment suitable for all applications may also be marked II or not marked.
- T3 Temperature Class: Classification of equipment into classes depending on their maximum surface temperature according to the following table:

Temperature class	Maximum surface temperature (°C)
T1	450
T2	300
T3	200
T4	135
T5	100
T6	85

Ordering Information

NOTE. The Temperature Class and the actual maximum surface temperature of the equipment includes the safety margin to the minimum ignition temperature of the potentially explosive atmosphere as required in EN 1127-1

- Ta Allowable ambient temperature for use of the pump $10^{\circ}\text{C} < T_a < 40^{\circ}\text{C}$
- X Special operating conditions for safe use apply - see information given in this manual

Ordering information

1.4 Accessories

Description	Part-Nr.
1 Oil level switch	9700LS
2 Exhaust filter pressure switch	971471210
3 Exhaust filter pressure manometer	95193
4 Temperature switch Pump sizes 16-25-40 Pump size 65	9700TS 9700TS65
5 PT100 on 40 & 65 sizes only	971444320
6 Gas ballast manual 3 flows Pump size 16-25 Pump size 40-65	EK6702808 EK6703081
6 Gas ballast manual 16 KF	9700GBA
6 Gas ballast permanent	9700GBP
6 Gas ballast permanent 16 KF	EK6702221
6 Gas ballast EM 24 V DC +- 10 %; 0.5 A	9700GBDC
Roots adapter up to WAU 501 for SV Neo D 65	970RA01
Roots adapter up to WAU 501 for SV Neo D 40	970RA02

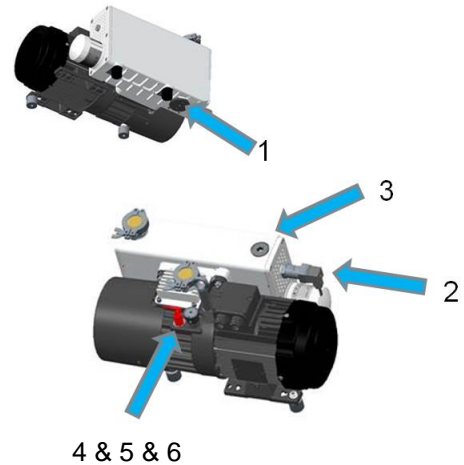

Stability of pump is insured with accessories of Leybold; mounting of any other accessory will engage the responsibility of user concerning stability of pump.

In case a direct Roots pump coupling is used, it is important to check the gas temperature due to the Roots compression.

Power cords

For single phase pump versions

P/N / Ref / Kat-Nr	Plug pump side	Plug supply side	Length m
141103US	C19	NEMA 5-15P 125 V	1.8
161810US	C19	NEMA 6-15P 250 V	1.8
161810EU	C19	Euro / Schuko 16 A	1.8
161810UK	C19	UK plug 13 A	1.8
E6500825	C19	C20	2.5
E6505883	C19	IEC 309 16 A	5
EK6502798	C19	C14	2.5
971443450	C13	Euro / Schuko 16 A	2
6534485V	C13	NEMA 5-15P 125 V	2
EK6508756	C13	NEMA 6-15P 250 V	2
9714434GB	C13	UK plug 13 A	2
9714434CH	C13	CH plug 10 A	2
9714434WW	C13	w/o	2
E6500255	C13	C14	2.5
EK6701862	C13	C20	0.2

SV Neo D 16 & 25 need C13 cables

SV Neo D 40 & 65 need C19 cables

The power cords are not included in the pump scope of delivery. We include a C14 resp. C20 plug.

Should non Leybold power cords be used, take below minimum cross sections:

Pump	115 V	230 V
SV Neo 16 / 25	AWG14 / 2 mm ²	AWG15 / 1,5 mm ²
SV Neo D 40 / 65	N/A	AWG14 / 2 mm ²

Ordering information

1.5 Spare parts

Description	SV Neo D 16	SV Neo D 25	SV Neo D 40	SV Neo D 65
Set of gaskets	EK9701SK	EK9702SK	EK9703SK	EK9704SK
Exhaust filter	EK6702228	EK6702158	EK6702490	EK6702425
Oil filter	EK96004	EK96004	EK96004	EK96004
Oil filter bypass	71230570	71230570	71230570	71230570
Maintenance kit	EK9701M	EK9702M	EK9703M	EK9704M
Repair kit	EK9701RES	EK9702RES	EK9703RES	EK9704RES
Generator kit	EK9701GEN	EK9702GEN	EK9703GEN	EK9704GEN

1.5 Spare parts ATEX pumps

Description	SV Neo D 16	SV Neo D 25	SV Neo D 40	SV Neo D 65
Set of gaskets	EK9701SK	EK9702SK	EK9703SK	EK9704SK
Exhaust filter	EK6703124	EK6703129	EK6703130	EK6703135
Oil filter	---	---	---	---
Oil filter bypass	71230570	71230570	71230570	71230570
Maintenance kit	EK9701AM	EK9702AM	EK9703AM	EK9704AM
Repair kit	EK9701ARES	EK9702ARES	EK9703ARES	EK9704ARES
Generator kit	EK9701GEN	EK9702GEN	EK9703GEN	EK9704GEN

Only original Leybold spare parts are to be used in the pumps. A non-respect of this will entail a loss of the pump's ATEX certification.

1.6 Lubricants

Only original Leybold oil are to be used in the pumps, at least during their warranty period.

Warning

Following oil types can be used depending of the pump P/N, see § 1.3 Ordering Information

- Mineral oil LVO100 / 120
- Food grade oil LVO140
- PFPE LVO420
- Long life oil LVO700



Oil volume oil can	Mineral oil LVO100	Mineral oil LVO120	Food grade oil LVO140	PFPE LVO420	Long life oil LVO700
	Part-Nr.	Part-Nr.	Part-Nr.	Part-Nr.	Part-Nr.
1 l	L10001	L12001	L14001	L42001	L70001
5 l	L10005	L12005			

Use only the oil type indicated on the pump for ATEX pumps.

Transport and Storing

2 Transport and Storing

2.1 Transport and packaging

SOGEVAC vacuum pumps pass a rigorous operating test in our factory and are packaged to avoid transport damages.

Please check packaging on delivery for transport damages. Outer packaging is made by a wood pallet & cardboard or wood top

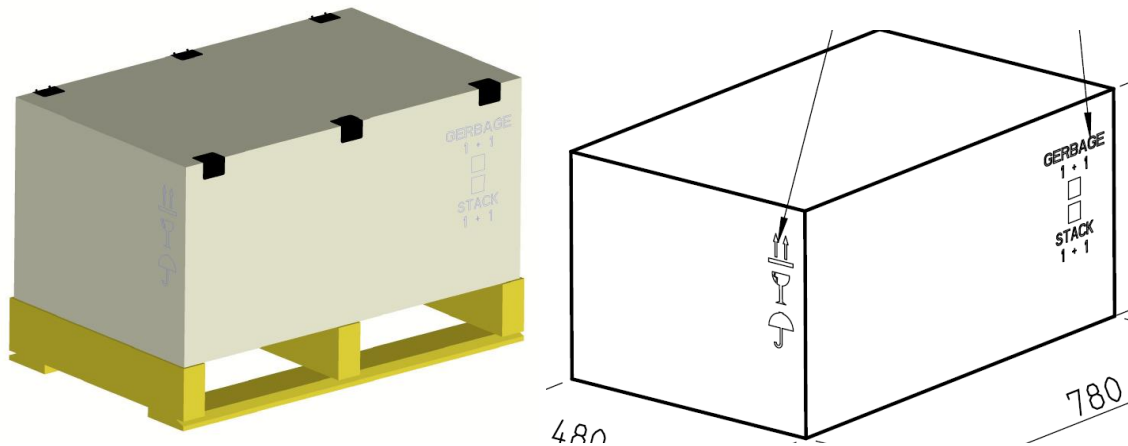

Pallets are to be handled with a forklift.

For unpacking,

- 1) Cut the 3 plastic straps carefully. Wear gloves & protection glasses!
- 2) Remove the cardboard top and inner reinforcement cardboard belt or wood box.

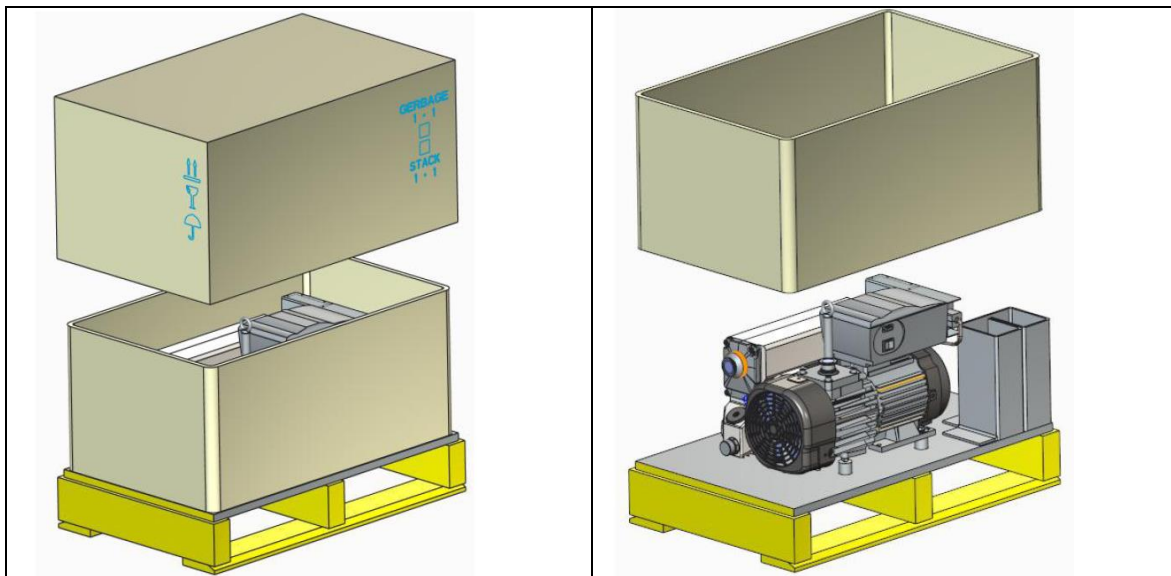

Transport and Storing

Pump fixation

The pumps are bolted by screws. Screws are to be removed from under the pallet using a 13 mm wrench.

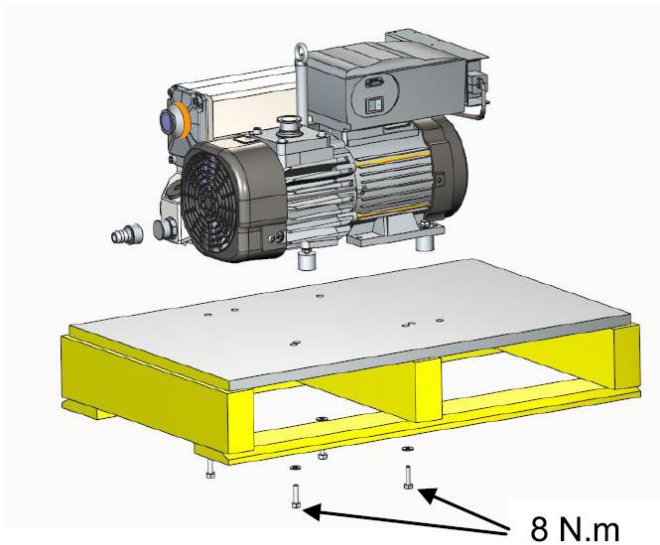

Pump lifting

The pump is then ready to be shifted or lifted off the pallet.



Due to the pump weight ONLY a suitable lifting device shall be used to lift the pump at the lifting lug (CE regulations) A lifting device is the only officially recommended way of handling the pump.

Do not lift at the motor, frequency converter, cables connection boxes, flanges etc.! Do not drag the pump from these points.

Packing materials should be disposed of according to environmental laws or re-cycled. These operating instructions are part of the consignment. The connection ports are blanked off by plastic or metallic protective caps.

Take these caps away before turning on the pump. A sticker showing the steps is delivered with every pump. Please follow these instructions.

The pumps have their oil filled in.

Transport and Storing

2.2 Mounting orientation

See required space on drawings in paragraph 1.2.

Pumps which have been filled with oil must only be moved in the upright position (horizontally). Otherwise oil may escape. The angle of slope may not be over 10° max. Avoid any other orientations while moving the pump. Check the pump for the presence of any oil leaks, because there is the danger that someone may slip on the oil which has leaked from the pump. Only use the lifting lugs which are provided on the pump to lift the pump with the specified lifting devices.

Make sure that these have been installed safety. Use suitable lifting equipment. Make sure that all safety regulations are observed. Use only lifting devices appropriated to the pump weight. Check name plate. Do not use other pump elements than the lifting lugs as handles.

Caution

2.3 Storage

Before stocking the pump for a long time put it back in its original condition (blank off inlet and exhaust ports with the shipping seals, drain the oil) and store the pump in a dry place at room temperature.

Caution

Storage temperature: - 15°C to + 50°C

Until the pump is put back in to service again, the pump should be stored in a dry place, preferably at room temperature (20 °C - 168 °F). Before taking the pump out of service, it should be properly disconnected from the vacuum system, purged with dry nitrogen and the oil should be exchange too. The inlet and exhaust ports of the pump must be blanked off using the shipping seals which are included upon delivery of the pump.

The gas ballast must be closed and if the pump is to be shelved for a longer period of time is should be sealed in a plastic bag together with a desiccant (Silicagel).

If the pump has been shelved for over one-year, standard maintenance must be done, and the oil must be exchanged too before the pump is put into service once more.

We recommend that you contact the service from Leybold.

Installation

3 Installation

It is essential to observe the following instructions step by step to ensure safe start-up.

Before installing the pump, you must reliably disconnect it from the electrical power supply and prevent the pump from running up inadvertently.

Observe all safety regulations.

Do not stand on the pump and do not place objects on the pump as these can cause deformation of the fan housing and possible frictional rubbing.

Warning



3.1 Installation

The SOGEVAC can be set up on any flat, horizontal surface. Under the four feet, there are metric threaded holes (see § 1.2 Connection) for securing the pump.

The oil level cannot be read properly if the pump is tilted and lubrication may be affected. The max. slope angle is $\pm 1^\circ$.

The pump's ambient temperature must be between 12°C (55°F) and 40°C (104°F). Additional warning note: consider changes in ambient temperatures that might occur when air conditioning is turned down, such as nights and weekends.

Warning



The following ambient operating environment must be observed:

- Pollution degree 2
- Ambient pressure = Atmospheric pressure.
- Rel. humidity $\leq 95\%$ without condensation

Normal presence of transient over-voltages due to the power mains.

NOTE: the usual transient over-voltage level corresponds to the category II of the impulse withstand (over-voltage) of the IEC 60364-4-443.

To ensure adequate cooling of the pump, leave enough space at the air intake and exhaust points, and for access and maintenance (see Fig. 1.1 to 1.4). Make sure to keep the fans, hoods, cooling coils & air intake of the motor clean. The pump must be kept clean (no dust deposit). The pump is to be installed such that the oil level sight-glass can be both easily read and so that it will not be broken.

The pumps are delivered with closed gas ballast.

3.2 Connection to the system

Intake Side

Caution

- Pump should be connected to inlet line without any tension. Use flex lines or pipe unions in your inlet and exhaust lines so that they can be easily removed for pump maintenance.
- The maximum pressure at the inlet may not exceed atmospheric pressure (about 1013 mbar). Never operate the pump in the presence of over pressures at its intake.
- Type of materials used for mounting of pipings should take care of pumped gases regulations. It is the same for its tightness. Using suitable connecting elements, the pump can be connected to the vacuum system.

The cross-section of the intake line should be at least the same as the one for the intake port. If the intake line is too narrow, it reduces the pumping speed. If the process gas contains dust, it is essential to install a dust filter in addition to the dirt trap supplied.

We recommend installing the dust filter horizontally. This ensures that when removing the filter, no particles fall into the intake port.

When pumping vapors, we recommend installing condensate traps on the intake and exhaust sides.

The intake must be installed in such a way to avoid condensates flowing into the pump.

Exhaust Side

Caution

The SOGEVAC pumps have integrated exhaust filters which, even at a high gas throughput, trap the oil mist and guarantee exhaust gas free of oil mist. If the exhaust filters are clogged, the bypass opens at 1.5 bar, (absolute pressure), and the filters are bypassed. As a result, the proportion of oil in the exhaust gas as well as the pump's oil consumption will rise. Installing new exhaust filters will correct this problem. (See § 5.4).

Check in the individual case whether a line is necessary and/or prescribed.

Volatile substances will pass through the filter. Depending on the process gas, we recommend connecting an exhaust line; this is always necessary when the exhaust gases are dangerous.

The maximum exhaust pressure must neither exceed 1.15 bar absolute (0.15 bar relative), nor fall under atmosphere pressure minus 15 mbar. Pump exhaust to be connected if oil mist or process gases are to be avoided in the pump area.

Corresponding pressure regulating devices to be installed by the user.

The cross-section of the exhaust line should be at least the same as the pump's exhaust port. If the exhaust line is too narrow, overpressure or overheating may occur in the pump.

Before installing the exhaust line, remove the exhaust-flange plate and ensure that the exhaust demister(s) are secured tightly in place. They sometimes loosen during shipping and installation. A loose demister results in exhaust smoke during start-up and operation. Install the exhaust line with a downward slope to prevent condensate from flowing back into the pump. If this is not possible, we strongly recommend installing a condensate trap.

Warning



Never operate the pump with a blocked or restricted exhaust line. Before start-up, ensure that any blinds or similar shut-off devices in the exhaust line on the pressure side are opened and that the exhaust line is not obstructed. Exhaust pipe material must be resistant to pumped gases. Use conductive materials for the exhaust pipe to avoid electrostatic charges.

Installation

3.3 Electrical connections

Ensure that incoming power to the pump is off before wiring the motor or altering the wiring. The specific wiring and instructions for installation given in the manual for the electric motor must be followed.

The pump shall be adequately earthed to prevent the accumulation of static electricity. The electrical junction box should only be opened, and electrical connections made when no explosive atmosphere is present.

Warning



3 phase motors

For connecting the motor, follow the schematics provided on the motor name plate or in its junction box, given your local mains voltage & frequency.

Electrical connection work must only be carried out by a qualified electrician in accordance with the applicable safety rules, see IEC 60204-1 & 61010-1.

Connect the pump's motor to the right supply voltage via the connections in the junction box. The relevant safety rules require the use of a suitable motor protection switch. Set the switch in accordance with the rating on the motor nameplate.

If any security switch or electrical defect cuts out the pump, re-start-up of the pump must be possible only manually.

Ensure that incoming power to the pump is off before wiring the motor or altering the wiring. The specific wiring and instructions for installation in potentially explosive atmospheres given in the manual for the electric motor must be followed. Additional information can be found in the European Standard EN 60079-14 Electrical apparatus for explosive gas atmospheres Part 14 Equipment for use in potentially explosive gas atmospheres and EN 60079-17 Electrical apparatus for explosive gas atmospheres Part 17.

Warning



The use of frequency converters to control the SOGEVAC ATEX Cat. 3 pumps is not allowed.

The pump shall be adequately earthed to prevent the accumulation of static electricity. The electrical junction box should only be opened, and electrical connections made when no explosive atmosphere is present.

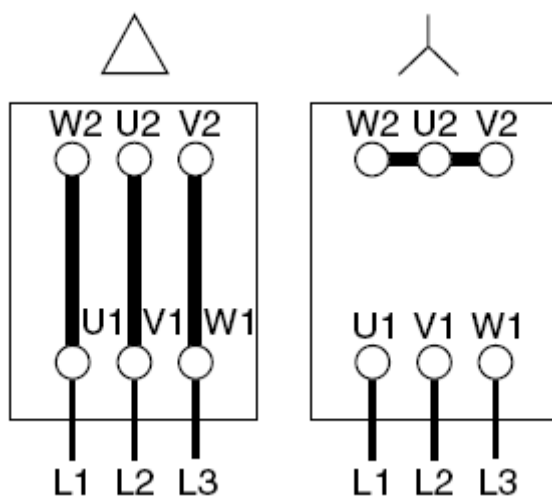

Low voltage connection

High voltage connection

Installation

The pump is designed for direct starting even under load conditions, i.e. the pump can be switched on against vacuum in the intake port.

After connecting the motor and after every time you alter the wiring, check the direction of rotation. Refer to the arrow marked on the generator fan cover center and on the motor cover:



During the check, the intake port should be open. If the direction of rotation is wrong, oil may be ejected out the intake port. (The vacuum system may be pressurized).

For the check, switch on the motor briefly. If it starts up with the wrong direction of rotation, switch it off immediately and interchange two phases of the connection. It is recommendable to check the direction of rotation with a phase sequence indicator.

Prolonged running of the motor in the wrong direction of rotation will damage the pump!

1 phase motors

Should the pump be connected to a standard wall socket, it must be checked that a building protection rated 16 A is installed (fuse or breaker curve B) to protect the power cable. Even if the pump is not operating, live voltage is present in the connection box! Voltage and frequency mentioned on the pump nameplate must agree with the supply voltage. The control cable must be at least distant by 10 cm to the mains cable and crossings shall be at 90°. The power socket and cord are disconnection elements which must remain accessible to the users.

The motor integrates a motor over-load protection device (red knob on motor connection box) to be manually reset after an overload trip.



Frequency converter

Should the pump be connected to a standard wall socket, it must be checked that a building protection rated 16 A is installed (fuse or breaker) to protect the power cable. The frequency converter itself is self-protecting. Voltage and frequency mentioned on the pump nameplate must agree with the supply voltage. Even if the pump is not operating, live voltage is present in the frequency converter! The control cable must be at least distant by 10 cm to the mains cable and crossings shall be at 90°. The power socket and cord are disconnection elements which must remain accessible to the users.

The pump is protected against over-currents by two 5X20 mm internal fuses rated 250 V, 16 A Time lag T. The fuse is mounted in a separate housing and can be exchanged from outside using a screwdriver to open the fuse holder cap. See drawing below.

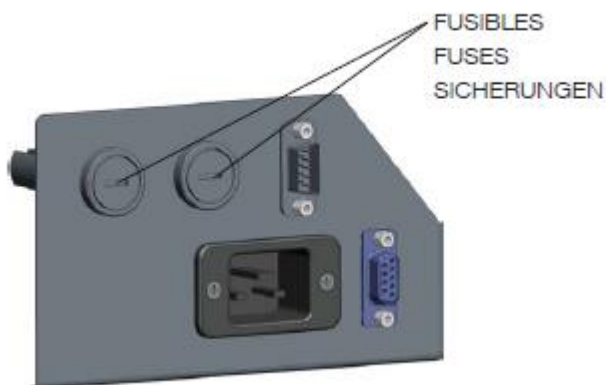

Exchange fuse only with electrically unplugged pump.

Temperature Switch (on given variants only)

A temperature switch can be retrofitted on the pumps and is available as an accessory. It is a dry contact normally closed, tripping at

- Pumps sizes 16-25-40 : 100 °C.
- Pumps size 65 : 115 °C

Hysteresis 15 to 20 °C

The thermal switch can be connected in series with the motor protection relay.

Switching ratings DC 3A/60V Max
 AC 5A/25V Max

Make sure the pump restart will be possible only by a voluntary action after having solved the overheating cause.

Temperature Sensor PT100 (on given variants only)

A temperature sensor type PT100 can be placed on the vacuum generator close to the exhaust valves. The temperature sensor monitors the pump temperature. See above paragraph Thermal switch for threshold values.

Make sure the pump restart will be possible only by a voluntary action after having solved the overheating cause.

Oil level Switch (on given variants only)

An oil level switch can be retrofitted on the pumps and is available as an accessory. The pump must be switched off and the pump and oil level checked immediately if the oil level is too low.

To avoid false alarms, it is recommended to use a timer of 20 seconds on the switch output. If the default remains longer than 20 seconds, the pump must be switched off.

Switching ratings	DC 1A/60V Max AC 0,5A/25V Max
-------------------	----------------------------------

Exhaust filter over pressure switch (on given variants only)

An overpressure switch can be retrofitted on the pumps and is available as an accessory. The pump must be switched off and the pump, exhaust line and exhaust filters checked or changed immediately if the pressure in the oil casing is too high.

To avoid false alarms (e.g. at cold pump start) it is recommended using a timer set to 20 seconds on the switch output.

The exhaust filter switch warns when the increase in pressure drop over a filter caused by gradual clogging becomes too high, by means of an electrical alarm indication.

Attention: this only works at high inlet pressure (ideally atmospheric pressure at the inlet)!

Switching ratings	DC 1A/60V Max AC 0,5A/25V Max
-------------------	----------------------------------

See next page for threshold values.

Associated Electrical equipment

The electrical equipment supplied with this pump e.g. motor, valves, sensors etc. are also suitable for use in potentially explosive gas / dust atmospheres under the same conditions as those for the pump. The instructions given in the electrical motor manufacturer's Information for Use attached to this manual must be complied with. The electrical motor and accessories meet the IP65 enclosure requirements or their equivalent.

The ignition protection sensors (over-temperature, outlet-pressure, oil-level) must be used to protect the pump against critical operational parameters and must be configured to cause shut of the pump if the values go outside of the allowable range. Additionally, the Temperature and pressure measurements should be configured to be fail safe i.e. loss of signal from the sensor should cause the pump to shut down.

Restart should not be possible without re-setting of the ignition preventing system. The system should meet requirements of IPL1 (EN13463-6) equivalent to SIL1 (EN 61508) or EN 954-1.

Installation

3.4 Start-up

Control Parameters for the Ignition Prevention System (ATEX variants)

Caution

Option	Temperature switch	Temperature Sensor PT100	Oil Casing Pressure Switch	Oil Level Switch
Alarm Value	N/A	90 °C	N/A	N/A
Pump Stop Value and Timer	100 °C At switching Immediately	100 °C Immediately	At switching After 20 s	At switching After 20 s

During cold start up the pressure in the oil casing can rise momentarily to above 650 mbar due to the oil filters being temporarily blocked by oil. In order to prevent an inadvertent shut-off of the pump the pressure sensor control system should include a delay such that the pressure must be above 650 mbar for 15 s before the pump is switched off.

Caution

If the pressure in the oil casing rises above 1 bar overpressure the pump should be immediately switched off as this indicated that the outlet is blocked.

The noise level can be higher at pump cold start, especially with oil having a viscosity grade > ISO VG 68 (e.g. LVO100). The noise level normalizes itself once the pump warms up after a few minutes.

The oil for the first filling is supplied with the pump. Before switching on, always make sure that the pump contains enough oil. The normal oil level in a still standing pump is in the upper half of the sight glass. If oil must be added, unscrew the oil-fill plug, add oil and screw the plug firmly back in.

The SOGEVAC is designed for normal start-up at temperatures over 12°C (54°F) (as per PNEUROP).

Before starting the pump ensure that the attached accessories meet the requirements of your application and that safe operation is ensured.

Never expose part of the body to the vacuum. Do not lay the hand on the intake to check suction. Exposure of a part of the body to the vacuum result in a rush of blood in the exposed part.

There is a danger of injury. Never operate the pump with an open and thus accessible inlet.

Vacuum connections as well as oil filling and oil draining openings must not be opened during operation of the pump.

The safety regulations which apply to the specific application in each case must be observed. This applies to installation, operation and maintenance (servicing) as well as waste disposal and transportation.

Warning



Operation

4 Operation

4.1 Operation

To avoid overloading the motor, do not start the pump more than six times within one hour. If frequent starts are needed, the pump shall run continuously and be linked to the vacuum vessel by means of a valve. In that case, regulation will be made by the valve and not by start/stop of the pump. With the valve closed, the pump consumes little energy.

The SOGEVAC can pump gases and vapors, provided that the gas ballast valve is installed and open and the pump has reached its operating temperature.

Pump in function is hot and some surfaces could reach a temperature higher than 80°C (176°F). There is a risk of burn by touching. Take note of warning labels on the pump.

Wear ear protection in case of operation at high inlet pressure!

Pumping of non-condensable gases

If the pump system contains mainly non-condensable gases, the pump should be operated without gas ballast.

If the composition of the gases to be pumped is not known and if condensation in the pump cannot be ruled out, run the pump with gas ballast valve open in accordance with section below.

Pumping of condensable gases and vapors

With the gas ballast valve open and at operating temperature, the SOGEVAC can pump pure water vapor up to the values indicated in the Technical Data.

The gas ballast valve is operated manually by turning the rubber knob on the gas ballast head. There are 3 positions:

O closed

I small flow for small vapor quantities and

II standard flow for standard vapor quantities

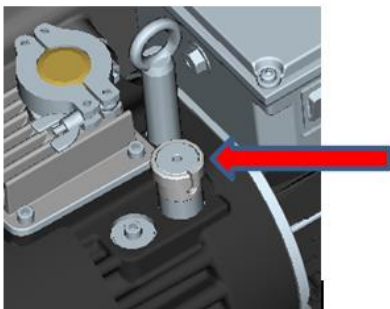

The running noise of the pump is slightly louder if the gas ballast valve is open. Before pumping vapors ensure that the pump has warmed up for approx. 30 min. with closed intake line and with open gas ballast valve.

Don't open the pump to condensable vapors until it has warmed to operating temperature: pumping process gas with a cold pump results in vapors condensing in the oil.

For processes with a high proportion of condensable vapors, the intake line should be opened only slowly after reaching the operating temperature. One sign of condensation of vapors in the pump is a rise of the oil level during operation of the pump.

Warning



Caution

Operation

When vapors are pumped, the pump must not be switched off immediately after completion of the process because the condensate dissolved in the pump oil may cause changes or corrosion. To prevent this, the pump must continue to operate with open gas ballast valve and closed intake port until the oil is free of condensate. We recommend operating the pump in this mode for at least 30 min. after completion of the process.

In cycle operation, the pump should not be switched off between the cycles but should continue to run with gas ballast valve open and intake port closed (if possible, via a valve). Power consumption is minimal when the pump is operating at ultimate pressure.

Once all vapors have been pumped off from a process (e. g. during drying), the gas ballast valve can be closed in order to improve the ultimate pressure.

If ATEX gases are pumped, it is mandatory to use an inert GB gas supply through the DN16 KF connection. The GB air filter is to be used only if no ATEX gases are pumped.

The SOGEVAC Neo D can be equipped with different types of gas ballasts, as defined by their cat-nr.

The GB flow is valid for a pump operating at ultimate pressure (inlet closed) and for a GB gas supply of 1 bar abs. GB gas supply pressure max. 1 bar abs.

In case an EM gas ballast is used, it must be supplied with 24 V DC +- 10 %; 0.5 A min.

Caution

Warning



In normal operation, the Sogevac Neo D pumps operated typically below 10 mbar inlet pressure or at ultimate pressure with open gas ballast (for pumps having a gas ballast). Continuous duty and cycling operation are of course possible.

In the below listed abnormal conditions (but not limited to) the pump may stop due to overheating of the power electronics or motor.

- Continuous operation at high inlet pressure
- Restricted, clogged or blocked exhaust filters or exhaust line
- Out of tolerance supply voltage
- Unsuitable, polluted or too old oil
- Too low oil level
- Too high ambient temperature
- Clogged fan hoods or impeded fresh air circulation
- Etc.

The pump has been designed & tested to work in a normal EMC environment in acc. to IEC 61326-1 Table 1

Operation

4.2 Shutdown

Under normal circumstances, all that you need do is to switch off the pump. The intake port of the SOGEVAC contains an anti-suck back valve, which closes the intake port when the pump is shut down, to avoid the pump oil being sucked back into the vacuum chamber. The valve's functioning is not impaired by gas ballasting. The anti-suck back valve is not a safety vacuum valve. When pumping condensable media, let the pump continue to operate with the gas ballast valve open and the intake line closed before switching off.

Warning



If the pump is to be shut down for an extended period or if the pump must be stored, proceed as follows: When pumping harmful substances, take adequate safety precautions.

Drain the oil (see Section 5.4).

Pour in clean oil up to the bottom edge of the oil-level glass (see Section 5.4) and let the pump run for a few minutes.

Then drain the oil and pour in clean oil up to the top edge of the oil-level glass (see Section 5.4).

Seal the connection ports. Special preservation or flushing oils are not necessary.

When the pump has been switched off due to over-heating, initiated by the motor or its protection, the pump must be cooled down to the ambient temperature and must only be switched on again manually after having eliminated the cause.

In order to prevent the pump from running up unexpectedly after a mains power failure, the pump must be integrated into the control system in such a way that the pump can only be started by a manually operated switch. This applies equally to emergency cut-off switches.

In case of switching processes in connection with a pump which has warmed up under operating conditions, the pump must then not be directly switched on again.

Warning



4.3 Ultimate pump pressure

If the system cannot produce the pressures specified in the technical data, measure the ultimate pressure directly at the pump's intake port after disconnecting the pump from the system. The ultimate pressure of non-condensable gases (partial pressure of air) can only be measured with a compression vacuum gauge or a partial pressure gauge. Precise measurements can only be obtained with calibrated instruments.

Upon initial start-up, after prolonged idle periods or after an oil change, it takes a while until the pump reaches the specified ultimate pressure. The pump must attain its operating temperature, and the pump oil must be degassed. We recommend operating the pump initially with the gas ballast valve open.

The ultimate pressure depends on the pump temperature and the pump oil used. The best ultimate pressures can be obtained at a low pump temperature and by using the recommended oil types.

4.4 Taking out of use

Please contact Leybold for all relation question about the disposal of spares, consumables or the entire pump

5 Maintenance

5.1 Safety Information

Observe all safety regulations.

All work must be done by suitably trained personnel. Maintenance or repairs carried out incorrectly will affect the life and performance of the pump, may change its CE compliance or ATEX ratings and may cause problems when filing warranty claims or free Leybold from any responsibility. All work must be done by suitably trained ATEX personnel on ATEX pumps. Before any maintenance operations are carried out on the pump it should be ensured that the pump and its surroundings are free from flammable atmospheres and dust deposits.

Where dust can be deposited on the pump or motor surfaces, provision should be made to ensure that these are removed regularly. The pump must remain clean & dust-free. **The cleaning must be done with cloths / products avoiding static charges.**

The non-respect of the maintenance recommendations can lead to pump damage or to risks for the user or the environment.

Never mount used seals; always mount new seals. Only the use of genuine Leybold parts is allowed! Any integration of non Leybold parts or non-authorized repairs will cancel the pump CE or ATEX certification and will waive all Leybold responsibilities.

Disconnect the power before disassembling the pump. Make sure that the pump cannot be accidentally started.

If the pump has pumped harmful substances, ascertain the nature of the hazard and take adequate safety measures. Observe all safety regulations. The equipment must be maintained in such a way that the safety of the system is not impaired in any way.

The system instruction manual details the routine maintenance tasks that are necessary to maintain CE & ATEX compliance. Where the customer wishes to conduct more complex maintenance / overhaul tasks it is necessary for them to be trained by Leybold and supplied with the correct maintenance / inspection tooling.

In addition to the maintenance operations given in the manual, a complete overhaul of the pump including the replacement of the motor bearings should be carried out every 15'000 h of operation or every 3 years whichever is the sooner.

Warning



Maintenance

5.2 Maintenance Intervals

The intervals stated in the maintenance schedule are approximate values for normal pump operation. Unfavorable ambient conditions and/or aggressive media may significantly reduce the maintenance intervals.

Warning



Maintenance job non ATEX pumps	Frequency	Section
Checking the oil level	Daily.	5.4.A
Checking the oil condition	Depends of process, at least weekly.	5.4.B
First oil change	After 150 hours of operation.	5.4.C
Following oil changes	Depends of process. Clean processes and LVO700/710 oil allow up to 3 years	5.4.C
Changing the exhaust and oil filters	If oil mist at exhaust or at indication of exhaust filter pressure sensor. At least annually. Clean processes and LVO700/710 oil allow up to 3 years	5.4.D
Checking the float valve	At each exhaust filter change or at least yearly.	5.4.E
Cleaning the intake port dirt trap	Depends of process, at least monthly.	5.4.F
Checking the anti-suck back valve	Depends of process, at least yearly.	5.4.F
Replacing the Pump Module	In case of specific pump servicing.	5.4.H
Replacement of electrical motor	In case of specific pump servicing.	5.4.I

Maintenance job ATEX pumps	Frequency	Section
Checking the oil level	Daily.	5.4.A
Checking the oil condition	Depends of process, at least weekly. Thorough check every 6 months	5.4.B
First oil change	After 150 hours of operation.	5.4.C
Following oil changes	Depends of process. Clean processes and LVO700/710 oil yearly	5.4.C
Changing the exhaust and oil filters	If oil mist at exhaust or at indication of exhaust filter pressure sensor. At least annually. Filter condition and back-pressure to be checked every 6 months. Back pressure max. 0.5 bar rel. when pump inlet at atm pressure	5.4.D
Pump temperature check	To be checked every 6 months. Max. 30 °C increase vs new condition	
Checking the float valve	At each exhaust filter change or at least yearly.	5.4.E
Cleaning the intake port dirt trap	Depends of process, at least monthly.	5.4.F
Checking the anti-suck back and gas ballast valves	Depends of process, at least yearly.	5.4.F
Replacing the Pump Module	In case of specific pump servicing.	5.4.H
Replacement of electrical motor	In case of specific pump servicing.	5.4.I

To simplify the maintenance work, we recommend combining several jobs.

Maintenance

5.3 Service at Leybold facilities

If you send a pump to us, indicate whether the pump is free of substances damaging to health or whether it is contaminated. If it is contaminated also indicate the nature of hazard. For this you must use the form we have prepared, and which will be provided upon request.

A copy of this form, "Declaration of Contamination of Vacuum Instruments and Components" is reproduced at the end of the Operating Instructions.

Another suitable form is available from
<https://www.leybold.com/en/downloads/download-documents/declaration-of-contamination/>

Please attach this form to the pump or enclose it with it. This statement detailing the type of contamination is required to satisfy legal requirements and for the protection of our employees.

We will return any pump received without a "Declaration of Contamination" to the sender's address.

The pump must be packaged in such a way that it will not be damaged during shipping, and so that no harmful substances can escape from the package. If you open a pump at your own works also observe a potential contamination.

When disposing of used oil, please observe the relevant environmental regulations. Due to the design concept, SOGEVAC pumps require very little maintenance under normal operating conditions. The work required is described in the sections below.

All work must be done by suitably trained personnel. Maintenance or repairs carried out incorrectly will affect the life and performance of the pump and may cause problems when filing warranty claims.

In connection with this, you may be interested in the Leybold practical seminars, in which maintenance, repair and testing information for the Sogevac pumps is conveyed by qualified trainers.

Warning



Warning



5.4 Maintenance Work

5.4.A Checking the oil level

The pump's oil level during operation must always be in the upper quarter of the oil-level glass. When necessary, switch off the pump and add the correct quantity of oil.



Overfilling leads to oil losses at high intake pressures. High oil consumption often indicates that exhaust filters are clogged (See 5.4.D).

The oil level should be checked at least once a day. Stop the pump for filling oil.

5.4.B Checking the oil condition

Normally the oil is clear and transparent. If the oil darkens, it is an indication that the oil must be checked.

The oil must be changed if:

- Its viscosity increases by 20 % compared to new oil.
- Its Total Acid Index exceeds given limits, depending of oil type. Please consult us.

If gases or liquids dissolved in the oil result in deterioration of the ultimate pressure, the oil can be degassed by letting the pump running for about 30 min. with the intake port closed and the gas ballast valve open.

The amount of oil required for an oil check should be drained via the oil-drain plug into a beaker or similar container with the pump switched off but still at operating temperature.

Bad oil quality can cause a pump temperature increase, which can influence the pump ATEX temperature rating!

Depending on the process involved, dangerous substances may escape from the pump and oil. Take the appropriate precautions.

Observe the safety regulations.

Check to be carried out, depending of process, at least weekly.

Warning



5.4.C Oil change

Always change the oil when the pump is switched off but still at working temperature.

If there is a risk of the oil being polymerized by the connected process, change the oil immediately after operation of the pump.

Pump in function is hot and some surfaces could reach a temperature higher than 80 °C (176 °F).

There is a risk of burn by touching.



Open the oil-drain valve and let the used oil drain into a suitable container. Depending on the process involved, dangerous substances may escape from the pump and oil. Take the appropriate precautions.

Observe the safety regulations.

When disposing of used oil please observe the relevant environmental regulations!

When the flow of oil slows down close the oil-drain valve, briefly switch on the pump (max. 10s) and switch it off. Drain the remaining oil.

Unscrew the oil-fill plug and fill the pump. In case of severe pollution, it should be flushed by filling it with fresh oil up to the bottom edge of the oil-level glass, run it for a short time and then change the oil again.



Use suitable oil only (see Section 1.9).

Depending on the process involved, dangerous substances may escape from the pump and oil. Take the appropriate precautions.

Never mount used seals; always mount new seals.

When disposing of used oil please observe the relevant environmental regulations!

Warning



Warning



5.4.D Replacing the Exhaust Filters

Tools required:

- Allen key 6 mm.
- Box wrench 10 mm.
- oil filter key (710 73 532)

- Remove the 4 screws of the exhaust filter cover plate

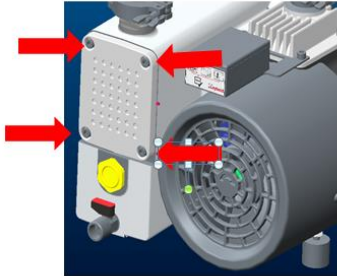

- Pull out the exhaust filter

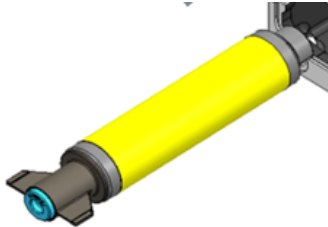

- Verify on the new exhaust filter that the O-Ring is present
- Mount the new exhaust filter.
- Tighten the 4 screws of the exhaust filter cover plate with 9.5 Nm.

Respect the indications on the oil filter for changing the latter.

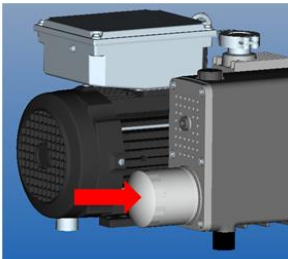

Depending on the process involved, dangerous substances may escape from the pump and oil. Take the appropriate precautions.

Observe the safety regulations.

Important

When disposing of used filters please observe the relevant environmental regulations!

Never mount used seals; always mount new seals.

Warning



Maintenance

5.4.E Checking the float valve

Tools required: Allen Key 6 mm

If the pressure does not fall below approx. 5 mbar during pump operation, check the tightness of the float valve.

Remove the exhaust filter with the exhaust flange.

Remove the float valve screw and pull the float valve assembly out of the float chamber.

Take off the gasket.

Clean the nozzle. Check the tightness of the float valve.

Check all gaskets and replace them with new ones if necessary.

Reassemble the float valve in the reverse sequence.

Depending on the process involved, dangerous substances may escape from the pump and oil. Take the appropriate precautions.

Never mount used seals; always mount new seals.

Warning



Caution

5.4.F Cleaning the intake port dirt trap and Checking the anti-suck back and gas ballast valves

Cleaning the intake port dirt trap and gas ballast air filter

Tools required: open-jaw or box wrench 13 mm. Allen key 6 mm

A dirt trap for coarse particles is located in the intake flange of the pump. It shall be kept clean to avoid reduction of the pumping speed.

The dirt trap consists of a wire-mesh screen.

Disassemble the intake hose or pipe.

Take out the wire-mesh screen and clean them using a suitable solvent.

Reassemble in the reverse sequence.

Check the condition of the anti-suck back and gas ballast valves and clean or replace if needed. Clean or replace the gas ballast air filter (on 3 position manual gas ballast).

Depending on the process involved, dangerous substances may escape from the pump and oil. Take the appropriate precautions.

Never mount used seals; always mount new seals.

Warning



Maintenance

Checking the Anti-Suck back Valve

Tools required:
- Allen key 6 mm

Keep the anti-suck back valve clean to ensure proper operation of the pump. In any application we strongly recommend installing a polyester dust filter upstream.

First disconnect the intake line.

Remove four screws and take off the intake flange and gasket.

Remove the anti-suck back valve and clean it.

Reassemble the intake port. We recommend replacing the gasket with a new one.

Depending on the process involved, dangerous substances may escape from the pump and oil. Take the appropriate precautions.

Observe the safety regulations.

Never mount used seals; always mount new seals.

Depends of process, but to be done at least yearly.

Warning



Caution

5.4.H Replacing the Pump Module

Please consult Leybold

5.4.I Replacement of electrical motor

Please consult Leybold for specific maintenance works to be carried e.g. bearing replacement.

The motor can only be exchange with an identical one for the same manufacturer and marking.

In case other motors are used, the pump loses its CE & ATEX certification.



Warning

Trouble shooting

6 Trouble shooting

Fault	Possible cause	Remedy
Pump does not start.	Pump is connected incorrectly. Motor protection switch incorrectly set. Operating voltage does not match motor. Motor is malfunctioning. Oil temperature is below 12°C (54°F). Oil is too viscous. Exhaust filter / exhaust line is clogged. Power transmission by V-belts is impaired. Pump is seized up	Connect the pump correctly. Set motor protection switch properly. Replace the motor. Replace the motor. Heat the pump and pump oil or use different oil. Use appropriate oil grade. Replace the filter or clean the exhaust line. Tighten or replace the V-belts. Repair the pump.
Pump does not reach ultimate pressure.	Measuring technique or gauge is unsuitable. External leak Float valve does not close. Anti-suckback valve is malfunctioning. Inadequate lubrication due to: ■ unsuitable or contaminated oil, ■ clogged oil filter, ■ clogged oil lines. Vacuum lines are dirty. Pump is too small.	Use correct measuring technique and gauge. Repair the pump. Repair the valve. Repair the valve. Change the oil (degas it, if necessary). Replace the oil filter. Clean the oil casing. Clean vacuum lines. Check the process date; replace the pump, if necessary.
Pumping speed is too low.	Dirt trap in the intake port is clogged. Exhaust filter is clogged. Connecting lines are too narrow or too long. Anti-suckback valve is hard to open.	Clean the dirt trap ; Precaution : install a dust filter in intake line. Install new filter elements. Use adequately wide and short connecting lines. Check spring free length.
After switching off pump under vacuum, pressure in system rises too fast.	System has a leak. Anti-suckback is malfunctioning.	Check the system. Repair the valve.
Pump gets too hot	Cooling air supply is obstructed. Cooler is dirty. Ambient temperature is too high. Process gas is too hot. Oil level is too low. Oil is unsuitable. Oil cycle is obstructed. Exhaust filter / exhaust line is obstructed. Pump module is no longer usable.	Set pump up correctly. Clean the cooler. Set pump up correctly. Change the process. Add oil to reach the correct oil level. Change the oil. Clean or repair the oil lines. Replace the exhaust filter, clean the exhaust line. Replace the pump module.

Trouble shooting

Fault	Possible cause	Remedy
Oil in intake line or in vacuum vessel.	Oil comes from the vacuum system. Anti-suckback valve is obstructed. Sealing surfaces of anti-suckback valve are damaged or dirty. Oil level is too high.	Check the vacuum system. Clean or repair the valve. Clean or repair the intake port and valve. Drain the excess oil.
Pump's oil consumption too high, oil mist at exhaust.	Exhaust filters are clogged or damaged. Nozzle of float valve is clogged. Oil level is too high.	Replace the filters. Check the valve, clean the nozzle. Drain the excess oil.
Oil is turbid.	Condensation.	Degas the oil or change the oil and clean the pump. Precaution : open the gas ballast valve or insert a condensate trap. Clean the gas ballast intake filter.
Pump is excessively noisy.	Oil level is very low (oil is no longer visible). Oil filter is clogged. Large vacuum leak in system.	Add oil. Change the oil and filter. Repair vacuum leak.

* Reference section: This column refers to the section in the Operating Instructions that contains the applicable repair information.

Spare parts

7 Spare parts

To guarantee safe operation of the Leybold pump, only original & genuine spare parts and accessories shall be used. When ordering spare parts and accessories, always state pump type and serial number. You can find part numbers in the spare parts list.

The pump loses its CE & ATEX certification if non-genuine Leybold parts are used.

Consumables and main spare parts kits for SOGEVAC pumps are usually available on stock at Leybold service centers. The list of these parts is given here after and in the spare parts table where the contents of each kits is detailed.

- Exhaust demisters
- Oils (Special oils please refer to the specific notice of the pump or contact Leybold).
- Maintenance kit
- Repair kit

We recommend using these kits which have been defined to allow an optimal maintenance or repair. Individual spare parts may need longer delivery time.

Warning



Spare parts

Are in a separate document

Spare parts



EU Declaration of Conformity

(Translation of original Declaration of Conformity)

The manufacturer: Leybold France SAS
640 rue Aristide Bergès
26500 Bourg Les Valence
France

herewith declares, under the sole responsibility of the manufacturer, that the products specified and listed below which we have placed on the market, comply with the applicable EU Council Directives. This declaration becomes invalid if modifications are made to the product without agreement of Leybold.

Product designation: SOGEVAC NEO D
Type designation: SV NEO D 16, SV NEO D 25, SV NEO D 40, SV NEO D 65
and their variants

The products comply to the following European Council Directives:

Machinery Directive (2006/42/EC)

The safety objectives of the Low Voltage Directive 2014/35/EU were complied with in accordance with Appendix 1 No. 1.5.1 of Machinery Directive 2006/42/EC.

Electromagnetic Compatibility (2014/30/EU)

RoHS Directive (2011/65/EU) & (2015/863/EU)

The following harmonized standards have been applied:

EN 1012-2:1996+A1:2009	Compressors and vacuum pumps — Safety requirements — Part 2: Vacuum pumps
EN 60204-1:2006/A1:2009	Safety of machinery — Electrical equipment of machines — Part 1: General requirements
EN 61000-6-2:2005	Electromagnetic compatibility (EMC) - Part 6-2: Generic standards - Immunity for industrial environments
EN 61000-6-4:2007/A1:2011	Electromagnetic compatibility (EMC) - Part 6-4: Generic standards - Emission standard for industrial environments

Documentation officer: Leybold France SAS, 640 rue Aristide Bergès,
26500 Bourg Les Valence, France

Cologne, April 17, 2020

Andries DE BOCK
VP Engineering
Industrial Vacuum Division

Bourg Les Valence, April 17, 2020

Joseph SCHOTT
General Manager Leybold Valence

China RoHS Declaration

Materials Declaration

材料声明

In accordance with the requirements of the Chinese regulatory requirement on the Management Methods for the Restriction of the Use of Hazardous Substances in Electrical and Electronic Products Order No. 32 (also known as 'China RoHS 2.0') and SJ/T 11364 Marking for the Restricted Use of Hazardous Substances in Electronic and Electrical Products:

依照中国对电子电器产品有害物质限制使用管理办法的法律法规要求 - 第32条的规定 (即中国RoHS 2.0), 和对电子电器产品有害物质限制使用需要进行标识管理的规定 SJ/T 11364.

Product Labels 产品标签

Product 产品	Product Label 产品标签	Meaning 标签含义
All pumps in the list below 列入下表中的所有泵		This product contains hazardous substances in at least one of the homogeneous materials used which are above the limit requirement in GB/T 26572 as detailed in the declaration table below. These parts can safely be used for the environmental protection use period as indicated. 本产品含有至少一种均质材料, 超出了GB/T 26572规定的限制要求, 详见下文的申报表。这些产品可以在标签上所写的环境保护使用期限内安全的使用。

Pump Type 泵的类型	Pump Size 泵的规格
Sogevac pump 单级旋片泵	SV10B, SV16B, SV16D(I), SV25D(I), SV25B, SV28BI, SV40B(I FC), SV40ATEX Cat 1, SV65B(I FC), SV100B, SV120B(I FC), SV160B, SV200, SV220B, SV300B, SV320B, SV470B(F), SV570B(F), SV630B(F), SV750B(F), SV1200 SV Neo D 16, SV Neo D 25, SV Neo D 40, SV Neo D 65

Materials Content Declaration

材料成分声明

Part name 部件名称	Hazardous Substances 危险物质					
	Lead (Pb) 铅	Mercury (Hg) 汞	Cadmium (Cd) 镉	Hexavalent Chromium (Cr VI) 六价铬	Polybrominated biphenyls (PBB) 多溴联苯	Polybrominated diphenyl ethers (PBDE) 多溴二苯醚
Aluminium alloys 铸铝及铝合金制品	X	O	O	O	O	O
Steel alloys 钢合金制品	X	O	O	O	O	O
Brass pipe fitting 铜管管件	X	O	O	O	O	O
Brass connectors 铜接头	X	O	O	O	O	O
Electronic and Controls	X	O	X	O	O	O

O: Indicates that the hazardous substance contained in all of the homogeneous materials for this part is below the limit requirement in GB/T 26572.
O: 表示该有害物质在该部件的所有均质材料中的含量低于 GB/T 26572 标准规定的限量要求。

X: Indicates that the hazardous substance contained in at least one of the homogeneous materials used for this part is above the limit requirement of GB/T26572.
X: 表示该有害物质在该部件的至少一种均质材料中的含量超出 GB/T26572 标准规定的限量要求。

NOTES: The following Exemptions from EU RoHS apply:

说明: 以下情况可以免除欧洲RoHS的要求:

6(a) Lead as an alloying element in steel for machining purposes and in galvanised steel containing up to 0,35 % lead by weight.

铅作为合金元素在加工用途的钢和镀锌钢中的重量含量不高于0.35%。

6(b) Lead as an alloying element in aluminium containing up to 0.4% by weight.

铅作为合金元素在铝合金中的重量含量不高于0.4%。

6(c) Copper alloy containing up to 4% lead by weight.

铜合金中铅的重量含量不高于4%。

Declaration of Contamination



Declaration of Contamination of Compressors, Vacuum Pumps and Components

The repair and / or servicing of compressors, vacuum pumps and components will be carried out only if a correctly completed declaration has been submitted. Non-completion will result in delay. The manufacturer can refuse to accept any equipment without a declaration.

A separate declaration has to be completed for each single component.

This declaration may be completed and signed only by authorized and qualified staff.

Customer/Dep./Institute: _____ Address: _____ _____ Person to contact: _____ Phone: _____ Fax: _____ End user: _____	Reason for return: <input checked="" type="checkbox"/> applicable please mark Repair: <input type="checkbox"/> chargeable <input type="checkbox"/> warranty Exchange: <input type="checkbox"/> chargeable <input type="checkbox"/> warranty <input type="checkbox"/> Exchange already arranged / received Return only: <input type="checkbox"/> rent <input type="checkbox"/> loan <input type="checkbox"/> for credit Calibration: <input type="checkbox"/> DKD <input type="checkbox"/> Factory-calibr. <input type="checkbox"/> Quality test certificate DIN 55350-18-4.2.1															
A. Description of the Leybold product:																
Material description: _____ Catalog number: _____ Serial number: _____ Type of oil (ForeVacuum-Pumps): _____	Failure description: _____ Additional parts: _____ Application-Tool: _____ Application-Process: _____															
B. Condition of the equipment																
1. Has the equipment been used <input type="checkbox"/> No ¹⁾ <input type="checkbox"/> Yes <input type="checkbox"/> No 2. Drained (Product/service fluid) <input type="checkbox"/> No ¹⁾ <input type="checkbox"/> Yes <input type="checkbox"/> No 3. All openings sealed airtight <input type="checkbox"/> No ¹⁾ <input type="checkbox"/> Yes <input type="checkbox"/> No 4. Purged <input type="checkbox"/> No ¹⁾ <input type="checkbox"/> Yes <input type="checkbox"/> No If yes, which cleaning agent _____ and which method of cleaning _____ ¹⁾ If answered with "No", go to D.	Contamination: <input type="checkbox"/> No ¹⁾ <input type="checkbox"/> Yes toxic <input type="checkbox"/> No ¹⁾ <input type="checkbox"/> Yes corrosive <input type="checkbox"/> No ¹⁾ <input type="checkbox"/> Yes flammable <input type="checkbox"/> No ¹⁾ <input type="checkbox"/> Yes explosive ²⁾ <input type="checkbox"/> No ¹⁾ <input type="checkbox"/> Yes radioactive ²⁾ <input type="checkbox"/> No ¹⁾ <input type="checkbox"/> Yes microbiological ²⁾ <input type="checkbox"/> No ¹⁾ <input type="checkbox"/> Yes other harmful substances <input type="checkbox"/> No ¹⁾ <input type="checkbox"/> Yes															
C. Description of processed substances (Please fill in absolutely)																
1. What substances have come into contact with the equipment? Trade name and / or chemical term of service fluids and substances processed, properties of the substances According to safety data sheet (e.g. toxic, inflammable, corrosive, radioactive)																
<table border="1" style="width: 100%; border-collapse: collapse;"> <thead> <tr> <th style="width: 5%;">X</th> <th style="width: 35%;">Tradename:</th> <th style="width: 60%;">Chemical name:</th> </tr> </thead> <tbody> <tr> <td>a)</td> <td>_____</td> <td>_____</td> </tr> <tr> <td>b)</td> <td>_____</td> <td>_____</td> </tr> <tr> <td>c)</td> <td>_____</td> <td>_____</td> </tr> <tr> <td>d)</td> <td>_____</td> <td>_____</td> </tr> </tbody> </table>		X	Tradename:	Chemical name:	a)	_____	_____	b)	_____	_____	c)	_____	_____	d)	_____	_____
X	Tradename:	Chemical name:														
a)	_____	_____														
b)	_____	_____														
c)	_____	_____														
d)	_____	_____														
2. Are these substances harmful? <input type="checkbox"/> No <input type="checkbox"/> Yes 3. Dangerous decomposition products when heated? <input type="checkbox"/> No <input type="checkbox"/> Yes If yes, which? _____																
²⁾ Components contaminated by microbiological, explosive or radioactive products/substances will not be accepted without written evidence of decontamination.																

D. Legally binding declaration

I / we hereby declare that the information supplied on this form is accurate and sufficient to judge any contamination level.

Name of authorized person (block letters):	_____	firm stamp
Date	_____	
	signature of authorized person	

17200001_002_C2 © Leybold

Notes

Sales and Service

Germany

Leybold GmbH
Sales, Service, Support Center (3SC)
Bonner Strasse 498
D-50968 Cologne
T: +49-(0)221-347 1234
F: +49-(0)221-347 31234
sales@leybold.com
www.leybold.com

Leybold GmbH
Sales Area North
Branch Office Berlin
Industriestrasse 10b
D-12099 Berlin
T: +49-(0)30-435 809 0
F: +49-(0)30-435 809 10
sales.bn@leybold.com

Leybold GmbH
Sales Office South
Branch Office Munich
Karl-Hammerschmidt-Strasse 34
D-85609 Aschheim-Dornach
T: +49-(0)89-357 33 9-10
F: +49-(0)89-357 33 9-33
sales.mn@leybold.com
service.mn@leybold.com

Leybold Dresden GmbH
Service Competence Center
Zur Wetterwarte 50, Haus 304
D-01109 Dresden
Service:
T: +49-(0)351-88 55 00
F: +49-(0)351-88 55 041
info.dr@leybold.com

Europe

Belgium

Leybold Nederland B.V.
Belgisch bijkantoor
Leuvensesteenweg 542-9A
B-1930 Zaventem
Sales:
T: +32-2-711 00 83
F: +32-2-720 83 38
sales.zv@leybold.com
Service:
T: +32-2-711 00 82
F: +32-2-720 83 38
service.zv@leybold.com

France

Leybold France S.A.S.
Parc du Technopolis, Bâtiment Beta
3, Avenue du Canada
F-91940 Les Ulis cedex
Sales and Service:
T: +33-1-69 82 48 00
F: +33-1-69 07 57 38
info.ctb@leybold.com
sales.ctb@leybold.com

Leybold France S.A.S.
Valence Factory
640, Rue A. Bergès
B.P. 107
F-26501 Bourg-lès-Valence Cedex
T: +33-4-75 82 33 00
F: +33-4-75 82 92 69
marketing.vc@leybold.com

Great Britain

Leybold UK LTD.
Unit 9
Silverglade Business Park
Leatherhead Road
Chesington
Surrey (London)
KT9 2QL
Sales:
T: +44-13-7273 7300
F: +44-13-7273 7301
sales.ln@leybold.com
Service:
T: +44-13-7273 7320
F: +44-13-7273 7303
service.ln@leybold.com

Italy

Leybold Italia S.r.l.
Via Filippo Brunelleschi 2
I-20093 Cologno Monzese
Sales:
T: +39-02-27 22 31
F: +39-02-27 20 96 41
sales.mi@leybold.com
Service:
T: +39-02-27 22 31
F: +39-02-27 22 32 17
service.mi@leybold.com

Netherlands

Leybold Nederland B.V.
Floridadreef 102
NL-3565 AM Utrecht
Sales and Service:
T: +31-(30) 242 63 30
F: +31-(30) 242 63 31
sales.ut@leybold.com
service.ut@leybold.com

Switzerland

Leybold Schweiz AG
Hinterbergstrasse 56
CH-6312 Steinhausen
Warehouse and shipping address:
Riedthofstrasse 214
CH-8105 Regensdorf
Sales:
T: +41-44-308 40 50
F: +41-44-302 43 73
sales.zh@leybold.com
Service:
T: +41-44-308 40 62
F: +41-44-308 40 60
service.zh@leybold.com

Spain

Leybold Hispánica, S.A.
C/. Huelva, 7
E-08940 Cornellá de Llobregat
(Barcelona)
Sales:
T: +34-93-666 43 11
F: +34-93-666 43 70
sales.ba@leybold.com
Service:
T: +34-93-666 46 11
F: +34-93-685 43 70
service.ba@leybold.com

America

USA

Leybold USA Inc.
5700 Mellon Road
USA-Export, PA 15632
T: +1-724-327-6700
F: +1-724-325-3577
info.ex@leybold.com
Sales:
T: +1-724-327-6700
F: +1-724-333-1217
Service:
T: +1-724-327-6700
F: +1-724-325-3577

Brazil

Leybold do Brasil
Rod. Vice-Prefeito Hermenegildo Tonolli,
nº. 4413 - 6B
Distrito Industrial
Jundiá - SP
CEP 13.213-086
Sales and Service:
T: +55 11 3395 3180
F: +55 11 99467 5934
sales.ju@leybold.com
service.ju@leybold.com

Asia

P. R. China

Leybold (Tianjin)
International Trade Co. Ltd.
Beichen Economic
Development Area (BEDA),
No. 8 Western Shuangshen Road
Tianjin 300400
China
Sales and Service:
T: +86-400 038 8989
F: +86-800 818 0033
T: +86-22-2697 4061
F: +86-22-2697 2017
sales.tj@leybold.com
service.tj@leybold.com

India

Leybold India Pvt Ltd.
T-97/2, MIDC Bhosari
Pune-411 026
India
Sales and Service:
T: +91-80-2783 9925
F: +91-80-2783 9926
sales.bg@leybold.com
service.bg@leybold.com

Japan

Leybold Japan Co., Ltd.
Headquarters
Shin-Yokohama A.K.Bldg., 4th floor
3-23-3, Shin-Yokohama
Kohoku-ku, Yokohama-shi
Kanagawa-ken 222-0033
Japan
Sales:
T: +81-45-471-3330
F: +81-45-471-3323
sales.yh@leybold.com

Leybold Japan Co., Ltd.
Tasukuba Technical Service Center
1959, Kami-yokoba
Tasukuba-shi, Ibaraki-shi 305-0854
Japan
Service:
T: +81-29 839 5480
F: +81-29 839 5485
service.ik@leybold.com

Malaysia

Leybold Malaysia
Leybold Singapore Pte Ltd.
No. 1 Jalan Hi-Tech Park
Kulim, Kedah Darul
Aman 09000
Malaysia
Sales and Service:
T: +604 4020 222
F: +604 4020 221
sales.ku@leybold.com
service.ku@leybold.com

South Korea

Leybold Korea Ltd.
3F, Jellzone 2 Tower
Jeongja-dong 159-4
Bundang-gu Sungnam-si
Gyeonggi-do
Bundang 463-384, Korea
Sales:
T: +82-31 785 1367
F: +82-31 785 1359
sales.bd@leybold.com
Service:
623-7, Upsong-Dong
Cheonan-Si
Chungcheongnam-Do
Korea 330-290
T: +82-41 589 3035
F: +82-41 589 0166
service.on@leybold.com

Singapore

Leybold Singapore Pte Ltd.
42 Loyang Drive
Loyang Industrial Estate
Singapore 508962
Singapore
Sales and Service:
T: +65-6303 7030
F: +65-6773 0039
sales.sg@leybold.com
service.sg@leybold.com

Taiwan

Leybold Taiwan Ltd.
10F., No. 32, Chenggong 12th St.,
Zhubei City, Hsinchu County 302
Taiwan, R.O.C.
Sales and Service:
T: +886-3-500 1688
F: +886-3-583 3999
sales.hc@leybold.com
service.hc@leybold.com