



Axis Trichome Separator

Axis User Manual
R1.1

Table of Contents

1

1. [Introduction](#)

- 1.1. [Warranty](#)
- 1.2. [What's Included](#)
- 1.3. [Technical Specifications](#)
- 1.4. [Definitions](#)
- 1.5. [Disclaimers & Safety Precautions](#)
- 1.6. [Uncrating Your Axis](#)

2. [System Overview](#)

- 2.1. [Defining the System](#)
 - 2.1.1. [Interlocks, E-Stop & Motor Enable](#)
 - 2.1.2. [Light Tower Function](#)
 - 2.1.3. [Control Stand](#)
- 2.2. [System Dimensions](#)
- 2.3. [Basic Movement & Operation](#)
- 2.4. [Paddles](#)

3. [Vessel Setup](#)

- 3.1. [Center Drain Setup](#)
 - 3.1.1. [Alternative Setup](#)
- 3.2. [Dolly Setup](#)
 - 3.2.1. [65 Gallon Dolly Setup](#)
 - 3.2.2. [65 Gallon Dolly Setup continued](#)
 - 3.2.3. [65 Gallon Dolly Setup Schematic](#)
 - 3.2.4. [65 Gallon Dolly Setup, Center Drain](#)
 - 3.2.5. [30/44 Gallon Dolly Setup](#)
 - 3.2.6. [30/44 Gallon Dolly Setup continued](#)
 - 3.2.7. [44 Gallon Dolly Schematic](#)
 - 3.2.8. [30 Gallon Dolly Schematic](#)
- 3.3. [Insulation Adjustment](#)

4. [Axis Setup](#)

- 4.1. [Cable Management](#)
 - 4.1.1. [Cable Management continued](#)
- 4.2. [Compressed Air Supply](#)
- 4.3. [Guard Installation](#)
- 4.4. [Leveling the Axis](#)
 - 4.4.1. [Leveling the Axis continued](#)
 - 4.4.2. [Leveling the Axis continued](#)
- 4.5. [Wash Liner Installation](#)
 - 4.5.1. [Washer Liner Installation continued](#)

5. [Axis Touchscreen Interface](#)

- 5.1. [Home Screen](#)
- 5.2. [Joystick Patterns](#)
 - 5.2.1. [Joystick Patterns continued](#)
- 5.3. [Table Patterns](#)
 - 5.3.1. [Table Patterns continued](#)
- 5.4. [Quick Wash](#)
- 5.5. [Recipes](#)
 - 5.5.1. [Recipes continued](#)
 - 5.5.2. [Recipes continued](#)
- 5.6. [History](#)
- 5.7. [System Settings](#)
 - 5.7.1. [System Settings continued](#)
- 5.8. [Warnings & Error Messages](#)

Table of Contents

2

6. Material Processing

- 6.1. [Material Quality](#)
- 6.2. [Intended Use](#)
- 6.3. [Single Vessel](#)
- 6.4. [Multiple Vessels](#)
- 6.5. [Filtration](#)

7. Cleaning the Axis

- 7.1. [Power Down](#)
- 7.2. [Vessel Guard Removal & Cleaning](#)
- 7.3. [Cleaning the Axis](#)
- 7.4. [Control Stand Cleaning](#)
- 7.5. [Paddle & Coupler Cleaning](#)
- 7.6. [Vessel Cleaning](#)

8. [Maintenance & Troubleshooting](#)

- 8.1. [Common Issues](#)
 - 8.1.1. [Common Issues continued](#)
 - 8.1.2. [Common Issues continued](#)
- 8.2. [Frequently Asked Questions](#)

1. Introduction

3



From all of us here at PurePressure, thank you for your purchase!

The Axis trichome separator is engineered to last for many years with proper care. The following user manual covers virtually every topic, including how to use the machine, technical specifications, tips on getting the most out of your Axis, and much more.

Sales Inquiries:

sales@gopurepressure.com

General Questions:

info@gopurepressure.com

Technical Support:

support@gopurepressure.com

Contact:

 720-446-9565

 purepressure.com

   @gopurepressure

— **We're always here to help. Talk to us!**

1.1 Warranty

4

PurePressure's trichome separators are built to last for many years with proper care. We want you to be satisfied with your equipment so if there are ever any concerns, please do not hesitate to contact us. PurePressure guarantees the following warranty coverage for the Axis Trichome Separator:

- 2 year limited warranty against manufacturing defects for structural components (frame, sheet metal, and custom machined parts).
- 1 year limited warranty against manufacturing defects for the entire trichome separator including electronic and pneumatic components.

Warranty Replacements: In event of an approved warranty replacement or service, PurePressure will supply the necessary part(s) and special tools, if needed. Shipping costs may be covered by PurePressure at its discretion.

Replacement Parts: Replacement parts for various components are available at reasonable prices for press owners directly from PurePressure.

Exclusions: Warranty coverage eligibility will be determined by PurePressure and at PurePressure's sole discretion. PurePressure's warranty obligations do not include (i) reasonable wear and tear; (ii) damage or corrosion caused by an electrical enclosure not being properly closed/sealed; (iii) use of unapproved parts or unproved alterations to components; (iv) defects or damage caused by misuse, improper electrical power supply, or compressed air inputs over 120 PSI (v) pneumatic components damaged from internal moisture or having been pressurized with compressed air which is not clean or dry; (vi) vandalism, negligence, misuse or Force Majeure Events; or (vi) items expected to be consumed or expended during the normal and routine operation and maintenance. This warranty is eligible for the original purchaser only and is not transferable.

Disclaimer: Except as expressly set forth in this Limited Warranty and to the greatest extent allowed by law, PurePressure makes no other representations, warranties or conditions, express or implied, including any implied representations, warranties or conditions of merchantability, fitness for a particular purpose, non-infringement, and non-interference.

Warranty Procedures: If your automated washing machine is covered under the warranty period, please contact us with detailed information regarding the issue you are experiencing so that we can get you operational as soon as possible. If you are experiencing a problem and are outside of the warranty period, we will do everything in our power to get you affordable replacement component(s) in a timely manner. Please send all warranty and replacement part related inquiries to support@gopurepressure.com. All returned parts must be accompanied by an RMA number, which we will supply.

1.2 What's Included

5

What's Included With Your Axis:

(items may differ depending on kit or model)

- (x1) Axis trichome separator
- (x1) Control stand with touchscreen (connected to Axis)
- (x1) Vessel guard
 - (3x) 1/4-20x1in Button Head Screws
- (x1) Paddle for 65 gallon vessels*

*Additional sizes available for purchase



1.3 Technical Specifications

Specifications & Requirements	Axis, 120V / 240V
Weight	Axis - 260 lbs, Control Stand - 90 lbs -> Total = 350 lbs
Overall Dimensions Depth x Width x Height	53.1" x 72.4" x 84.0"
Paddle System	Quick change paddle system for all 3 vessel sizes (30, 44, 65)
Vessel Options*	3 vessel sizes (65gal, 44gal, 30gal) *Elevated dolly required
Frame & Enclosure Metal	Stainless Steel housing 6061-Aluminum frame Stainless Steel hardware
Servo Motor Drive	2-80 RPM Food grade belt drive, tension to 28-29 Hz Food grade sealed bearings
Electrical	IP65 rated electrical components UL508A rated control panel
Vessel Guard	Removable, PETG
Power	100-120VAC, 7A, 50-60Hz 220-240VAC, 4A, 50-60Hz
Compressed Air	120 psi, dry clean air

1.4 Definitions

7

The Control Stand houses the touchscreen interface and consists of a podium-style frame, main electrical control panel, and joystick. All electrical functions of the Axis Trichome Separator are controlled here.

Axis Trichome Separator is the main agitation unit that includes the vertical support framing and the relocating head.

Relocating Head is the mobile component of the Axis Trichome Separator. It has the ability to raise, lower, and pivot 90 degrees. This allows the operator to traverse from one vessel to another.

Vessel Guard is the safety cover and splash guard which protects the operator from paddle movement. The universal vessel guard is designed to fit 3 Bruteless vessel sizes (30, 44, & 65 gallon). It is a thermal-formed part made from food grade PETG, and is transparent in color, which allows the operator to see the process at work.

Interlock is an arrangement of safety switches which needs to be satisfied in order for the paddle to operate. If any of these switches are not fulfilled, the motor will not function, preventing an unsafe scenario and injury.

Servo Motor is a closed-loop motor system that uses positional feedback to create accurate and repeatable movements.

Servo Drive is a component in the main electrical box that communicates directly with the Servo Motor. The main PurePressure control board communicates paddle movements to the Servo Drive, which then communicates with the Servo Motor to execute those movements.

Pneumatic Cylinders are mechanical devices which use the power of compressed gas to produce a force in a reciprocating linear motion.

Gas Spring is a type of spring that relies of compressed gas to provide a linear force. The Gas Spring supports the weight of the relocating head while the Pneumatic Cylinder drives vertical movement up and down.

Cable Conduit is a corrugated, split plastic sheath for the protection of electrical cables and pneumatic tubing.

Cable Track (E-Track) is a plastic chain-style cable carrier that both protects the cables and limits the bending radius while cables are in motion. The Axis has a vertical and horizontal Cable Track.

Paddle Coupler is a mechanical component on the Axis paddle that connects to the drive shaft of the Axis relocating head.

Drive Belt is a toothed belt that attaches to belt-driven pulleys allowing a mechanical transfer of force from the motor to the paddle shaft.

Lifting Eye is an eyelet bolt that comes mechanically fastened to the Axis for lifting the machine.

Wash Vessel is a Bruteless insulated stainless steel vessel used for the cold water mechanical extraction of cannabis trichomes.

Filter Vessel is a Bruteless insulated stainless steel vessel dedicated for use during the filtration process of cannabis trichomes.

1.5 Disclaimers & Safety Precautions

8



Please review this information carefully prior to Axis operation!

DISCLAIMER: WHILE UNPLUGGED, INSPECT INSIDE ELECTRICAL CONTROL BOX AFTER CLEANING FOR ANY WATER MIGRATION.

DISCLAIMER: COMPRESSED AIR SOURCE REQUIRED. MAX ALLOWABLE WORKING PRESSURE 120 PSI. THIS PRODUCT RAISES AND LOWERS UTILIZING A PNEUMATIC CYLINDER.

DISCLAIMER: CONNECTING TO ANY OTHER POWER SOURCE OTHER THAN WHAT YOUR TRICHOME SEPARATOR IS RATED FOR ON ITS SERIAL LABEL WILL VOID YOUR WARRANTY.

DISCLAIMER: ALWAYS USE BOTH FASTENING METHODS WHEN INSTALLING PADDLES (HYGIENIC CLAMPING LEVER AND QUICK RELEASE PIN ON PADDLE COUPLER).

DISCLAIMER: ONLY OPERATE THE EQUIPMENT WITH MANUFACTURER'S RECOMMENDED CABLE MANAGEMENT SYSTEM IN PLACE.

WARNING: ONLY USE THE DESIGNATED AC POWER PLUG PROVIDED WITH YOUR TRICHOME SEPARATOR. ENSURE POWER SUPPLY MEETS ELECTRICAL REQUIREMENTS.

WARNING: EMERGENCY STOP BUTTON - YOU MAY CANCEL THE OPERATION AT ANY POINT BY PRESSING THE EMERGENCY STOP BUTTON. THIS WILL DISPLAY EMERGENCY STOP ON THE LED TOUCH SCREEN AND WILL CUT POWER TO THE MOTOR.

WARNING: DO NOT WASH ANYTHING OTHER THAN SOFT PLANT MATERIALS IN THE TRICHOME SEPARATOR. WASHING OTHER OBJECTS WILL VOID THE WARRANTY.

WARNING: WHEN USING ISOPROPYL ALCOHOL TO CLEAN THE AXIS THE POWER SHOULD BE DISCONNECTED. ALWAYS WEAR GLOVES AND EYE PROTECTION.

WARNING: THERE IS A RISK OF ELECTRICAL SHOCK. PROPER RECEPTACLE GROUNDING IS REQUIRED.

WARNING: PINCH POINT CAN CAUSE SERIOUS INJURY. NEVER PLACE FOREIGN OBJECTS, FINGERS, HANDS OR OTHER BODY PARTS NEAR HINGES AND OTHER LABELED PINCH POINTS.

WARNING: ALWAYS WEAR EYE AND EAR PROTECTION AS WELL AS HEAT RESISTANT GLOVES FOR SAFE OPERATION.

WARNING: PUREPRESSURE, LLC IS NOT RESPONSIBLE FOR INJURY OR LOSS DUE TO IMPROPER USE OF EQUIPMENT.

WARNING: DO NOT OPERATE MACHINE WITHOUT ENCLOSURE COVERS AND BELT GUARD IN PLACE.

WARNING: DO NOT OPERATE THE RELOCATING HEAD WITH ANYONE IN THE PATH OF MOVEMENT. SERIOUS INJURY MAY OCCUR.

WARNING: TRIPPING HAZARD PRESENT. THE FLOOR SUPPORTING FRAME EXTENDS BEYOND THE MACHINE, BE AWARE OF YOUR SURROUNDINGS. SERIOUS INJURY MAY OCCUR.

WARNING: BE AWARE OF YOUR SURROUNDINGS, DO NOT WALK UNDER THE RELOCATING HEAD. SERIOUS INJURY MAY OCCUR.

WARNING: ALWAYS CHECK THE POSITION OF YOUR PNEUMATIC TOGGLE BEFORE APPLYING COMPRESSED AIR TO YOUR SYSTEM.

1.6 Uncrating Your Axis

Note: Use team lifting or a power lift to move the unit safely!

Steps to Safely Uncrate Your Axis

- Tools required for unpacking:
 - a. Lifting provisions for pallet moving & placing the Axis
 - Pallet jack
 - Fork lift
 - Engine hoist (for removing unit from pallet)
 - b. Lifting Strap
 - c. Phillips screwdriver, a driver bit with an impact, or drill works best
 - d. 9/16" hex socket or flat wrench

- 1. Inspect all packaging for damage before accepting the shipment. Be sure that the forklift or something else has not penetrated the packaging and damaged the product.
- 2. Cut off any external shrink wrap.
- 3. Remove any 2x4's supporting the Axis head of the machine first.
- 4. Take note of any screws that need to be removed to disassemble the sides of the crate. Start with a large side, then the two smaller sides. and finally the last large side.
- 5. Remove the boxes within the pallet. These should contain the guard, paddle, cable support post, and hardware.



1.6 Uncrating Your Axis (continued)

10

Note: Use team lifting or a power lift to move the unit safely!

Steps to Safely Uncrate Your Axis

6. Remove the lag screws holding down the control stand.
7. Remove any strapping holding the cable conduit in place so there is enough slack to carefully lift and place the control stand next to the crate. Be sure to team lift and be mindful of not putting much tension on the cables.
8. At this point, the Axis should be the only item left on the crate base. Unbolt the Axis from the crate base using a 9/16" socket. A lifting eye is provided to safely and easily lift the Axis off of the crate. A forklift, overhead hoist, or tall engine hoist can lift the 190 lb Axis off of the crate.
9. A furniture dolly can be placed under the control stand and rolled while the Axis is set into position.
Note: If you need to fit the Axis through a single width doorway, you may remove the T-shaped legs from the welded aluminum base by removing the 8 x 5/16"-18 x 1.5" screws. Ensure the head of the Axis is in the DOWN position. This will lower the center of gravity. The Axis can then be lifted and set on an appropriate furniture dolly and rolled through the doorway. Once at the final location, carefully slide the Axis off the dolly and onto the T-shaped legs. Team lifting is advised to balance the machine during this process. Bolt the legs on using the same 8 screws.

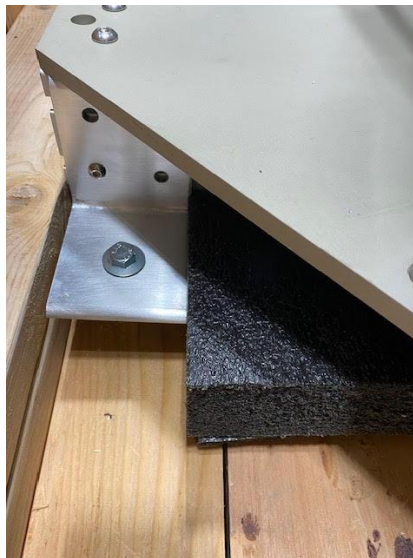

2.1 Defining the System

11

System Definition

This section will highlight and define various sub-systems through the machine.

Sub-systems included:

1. Interlocks, e-stop & motor enable function
2. Light tower function
3. Components



2.1.1 Defining the System

12

Interlocks, E-stop & Motor Enable Function

- Interlocks are simply switches, strategically positioned on your machine, that indicate that the machine is in a safe position for operation.
- There are 3 interlocks that must be satisfied before the motor can be enabled: axial, vertical, and guard.
- The touchscreen interface will indicate which interlocks are satisfied. When all 3 interlocks are satisfied, a blue indicator light will illuminate on the Axis as well as on the light tower.
 - “Pivot Locked” = Axial Interlock
There is an interlock switch to indicate that the pivoting portion of the machine is locked into either of the 2 positions.
 - “Position Low” = Vertical Interlock
The relocating head that moves up and down also indicates an interlock. This ensures that the head is down for operation. This sensor can be affected by a combination of leveling foot height and floor unevenness.
 - “Vessel Engaged” = Guard Interlock
The guard must be installed on the machine and compressed onto a vessel to enable the motor. To satisfy this switch, that mechanism must be fully compressed and fit the vessel concentrically. This sensor can be affected by a combination of leveling foot height and floor unevenness.



2.1.2 Defining the System

13

Light Tower Function

- The light tower indicates the safe operation of the machine so that operators can, from a distance, tell what state the machine is in.
- There are four lights on the tower and each one indicates a different state of the machine. Below is a summary of the different colors and states:
 - Red
 - Indicates E-stop is active, the paddle has stalled or an error state has been detected
 - Yellow
 - Motor enabled
 - All interlocks satisfied then motor enable button pushed
 - Green
 - Running status, wash in progress
 - Blue
 - All interlocks satisfied



2.1.3 Defining the System

14

Axis Trichome Separator and the Control Stand

1. The Axis
 - The Axis contains a frame with legs and a relocating head.
 - Vessels may remain in-place during operation or rolled in-and-out of place for offline filtration.
 - Bruteless vessels of similar or different sizes may be used (30, 44, and 65 gallon only).
 - A quick-change paddle is sized appropriately for each of the 3 standard vessel sizes.
2. The Control Stand
 - This powers the machine, monitors the safety system, and controls the paddle movement.
 - The operator may program patterns and recipes to automate the hash washing process.
 - Patterns are short, discrete paddle movements intended to be looped. A recipe is a combination of one or more patterns, looped for a specific period of time.
 - Most users will have a recipe programmed for each wash cycle. The 1st wash will utilize one or more patterns that are typically gentle and separate only the ripened trichome heads.
 - Subsequent cycles will use recipes with patterns that are more aggressive, separating the “ripe” and ready trichome heads.
 - Final wash cycles are typically utilizing the most aggressive patterns and targeting stubborn, hard to release trichome heads.



2.2 System Dimensions

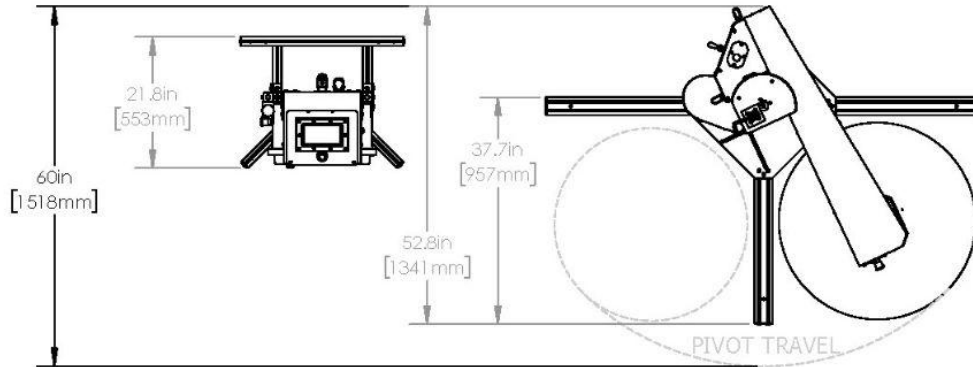

120in Radius [3048mm]
CONTROL STAND
PLACEMENT WINDOW

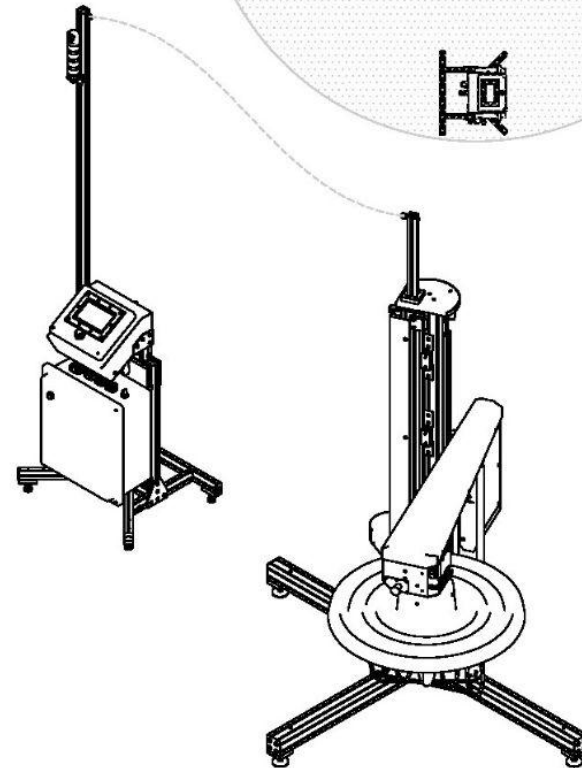
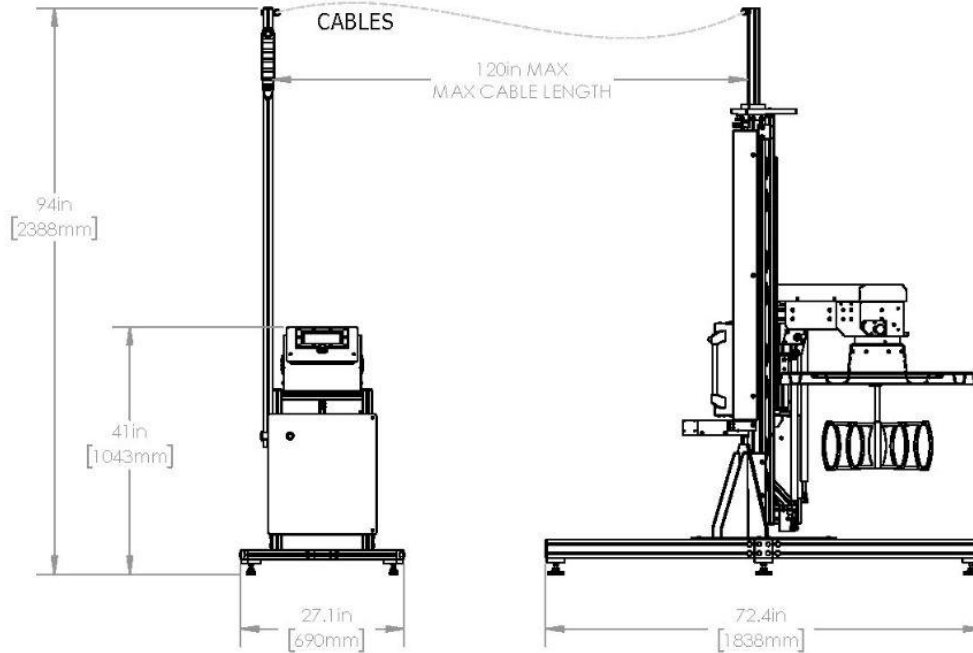
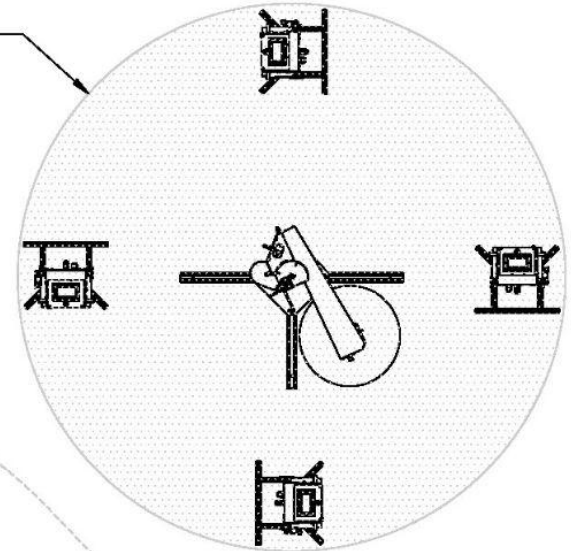

2.3 Basic Movement & Operation

16

- Vertical Movement

- The Axis is designed to raise and lower the relocating head with assistance from a gas spring and a pneumatic cylinder.
- The gas spring supports the weight of the head, while the pneumatic cylinder gently pushes the head in either direction. If air pressure is lost, the head will not rapidly fall since the gas spring is supporting the weight. If pressure is lost during a wash cycle, however, the guard interlock will open, and the wash will halt.
- The movement of the relocating head is controlled by a pneumatic toggle valve. There are three positions the toggle valve can initiate: up, down, and hold.
 - The hold position is useful when aligning the wash vessel with the guard, allowing the operator to hold the head just above the vessel.
 - The lever should be in the down position at all times during the wash cycle.
 - When the lever is left in the up position, the head will lift and eventually lock into the high position with a lift pin. This pin must be held out before lowering the head.

- Axial Movement (Pivot)

- The relocating head can pivot over a vessel and wash a vessel in either of the two pivot positions.
- The pivot pin is for locking the machine in the axial position. If it is not in one of the two operating positions, the interlock will not indicate a safe state, therefore, the motor will not engage.
- An audible snapping noise from the pivoting mechanism will indicate it has locked into position.
- If this pin is not engaged, the vessel may drift during the wash process; the pivot pin must always be locked into one of two positions for operation.

- Joystick Control

- Located on the control stand, the joystick operates the paddle function of the machine.
- The joystick can be operated once all safety interlocks are satisfied and the motor has been enabled.
- A yellow light indicates that the paddle can be operated.
- There are specific screens you must be on in order to operate the paddle. Be sure to check out the touchscreen controls to understand where and how to operate and program your paddle functions.



Lift pin



Pivot pin

2.4 Paddles

17

Sizes, Geometry, and Function

- The paddle geometry has been specially designed for low RPM hash agitation.
- Paddles are sized per the vessel diameters, so the appropriate paddle must be used with the corresponding vessel.
- The precision servo-drive system is ideal to easily repeat gentle motions used for low shear agitation all the way up to aggressive agitation and everything in between.

Quick Disconnect Paddle Coupler

- This is the mechanical component that marries the paddle to the drive shaft.
 - This component can only be installed in one orientation.
 - **Note: Do not try to overpower/rotate the drive shaft with the paddle unless the paddle is fully connected with the lock pin and clamp. Doing so may damage the alignment pin which is not intended to take the full torque of drive system.**
1. Push the paddle onto the shaft and rotate until the internal pin aligns with the keyway (slot) in the drive shaft.
 2. Use the lock pin located on the lanyard to mechanically fix the paddle onto the drive shaft.
 3. Tighten the hygienic shaft clamp to prevent movement between the shaft and paddle coupler. Avoiding this step can cause wear on the paddle coupler and the drive shaft.

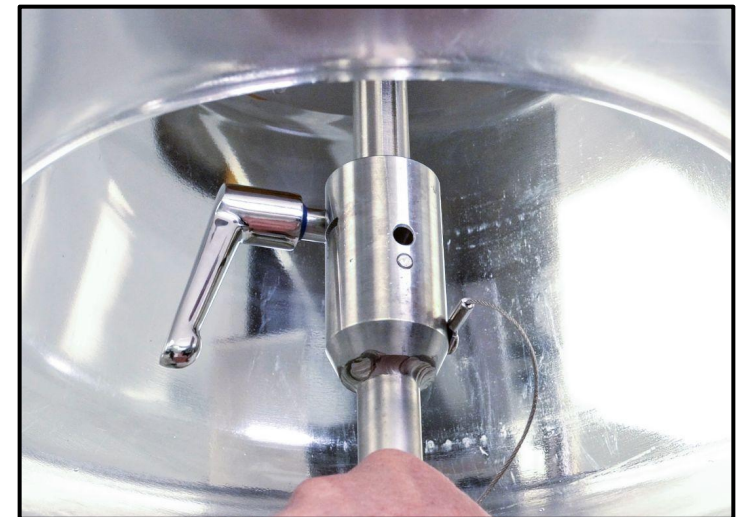

3. Vessel Setup

18

Assembling your Bruteless Vessels is Easy

The following instructions will show you how to set up your Bruteless hash washing system to integrate with the Axis trichome separator.

While each system is design to be used in a certain way, there are opportunities to customize the setup to your liking as you become more familiar with using it. Please refer to the Bruteless User Manual for more information on the different attachments and setups.

We strongly suggest laying out each gasket, tri-clamp, accessories, and other components on a table before beginning setup to ensure that you have all of the parts you'll need in one place.

Before running your first wash, you should first fully clean your vessels, fittings, and hoses. Please refer to the Bruteless User Manual for more information on cleaning instructions. If you need a copy or have misplaced yours, contact us with the information provided below.

Lastly, if you need any help with assembly or want to talk to someone on the team, please contact us at support@gopurepressure.com or give us a call at 720-446-9565 during normal business hours.

3.1 Vessel Setup

19

Note: Remember to clean your equipment and vessels prior to their first use!

Bruteless 65 Gal Center Drain Assembly Instructions

The Axis trichome separator is designed to accommodate any of the three vessel sizes: 30 gallon, 44 gallon, and 65 gallon. The recommended setup for utilizing the Axis trichome separator is with the Bruteless 65 gallon center drain vessel.

Vessel Ports

- The 65 gallon center drain vessel comes with five strategically placed ports.
- Set up your vessel with various fittings and vessel accessories as needed.
- Please refer to the Bruteless User Manual for more information on the different attachments and setups.

Center Drain Port

- The 65 center drain vessel has an integrated taper in the bottom of the vessel to allow better draining of the wash vessel.
- In order to fit with fittings and accessories, a drain ferrule has been added to the middle of the bottom of the barrel.
- You are able to setup various fittings and attachments with this port. See Section 3.2.4 for more details.



3.1.1 Vessel Setup (continued)

20

Note: Remember to clean your equipment and vessels prior to their first use!

Bruteless 30 & 44 Gal Assembly Instructions

The Axis trichome separator can accommodate multiple vessel sizes. The following instructions will highlight the setup for the 30 and 44 gallon vessels.

Vessel Ports

- The Bruteless vessel comes with strategically placed ports.
- The 30 gallon comes with four ports and the 44 gallon with five ports.
- Setup the vessel with various fittings and vessel accessories as needed.

Please refer to the Bruteless User Manual for more information on the different attachments and setups.



3.2 Dolly Setup

21

Bruteless Dolly Assembly Instructions

During the wash process, Bruteless vessels need to travel to a variety of stations during the wash process. From the fill station, to one of the Axis washing locations, the cleaning station, and everything in between, the vessels move throughout the process. Due to this, elevated dollies were created, which quickly mount to the vessel and provide the user with easy transportation of vessels.

For maximum output with the Axis trichome separator, PurePressure recommends to install one of the elevated dollies with each wash vessel.

Each vessel size (65 gallon, 44 gallon, and 30 gallon) has its own matching-sized dolly, with features to allow complete integration into your trichome separator.

The following instructions will show you how to set up your Bruteless dollies to integrate with the Axis trichome separator.



3.2.1 65 Gallon Dolly Setup

22

Bruteless 65 Gallon Dolly Instructions

What's included with setup:

1. (4x) PPM165, Welded Base plate
2. (4x) PPM166, Vessel Spacer plate
3. (2x) PPM167, Vessel Secure plate
4. (4x) PPH179, 5" PU Casters
5. Dolly hardware
 - a. (16x) PPH180, 5/16-18" Dome nut
 - b. (16x) PPH184, 5/16-18" x 7/8" Carriage bolt
 - c. (20x) PPH199, Washer for 3/8" Screw size
 - d. (16x) PPH200, 3/8"-16 x 1" Socket Head bolt
 - e. (4x) PPH201, 3/8"-16" x 1.5" Socket Head bolt
6. **Optional** (1x) PPH202, Center drain support clamp
7. **Optional** Center drain support hardware
 - a. (1x) PPH203, 3/8" x 2" Aluminum spacer
 - b. (1x) PPH204, 3/8"-16 x 2.75" Hex Head bolt

Dolly Features:

- Low-profile design & reduced space claim
- Polyurethane, lab grade swivel casters with lock-in-place brakes
- Maximum load capacity up to 750 lbs
- Easy hardware assembly & disassembly during installation, cleaning, & sanitation
- Center drain support (**optional**), to bear the weight on the central port of the vessel.

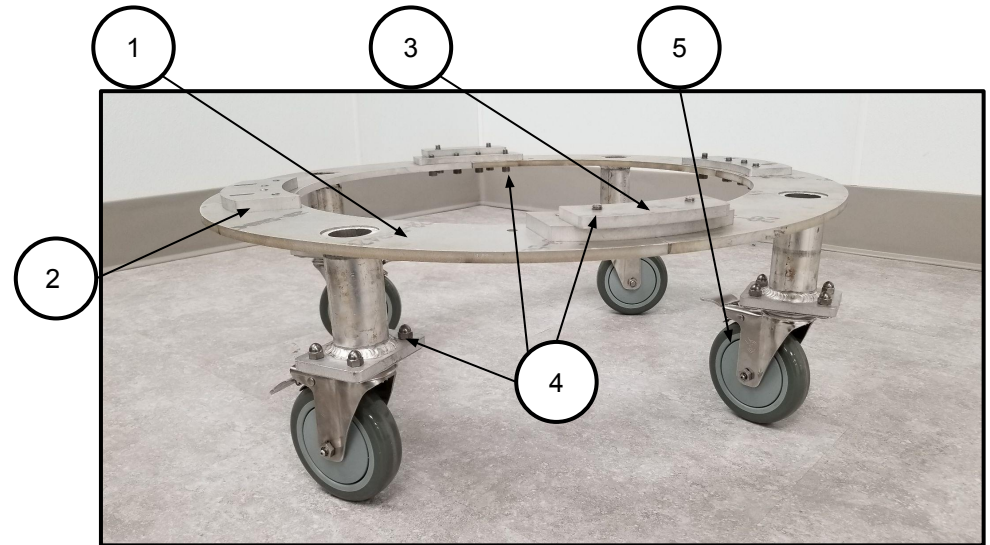

7a

7b

6

3.2.2 65 Gallon Dolly Setup (continued)

23

Note: Remember to clean your equipment prior to use!

Bruteless 65 Gallon Dolly Assembly Instructions

Tools needed for assembly:

- 5/16" allen wrench
- Adjustable wrench or 9/16" Socket Head Drill bit
- Flathead Screwdriver

Assembling dolly:

- Align the four weld plates (PPM165) in a circle.
- Take a spacer plate (PPM166) and align the four holes to secure between two weld plates (PPM165).
- Secure a spacer plate (PPM166) with 1" bolt (PPH200) + washer (PPH199). Ensure hand tight.
- Repeat this for all plates, until four spacer plates are installed. Come back and secure all bolts (PPH200).
- Next, install the center drain support clamp (PPH202). Align the clamp with one of the four holes on the base plate. Attach the clamp through the base plate via hex bolt (PPH202) + aluminum spacer (PPH203)..
 - **Note:** This step is optional, but is recommended for optimal use of the dolly. The clamp can be also installed in any of the four quadrants of the dolly, but the spacer should always be installed below the plate.
- Now, we are ready to secure to the vessel. Obtain a 65-gallon vessel and turn upside down. Flip dolly and align with vessel bottom.
- Take a secure plate (PPM167) and align with two slotted holes on base plate (PPM165) and spacer plate (PPH166)..
- Take a 1.5" bolt (PPH201) + washer (PPH199) and secure. Repeat this for each slotted hole.
 - **Note:** Ensure that the bolts are aligned all the way towards the outside of the barrel.
- Repeat this for a 2nd secure plate (PPM167)
 - **Note:** Ensure that you are 180 degrees from the 1st secure plate.
- The dolly should now be secured to the vessel. Ensure all bolts (PPH201) are tight before moving to next step.
- Lastly, it is time to install the casters (PPH179). Take one caster (PPH179) and align the 4 holes on the bottom of the base plate weldment (PPM165). Take carriage bolts (PPH184), align the dome nuts (PPH180), and secure to base plate weldment (PPM165). Repeat this for all 4 casters.
- Flip dolly and vessel over and get ready to wash!

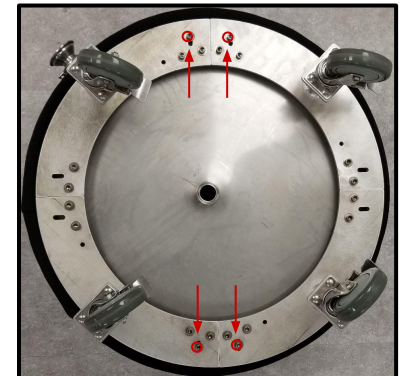
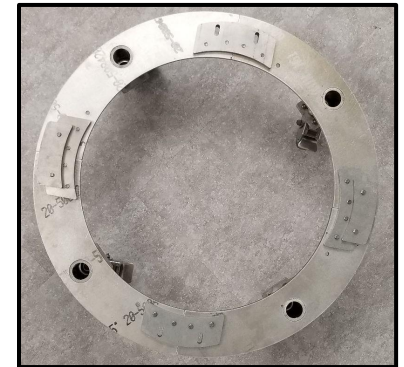

3.2.3 65 Gallon Dolly Setup Schematic

PROPRIETARY & CONFIDENTIAL PROPERTY OF PUREPRESSURE LLC. NO PORTION OF THIS DRAWING/INFORMATION IS TO BE USED OR REPRODUCED WITHOUT WRITTEN PERMISSION.

REVISIONS				
REV.	DESCRIPTION	DATE	DRAWN	APPROVED
A	ASSEMBLY DRAWINGS CREATED	3/23/2021	3/23/2021	B. FIFER

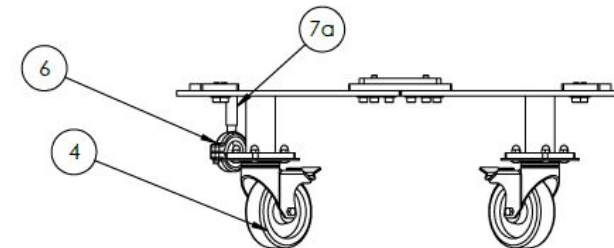
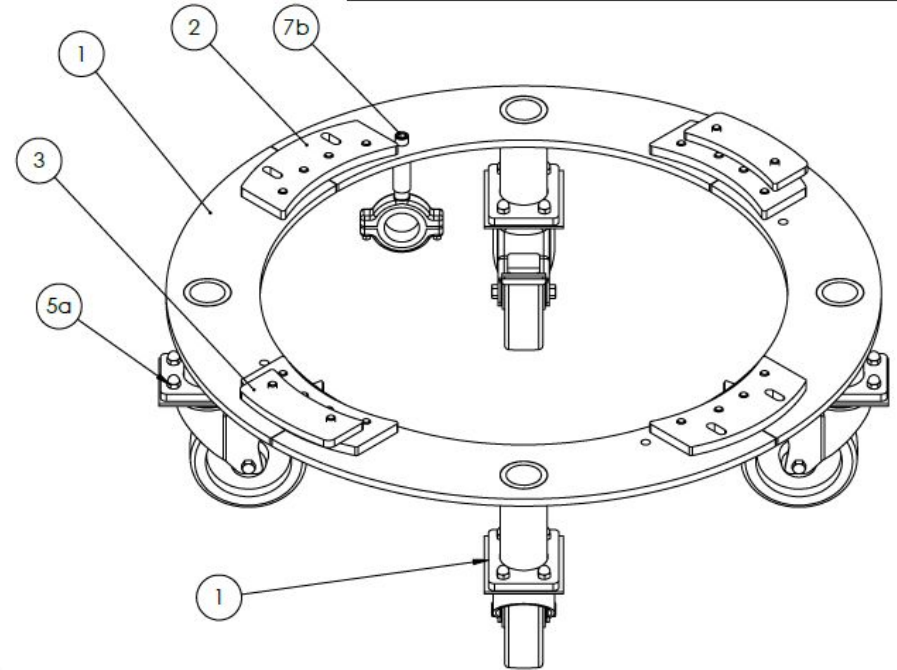
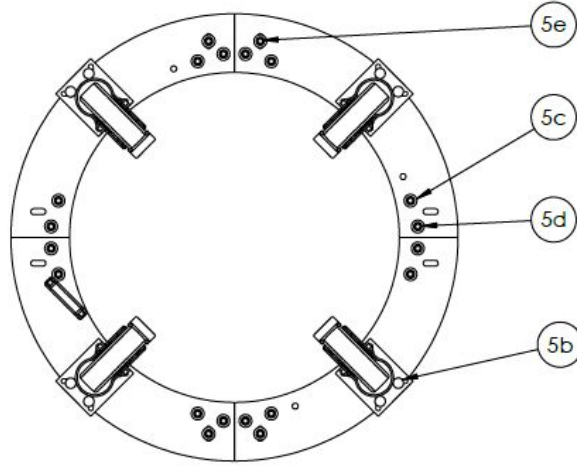

ITEM NO.	Part#	DESCRIPTION	QTY.
1	PPM165	65GAL. Roll, Weldment	4
2	PPM166	Roll&Tilt, Spacer	4
3	PPM167	Roll&Tilt, VesselSecure	2
4	PPH179	5in PU Caster	4
5a	PPH180	18-8 Stainless Steel Cap Nut, 5/16"-18 Thread Size	16
5b	PPH184	18-8 Stainless Steel Square-Neck Carriage Bolt, 5/16"-18 Thread Size, 7/8" Long	16
5c	PPH199	18-8 Stainless Steel Washer for 3/8" Screw Size, 0.406" ID, 0.875" OD	20
5d	PPH200	18-8 Stainless Steel Socket Head Screw	16
5e	PPH201	18-8 Stainless Steel Socket Head Screw	4
6	PPH202	Washdown Threaded-Rod-Mount Clamping Hanger	1
7a	PPH203	Aluminum Unthreaded Spacer, 3/4" OD, 2" Long, for 3/8" Screw Size	1
7b	PPH204	18-8 Stainless Steel Socket Head Screw	1

DESCRIPTION:
65GAL. ROLLING
DOLLY ASSY



PRODUCT: PPF014 - 65GAL. Roll Dolly, Assembly

DRAWN: B. FIFER 3/23/2021
SHEET: 1 OF 2

REV: A

3.2.4 65 Gal Center Drain Setup

25

Bruteless 65 Gal Center Drain Assembly Instructions

One of the new features of the Axis setup is the 65 Gal Center drain vessel.

To fully utilize the center drain properties, we recommend to use the following setup:

- First, gather a 65 gallon center drain vessel and ensure there is a 65 gallon dolly attached. See Section 3.2.2 for dolly attachment instructions.
- Ensure the center drain support clamp is installed. If not, install in any of the quadrants of the dolly. See 3.2.2 for additional information.
- Once dolly and center drain supports are installed, we are ready to outfit the port.
 - a. Attach a 90-degree elbow to the center drain. Secure it with a clamp and a gasket.
 - b. Once the elbow is secured, install a 12" straight pipe to the 90 degree elbow, tightening it with a clamp and a gasket.
 - c. Fit the straight pipe through the clamp. Secure the clamp tight with a flat-head screwdriver.
 - d. Lastly, attach a ball valve to the end of the straight pipe and secure with a clamp and a gasket.
 - e. Connect the end of the ball valve to your filtration setup and you are ready to wash!

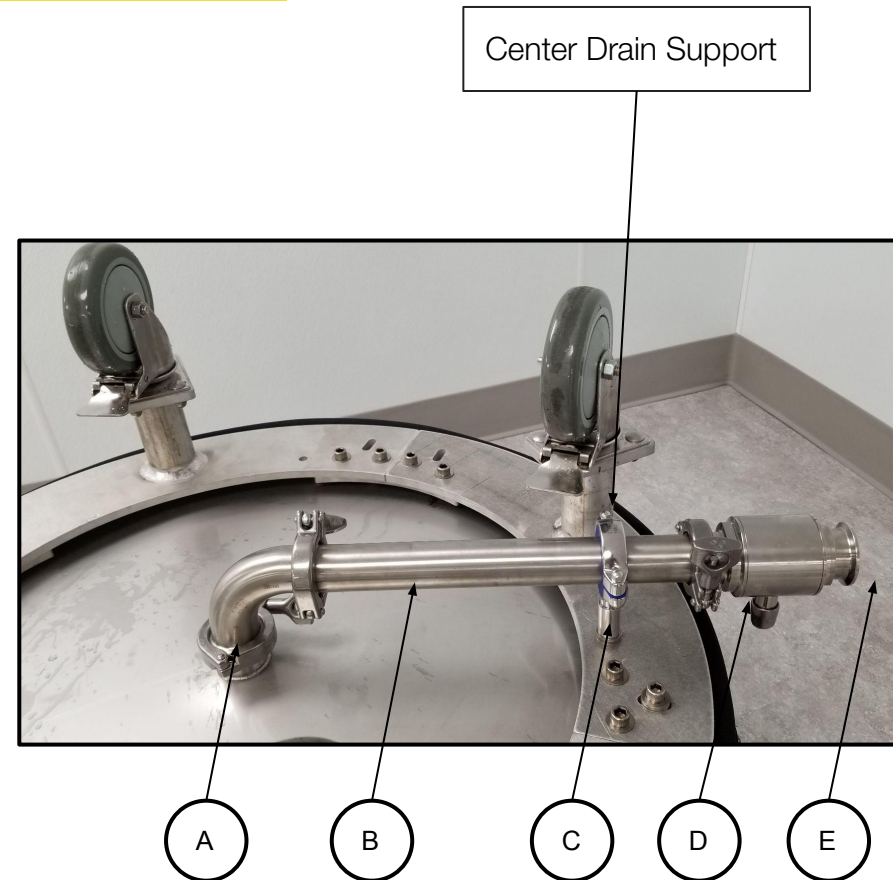

3.2.5 30/44 Gallon Dolly Setup

26

Note: Remember to clean your equipment prior to use!

Bruteless 30/44 Gallon Dolly Assembly Instructions

What's included with setup:

1. (2x) PPM169 or PPM171, Base Tilt plate
2. (2x) PPM168 or PPM170, Base Non-tilt plate
3. (4x) PPM166, Vessel Spacer plate
4. (2x) PPM167, Vessel Secure plate
5. (4x) PPH205, 3" PU Casters
6. Dolly hardware
 - a. (16x) PPH180, 5/16-18" Dome nut
 - b. (16x) PPH184, 5/16-18" x 7/8" Carriage bolt
 - c. (20x) PPH199, Washer for 3/8" Screw size
 - d. (16x) PPH200, 3/8"-16 x 1" Socket Head bolt
 - e. (4x) PPH201, 3/8"-16" x 1.5" Socket Head bolt
7. *****30 gallon ONLY*****
 - a. (4x) PPM172, Vertical Spacer plate
 - b. (16x) PPH198, 5/16-18" x 1.5" Carriage Bolt
8. **Optional:** Vessel Tilt mechanism (not shown)

Dolly Features:

- Low-profile design & reduced space claim
- Polyurethane, lab grade swivel casters with lock-in-place brakes
- Maximum load capacity up to 750 lbs
- Easy hardware assembly & disassembly during installation, cleaning, & sanitation

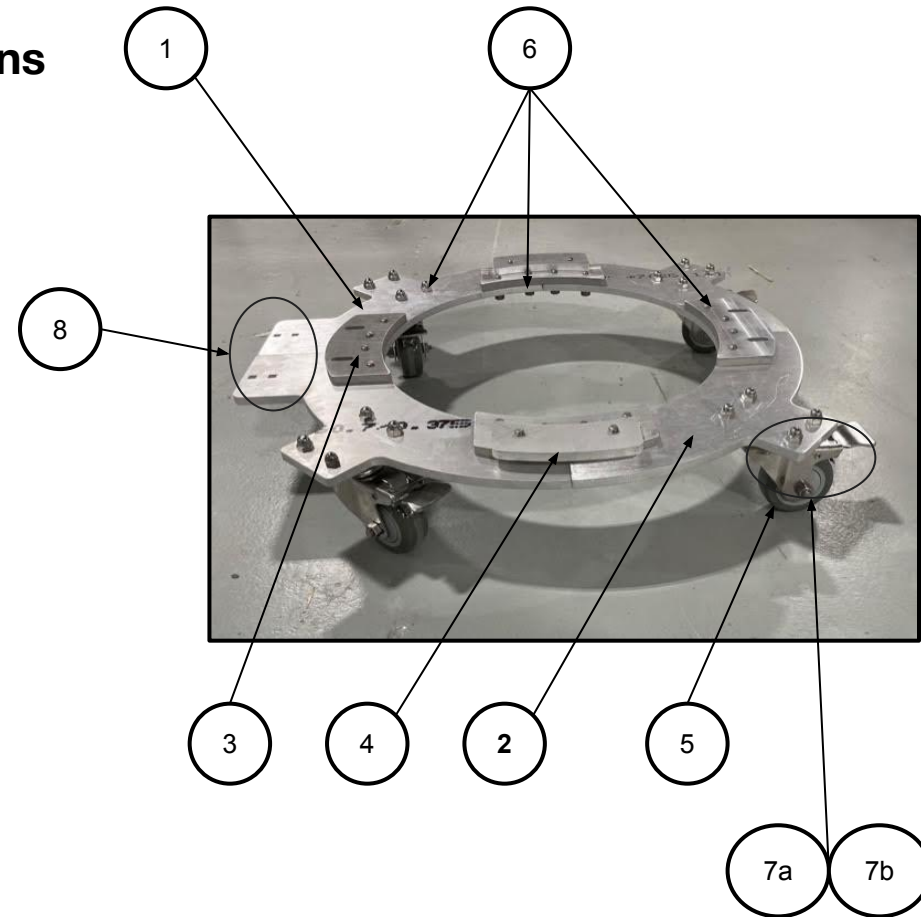

3.2.6 30/44 Gallon Dolly Setup

27

Bruteless 30/44 Gallon Dolly Assembly Instructions

Tools needed for assembly:

- 5/16" allen wrench
- Adjustable wrench or 9/16" Socket Head Drill bit

Assembling dolly:

- Align the 4 x weld plates in a circle. The two tilt plates (PPM169/PPM171) should be connected together and the two non-tilt plates (PPM168/PPM170) should be connected together.
 - **Note:** Align the tilt plate in-line with the fill port (opposite the drain port).
- Take a spacer plate (PPM166_) and align the 4 holes to secure between 2 weld plates.
- Secure spacer plate (PPM166) with a 1" bolt (PPH200) + washer (PPH199). Ensure hand tight.
- Repeat this for all plates, until 4 spacer plates are installed. Come back and secure all bolts (PPH200)
- Now, we are ready to secure to the vessel. Obtain a 44-gallon or 30-gallon vessel and turn upside down. Flip dolly and align with vessel bottom.
- Take a secure plate (PPM167) and align with 2 slotted holes on base plate.
- Take 1.5" bolt (PPH201) + washer (PPH200) and secure to base weldment. Repeat this for each slotted hole.
 - **Note:** Ensure that the bolts are aligned all the way towards the outside of the barrel.
- Repeat this for a 2nd secure plate, ensuring that you are 180 degrees from the 1st secure plate. The dolly should be secured to the vessel. Ensure all bolts are tight before moving to next step.
- Lastly, it is time to install the casters (PPH205). Take one caster and align the 4 holes on the bottom of the base plate weldment. Take carriage bolts (PPH184), align the dome nuts (PPH180), and secure to base plate weldment. Repeat this for all 4 casters.
 - **Note:** For the 30 gallon dolly, a vertical height extension plate (PPM172) goes between the caster and the base plate. Due to this, you will need to use longer carriage bolts (PPH198) to secure to casters.
- Flip dolly and vessel over and get ready to wash!

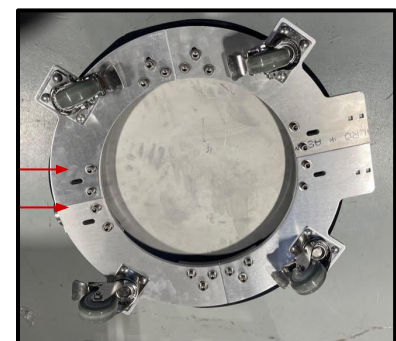

3.2.7 44 Gallon Dolly Schematic

PROPRIETARY & CONFIDENTIAL PROPERTY OF PUREPRESSURE LLC. NO PORTION OF THIS DRAWING/INFORMATION IS TO BE USED OR REPRODUCED WITHOUT WRITTEN PERMISSION.

REVISIONS				
REV.	DESCRIPTION	DATE	DRAWN	APPROVED
A	ASSEMBLY DRAWINGS CREATED	3/23/2021	3/23/2021	B. FIFER

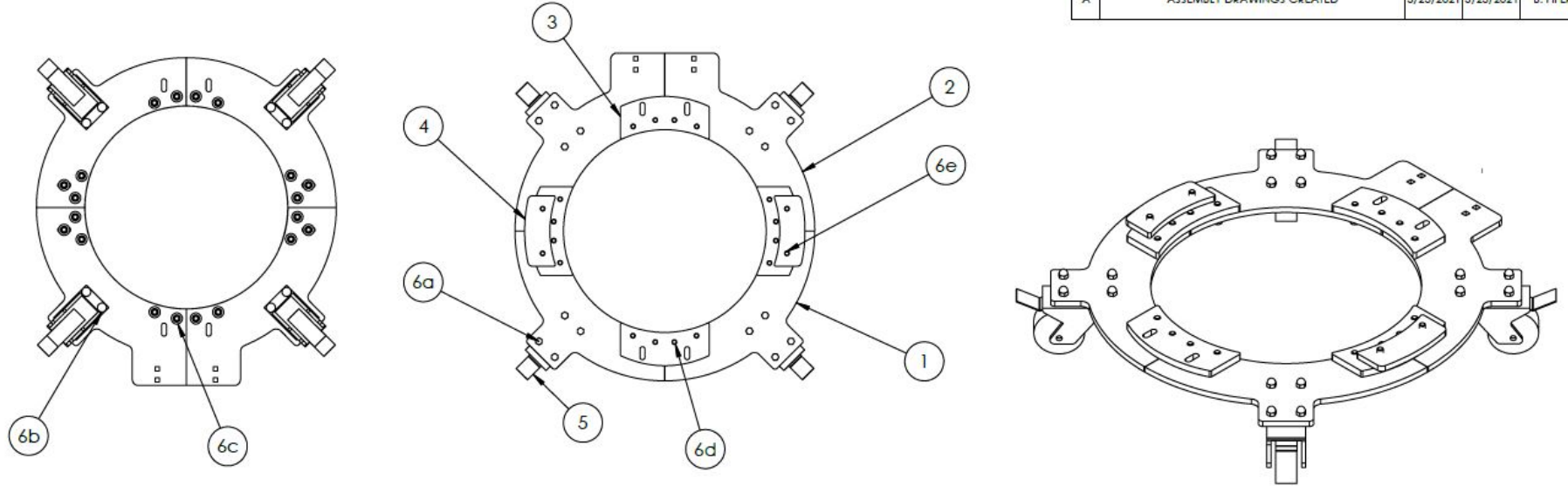

ITEM NO.	Part#	DESCRIPTION	QTY.
1	PPM168	44GAL, Roll&Tilt, Plate	2
2	PPM169	44GAL, Roll&Tilt, Tilt Plate	2
3	PPM166	Roll&Tilt, Spacer	4
4	PPM167	Roll&Tilt, VesselSecure	2
5	PPH205	3" Stainless Steel Swivel Caster - Non Marking Gray Polyurethane Wheel with Total Lock Brake	4
6a	PPH180	18-8 Stainless Steel Cap Nut, 5/16"-18 Thread Size	16
6b	PPH184	18-8 Stainless Steel Square-Neck Carriage Bolt, 5/16"-18 Thread Size, 7/8" Long	16
6c	PPH199	18-8 Stainless Steel Washer for 3/8" Screw Size, 0.406" ID, 0.875" OD	20
6d	PPH200	18-8 Stainless Steel Socket Head Screw	16
6e	PPH201	18-8 Stainless Steel Socket Head Screw	4

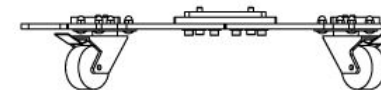

DESCRIPTION: ROLL&TILT, 44GAL, ASSY	 PUREPRESSURE 2625 S. Santa Fe Dr. Unit 1-1 DENVER, CO 80221	PRODUCT: PPF015 - 44GAL, Roll&Tilt Dolly, Tilt Assembly
		DRAWN: B. FIFER
		3/23/2021
SHEET: 1 OF 1		REV: A

3.2.8 30 Gallon Dolly Schematic

PROPRIETARY & CONFIDENTIAL PROPERTY OF PUREPRESSURE LLC. NO PORTION OF THIS DRAWING/INFORMATION IS TO BE USED OR REPRODUCED WITHOUT WRITTEN PERMISSION.

REVISIONS				
REV.	DESCRIPTION	DATE	DRAWN	APPROVED
A	ASSEMBLY DRAWINGS CREATED	3/23/2021	3/23/2021	B. FIFER

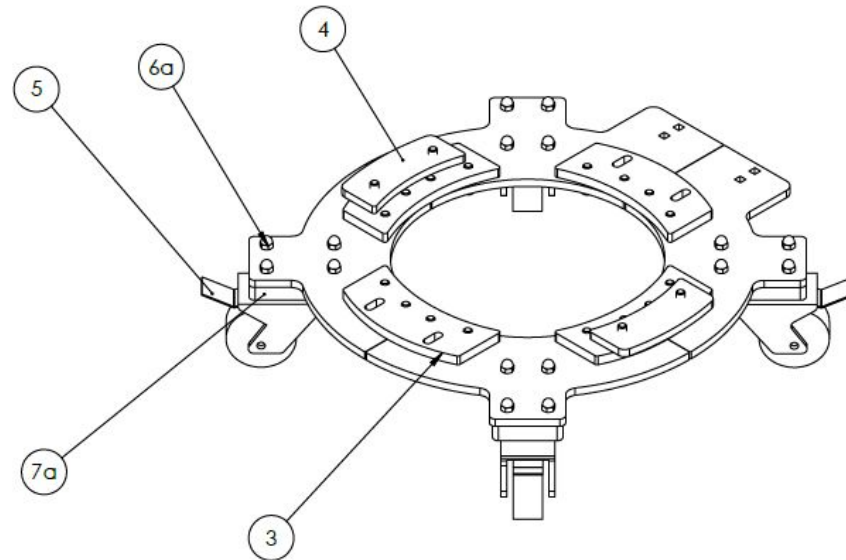
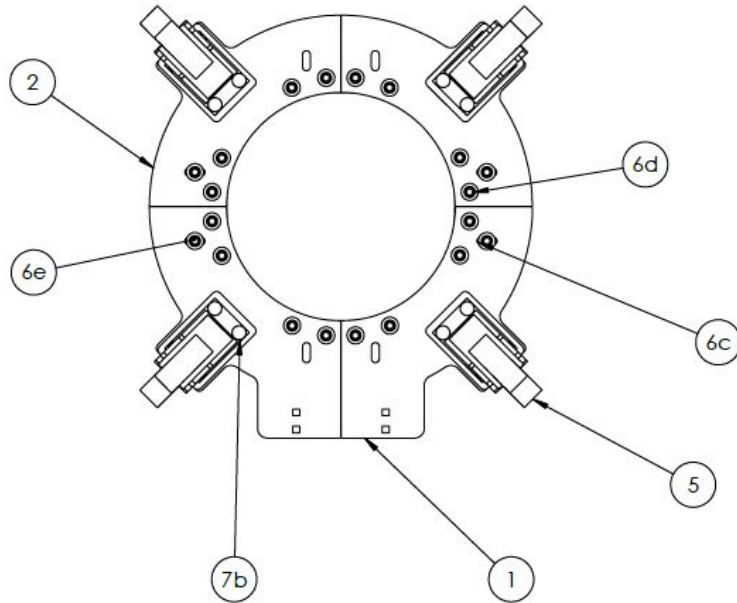

ITEM NO.	Part#	DESCRIPTION	QTY.
1	PPM171	30GAL, Roll&Tilt, Tilt Plate	2
2	PPM170	30GAL, Roll&Tilt, Plate	1
3	PPM166	Roll&Tilt, Spacer	4
4	PPM167	Roll&Tilt, VesselSecure	2
5	PPH205	3" Stainless Steel Swivel Caster - Non Marking Gray Polyurethane Wheel with Total Lock Brake	4
6a	PPH180	18-8 Stainless Steel Cap Nut, 5/16"-18 Thread Size	16
6c	PPH199	18-8 Stainless Steel Washer for 3/8" Screw Size, 0.406" ID, 0.875" OD	20
6d	PPH200	18-8 Stainless Steel Socket Head Screw	16
6e	PPH201	18-8 Stainless Steel Socket Head Screw	4
7a	PPM172	30GAL, Roll&Tilt, ExtensionPlate	4
7b	PPH198	18-8 Stainless Steel Square-Neck Carriage Bolt, 5/16"-18 Thread Size, 1-1/2" Long	16

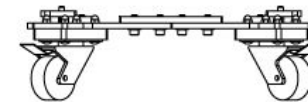

DESCRIPTION:
ROLL&TILT, 30GAL,
ASSY

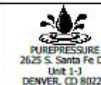

PRODUCT: PPF016 - 30GAL, Roll&Tilt Dolly, Tilt Assembly

DRAWN: B. FIFER
SHEET: 1 OF 1

3/23/2021

REV: A

3.3 Insulation Adjustment

30

Adjusting insulation for guard fitment

One of the key features to help with regulating water temperature is the closed-cell foam insulation. Each Bruteless vessel comes with an antimicrobial neoprene sleeve encompassing closed-cell foam. This layered construction helps dramatically reduce ice usage by up to 50% and is easily removable for cleaning.

Due to manufacturing, the insulated sleeve may bunch up near the lid of the vessel. To ensure optimal use with the trichome separator, it is recommended to inspect and adjust this bunch-up, especially after reinstalling the sleeve post-cleaning. This is to ensure proper guard fitment.

If you wish to further customize the fitment of the insulation with the guard, you may also peel back the neoprene, trim the foam insulation and tuck the neoprene back over the insulation.



4. Axis Setup

31

Setting Up the Axis Trichome Separator is Easy

After uncrating the Axis and setting up the vessels & dollies, we are now ready to setup the machine. The following pages will show you how to set up your Axis trichome separator.

While each laboratory is laid out in its own unique way, we strongly suggest following these instructions to get started right away.

If you need any help with assembly or want to talk to someone on the team, please contact us at support@gopurepressure.com or give us a call at 720-446-9565 during normal business hours.



4.1 Cable Management

Cable Management and Wiring Routing Setup

- First, you need to decide a desired location to setup the Axis.
- Now that the Axis has been placed in its final position, you may route the cable conduit so that it is secured out of the way of the operators.
 - Place the control stand in your desired location. You may utilize the extra conduit length which is coiled and clipped onto the back of the control stand. An ideal position should allow the operator to view the inside of both vessels with quick and easy access to the head controls so the operator can raise, pivot and lower the machine without any obstructions or trip hazards.
 - Remove the lifting eye from the threaded block on the top of the Axis. Do NOT remove the threaded block. The lifting eye is easily removed by placing a screwdriver or wrench in the eyelet and turning counterclockwise.
 - Using a flathead screwdriver, install the threaded insert (supplied in the hardware bag) into the same hole that the lifting eye came out of. The top of the insert should be flush with the threaded block.
 - Locate the threaded stud in the hardware bag and thread half-way into the bottom of the provided cable support post.
 - Then, thread the cable support post into the threaded block on top of the Axis. Using channel locks, tighten the post so it is secure.
 - Install the provided cable support eyelets, one on the Axis and one on the control stand so that the eyelets face each other.



4.1.1 Cable Management (continued)

33

Cable Management and Wiring Routing Setup

- Using a small phillips screwdriver to loosen the rope clamp, adjust the length of the cable support rope so it is taught between the Axis and the control stand. You may tuck the extra rope into the slot on the support post or cut to length and singe to prevent fraying.
- Starting at the Axis, zip tie the conduit to the cable support rope. Work your way back towards the control stand. Ensure that the conduit maintains at least a 5" bend radius during final installation.
- Continue to anchor the conduit down the cable support post on the control stand.
- Coil the remaining conduit and clip into place.
- Run the Axis power cord to the supplied electrical outlet. An ideal location is directly above the control stand.
- Run a pneumatic supply to the supplied regulator on the back of the control stand. Ideally this would also be run to a ceiling connection. The Axis requires 120 psi of dry compressed air. The air consumption is less than 1 cfm and is generally negligible. Just ensure that the pressure is maintained, and the machine will function properly.



4.2 Compressed Air Supply

34

Note: When raising the cross arm during operation, be sure that the paddle clears the vessel before pivoting the head.

How to Setup the Air Supply

- Compressed air is required to operate the pneumatic cylinder that moves the cross arm up, down, and holds the cross arm in position.
- The pneumatic filter-regulator on the back of the control stand has a standard industrial male quick connect fitting.
 1. **Place the toggle lever into the hold position.**
 2. Connect the dry compressed air source and validate that you have 120 psi.
 3. Now, the cross arm can be operated by using the toggle switch on the Axis.
 4. The middle position will hold the head.



4.3 Guard Installation

35

Note: Ensure you have already assembled and installed a PurePressure raised dolly onto a Bruteless vessel before this section.

How to Properly Install the Vessel Guard

1. Roll the vessel into one of the two wash positions, making sure the head is locked into the position over the vessel and no paddle is attached.
2. Place the guard on top of the vessel.
3. Lower the head of the axis and mate it with the guard. The D-shape of the guard and the receiving portion of the agitator should nest together in one position.
4. Use (qty. 3) ¼-20 x 1" flanged hex head screws and a ⅜" nut driver tool to install the guard.
5. Raise the relocating head, the paddle can now be installed.

Check Functionality with the Control Panel

- Lower the head so the guard engages the vessel. There is a spring-loaded mechanism located in the relocating head at the guard. It must be fully compressed on the vessel to operate the machine. If listen for a low metal-on-metal sound when the head compresses.
- You should see a blue indicator light illuminate when all 3 interlocks are satisfied. You can now enable the motor and operate the paddle.

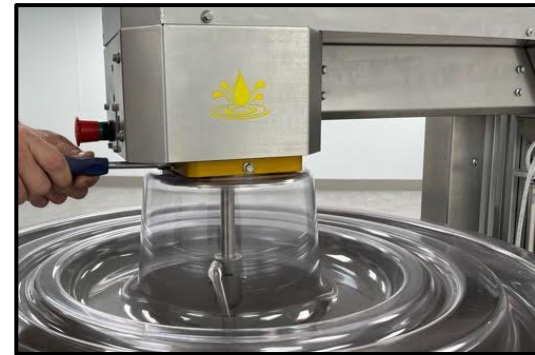

4.4 Leveling the Axis

36

Setting Machine Height for Operation

- Parallel vs. Level
 - Not all floors are level and the Bruteless vessels are on a rolling dolly, which can be oriented in any direction when loaded into the Axis.
 - This means that you cannot effectively level the vessel to the floor. Since the Bruteless vessel will be parallel to the floor, we need to make sure that the Axis is parallel to the floor as well.
 - This will ensure proper vessel engagement and ensure the interlocks are satisfied every time you load a vessel for a wash cycle.
- The Axis has leveling feet that can account for up to +/- 1/2" of uneven floor surface. It is important to have your machine, mainly your guard, parallel with the top of your vessels so that it can consistently mate with the vessel.
- Here are a few things to think about while choosing an operating location for your machine:
 - First and foremost, when positioning your Axis machine, ensure that the operating footprint is strategically positioned for your production workflow.
 - Be aware that floors near a drain have grade for draining. If you want to position your system near or over a floor drain, try to center the machine symmetrically over the drain.
 - Before adjusting the leveling feet, have your air system hooked up so that you can easily raise and lower the relocating head. This will be done several times to verify the guard is properly compressing on your vessel.

Leveling Feet Identification

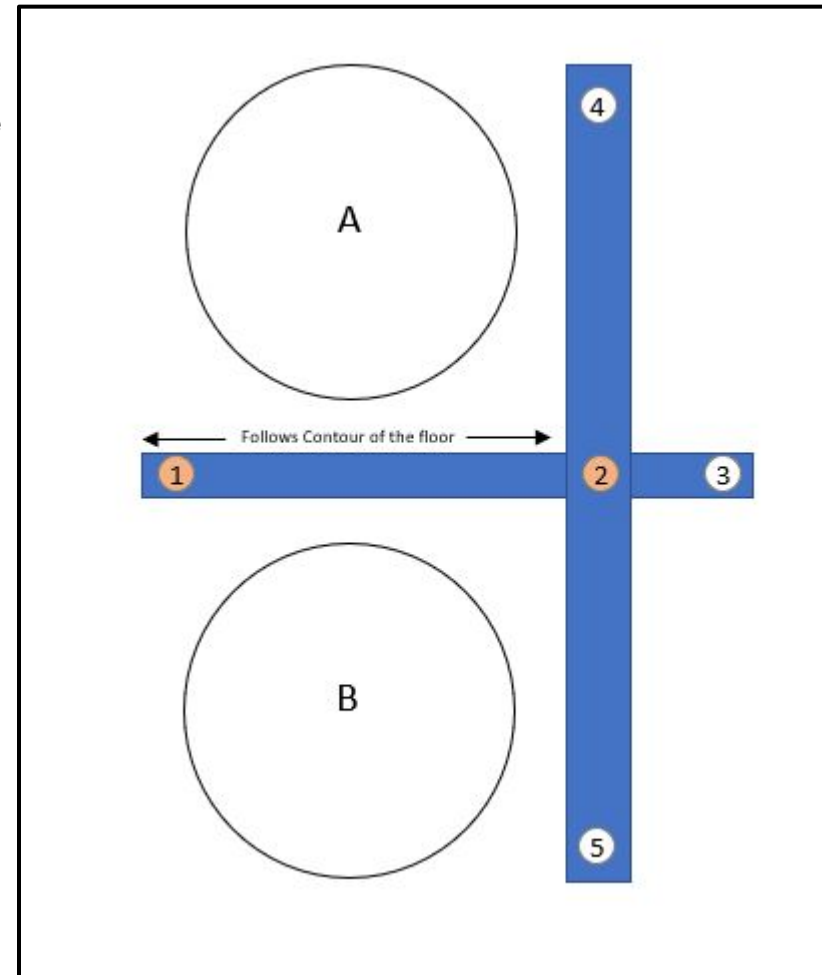

4.4.1 Leveling the Axis (continued)

37

Setting Machine Height for Operation

- Follow these instructions for setting the Axis height and angle with the leveling feet:
 - Remove the enclosure faceplate above the guard, from here you can view the spring-loaded parts that control the guard safety function also known as the guard interlock. These two plates need to be fully compressed when engaged with a vessel to satisfy the safety interlock.
 - The leveling feet are set from the factory with a $\frac{1}{2}$ " gap between the two nuts. See image.
 - To adjust each leveling foot, first loosen (upper) the jamb nut that is against the aluminum leg. Use the lower hex nut at the base of the stem to adjust the leveling foot height. Loosen to raise, tighten to lower the machine. Do not re-tighten the jam nuts until you are finished with setting the machine, this will avoid extra work.
 - Start by raising leveling foot #2 fully. This is a support foot only and not used during the paralleling process.
 - Gently push on the legs of the machine to try and make it teeter. Find out where the low spots in the floor are located.
 - Check leveling feet #1 & #3 to see they are in contact with the floor or floating. If they are floating, lower #1 & #3 until they just touch the floor.
 - If #1 & #3 are in contact with the floor, raise them just until #4 & #5 are both in contact with the floor.
 - Now, wheel the two vessels into position. Lower the head to engage the vessel and lock the casters in place. Now inspect the guard around the entire circumference of the vessel to verify that the guard is fully engaging the vessel. Do this for each position.

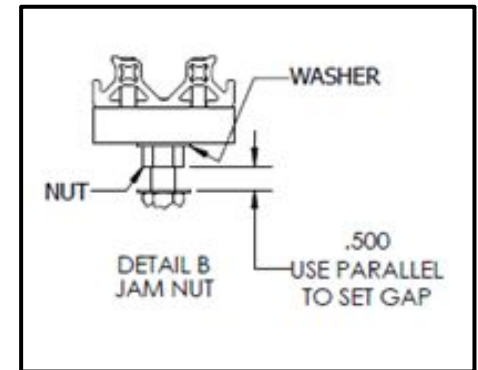

4.4.2 Leveling the Axis (continued)

38

Setting Machine Height for Operation

- Follow these instructions for setting the Axis height and angle with the leveling feet:
 - Next, inspect the interlock plates as they need to be fully compressed. If they are not, then the machine needs to be lowered or the angle needs to be adjusted. This will ensure that the guard interlock is fully engaged for operation.
 - The ideal engagement will leave no gap between the interlock plates.
 - If there is a gap and it is even across the interlock plates, then the entire machine needs to be lowered equally.
 - If the gap is uneven, observe the gap front to back and side to side to adjust the leveling feet accordingly to first make the gap even and then lower the machine to reduce the gap to zero.
 - If there is a very small gap in these plates, a rattling noise can be caused from the vibrations of the machine, causing an undesirable noise. This will not damage the machine but will likely lead to confusion and a service call as it can sound like something is rubbing. The compression force from the pneumatic cylinder will eliminate any rattling when the leveling feet are adjusted properly.
 - If one vessel is engaging and the other is not adjusting feet 4 or 5 to have both engaging evenly. Do this by lowering the high side, also adjust 1, 2 & 3 as needed so all leveling feet are equalized.
 - Tighten the jam nuts against the aluminum profile to preserve the machine height and reinstall the enclosure faceplate. Your machine height is now set for operation.

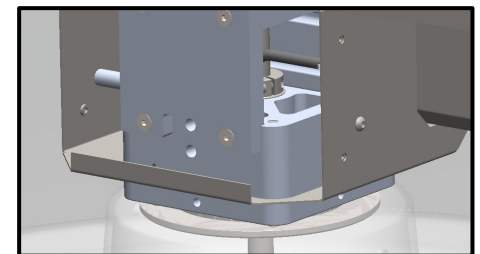
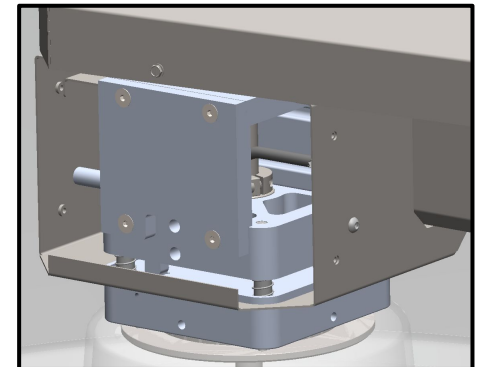
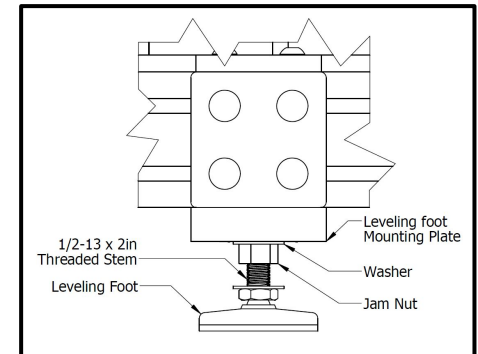

4.5 Filtration Wash Liner Installation

39

Preparing the Liner for Operation

- The filtration wash liners are uniquely designed to be used with the Axis. The product is intended to manage the largest portion of cannabis biomass waste during the process, allow for trichomes movement and does not interfere with the paddle or the processing methods familiar to the industry. The dowels used in the design expand the filtration media inside the vessel so that there is a void between the liner and the vessel wall. This allows room so that trichomes have a place to flow outward and settle to the bottom.
- There are 3 sizes available to match the vessels that can be used with the Axis machine (**30 gallon, 44 gallon, & 65 gallon**).
- ONLY USE THE CORRECT SIZED LINER WITH THE MATCHING VESSEL, OTHERWISE ENTANGLEMENT DAMAGE COULD OCCUR TO THE WASH LINER.
- ONLY UTILIZE PUREPRESSURE WASH LINERS WITH THE INCLUDED DOWEL ROD FOR OPERATION. ALWAYS UTILIZE THE LOWER ROD AT MINIMUM.



4.5.1 Filtration Wash Liner Installation (continued)

40

Installing a Wash Liner into a Vessel

There are 2 food grade dowels included with each liner, which will need to be installed, as they are not inserted prior to shipping to avoid damage. There are pros and cons to using 1 versus 2 dowels. With both dowels inserted into the liner, the operator decreases the likelihood of improperly installing the wash liner into the vessel. In an unlikely scenario, an improperly installed liner can snag and tear on the paddle during the wash. On the other hand, using both dowels can be cumbersome during the rinsing process after draining a vessel. You may find that you are fighting the upper dowel while trying to access the vessel walls during spraydown. Utilizing only the lower dowel gives the operator the flexibility to bunch the bag at the top during the spraydown process, increasing vessel wall access and decreasing stress on the wash liner. It is ultimately up to the user to decide which option suits their needs best.

1. The dowel is to be installed and operated on the outside of the filter bag, not the inside.
2. Thread the rod through all the dowel loops and utilize the connector sleeve to connect the two ends of the dowels. This rod will hold a diameter that matches the inside of your vessel.
3. Drop the expanded liner into the vessel bottom. Be sure that your false bottom is installed before hand.
4. The white canvas material at the top of the filtration liner is referred to as the collar. It is meant to be wrapped around the top of the vessel. Pull it around the vessel evenly when installing. Work it around the vessel a little extra so that inside the bottom is floating 1-2in above the false bottom.
5. Next push back down, using your hands, around the inside circumference of the vessel to nest the dowel down flush with the false bottom. This process should make the bottom and sidewalls all taught. The liner should not be twisted or loose inside the vessel. Last tighten the draw cords around the outer wall of the vessel. Now is ready for material, ice and water.
6. **Cleaning and Care** - We recommend you thoroughly rinse filtration wash liners both flipped inside and out with water before and after every wash. Utilize the lifting straps for hang drying.

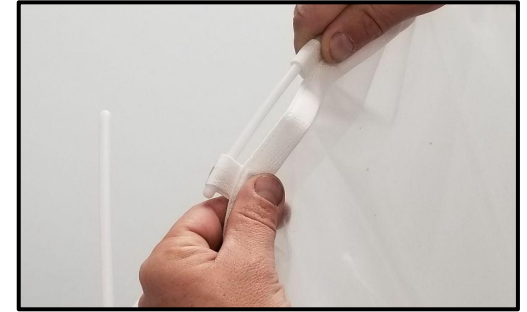

5. Axis Touchscreen Interface

41

Note: PurePressure's Pressware has been designed and engineered specifically for solventless cannabinoid oil extraction.

Touchscreen Interface Overview

The Axis comes integrated with a touchscreen to help control and program an automated hash washing process. The servo-driven paddle may be controlled using the included joystick or motion can be programmed using the touchscreen interface.

The motor motion is captured in a pattern. A pattern consists of motor movement for a maximum of 30 seconds. Patterns are intended to be looped for a specified amount of time. Quick Wash lets you select a pattern on the fly and start washing right away. Your pattern selections and wash times will be recorded for you to save as a recipe.

Recipes consist of one or more patterns and may include a dwell (rest period). Recipes may be created manually or using Quick Wash and can be edited/customized as you wish.

In the following sections, we will cover exactly how to use your Pressware controls and how you can get the most out of your Axis Trichome Separator.



Note: Some screens and features are not available unless the motor is enabled. Be sure to have a vessel in place and enable the motor before attempting to engage paddle motion.

5.1 Home Screen

The Home Screen appears after startup and you can navigate to most places from the home screen. The upper portion of the screen is persistent and will indicate the status of the most important items including interlock switches and paddle movement.

1: Status Bar

Indicates instructions to the operator as well important information, prompts, and warning messages.

2: Interlock Switch Status

Indicates the status of each interlock switch.

3: Motor Enable

Indicates the status of the motor enable switch controlled by the motor enable button on the front of the control panel.

4: Live Paddle Motion

Live readouts of the paddle revolutions per minute (RPM) and direction.

5: Joystick Settings

Control the motion of the paddle with ease by setting the max RPM of the joystick (speed limit) and the ramp (acceleration).

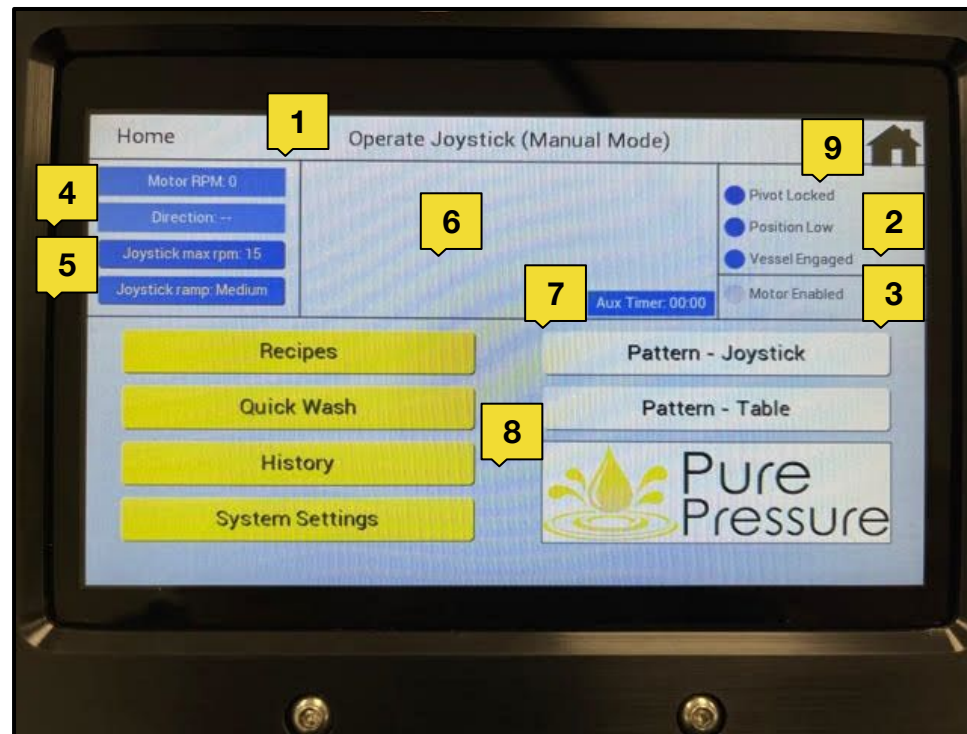

9: Home

Return back to the home screen. This button is available on every screen.

6: Current Pattern/Recipe

View information on the current pattern and recipe.

7: Auxiliary Timer

A convenient digital timer for anything in your process.

8: Navigation Buttons

Use these buttons to navigate to the appropriate screen.

Recipe = View, edit, and create recipes

Quick Wash = Select a pattern(s) on the fly and start washing immediately

History = View a history of recipes completed, as well as batch information, so you can keep track of multiple vessels at one time

System Settings = Control various settings and view maintenance schedule

Pattern - Joystick = Create a pattern using the joystick

Pattern - Table = Create a pattern by programming paddle RPM, direction, and time

PurePressure = View contact information and current firmware version

5.2 Joystick Patterns

43

Note: Use the fast setting with caution to avoid damaging your material or to prevent breaking up the ice with the paddle.

Joystick patterns allow the operator to create complex paddle motion that would otherwise be difficult to program manually as you might do in a table pattern.

To record a joystick pattern follow these steps:

1. Adjust the Joystick Max RPM and Ramp using the provided buttons located at the red arrow.

Joystick Max RPM – This is the speed limit of the joystick (2 – 80 RPM). When you twist all the way in one direction or the other, this is the speed the paddle will rotate at. You will still be able to reduce the speed using “partial throttle” movements of the joystick. Typical patterns will range from 10 to 50 rpm. Note: Operating above 50 rpm may damage your flower or break up the ice unnecessarily. This type of motion is generally not needed but in typical PurePressure fashion we give you full control.

Joystick Ramp – This is the setting that controls the acceleration of the paddle. Choose between slow, medium and fast.

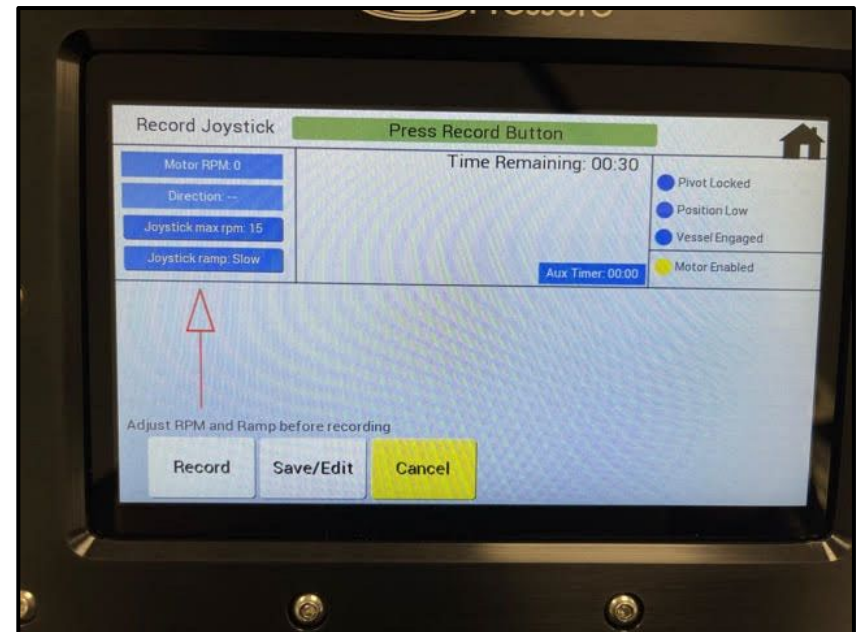

Ramp	Description
Slow	Good for gentle paddle motion, slow direction changes, and minimal paddle impact.
Medium	Good for moderate to heavy agitation
Fast	Will induce aggressive directional changes for working out the last bits of hash in stubborn material

5.2.1 Joystick Patterns (continued)

44

2. Press “Record”; the system will wait for you to move the joystick before it will start recording paddle motion.
3. Once recording is started, you will see a countdown timer for 30 seconds. You may use the entire 30 seconds or you may press “Stop” when you are finished.
4. Once complete, you may save the pattern by selecting an open location.
5. To use a joystick pattern, use the Quick Wash feature or program a recipe using the pattern you have just created.

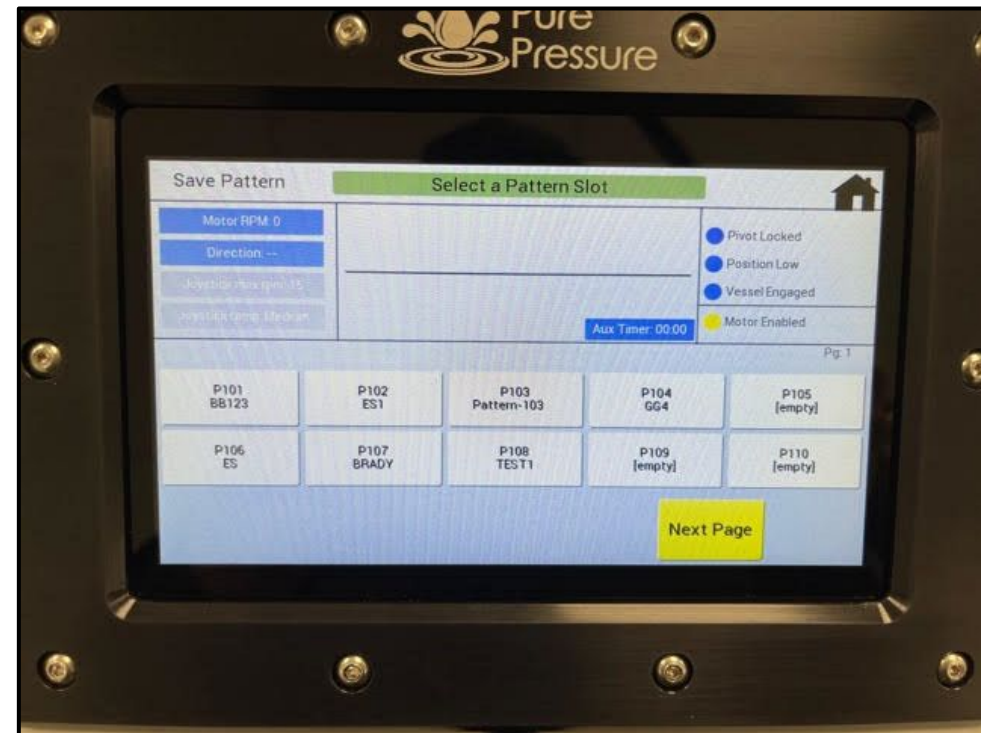

5.3 Table Patterns

45

Table Patterns allow the operator to create simple paddle motion by programming the paddle RPM, direction, and time. This includes a rest period, called a dwell, that may be programmed into the table pattern as well.

To program a table pattern, follow these steps:

1. Select an existing or blank pattern and press “Edit”.
2. You will see a table representing each distinct paddle motion in order. A blank table pattern will have one stage set to dwell for 0 seconds. Additional stages may be added by pressing the Stage # button. If you add more than 10 stages, you may press “Next” to view subsequent stages (up to 20 max).
3. To start building paddle motion, select the first block to highlight (blue). A series of choices will become available.
4. Select “Change RPM” and input a paddle RPM from 2-80. Typical patterns will range from 10 to 50 rpm.
 - a. **Note:** Operating above 50 rpm may damage your flower or break up the ice unnecessarily. This type of motion is generally not needed but in typical PurePressure fashion we give you full control.
5. Select “Toggle Direction” to change from paddle motion from clockwise (CW) to counterclockwise (CCW).

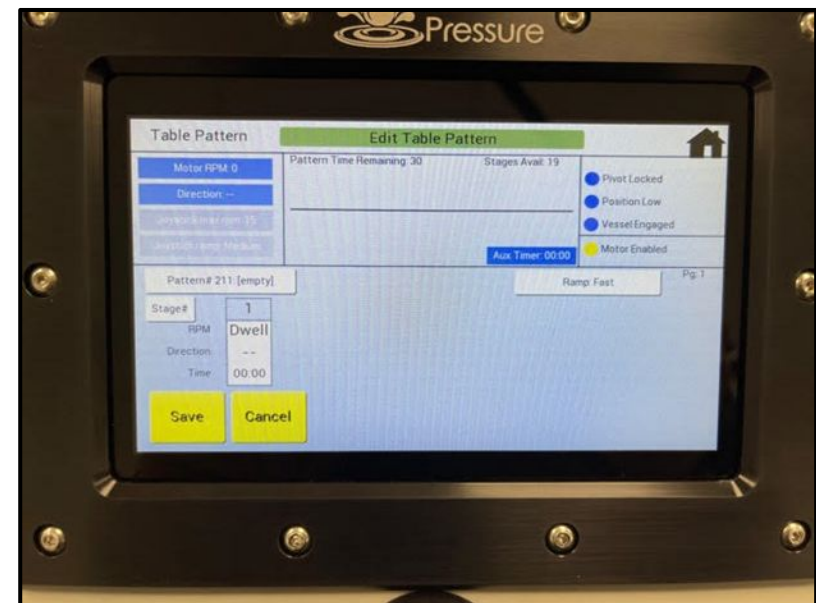
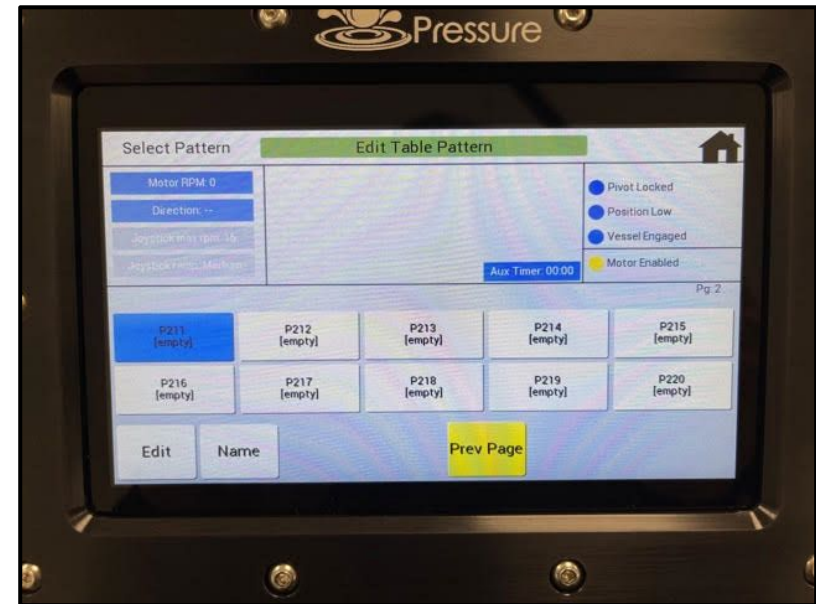

5.3.1 Table Patterns (continued)

46

To program a table pattern, continue to follow these steps:

6. Select “Change Time” to enter the paddle motion time.
Note: This is NOT an impeller mixer and the best results are often not found when the paddle is operated in one direction for extended periods of time. You will find that direction changes will induce the type of agitation that separates trichome heads.
7. If you wish to program a rest period, select “Dwell Pattern”.
8. Continue to program each stage of the table pattern.
Note: Patterns are intended to be repeated. Think about the motion in the final stage and how it will loop back into the first stage. You may find that you want to add/remove a stage to continue to alternate paddle direction as the pattern loops.
9. You will notice a graph is built to represent the motion of the pattern. A higher RPM will be seen with an increased amplitude on the Y-Axis, whereas time is represented on the X-Axis.
10. Press “Save” when complete.
11. You may then name the pattern. You may wish to include information such as Wash #, Vessel Size, Strain, or level of agitation.

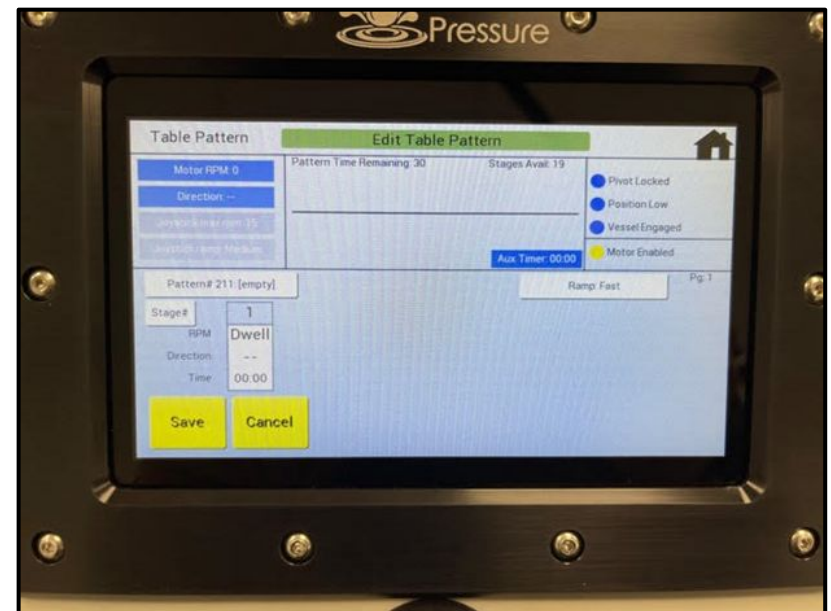
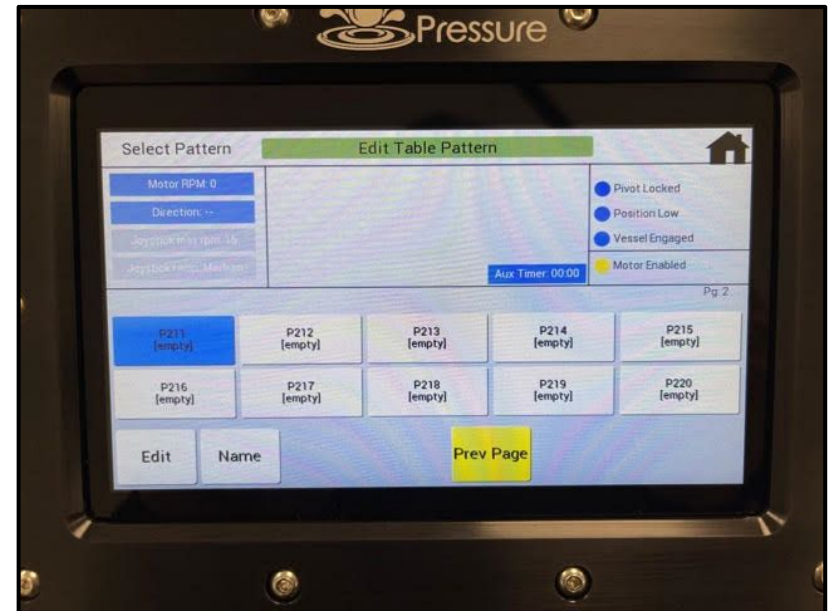

5.4 Quick Wash

47

Note: You will not be able to operate the Quick Wash feature without the motor enabled.

The Quick Wash feature allows the operator to load a vessel and start washing right away. Simply scroll through the list of available patterns.

Page indicators will identify the type of pattern (Joystick, Table, or Preset). You may press the page indicators to jump to a different section or you may use the Next/Prev Page buttons.

To utilize Quick Wash, follow these steps:

1. Ensure a vessel is loaded and the motor is enabled.
2. Select a pattern to immediately initiate paddle movement.
3. Select the same pattern again to dwell. You will notice the Recipe Elapsed time will continue to count.
4. Select a different pattern as you wish. You may change from pattern to pattern to create the perfect recipe.
5. The “Stages Available” count will start at 20 and reduce every time an action is taken (pattern selection or dwell). You may not exceed 20 stages.
6. When you are complete, press “Stop”. The resulting Quick Wash recipe will be displayed and may be saved as a recipe at this time by selecting “Save Last Wash”.

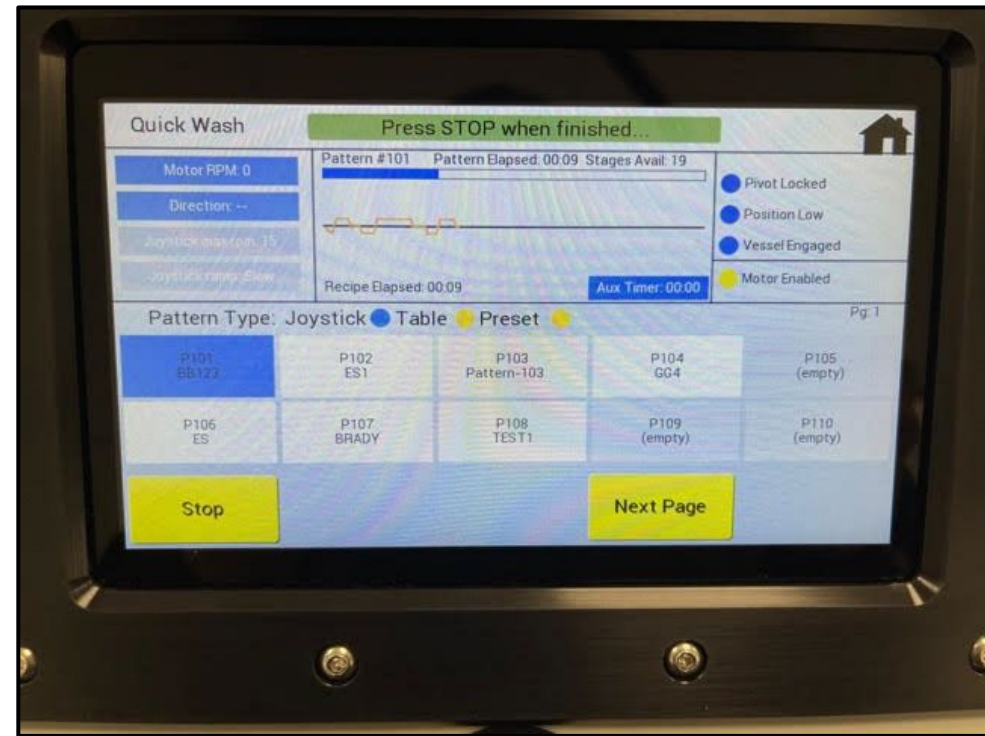

5.5 Recipes

Recipes is where you will find all of your saved recipes. A recipe consists of one or more patterns and may include a dwell (rest period). Recipes may be created manually or using Quick Wash and can be edited/customized as you wish.

Follow these steps to Edit a Recipe:

1. Select the Recipe you wish to modify and press “Edit”.
2. Similar to a table pattern, a recipe has stages. You may add stages by pressing the “Stage #” button.



3. Select a stage you wish to modify and you may change the pattern, pattern time, or dwell.
4. Press “Save” when your selections are complete.
5. Name the recipe; you may wish to include information such as wash #, vessel size, strain, level of agitation, etc.

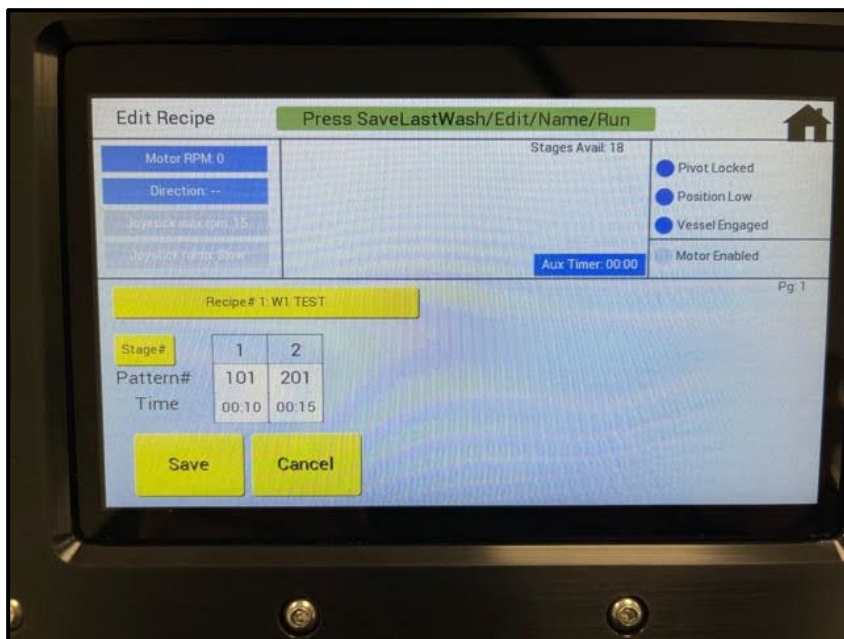

5.5.1 Recipes (continued)

49

Note: You will not be able to operate the Run Recipes feature without the motor enabled.

Running a Recipe

On the “Recipes” page, you are able to run any of your saved/created recipes, as well as the preset recipes that PurePressure provides

In order to successfully run a recipe, follow these steps:

1. Ensure a vessel is loaded and the motor is enabled.
2. With the desired recipe selected, press “Run”.
3. Press “Input Batch Information”. For your first wash, input all fields. For subsequent washes, you only need to track the vessel number. This will allow your team to easily track each batch and wash in the “History” section. This may be done after starting the recipe as well.
4. Press “Okay” and then press “Start” to begin the recipe.

The wash process will now begin and you will be able to track where you are in the recipe and even the pattern.

You may modify the recipe on the fly by pressing “Next Stage” or “Extend Stage” buttons.

If you wish to end the recipe early, you may press “Stop”.

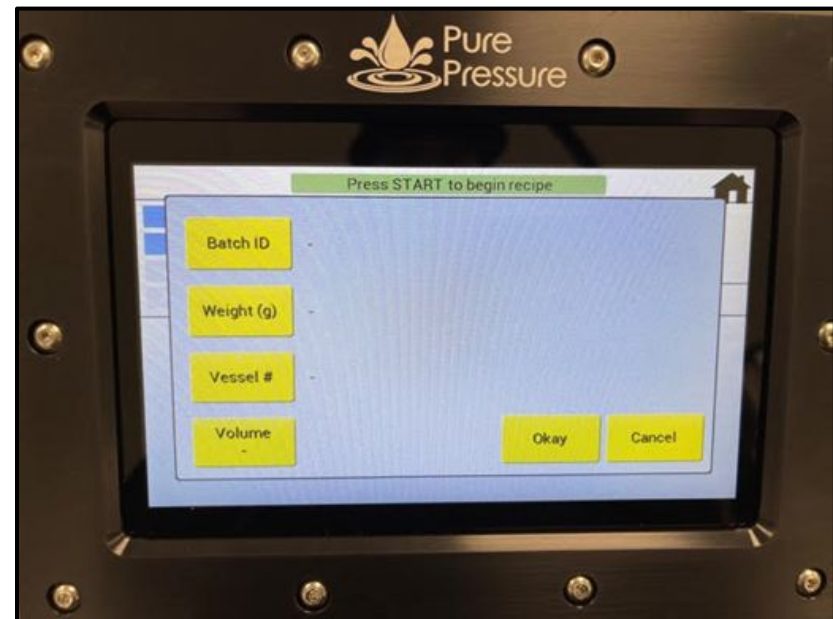
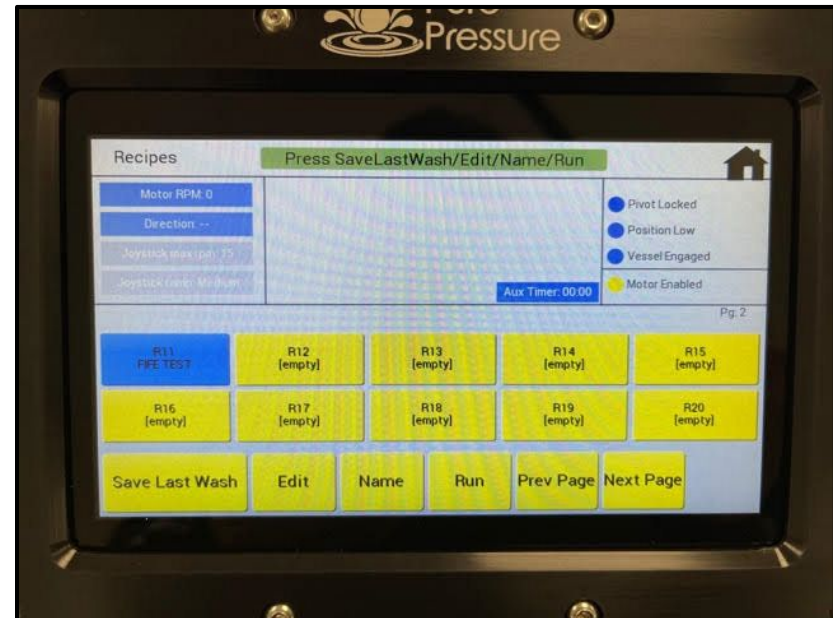

5.5.2 Recipes (continued)

50

Run Recipe Screen

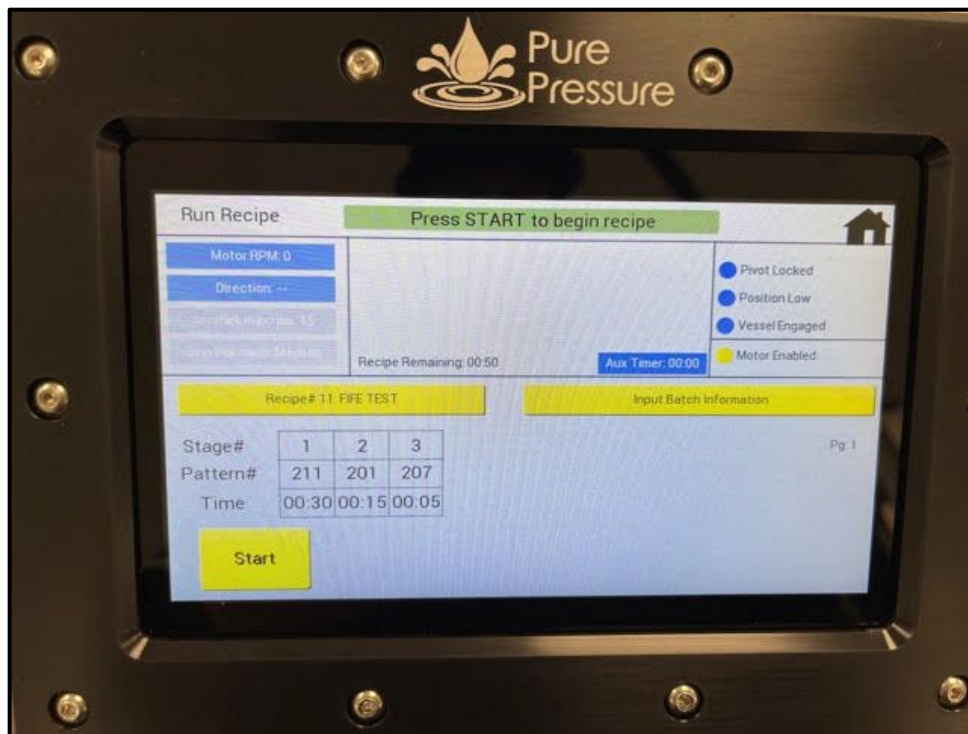

Playing Recipe Screen

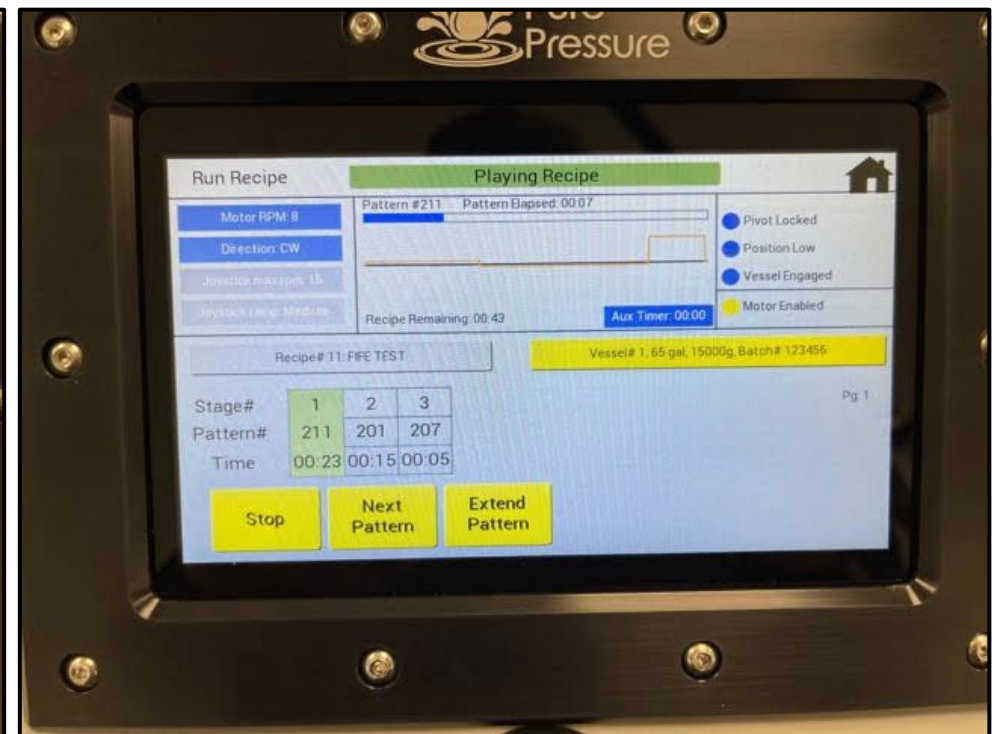

5.6 History

51

The History screen will give you valuable historical data on the recipes run. **As long as batch information is input consistently**, the user may easily track multiple vessels and manage seamless shift changes with ease.

There are many different ways to utilize the history and the statistical data the Axis displays. We have found the following best practices to maximize data output:

- Always input full batch information on the first wash of every batch.
- For subsequent washes, only enter the vessel number.
- This will allow you to track each batch easily and operators will be able to see which recipe should be run next.

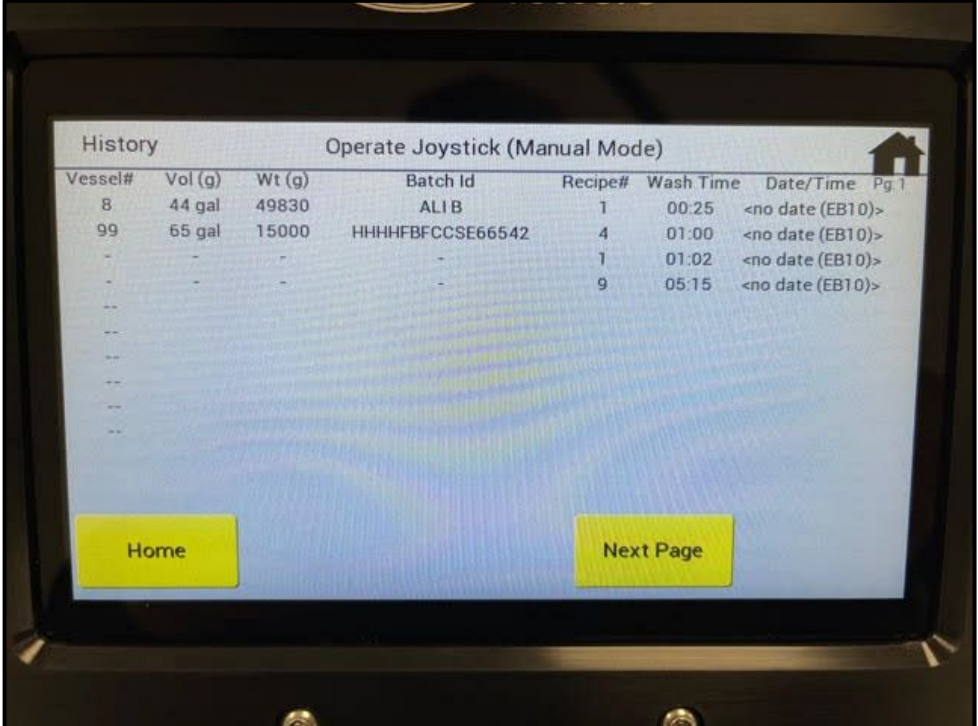

Vessel#	Vol (g)	Wt (g)	Batch Id	Recipe#	Wash Time	Date/Time	Pg. 1
8	44 gal	49830	ALIB	1	00:25	<no date (EB10)>	
99	65 gal	15000	HHHHFBFCCSE66542	4	01:00	<no date (EB10)>	
-	-	-	-	1	01:02	<no date (EB10)>	
-	-	-	-	9	05:15	<no date (EB10)>	

5.7 System Settings

You can adjust your system settings at any time. This will allow you to change a few key things to assist during the washing process. Below is a summary of the buttons available at the setting screen:

1: Buzzer

Turn the audible beeps on or off.

2: Statistics

View the system statistics and error messages.

3: Auxiliary Timer

Turn the Auxiliary timer on or off.

4: Set Date/Time

Program the date and time which is used in "History" and for maintenance reminders.

5: Recording

Disable recording to prevent accidental manipulation of patterns or recipes.

6: Maintenance Schedule

Manage and monitor maintenance schedule and reminders. When service is due, the buttons will change color to RED until the reminder is reset manually.

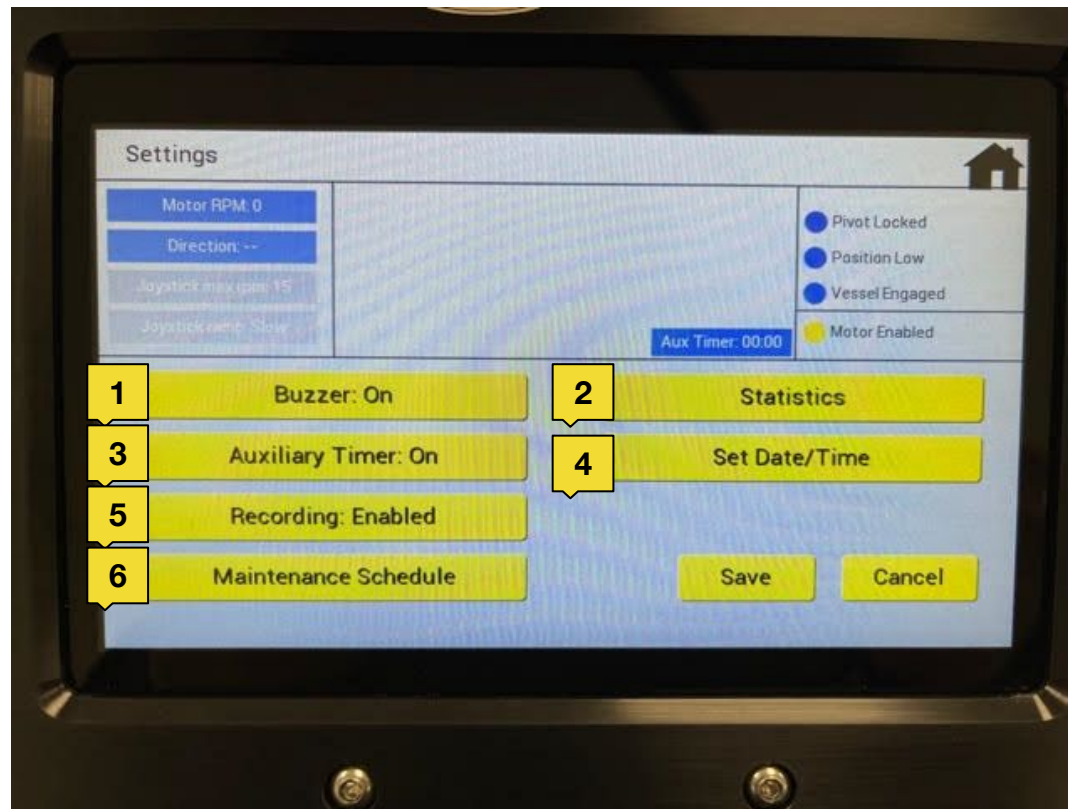

5.7.1 Maintenance Menu

53

You can adjust your maintenance menu settings at any time. We recommend maintaining a regular schedule. See the Service Manual for more details on maintenance. Below is a summary of the buttons available at the maintenance menu screen:

A: Belt Tension

The belt tension reminder is set from the factory to 120 hours. You may change the schedule to anything less than 120 hours.

B: Lubricate and Torque

The hinges and guard bolts need to be greased and various hardware checked for tightness. This schedule is set to 6 months or approximately 2,500 wash cycles, whichever comes first. You are NOT able to change this schedule.

C: Bearing / Drivetrain Service

The drivetrain of the Axis will need a major service after approximately 20,000 motor usage hours. You may change the schedule of service as needed.

D: Settings

This will return you back to the System settings screen.



5.8 Warnings & Errors

54

The touchscreen interface has a variety of error messages and warnings that may come about. These are features built-into the machine to recognize failure modes and operations. If an error occurs, there will be an error message that appears on the touchscreen, as well as a red light illuminated on the light tower.

Below is a summary of the three main warning messages that may occur with your touchscreen and what to do in the case an error occurs:

1. “E-stop engaged”
 - a. There are x2 E-stops, one on the Axis and one on the control stand.
 - b. Twist E-stop to release, the system will reboot and the motor will be disengaged.
2. “Material Too Dense”
 - a. The paddle has encountered significant resistance and the motor has detected that the requested paddle position doesn’t match the actual paddle position. Check for an obstruction and/or reduce the paddle RPM and ramp.
3. “Lifting head while moving”
 - a. If the relocating head of the Axis is lifted while the paddle is in motion, the interlocks will no longer be satisfied and this error will occur.
 - b. Ensure proper air pressure is supplied and the lever is in the down position.

6.1 Material Quality

Material Quality

- When processing ice water hash, high quality material goes a long way.
- It is important to select a strain/batch that has well developed trichome heads that are prone to separate under agitation.
- Strains that produce large, capitate-stalked trichomes are typically your best bet for isolating and capturing in the wash process.

Common Trichome Types

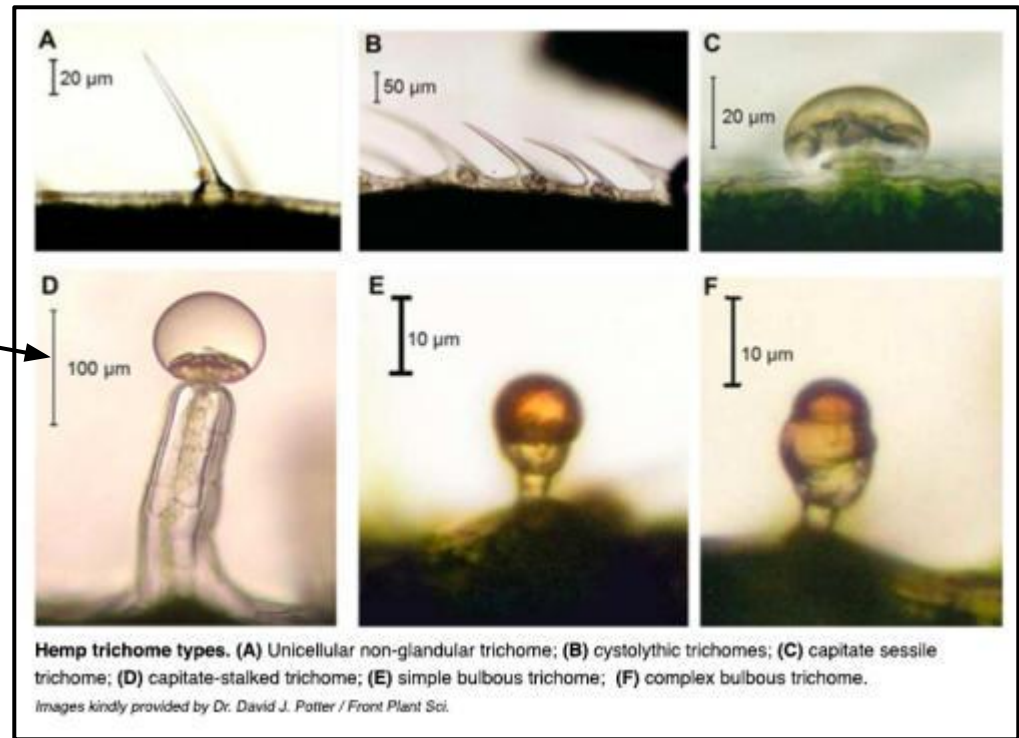

6.2 Intended Use

56

Intended Use

- The Axis trichome separator is intended to be used for the production of ice water hash utilizing a relocating head and interchangeable wash vessels.
- A filtration mesh wash bag lines the inside of the vessel. The vessels are to contain a mixture of water, ice and de-stemmed hemp/cannabis flower and trim.
- Ensure that there are no ice chunks larger than an apple as they could potentially get lodged between the paddle and the vessel, which in turn could damage the wash bag.



6.3 Single Vessel

57

Single Vessel Operation

- The Axis can be used in either single or multiple vessel operation.
- Single vessel operation is great for small batch or test washes.
- The relocating head may be raised and pivoted to gain access to the vessel while leaving the vessel in place.
- Alternatively, the vessel may be rolled over to a filtration station and brought back to the Axis for subsequent washes.

1 Vessel Setup

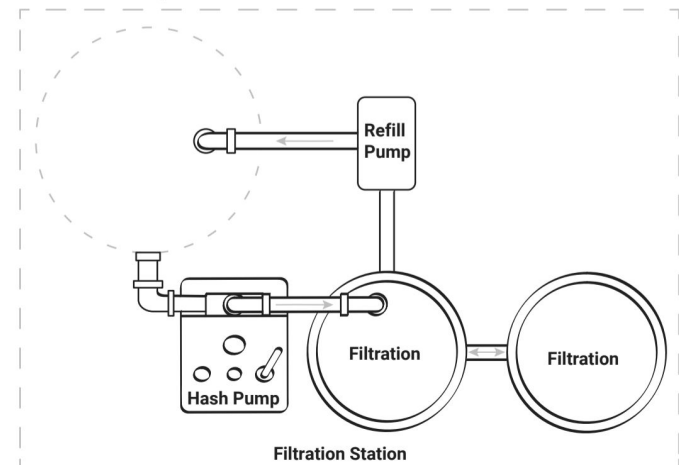
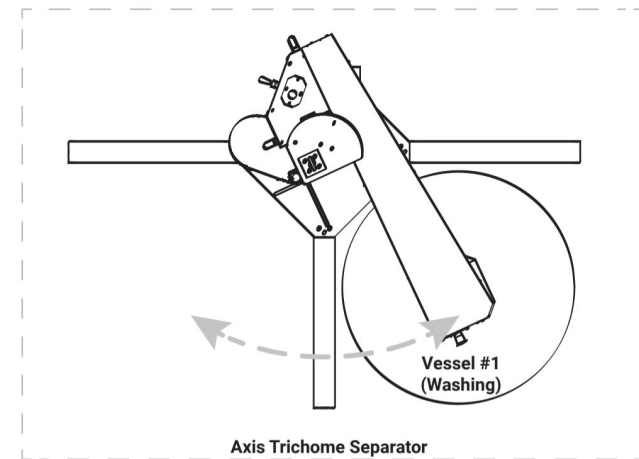

6.4 Multiple Vessels

Multiple Vessel Operation

- The Axis truly shines when the operator is able to take advantage of multiple vessel operation.
- The idea here is to maximize throughput by keeping the Axis paddle turning. The percentage of time the paddle is turning compared to the process time is called Machine Utilization Percentage.
- We want to maximize this percentage and the way to do that with a multiple vessel operation is be sure that you always have another vessel ready to be agitated.
- The number of vessels you need will be determined by your settling and filtration time.
 - If you can filter faster than you can wash, you may only need 2 vessels to keep the Axis busy.
 - If your filtration time takes significantly longer than your wash time, you may want to add additional wash vessels and filtration stations to balance the process and improve your throughput.

3 Vessel Setup

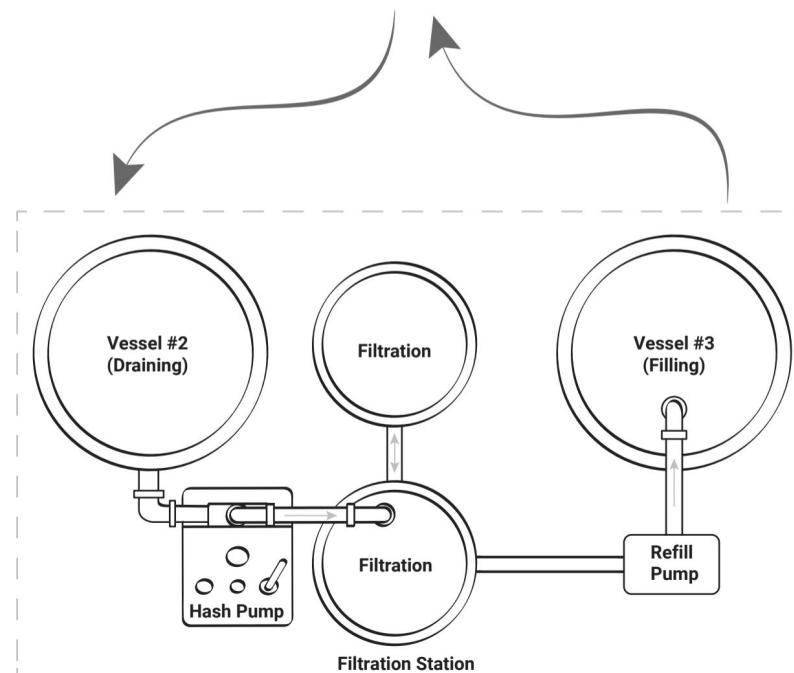
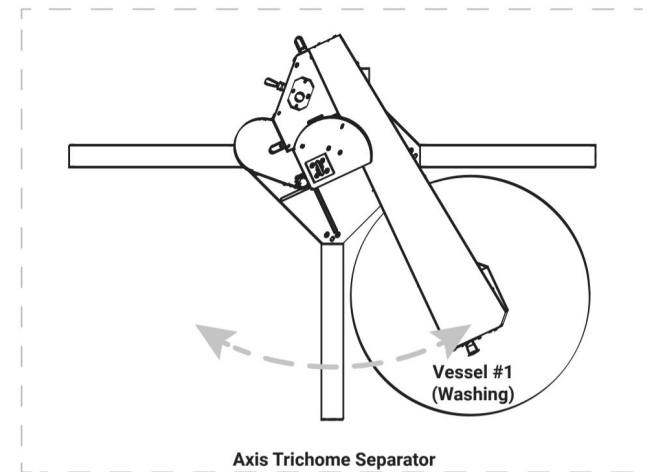

6.5 Filtration

59

Grading Your Hash and Making Product Decisions

After you've finished draining, collecting, and prepping your material for freeze drying (or air drying), then you can better determine what the strain you just washed is capable of, and where most of its trichome sizes ended up. Typically, for a full spectrum wash for general hash rosin and related SKUs, your 45, 73, 90, and 120 micron bags will collect the lion's share of your trichomes. For full melt and premium ice water hash SKUs, typically you will find your best results in the 120 micron to 73 micron range for most strains.

Generalized Micron Filter Guideline

220 μm	●	Work bag
190 μm	●	Clean up bag
160 μm	●	Food grade
120 μm	●	Excellent grade
90 μm	●	Excellent grade
73 μm	●	Excellent grade
45 μm	○	Secondary grade
25 μm	●	Food grade

Example of a Filled Full Spectrum Tray



7.1 Power Down

Power Down

- Always power down and unplug the machine before cleaning.
- The Axis is designed to meet the IP65 standard. We recommend using a wipe-only cleaning method as opposed to a hose down method to prevent standing water in undesirable locations.
- The Axis is NOT rated for a high powered pressure washer.



7.2 Vessel Guard Removal & Cleaning

61

Vessel Guard Removal & Cleaning

We recommend you do this before and after processing on a daily basis at minimum.

1. To remove the guard, first lower down onto a vessel. Ensure that no paddle is attached.
 2. A 3/8" nut driver is needed to remove the three bolts that hold the guard onto the relocating head.
 3. Raise the head, the guard should remain on the vessel.
 4. Guard components can be disassembled with a flat head screwdriver for cleaning and then reinstalled.
 5. A mixture of isopropyl alcohol and water can be used to clean the components with any build up or splash back from processing.
 6. Use a cotton rag for cleaning and to maintain optical clarity on your splash guard. **DO NOT USE ABRASIVE CLEANERS, BRILLO OR SCOURING PADS WHEN CLEANING, THIS WILL COMPROMISE THE OPTICAL CLARITY OF YOUR PETG GUARD.**
 7. The upper mating spring loaded component on the relocating head should get wiped down also before reassembly.
- **Deep Cleaning the Stainless Steel Components** - You can, however, use abrasives to clean Stainless Steel. To clean the S.S. component of you guard assembly we recommend Bar Keepers Friend. This product will clean and also passivate the S.S. which is a process that sanitizes and preserves the raw metal finish. We recommend this be done as needed. Follow Bar Keepers Friend instructions and rinse the component thoroughly with water, towel dry before reassembling.

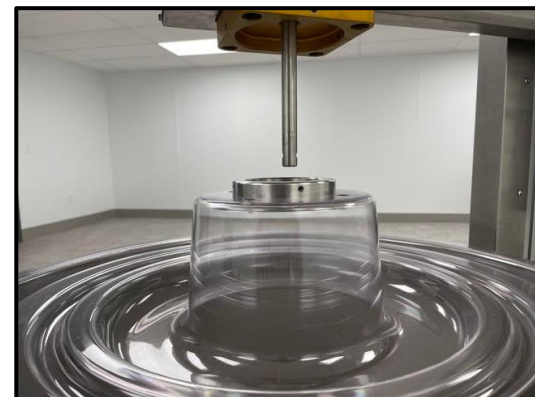
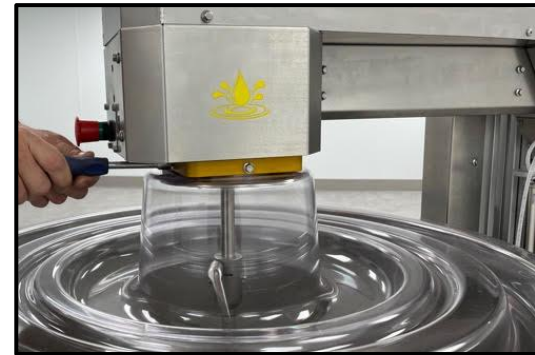

7.3 Cleaning the Axis

62

Cleaning the Axis

Exterior sheet metal and structural frame:

- We recommend you clean the machine every 40 hrs of operation at minimum to maintain a sanitary work environment.
- Cleaning more often may be required depending on material, level of machine use, and/or requirements of the facility/local regulators.
- To remove residue buildup from processing:
 - a. Power down and unplug the unit.
 - b. In a properly ventilated area, use a 70% isopropyl alcohol + 30% water mixture and wipe down the machine with a cotton rag.
 - c. Be sure to use a dry rag to remove all standing water visible on the machine once cleaned
 - d. Allow the machine to dry and then inspect enclosures for water before powering on the unit in a well ventilated room.
- To keep the exterior of machine looking sharp we recommend any food safe stainless steel cleaner or Bar Keepers Friend for deep cleaning as needed.
- When cleaning the sheet metal enclosure be sure not to scrub over the product labels or graphics with abrasive cleaners as it may compromise the integrity of those labels.



7.4 Control Stand Cleaning

63

Control Stand Cleaning

- Power down and unplug the unit.
- Keep the HMI screen clean. This should be wiped down daily.
 - **Note:** if hash or plant matter is stuck to the control screen, it will not operate correctly. Use the iso/water mixture and dry thoroughly.
- The rest of the control stand can be cleaned as often as needed.
 - Check and tighten electrical enclosure door screws to ensure a water tight fit is made before cleaning.
 - Be sure to check the touch screen enclosure door screws as well.
 - We recommend cleaning every 40 hours of operation minimum.
- Be sure to check inside the electrical box after washing down to make sure water has not migrated inside the box.
- When cleaning the enclosures be sure not to scrub over the product labels or graphics with abrasive cleaners as it may compromise the integrity of those labels.



7.5 Paddle & Coupler Cleaning

64

Paddle & Coupler Cleaning

- These components can be steam cleaned, washed in a commercial dishwasher or in an isopropyl alcohol and water mixture.
- Rinse thoroughly with tap water and dry off any standing water.
- DO NOT LEAVE STANDING WATER ON YOUR PADDLE AFTER CLEANING OR USE.
 - R.O. (reverse osmosis) water has a lower pH and has little or no alkalinity compared to tap water, so it is inherently more corrosive.
 - Stainless steel has been known to achieve surface rust with standing water left to sit on the surface. Micro particulates in the water can settle on the stainless steel surface and cause surface rust to occur. This would be a brown coloration, typically matching the shape of the water droplet left on the surface. This can be fixed and treated with Bar Keepers Friend.
- Treat your paddles with care and avoid dents or scratches on the coupler that can inhibit fitment with the shaft.
- **Deep Cleaning the Stainless Steel Components** - To deep clean the stainless steel components of the assembly we recommend Bar Keepers Friend. This product will clean and also passivate the S.S. which is a process that sanitizes and preserves the raw metal finish. We recommend this be done as needed. Follow Bar Keepers Friend instructions and rinse the component thoroughly with water, towel dry before assembling or letting sit.

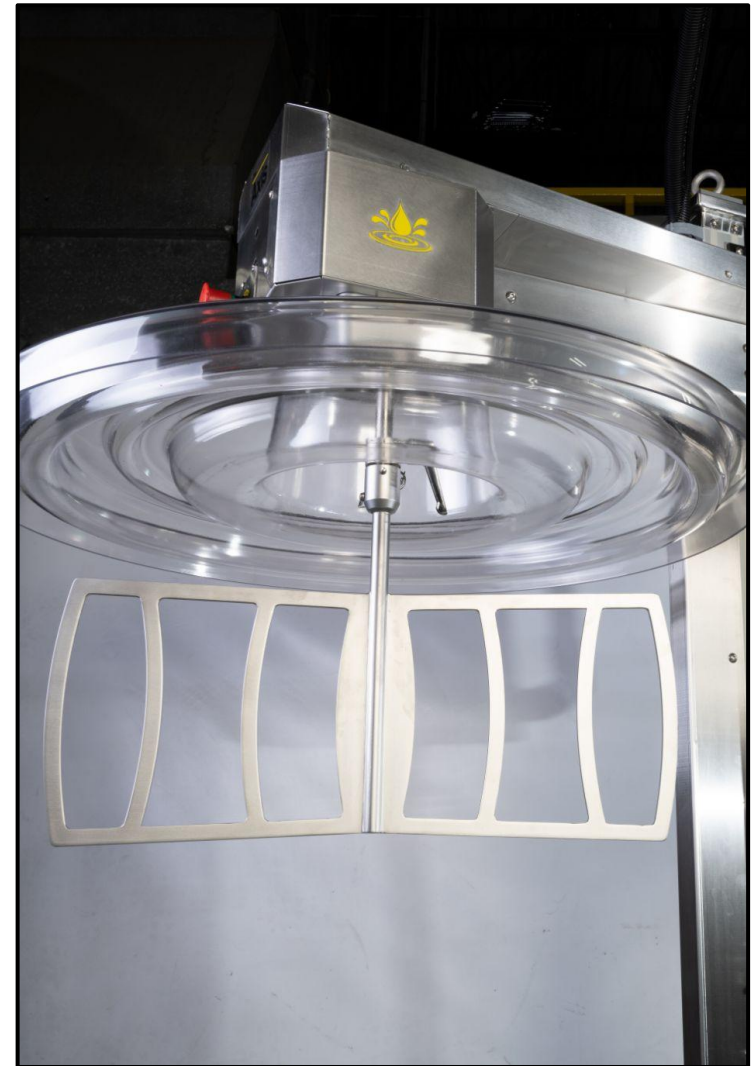

7.6 Vessel Cleaning

65

Care Instructions and Cleaning Advice

We strongly recommend deep cleaning your Bruteless stainless steel vessel, fittings, and paddle at the end of each day's washing. This will help ensure that your system stays contaminant free, which is crucial. RO water can be extremely corrosive; surface rust can appear even on stainless steel because of rogue particulate in standing water on the metal. We have two different cleaning recommendations depending on if you are cleaning your lines or the stainless steel surfaces of your system.

Lines, tubes, fittings cleaning: It is important to clean your equipment on a daily basis in order to keep your equipment operating at peak performance! Removable parts shall be removed and cleaned in a hot water commercial dishwasher or equivalent. The use of isopropyl alcohol mixture with water may be circulated in our equipment. Consult the label on the isopropyl alcohol container to achieve an appropriate concentration. Use a water rinse cycle after any alcohol cleaning cycle before placing the equipment back into service.

WARNING – alcohol is toxic – always work in a well ventilated area.

WARNING – alcohol is flammable – extreme care shall be taken during the use of this solvent.

Stainless steel surface cleaning: Use tap water with Bar Keepers Friend. We recommend using Bar Keepers Friend brand cleaning powder because it passivates your stainless and prevents rust. Use a gentle abrasive pad such as the Scotch-Brite 7445 Light Duty Cleansing Pads. Dry the surfaces well & do not leave standing water on the metal to dry off.

Never Use These Products

Bleach, Comet, or any other non food safe cleaning product or solution.

Neoprene Insulation Sleeve Care

The insulation jacket is composed of a shell and a core. The shell is neoprene and can be wiped clean if needed. The core is a moisture resistant closed cell foam and should not absorb liquid.

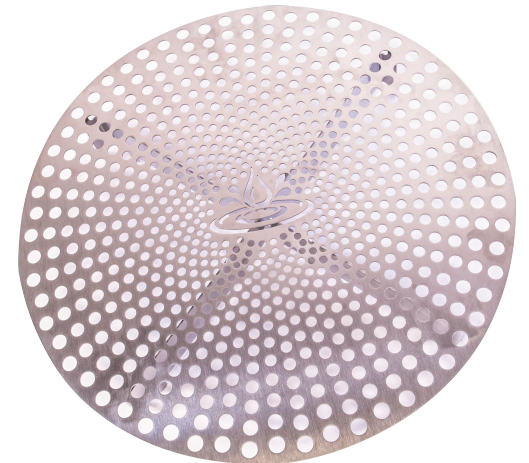

8. Maintenance & Troubleshooting

66

Maintenance Overview

Your Axis trichome separator is engineered to operate for an extremely long time if its basic maintenance needs are met. Please refer to the Axis service manual for more information or contact us at 720-446-9565 or support@gopurepressure.com if you need help.

Belt Tension

Belt tension should be checked every 120 hours of motor operation. Use the PurePressure optical tension meter to quickly measure frequency of the belt. See service manual for details on this process.

Lubricate and Torque

Some components need periodic lubrication and tightening to maintain peak performance. The hinges, guard springs, guard bolts, linear rails, gas spring and pneumatic cylinders have specific lubrication requirements. See the service Manual for details on this process.

Bearing / Drivetrain Service

Service is anticipated after approximately 20,000 motor usage hours. See the service manual for details.

8.1 Common Issues

67

Problem: Interlock will not engage (no blue light).

Solution: Inspect the touch screen interface to determine which interlocks are not engaged.

Pivot Locked - Ensure the head is locked into position

Position Low - Verify that the vessel is properly engaged, and the toggle lever is in the down position. Check leveling feet as they may be too high.

Vessel Engaged - Verify that the vessel is properly engaged, and the toggle lever is in the down position. Check leveling feet as they may be too high.

Problem: Vessel does not fit in the guard.

Solution: Sometimes the insulating jacket can become bunched up near the top of the vessel. If this happens, there may not be enough room for the guard to fully engage. Inspect the neoprene and smooth out any lumpy areas. You may push the insulation jacked down to create a small gap between the insulation and the vessel lip. Once the jacket has been worked smooth, the guard should engage properly. You may also trim the foam insulation under the neoprene to customize the fitment as you wish.

Problem: Motor will not enable.

Solution: All interlocks must be satisfied, and the blue light must be illuminated. If the blue light is illuminated and you cannot enable the motor, one of your interlock switches is barely engaged. There are two circuits internal to the switch and both must be made for the motor to enable. Check that each interlock is fully engaged as described previously.

Problem: Head will not go down.

Solution: Ensure the vertical spring plunger is held in the release position before flipping the toggle lever to the down position. Check for proper air pressure. Inspect the pressure regulator and gauge inside the head enclosure. You should need 75-90 psi to lower the head and properly engage the guard interlock. Check that the speed controller on the pneumatic cylinder isn't closed too far. The upper fitting controls the downward speed. The paddle size is too large for the vessel and is crashing. Insert the proper paddle size. An obstruction is blocking movement within the carriage assembly and the linear rail. Check for any obstructions and contact PurePressure for a solution.

8.1.1 Common Issues (continued)

68

Problem: Relocating Head will not go up.

Solution: Check for proper air pressure. Inspect the pressure regulator on the back of the control stand. You should need 100-120 psi to properly raise the head with a paddle attached. Check that the speed controller on the pneumatic cylinder is not closed too far. The lower fitting controls the upward speed. An obstruction is blocking movement within the carriage assembly and the linear rail. Check for any obstructions and contact PurePressure for a solution.

Problem: Pivot does not engage or will not pivot.

Solution: Ensure the spring plunger moves freely and can fall into the pinholes. Check for an obstruction within the hinging members. Properly grease the hinges. Use a step stool to inspect the alignment of the plunger with the pin holes. Adjust the polyurethane bumpers if they are preventing pin engagement. Contact PurePressure if you have alignment issues.

Problem: Belt noise (skipping).

Solution: Improper belt tension can lead to belt skipping, typically during direction changes. Tension the belt to 28-29 Hz, follow the directions in the service manual to properly tension the belt. Every 1 Hz the belt is tensioned over 29 Hz will decrease the bearing life by 1 year if the belt is operated continuously at that tension!

Problem: Drivetrain noise (grinding).

Solution: Remove the pulley cover and inspect the pulleys for drift on the shaft. They should be flush with the top of the shaft as pictured below. Ensure the spring-loaded guard interlock can fully engage. If a small gap is left between the two aluminum plates a vibration can occur that sounds like a metal-on-metal grinding. The compression force from the pneumatic cylinder will eliminate this noise once the machine is lowered slightly with the leveling feet, allowing this compression force to be applied. Paddle Resonance – The shape and construction of the paddle lends it to be very similar to a tuning fork. When ice impacts the paddle blade, you may hear a resonating vibration. This does not cause any harm to the machine and once you are aware of the sound, you may be able to distinguish and understand the noise.

Problem: Vertical play in motor or paddle drive shafts.

Solution: Disconnect power from the axis. Remove the pulley cover and remove the belt. Grab each pulley and push/pull to check for axial movement. If you have more than 1/32" of movement, then the shaft collars need to be adjusted and tightened.

8.1.2 Common Issues (continued)

69

Problem: Bearing failure (squeak, squeal, grind).

Solution: Eventually the bearings are going to need to be replaced. Paying careful attention to the sounds your machine makes can help diagnose a bearing failure before it happens. Listen for squeaks, squeals, and grinding noises that follow the motion of the paddle. You may hear tonal changes in the noise as you change direction and rpm. We anticipate the first bearing change to be required around 20,000 hours of use. See the Service Manual for instructions.

9.2 Frequently Asked Questions

70

What Pressure Should I Use?

Air pressure controls the vertical travel of the machine. The Axis will come factory set to **120psi**. All of that air pressure is used to raise the relocating head. There is an internal regulator for the downward travel and that pressure is factory set at **90psi**.

I Have a Leak, What Should I Do?

Identify where the leak is coming from. Leaks can happen for all sorts of reasons. Dry the water with a rag so you can find where it is coming from. Once the origin of a leak is identified, you can react according to the problem. Some common reasons a leak may occur include: damaged hose, damaged to the welded port on the vessel, incorrect tri clamp install (damaged or missing gasket), and incorrect hose barb install. The most common reason for a leak is incorrect installation. Start with checking all of these suggested failure points.

Do I Need to Use a Wash Bag?

The short answer is no, PurePressure recommends that you do use a wash liner. Using a wash liner will inevitably avoid port clogging and post filtration labor. That being said, we have absolutely had customers wash without a liner in our vessels and had success with doing so. It all depends on the operator's post-filtration method.

Can I wash Hemp with My Axis?

The quick answer here is YES! The Axis can be used with all types of material, HOWEVER, the micron size of the filtration bags have to be strategically paired with the material being washed. This is all up to the operator and filtration methods.

Why are My Wash Liners Getting Damaged?

The wash liners are designed and made by PurePressure to avoid contact with the paddle by the use of dowel rods that hold the liner open inside the vessel. In the past, we have seen damage to liners due to hand paddling and the collision of the paddle causing holes and tears in the liner. The liner if used properly, should not interfere with the properly sized Axis paddle blade.

You can always contact PurePressure for support on how to proceed if help is needed with the operation of our equipment!



 720-446-9565

 purepressure.com

Sales Inquiries:

sales@gopurepressure.com

General Questions:

info@gopurepressure.com

Technical Support:

support@gopurepressure.com

   @gopurepressure

— **We're always here to help.**

Axis User Manual
R1.1