

TOOLS NEEDED

- 8MM ALLEN WRENCH
- NM TORQUE WRENCH
- ALL-PURPOSE BICYCLE GREASE
- TOOLS REQUIRED TO REMOVE YOUR OLD PEDALS, IF APPLICABLE
(CHECK WITH MANUFACTURER)

WARNING: DO NOT DRILL INTO OR MODIFY THE LOAM PEDAL IN ANY WAY. DOING SO WILL VOID THE WARRANTY. MODIFICATION OF THE LOAM PEDAL IN ANY WAY MAY RESULT IN PEDAL FAILURE WHICH MAY RESULT IN SERIOUS INJURY OR DEATH.

PACKAGE INCLUDES

- (2) LOAM PEDALS
- (2) PEDAL WASHERS

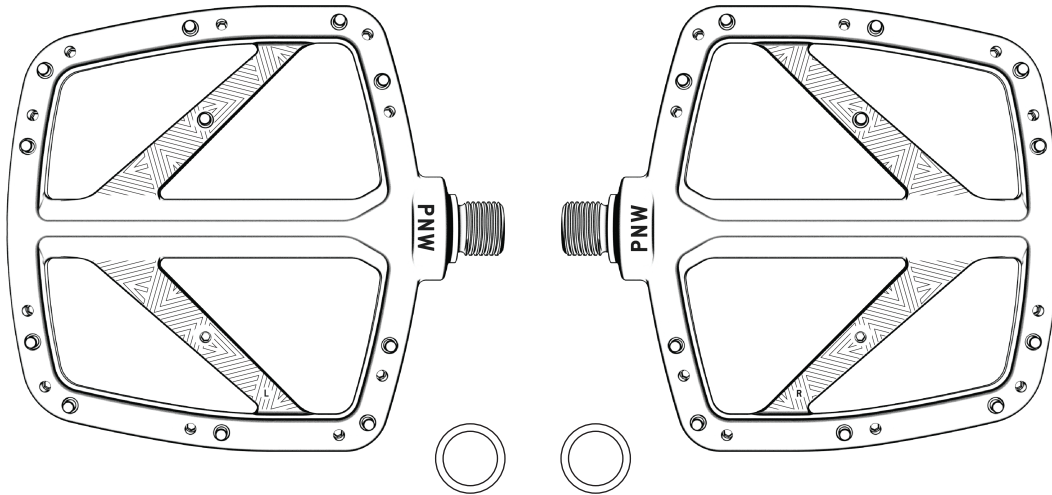
**LOAM PEDAL INSTALL****STEP 1**

SLIDE A PEDAL WASHER ONTO THE AXLE OF EACH PEDAL.

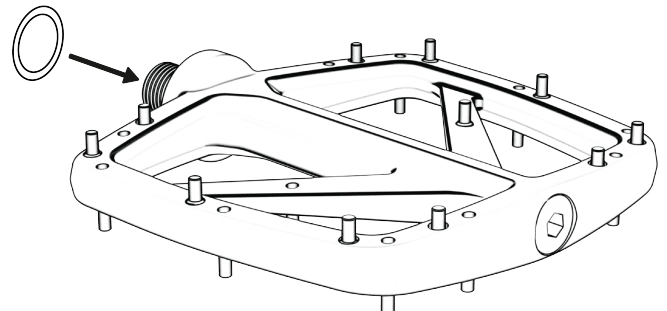
**CONT'D...**

STEP 2

GREASE THE THREADS OF THE AXLE OF EACH PEDAL.

STEP 3

THE LOAM PEDALS ARE SPECIFIC TO THE RIGHT (DRIVESIDE) AND LEFT (NON-DRIVESIDE) OF THE BIKE. TO DETERMINE WHICH PEDAL IS WHICH, LOCATE THE "R" OR "L" ON EACH PEDAL BY FINDING THE CORRESPONDING "R" AND "L" LASER ETCHED INTO THE CROSSBAR OF THE PEDAL PLATFORM.

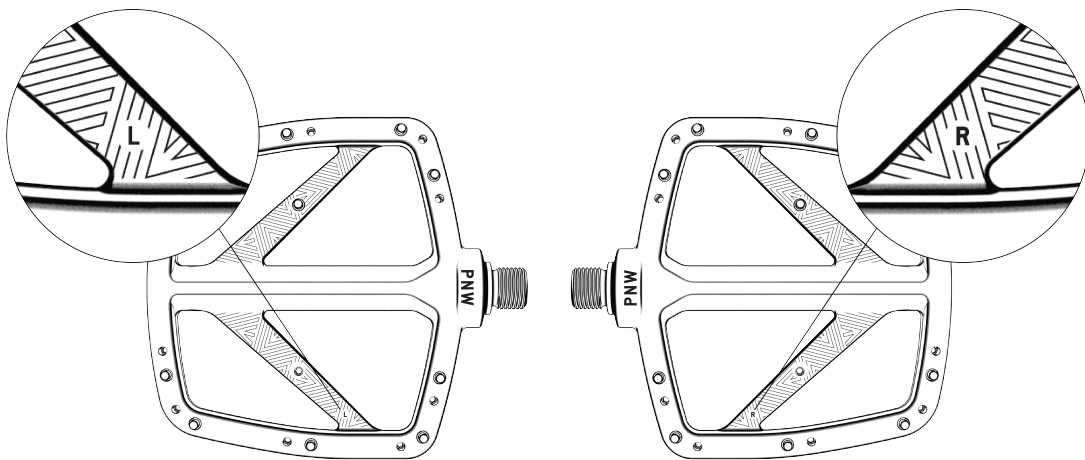

STEP 4

TO INSTALL THE RIGHT (R) PEDAL, START BY THREADING THE PEDAL AXLE CLOCKWISE (TURNING TO THE RIGHT) INTO THE DRIVESIDE CRANK ARM. NEXT, INSERT YOUR 8MM ALLEN WRENCH THROUGH THE BACKSIDE OF THE DRIVESIDE CRANK ARM AND CONTINUE TURNING THE AXLE CLOCKWISE UNTIL THE PEDAL AXLE IS FULLY SEATED IN THE CRANK ARM. LASTLY, USING YOUR TORQUE WRENCH, TIGHTEN THE AXLE TO 35NM.

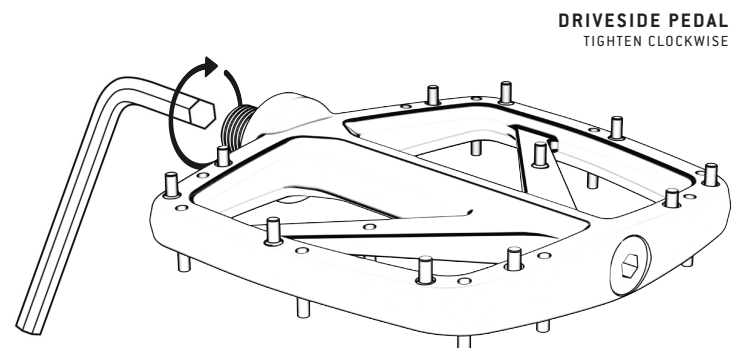

CONT'D...

NON-DRIVESIDE PEDAL
TIGHTEN COUNTERCLOCKWISE

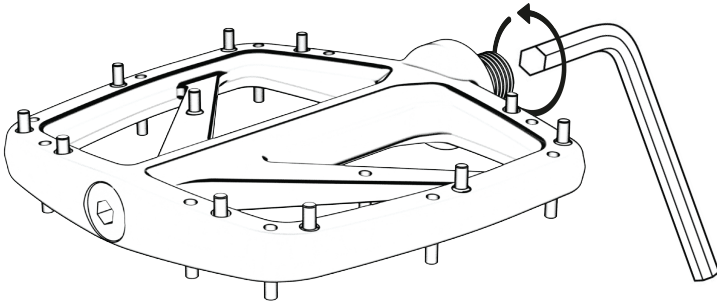

STEP 5

TO INSTALL THE LEFT (L) PEDAL, START BY THREADING THE PEDAL AXLE COUNTERCLOCKWISE (TURNING TO THE LEFT) INTO THE NON-DRIVESIDE CRANK ARM. NEXT, INSERT YOUR 8MM ALLEN WRENCH THROUGH THE BACKSIDE OF THE NON-DRIVESIDE CRANK ARM AND CONTINUE TURNING THE AXLE COUNTERCLOCKWISE UNTIL THE PEDAL AXLE IS FULLY SEATED IN THE CRANK ARM. LASTLY, USING YOUR TORQUE WRENCH, TIGHTEN THE AXLE TO 35 NM.