

TOOLS NEEDED

- 2MM, 3MM, AND 5MM ALLEN WRENCHES
- CABLE CUTTERS
- HIGH PRESSURE SHOCK PUMP

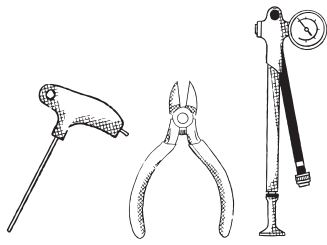

WARNING: DO NOT DRILL OR MODIFY YOUR FRAME IN ANY WAY. DOING SO WILL VOID THE WARRANTY. MODIFICATION OF YOUR FRAME IN ANY WAY MAY RESULT IN FRAME FAILURE WHICH MAY RESULT IN SERIOUS INJURY OR DEATH.

PACKAGE INCLUDES

- DROPPER POST
- PUGET 2X LEVER WITH HINGED CLAMP
- CABLE NOODLE WITH ROTARY FERRULE
- LEVER BOLT
- SHIFTER CABLE
- CABLE HOUSING
- CRIMPABLE CABLE END
- HOUSING ENDS
- SHIFTER CABLE END BARREL ADAPTER.

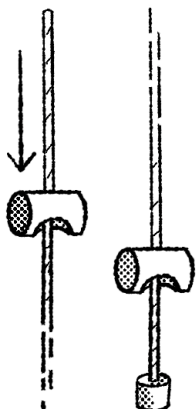
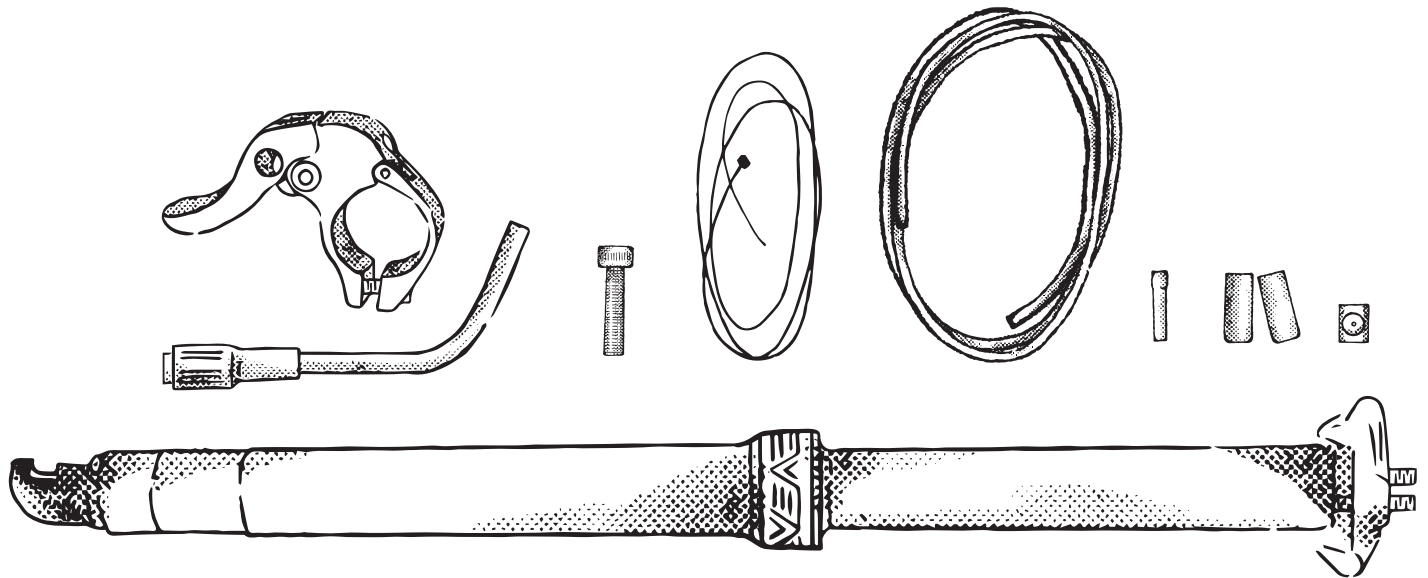

STEP 1

INSERT CABLE INTO SHIFTER CABLE END BARREL ADAPTER.

CONT'D...

STEP 2

INSERT CABLE WITH BARREL ADAPTER INTO DROPPER POST ACTUATOR ROD.

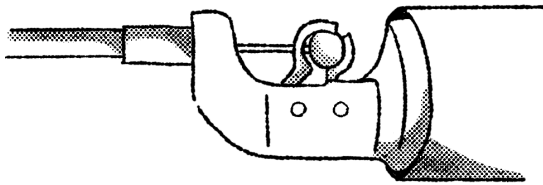
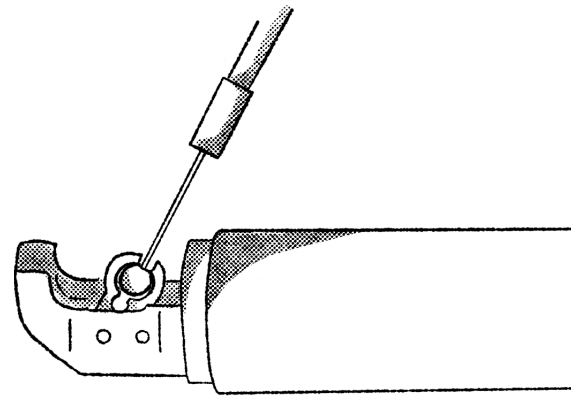

STEP 3

PULL ACTUATOR ROD AND INSERT CABLE THROUGH SLOT. SET CABLE HOUSING INTO THE BOTTOM HOUSING HOLDER.

STEP 4

INTERNALLY ROUTE CABLE HOUSING THROUGH FRAME ACCORDING TO MANUFACTURER'S RECOMMENDATIONS.

NOTE: MAKE SURE TO RE-INSTALL THE CABLE FERRULES ONTO THE ENDS OF THE CABLE HOUSING BEFORE INSTALLING INTO THE POST OR LEVER. THE CABLE FERRULES CAN BE PULLED OFF THE EXISTING HOUSING, THEY AREN'T PERMANENTLY ATTACHED

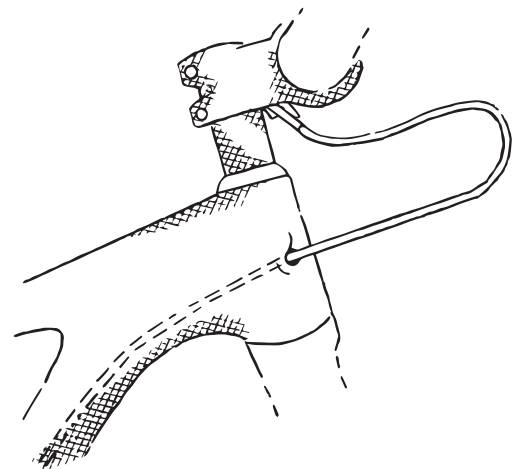

CONT'D...

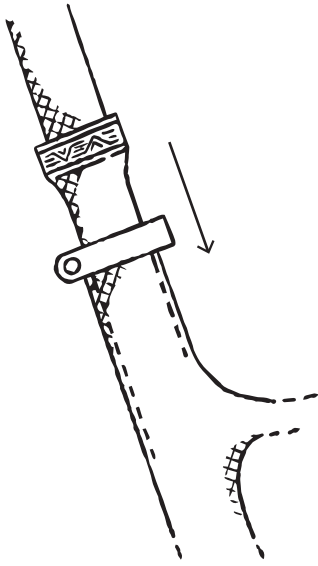

STEP 5

INSERT THE DROPPER POST INTO PROPERLY LUBRICATED SEAT TUBE. BE SURE TO INSERT POST BEYOND MINIMUM INSERTION LINE ON POST.

STEP 6

TIGHTEN SEAT TUBE CLAMP TO THE RECOMMENDED TORQUE SPECIFICATIONS OF YOUR MANUFACTURER.

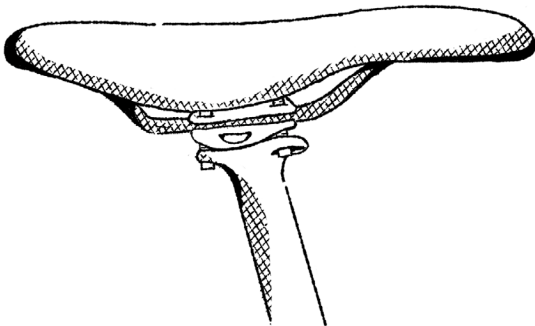
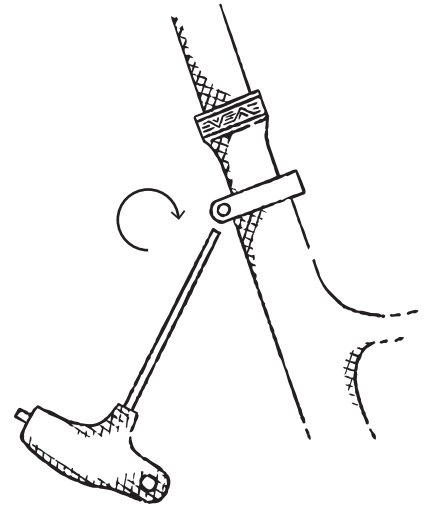

STEP 7

PLACE SADDLE RAILS INTO CLAMP, ADJUST ANGLE AND FORE/AFT POSITION PER BIKE FIT, TIGHTEN BOLTS WITH 5MM ALLEN WRENCH TO 8-10NM.

PUGET 2X LEVER INSTALL

STEP 1

POSITION HINGED LEVER CLAMP ON BAR TO NOT INTERFERE WITH FRONT SHIFTER AND TIGHTEN WITH 3MM ALLEN WRENCH TO MAXIMUM 2NM.

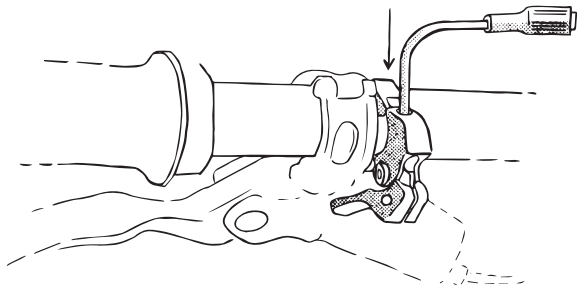
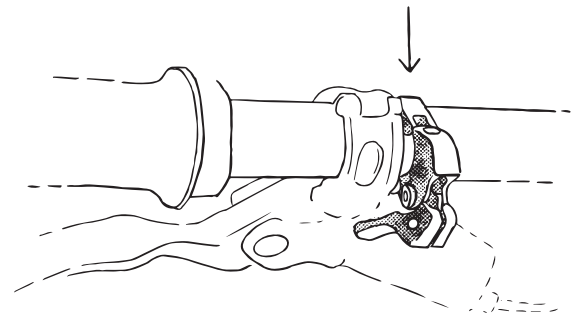

STEP 2

INSERT END OF CABLE NOODLE WITH ROTARY FERRULE INTO LEVER UNTIL THE CABLE NOODLE IS COMPLETELY SEATED.

STEP 3

INSERT CABLE ORIGINATING AT DROPPER POST THROUGH ROTARY FERRULE AND THROUGH THE HOUSING TO THE LEVER.

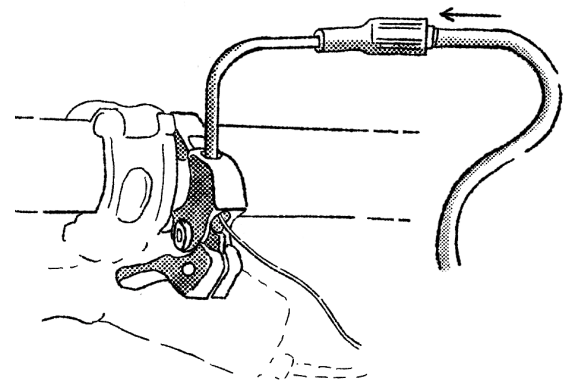

CONT'D...

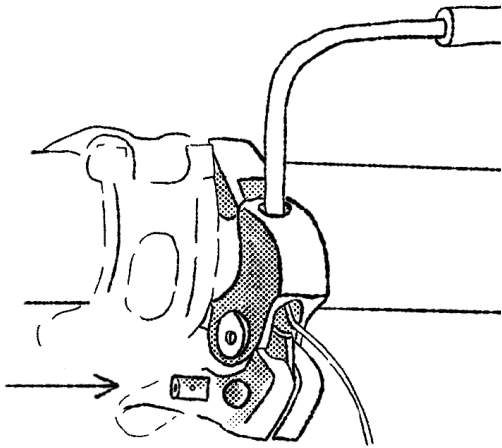

STEP 4

INSERT BARREL NUT INTO THE ROUND FLOATING CENTER BLADE OF THE LEVER. IT IS CRUCIAL THAT THE BARREL NUT IS PLACED INTO THE CURVED PORTION OF THE FLOATING CENTER BLADE. NOTE: THE BARREL NUT THAT WILL BE INSERTED INTO THE LEVER HAS A HOLE FOR THE CABLE TO SLIDE THROUGH AND IS TIGHTENED USING A 2MM AND 3MM ALLEN WRENCH.

STEP 5

PULL THE CABLE THROUGH THE LEVER AND HOLE IN THE BARREL NUT UNTIL THE CABLE IS TIGHT.

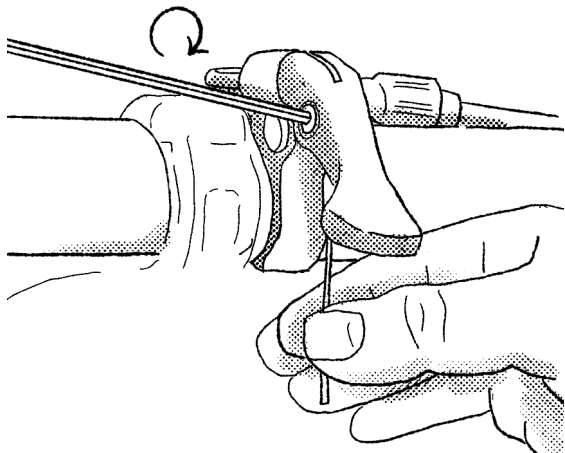
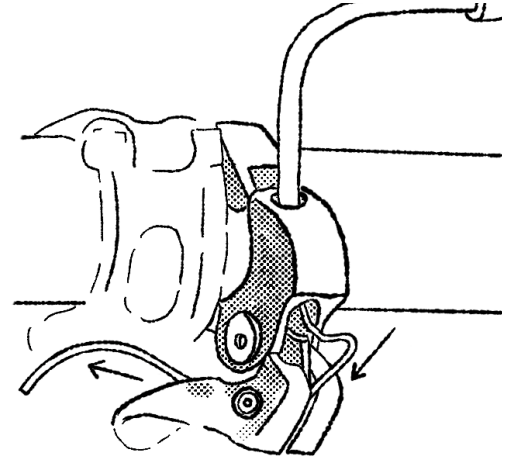

STEP 6

TIGHTEN THE BARREL NUT WITH A 2MM ALLEN WRENCH ON ONE SIDE AND A 3MM ALLEN WRENCH ON THE OTHER SIDE. NOTE: YOU MAY HAVE TO BACK OFF THE 2MM SIDE TO OPEN THE HOLE IN THE BARREL NUT.

STEP 7

PUSH THE LEVER 5-10 TIMES TO MAKE SURE THE CABLE HOUSING IS FULLY SEATED AND TO CHECK FOR PLAY IN THE CABLE. NOTE: IF THERE IS PLAY IN THE LEVER/CABLE, LOOSEN BARREL NUT WITH 2MM AND 3MM ALLEN WRENCHES AND PULL CABLE TIGHT A SECOND TIME. FOR MICRO ADJUSTMENT, USE THE ROTARY FERRULE ON THE CABLE HOUSING.

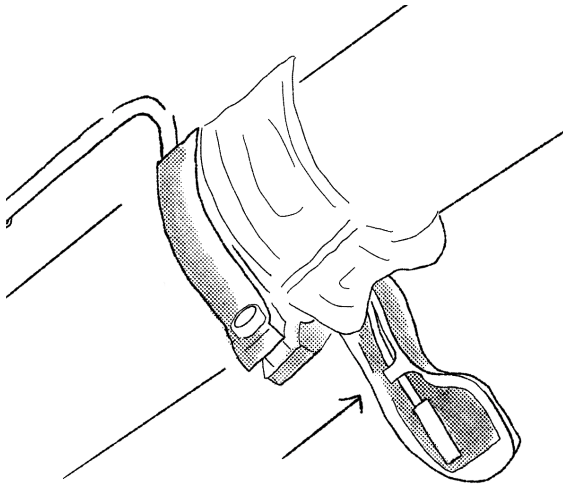
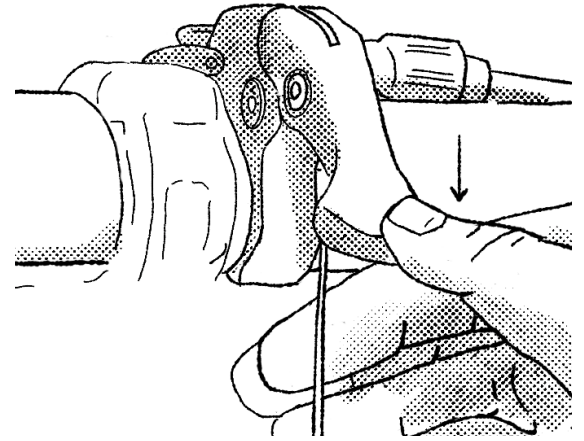

STEP 8

SLIDE CABLE INTO THE GUIDE UNDER THE LEVER. TRIM EXCESS CABLE WITH CABLE CUTTERS WITH ENOUGH ROOM TO PLACE CABLE END, APPROXIMATELY 10MM. IT IS IMPORTANT TO USE PROPER CABLE CUTTERS TO PREVENT THE CABLE FROM FRAYING.

STEP 9

CRIMP CABLE END IN PLACE.
PUSH LEVER.
DROP POST.
GET RAD.

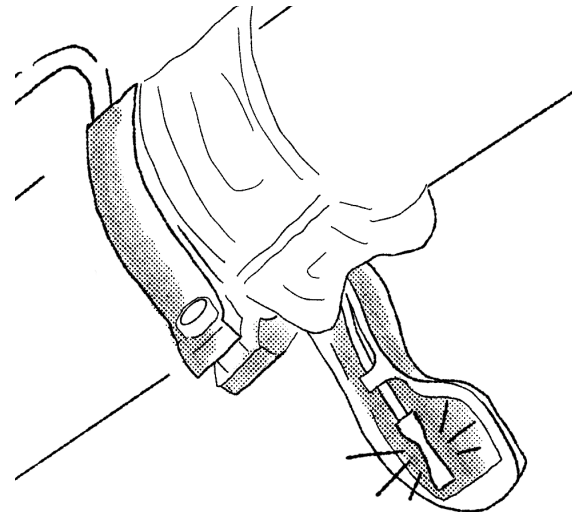

CONT'D...

ADJUSTING REBOUND RATE

THE LOAM DROPPER POST FEATURES AN ADJUSTABLE AIR SPRING CARTRIDGE. TO ADJUST HOW QUICKLY THE SEAT POST RETURNS YOU CAN CHANGE THE AIR PRESSURE OF THE MAIN CHAMBER OF THE POST. NOTE: YOU WILL NEED A HIGH PRESSURE SHOCK PUMP.

STEP 1

REMOVE ONE BOLT OF SEAT CLAMP AND REMOVE SEAT FROM POST.

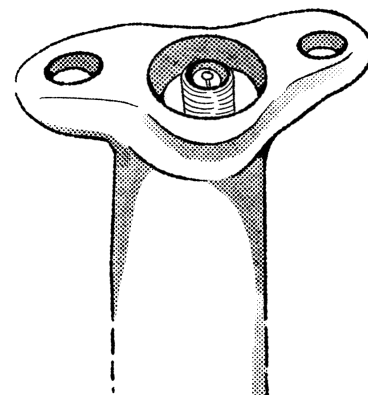

STEP 2

REMOVE RUBBER PLUG TO REVEAL VALVE. USE A COMPATIBLE SHOCK PUMP TO SET PRESSURE BETWEEN 230-300PSI.

WARNING: DO NOT EXCEED 300PSI.

