

ISONAS™

PURE IP ACCESS CONTROL



How to Install an ISONAS PowerNet™ Reader-Controller

*Copyright © 2006-2014, ISONAS, Inc.
All rights reserved*

ISONAS Inc.

FCC ID: OCZRC-03, OCZRC-03M, OCZRC-03ALLE
IC: 8431A-RC03, 8431A-RC03M, 8431A-RC-03ALLE

This device complies with **Part 15 of the FCC Rules**.

Operation is subject to the following two conditions:

- (1) This device may not cause harmful interference, and
- (2) This device must accept any interference received, including interference that may cause undesired operation.

Changes or modifications not expressly approved by the party responsible for compliance could void the user's authority to operate the equipment.

This equipment has been tested and found to comply with the limits for a Class B digital device, pursuant to part 15 of the FCC Rules. These limits are designed to provide reasonable protection against harmful interference in a residential installation. This equipment generates, uses, and can radiate radio frequency energy and, if not installed and used in accordance with the instructions, may cause harmful interference to radio communications. However, there is no guarantee that interference will not occur in a particular installation. If this equipment does cause harmful interference to radio or television reception, which can be determined by turning the equipment off and on, the user is encouraged to try to correct the interference by one or more of the following measures: 1) Reorient or relocate the receiving antenna. 2) Increase the separation between the equipment and receiver. 3) Connect the equipment to an outlet on a circuit different from that to which the receiver is connected. 4) Consult the dealer or an experienced radio/TV technician for help.

This device complies with **RSS-210 of Industry Canada**.

Operation is subject to the following two conditions:

- (1) This device may not cause harmful interference, and
- (2) This device must accept any interference received, including interference that may cause undesired operation.

Le présent appareil est conforme aux CNR d'Industrie Canada applicables aux appareils radio exempts de licence. L'exploitation est autorisée aux deux conditions suivantes:

- 1. l'appareil ne doit pas produire de brouillage, et*
- 2. l'utilisateur de l'appareil doit accepter tout brouillage radioélectrique subi, même si le brouillage est susceptible d'en compromettre le fonctionnement.*

This Class B digital apparatus complies with Canadian ICES-003.

Cet appareil numérique de la classe B est conforme à la norme NMB-003 du Canada.

For RF Safety and per FCC and Industry Canada regulations, the product should never be installed within 8-inches (20cm) of typical people locations.



Table of Contents

1: BEFORE YOU BEGIN	5
1.1: GENERAL REQUIREMENTS:	5
1.2: POWERNET READER-CONTROLLER SPECIFICATIONS:	6
1.3: INSTALLATION LOCATION GUIDELINES	7
1.4: INSTALLER TOOLKIT COMPONENTS	9
1.5: POWERNET CONFIGURATION	10
2: WIRING AT THE DOOR AND READER-CONTROLLER	12
2.1: POWERING THE READER-CONTROLLERS	12
2.1.1: POWER OVER ETHERNET (PoE) OPTION	12
2.1.2: ADDITIONAL POWER OPTIONS	14
2.2: WIRING THE DOORS	17
2.2.1: READER-CONTROLLER CONTROL-LEADS DESCRIPTION	18
2.2.2: LOCK WIRING -- BASIC	20
2.2.3: WIRING THE REX BUTTON	23
2.2.4: WIRING THE AUX INPUT	23
2.2.5: WIRING THE DOOR SENSE	24
2.2.6: LOCK WIRING -- LOW-VOLTAGE 12VDC POWER OPTION	25
2.2.7: LOCK WIRING -- EXTERIOR DOOR KIT	26
2.2.8: EDK LED STATUS INDEX	28
2.2.9: LOCK WIRING -- 2 READERS TO 1 LOCK	29
2.2.10: USING THE TTL LEADS	30
2.2.11: USING THE POWERNET'S RS-232 INPUT	30
2.2.12: WIRING THE WIEGAND INTERFACE MODULE	31
2.2.13: WIRING THE DUAL-SRM	33
2.2.14: WIRING THE QUAD-SRM	35
2.2.15: MANAGING INDUCTIVE LOAD CHALLENGES	37
2.2.16: MANAGING IN-RUSH CURRENT LOADS	38
2.3: CONFIGURATION EXAMPLES	39
2.3.1: PoE --- ELECTRIC STRIKE	39
2.3.2: PoE --- EXTERNAL PWR FOR ELECTRIC STRIKE	40
2.3.3: 12VDC – ELECTRIC STRIKE	41
2.3.4: PoE --- MAGNETIC LOCK	42
2.3.5: PoE --- MAGNETIC LOCK & PIR	43
2.3.6: PoE --- MAGNETIC LOCK, EDK & PIR	44
2.3.7: DUAL POWER SOURCES	45
3: CONFIGURING THE READER-CONTROLLER'S COMMUNICATIONS	46
3.1: ETHERNET-BASED TCP/IP READER-CONTROLLERS	46
3.2: SECURING MESSAGES ON YOUR NETWORK	49

Document Version

Date of Revision	Revision	Author	Description
9/14/2012	2.16	Shirl Jones	Updated for the RC03 model. Added descriptions of alternate power options
9/17/2012	2.17	Shirl Jones	Minor edits
10/7/2012	2.18	Shirl Jones	Added WIM and SRM sections.
11/27/2012	2.19	Shirl Jones	Updated FCC statements
1/23/2013	2.20	Shirl Jones	Updated PowerNets current specs
3/4/2013	2.21	Shirl Jones	Added Tool Kit guidelines.
7/10/2013	2.22	Shirl Jones	Expanded jumper pin descriptions
8/12/2013	2.23	Shirl Jones	Expanded Wiegand Device guidelines
9/18/2013	2.24	Shirl Jones	Minor Edit on RFID modulation spec
02/06/2014	2.25	Shirl Jones	Added input power tolerances.
02/26/2014	2.26	Shirl Jones	Described In-Rush's BackEMF diode
03/05/2014	2.27	Shirl Jones	Expanded EDK wiring instructions
03/28/2014	2.28	Shirl Jones	Described use of Diode Assy, and French version of RSS-210 statement.
4/25/2014	2.29	Shirl Jones	Updated EDK wiring description
6/25/2014	2.30	Shirl Jones	Updated InRush Suppressor w/new design

1: BEFORE YOU BEGIN

To install an ISONAS Reader-controller unit, you must complete three key wiring tasks:

1. Supply power to the Reader-controller unit. This may be accomplished with a power feed on the Ethernet Data cable (Power over Ethernet [PoE]) or through an external DC power source (12VDC or 24VDC)
2. Wire the unit to the door's locks and other components for physical access control.
3. Connect the unit to the data network for communication with the server/workstation host PC.

This guide discusses each wiring process separately. Understanding all of these processes makes a project much simpler and guarantees success.

1.1: GENERAL REQUIREMENTS:

- If PoE is not being used, then use only UL-listed, access control, power-limited power supplies with an 'AC on' indicator light clearly visible on the enclosure. Power supplies should provide at least four hours of standby power.
- Never connect power supplies to a switch-controlled receptacle.
- Install the ISONAS system in accordance with the National Electrical Code NFPA 70. (Local authority has jurisdiction.)
- Use only wire or UL-listed cabling recognized suitable for ISONAS power supply and data communications, in accordance with the National Electrical Code.
- Where possible, separate ISONAS equipment and cabling from sources of electromagnetic interference (EMI). Where this is not possible, take other steps to reduce the effect of EMI on cabling or equipment.
- Protect input and output terminals adequately from transient signals. Also, connect these terminals to power-limited circuitry.

1.2: POWERNET READER-CONTROLLER SPECIFICATIONS:

Input Voltage	12 VDC (8.0V to 14.5V); 24 VDC (23.0V to 54.0V); or PoE per IEEE 802.3af
Input Current Draw	< 0.125 AMPS @ 12VDC < 0.070 AMPS @ 24VDC
Supplied Power for External Devices (when PoE power is being used)	0.60 AMPS @ 12VDC
Read Range	3 TO 5 inches typically
Read Speed	<250msec (Prox)
Exciter Field Frequency	Proximity -- 125khz Multi-Tech - 13.56 MHz
Modulation Schemes	Proximity -- FSK Multi-Tech --ISO 14443 type A and type B
Communication Interface	TCP/IP Over Ethernet 10 Mbps, ½ duplex
Inputs/Outputs	3 Inputs/2 TTL Outputs/1 Tamper Input
Relay	2.0 amp @ 30V DC (Resistive load)
Standalone Memory Capacity	64000 Cards/ 5000 Events/ 32 Time zones
Visual Indicators	2 LEDs for Normal Operations
Operating Temperatures	-40° To 122° Fahrenheit -40° To 50° Celsius
Weight	Mullion Approximately 8 Ounces
Size	Mullion 6 ¾"H BY 1 5/8"W

1.3: INSTALLATION LOCATION GUIDELINES

When selecting the location where you are going to mount the ISONAS reader-controller, a few guidelines should be observed.

- 1) The reader-controller should be kept at least 2 feet from another ISONAS reader-controller, and 6 feet from any other RF emitting device.
- 2) Assure that the window on the back of the reader-controller's is mounted against a reflective surface. A self-adhesive reflective sticker is provided with each reader-controller, in case the wall's mounting surface is non-reflective. Please note that this reflective surface is required for successful operation of the ISONAS reader-controller
- 3) In an exterior location, the reader-controller's mounting should be sealed to prevent water from running down between the mounting surface and the back of the reader-controller.
- 4) For the PowerNet reader, a dielectric insulating compound (Dow Corning DC-4 or equivalent) can be used to obtain extra water protection of the reader-controller's cable connections.
- 5) The reader-controller should be protected from extreme heat and sunlight. It is rated for conditions up to 120 F. A direct southern exposure, in the Southwest area of the United States may exceed these ratings.
- 6) For a few installations, mounting the reader against a large metal object may reduce the read range of the reader. Steel, iron, and copper will have more of an effect on the read range than aluminum. If the PowerNet will be mounted on a steel surface we recommend being prepared to mount a pad ("1 to 3" inches in depth) between the reader and the metal frame. Then during the installation phase and before final mounting of reader test the reader's read range to make sure it is acceptable. If not, then insert the pad between the reader and the steel surface to improve the read range.
- 7) The cables extending from the back of the PowerNet's Pigtail cable comes in a standard 4 ft length. 10 ft and 25 ft lengths Pigtails are optionally available. Plan for terminating the door wiring within that distance of the reader-controller.
- 8) The wall mounting features required for the reader-controller are shown in the next figure. Electronic versions of this figure can be found on the ISONAS website, and can be printed out, for use as life-size drill templates.

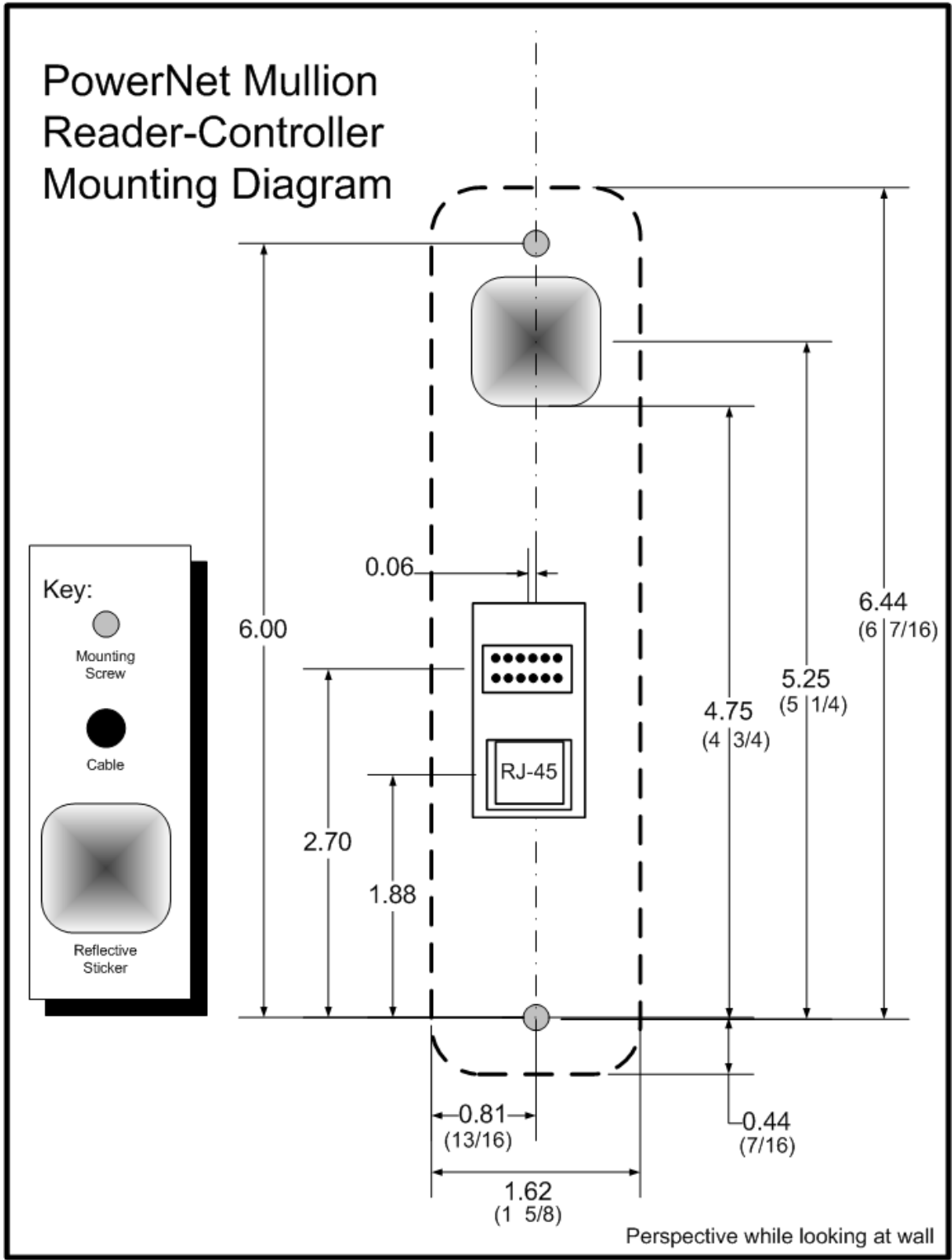

Figure 1 (PowerNet Mullion Mounting Diagram)

1.4: INSTALLER TOOLKIT COMPONENTS

Before an installer goes to a customer site, they need to put together their supplies and tool-kit. The ISONAS solution is simpler to install than other Access Control Systems, but materials are still needed. And some of those materials may be different than what you are use to carrying. The list below identifies some important items that you should make sure to bring with you, to the customer's site.

A prepared installer will have:

Installer completed the on-line reseller training program.

An installer's Tool Kit should include the following:

- 1. The copy of the PowerNet Installation and Wiring Guide**
- 2. A Volt-Ohm Meter**
- 3. A laptop with Crystal Matrix installed**
- 4. A PoE Injector**
- 5. A Cross-over Cat5/Cat6 cable**
- 6. A straight-thru Cat5/Cat6 patch cable.**
- 7. Basic Ethernet network cable tester (Tests for: Opens, Shorts, Split Pairs, Mis-wires & Reversals)**
- 8. A spare PowerNet**
- 9. An extra PowerNet Pigtail**
- 10. Silicon Caulking for sealing the PowerNet to exterior walls**
- 11. Dielectric Silicon Grease (Dow DC-4) for protecting cable terminations.**
- 12. The ISONAS As-Built forms, which is used to record the details of the door's installation.**
- 13. Credentials that match the customer system's technology**
 - **ISONAS Proximity**
 - **HID Proximity**
 - **Smart Cards (ISO 14443)**

The customer's Crystal Matrix system should have Internet access. This enables the use of on-line meeting tools, such as GoToMeeting, during any remote support sessions.

1.5: POWERNET CONFIGURATION

The PowerNet reader-controller has a set of jumper pins that configure both its input power source, and its lock control circuit.

The PowerNet reader-controller can be configured for power to be supplied to the reader-controller through the 12 conductor pigtail (either 12VDC or 24VDC) or through the RJ45 connector (Power Over Ethernet).

If POE is used, the reader-controller can supply 12VDC thru its pigtail, which may be used to power the lock or other devices at the door location.

Note: The RC03 has an additional set of jumpers. These jumpers **should not** be changed. The jumpers are set at the factory, based on the PowerNet's internal hardware.

If these jumpers are changed, the PowerNet **will not operate**

correctly.

If accidentally moved, replace the jumpers to the positions shown.

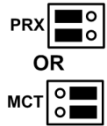

OR

Figure 2 shows the components on the back of the ISONAS PowerNet Reader-controller.

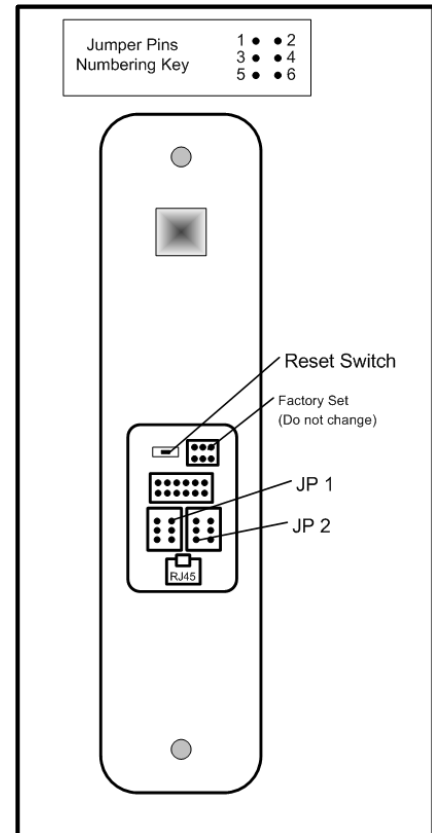

Figure 2

Feature	JP 1 Jumpers	JP 2 Jumpers
Input Power – 12VDC, thru Pigtail	1 to 3	
Input Power -- 24VDC, thru Pigtail	3 to 5 & 4 to 6	
Input Power – PoE, thru RJ45 connector	None	
Input Power – PoE, thru RJ45 connector (See Note 1)	1 to 3	
Input Power – No affect, place-holder for extra jumper	2 to 4	
Lock's power/signal is externally supplied on the pigtail's pink wire		None
Supply internal 12VDC to relay common (See Note 2)		1 to 3
ISONAS External Door Kit being used.		4 to 3
Connect GROUND to relay's common contact.		5 to 3

Note 1. Special case: The unit is PoE powered AND you want 12v output power supplied on the pigtail's red conductor.

Note 2. Used when powering an external lock device. This option only available if JP 1 configured for PoE.

1.6: POWERNET READER-CONTROLLER RESET BUTTON

The PowerNet reader-controller has a Reset Button located on the back. It can be used for two different types of resets.

It is helpful if the PowerNet's Ethernet cable is connected, and functioning (the amber LED is lit). Monitoring the amber LAN status LED allows you to determine the status of the reset operation.

● **Reset CPU:** Press, hold (approx. 2 seconds) and release the Reset button. Once the Reset Button is released, the Amber LAN Status LED should turn off (approx. 6 seconds), and then turn back on. If the Amber LED does not turn off, then the reset did not occur.

● **Reset Configuration:** Press and hold the Reset button (approx. 10 seconds), until the Amber LAN LED turns off. Selected reader-controller configuration is reset to factory defaults. Setting that are changed include:

- IP Address (Default value: 192.168.1.119)
- IP Port (Default value: 10001)
- Subnet Mask (Default value: 255.255.0.0)
- Gateway (Default value: 0.0.0.0)
- DHCP Setting (Default value: Off)
- ACS Server (Default value: SrvrAcs)
- ACS Server IP (Default value: 0.0.0.0)
- Serial Port (Default values: 9600, 8, N 1)
- Clear AES Encryption Configuration
- Reset PowerNet's Passwords

2: WIRING AT THE DOOR AND READER-CONTROLLER

2.1: POWERING THE READER-CONTROLLERS

All ISONAS Reader-controller models require a direct connection to a power source.

The PowerNet reader-controllers can be powered with **12 volts DC, 24 volts DC, or PoE (IEEE 802.3af) power** and the supply must be regulated. Many brands of power sources work well with ISONAS equipment. For the PowerNet reader-controller, the desired input power selection is made thru the use of the jumper pins. See previous section (1.4) for the description of the usage of these jumper pins.

2.1.1: POWER OVER ETHERNET (PoE) OPTION

If you are installing ISONAS PowerNet readers, then you can use the Power Over Ethernet (PoE) option. PoE allows one cable to supply data and power to both the Reader-controller and an Electronic lock. The obvious savings here is that you only need to run a single CAT5 cable to the door which will provide enough power to run both the ISONAS Reader-controller and an electronic lock. If you are not familiar with PoE, please take a moment to read the PoE document located on the ISONAS web site.

If your network switch is equipped to provide PoE power, then the separate PoE Injector is not required.

If used, the PoE Injector is normally located right next to your existing network hub/switch, and the Injector itself is plugged directly into a standard AC outlet, or for extra security, a UPS battery backup.

Figure 3 is an overview of how to use PoE to power both the ISONAS PowerNet Reader-controller and an electronic locking mechanism.

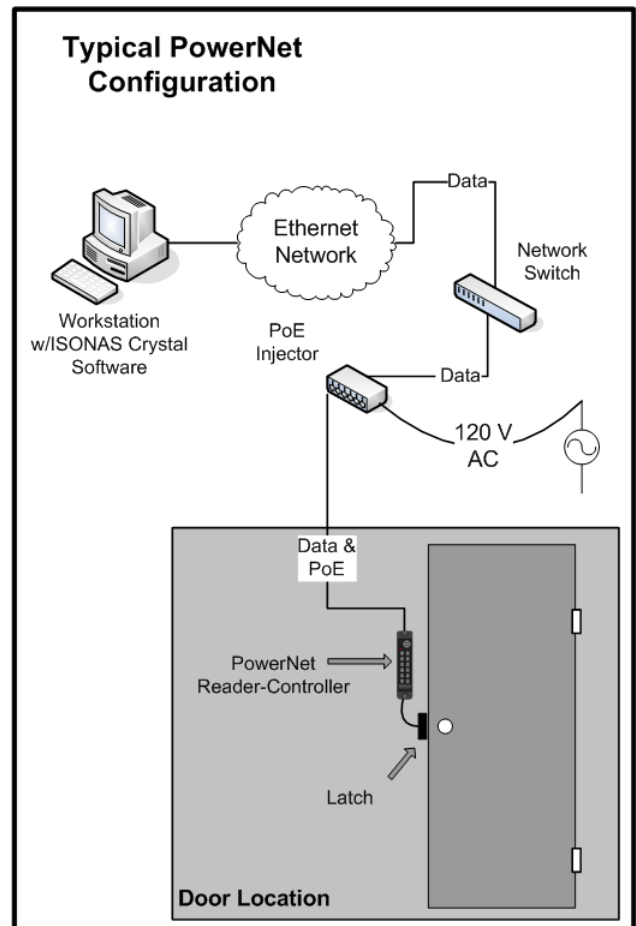

Figure 3

A standard CAT5 cable is then run between the PoE source (Injector or switch) and the PowerNet Reader-Controller which will be located right next to the door. The CAT5 cable can be up to 100 Meters (328 feet) long.

With one cable, you provided the required network connection and all the power that will be needed at the door site.

PowerNet Supplying 12 VDC to Door Components

When using PoE, the PowerNet reader can supply 0.6 amps@12 Volts of power for the external door components. This power can be routed to the lock control circuit using the jumper pins. The supplied 12V power can also be accessed thru the reader-controller's Pigtail, when the reader's jumper-pins are properly configured (on Jumper block JP1, jumper pin 1 to pin 3). The power will be continuously available on the Pigtail's Red and Black conductors. You might use this 12VDC source to power a Motion Detector located at the door location.

PoE Power Budget Calculations

When planning an installation using PoE, you need to assure that the PoE source (PoE Injector or PoE equipped Network Switch) supplying the PoE power is sized properly for the power draw of all the doors. To do this, you total up the power draw (in watts) of the PoE connections, and compare that total power draw to the rated capacity of the PoE source.

Below is a chart of expected PoE power draws of the ISONAS Reader-controllers.

Door Location Configuration	PoE Power Requirement ** (Watts)
PowerNet Reader-Controller	3.0 Watts
PowerNet Reader-Controller with Electronic Lock (0.6 amp @ 12V)	11.0 Watts

*** Ethernet cabling power losses not included. Losses range from being negligible for short Cat5 cables up to about 16% for 100 meter Cat5 cables.

To meet the PowerNet's variable PoE power requirements, the PowerNet will classify itself with the PoE source as a "Class 0" PoE device. The power usage of a Class 0 device can range between 0.4 to 13.0 watts at the device (up to 15.4 watts from the PoE source).

Some network PoE equipment will budget and allocate its distribution of PoE power based upon the maximum power usage of the each attached device's classification. If your network equipment uses this power provisioning technique, then you should budget 15.4 watts for each PowerNet. Such network PoE Equipment may allow you to manually configure the amount of power that should be allocated to each device. Configuring the PoE equipment for an allocation of 3.0 watts or 11.0 watts per connection would be appropriate.

2.1.2: ADDITIONAL POWER OPTIONS

Most installations will use PoE for the PowerNet and door locks. That is a clean way to control a door using a single, standard network cable.

There are many additional options available, that can be used, if the door location requires more power than a standard PoE-powered PowerNet can provide.

The different options require different configurations of the supporting equipment and /or building wiring. The following chart and **Figure 4** describes some of these power options.

Power Source	Switchable Power (Max)	Equipment at the Door	Limiting Factor	Topology Diagram
PoE (802.3af)	0.60 amps (12VDC)	PowerNet	PowerNet's available PoE Output	A
PoE (802.3af)	0.55 amps (12VDC)	PowerNet EDK	PowerNet's available PoE Output { minus } the power required by the EDK	B
DC Power Supply 12 or 24 VDC	2.0 amps (As supplied) (RC02: 1.0A)	PowerNet	Rating of PowerNet's lock relay	C
DC Power Supply 12 VDC	3.0 amps (12VDC)	PowerNet EDK	Rating of EDK's lock relay (12VDC required by EDK's internal circuitry)	D
High-Powered PoE (802.3at)	1.8 amps (12VDC) (RC02: 1.0A)	PowerNet PoE Splitter Example PoE Splitter PowerDsine PD-AS-701/12	Rating of PoE Splitter { minus } power required to operate PowerNet	E
High-Powered PoE (802.3at)	1.8 amps (Approx) (12VDC)	PowerNet EDK PoE Splitter Example PoE Splitter PowerDsine PD-AS-701/12	Rating of PoE Splitter { minus } power required to operate PowerNet & EDK	F
High-Powered PoE (non-standard) Example PoE Injector PowerDsine PD-9501G	3.00 amps (12VDC)	PowerNet EDK PoE Splitter Example PoE Splitter PowerDsine PD-AS-951/12-24	Rating of EDK's lock relay	G

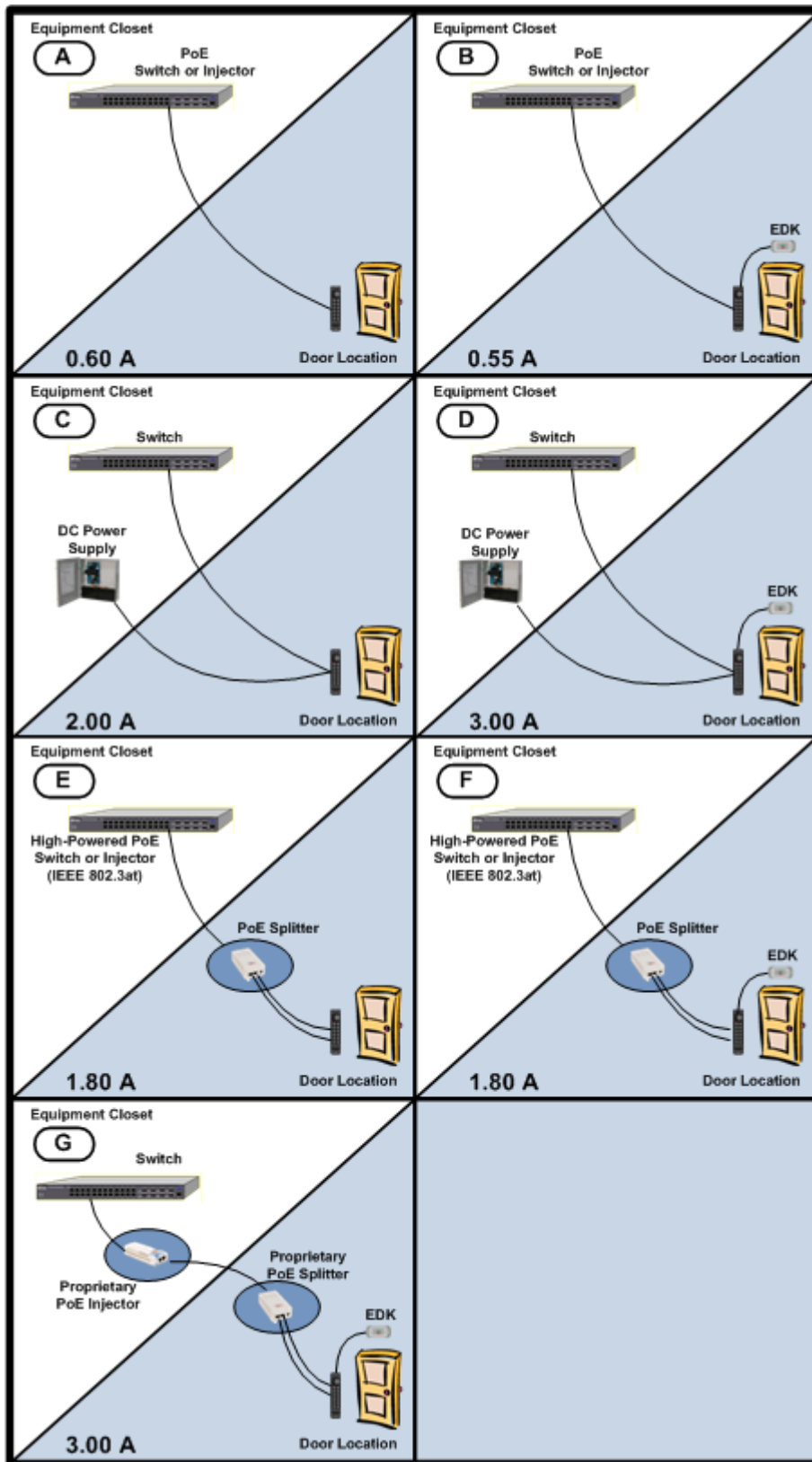

**Power Options
Figure 4**

2.2: WIRING THE DOORS

After you connect power to every controller, the next step is to connect the door.

Wiring a door may involve connecting:

- An electronic door latch
- A request to exit (REX) like:
 - REX Button
 - Motion Detector
- An auxiliary (AUX) button
- Door sensors
- TTL lines (TTL1 and TTL2)

Figure 5 shows the typical configuration at the door.

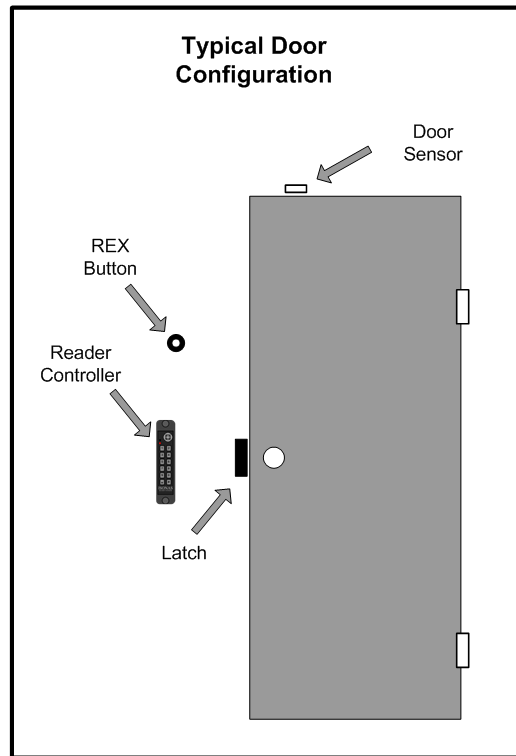

Reader-wiring at each

of equipment

Figure 5

2.2.1: READER-CONTROLLER CONTROL-LEADS DESCRIPTION

The reader-controller has a cable extending from its back plate that is referred to as “the pigtail”. The pigtail consists of 12 wire leads (22 awg) which are used to connect to the various components at the door location. Most installations do not require the use of all the leads. The typical usage of each available lead is shown in **Figure 6**.

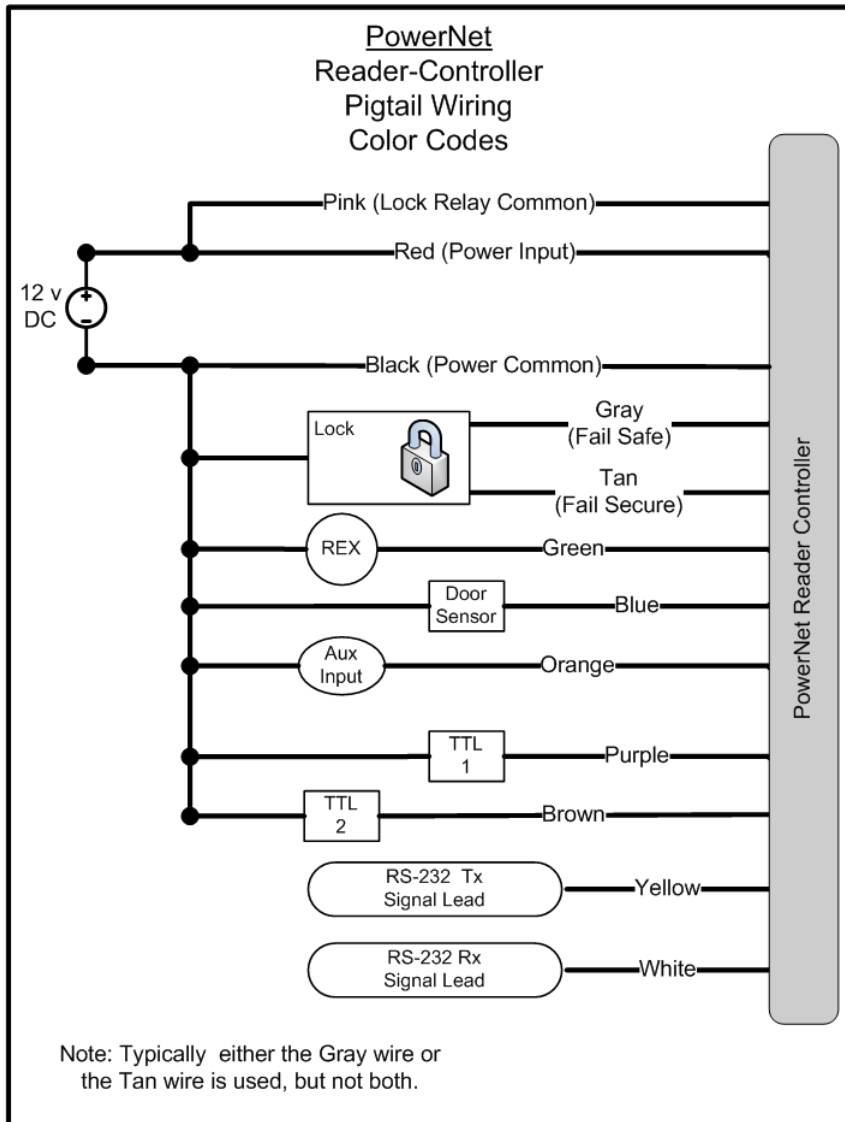

Figure 6

One of the wires is for a door sense switch. Another is for a REX (Request for Exit) signal coming from a switch, infrared sensor or other REX device. A third input signal, called AUX (auxiliary), can be programmed to act in a variety of ways.

The controllers have a lock-control circuit. This circuit consists of a form-C relay, with its “normally open”, “normally closed” and “common” contacts connected to three leads of the pigtail. These pigtail leads can be directly connected to the electronic lock to unlock the door when a valid credential is presented.

There are two additional output signals called TTL1 and TTL2 that can be programmed to behave in a variety of ways.

The usage of each lead will be detailed in the next few pages.

2.2.2: LOCK WIRING -- BASIC

Electronic door lock Overview:

If the door does not already have an electronic lock, first install the electronic door lock according to the manufacturer's instructions. Examine the lock to determine whether applying power will lock or unlock the door.

●**Fail Safe:** If applying power locks the door (usually magnetic locks), use the gray wire labeled (NC).

●**Fail Secure:** If applying power unlocks the door (usually electric strike locks), use the tan wire labeled (NO).

Most locking mechanisms have **two leads for the power coil**. On an electric strike, the leads power a solenoid. On a Mag Lock, the leads power an electromagnet.

The door lock control relay inside the ISONAS Reader-Controller has a set of Form "C" contacts that are rated at 1.0 amp @ 30V DC. This means it can handle most locking mechanisms. If your application requires more voltage or amperage than this, an external relay that is controlled by the reader/controller can be used.

Installation Tip

For non-PoE installations:

Before you start wiring an electronic door lock, check that its power source is separate from the power source for the Reader-controller at that door.

Voltage fluctuations caused by using the same power source for both devices may cause the Reader to malfunction.

Generic Wiring, using External Power for the Lock: See Figure 7

1. The PowerNet itself is being powered by PoE.
2. Connect the positive side of the power supply to the **pink (common)** wire on the ISONAS Reader.
3. For a Fail Safe lock, connect the **gray (Normally Closed (NC))** wire on the ISONAS Reader-controller to one lead of the electric lock. For a Fail Secure lock use the Reader's **tan (Normally Open (NO))** wire instead.
4. Wire the other lead of the lock to the **Black** wire on the power supply.

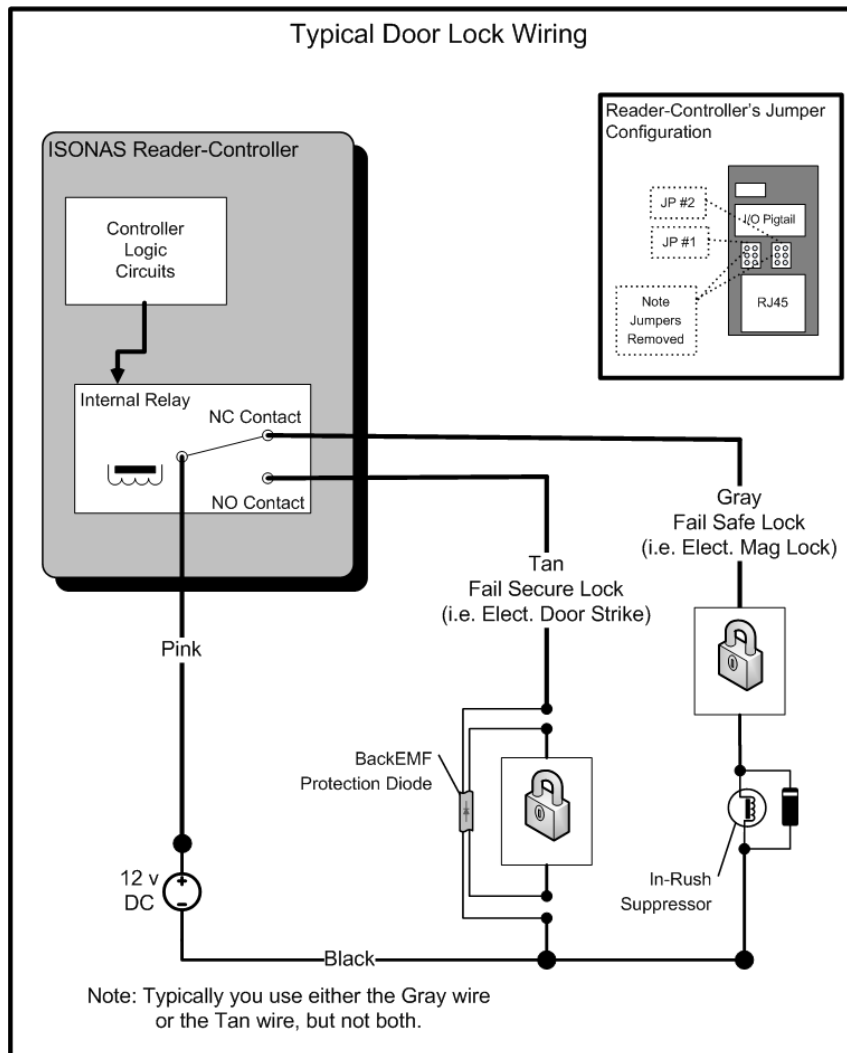

Figure 7

Generic Wiring, using PoE: See **Figure 8**

The PowerNet supports a simplified configuration when PoE is being used to supply the lock's power.

1. Assure that the jumpers are configured as shown:
JP1: Pins 2 to 4
Or
No jumper

JP2: Pins 1 to 3.
2. For a Fail Safe lock, connect the **gray (Normally Closed (NC))** wire on the ISONAS Reader-controller to one lead of the electric lock. See In-Rush suppressor section for more info.
3. For a Fail Secure lock use the Reader's **tan (Normally Open (NO))** wire instead. See BackEMF diode section for more info.
4. Connect the other lead of the lock to the **black** wire on the ISONAS reader-controller.

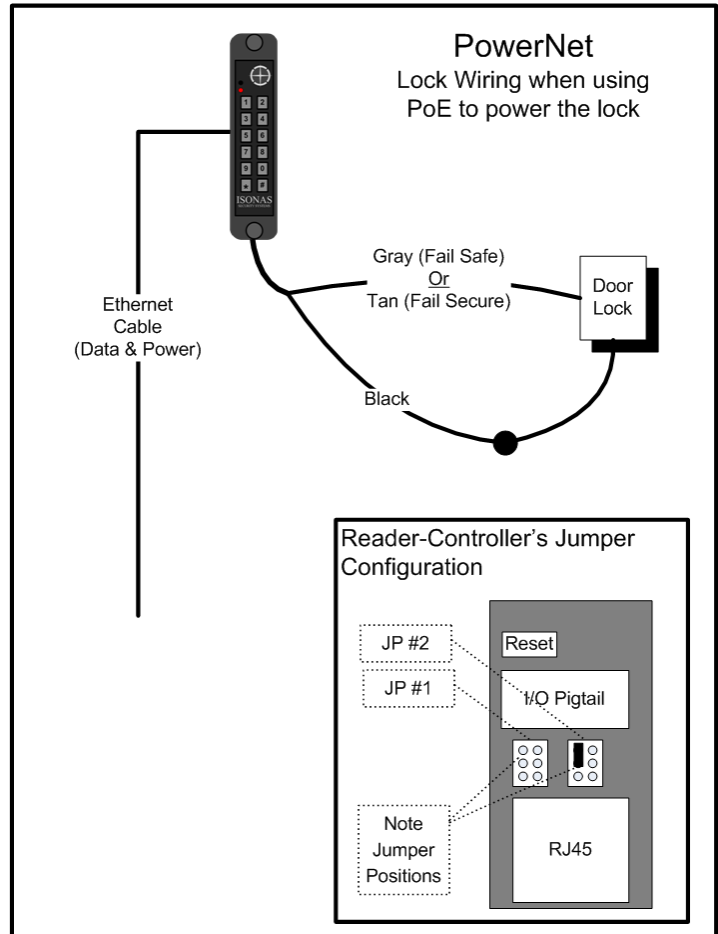

Figure 8

Additional Lock Circuit wiring Notes:

There are many additional ways that the lock-control circuit can be used. Examples include: Gate Controllers, Intelligent locking mechanisms, and Fuel pumps.

The general guidelines for using the Lock-Control Circuit are:

1. Always keep the voltage under 30 volts, and the current under 1 amp.
2. Use the Tan lead, if electrical current flow will unlock the door.
3. Use the Gray lead, if electrical current flow will lock the door.
4. Use the Pink Lead, if external power is being used to power the lock.
 - a. Otherwise you may supply 12VDC power to the lock relay by using the jumper pins as shown in **Figure 8**.

2.2.3: WIRING THE REX BUTTON

The REX (Request for Exit) signal expected by ISONAS Reader-controllers is a **momentary closure**. You can generate this signal with a pushbutton, infrared motion detector, or other simple device. Typically the REX is placed adjacent to the door so that people can press the button and let themselves out the door without setting off the alarm. When pressed, this button tells the ISONAS Reader-controller that someone wishes to pass through the door, and the latch releases. In the ISONAS Crystal software you can configure how the door responds to the REX button.

About REX and AUX

REX and AUX are both normally open inputs. No action is taken until the input is closed.

You must wire this switch through the ISONAS Reader-controller. (See **Figure 9**) First, connect one terminal of the momentary switch to the Reader's **green wire**. Then, connect the switch's other terminal to the Reader's common **ground wire (black)**.

2.2.4: WIRING THE AUX INPUT

In host mode, the AUX Input is another momentary switch which functions exactly like the REX button. (See **Figure 9**) The AUX Input might be controlled by a relay on an intercom at the door. This would allow the receptionist to unlock the door using the intercom system's functionality.

In the ISONAS Crystal software you can configure how the door responds to the AUX button.

In local mode, the door will stay unlocked while the AUX switch is closed.

Wiring for the AUX button is similar to that of the REX button. First, connect one terminal of the momentary switch to the Reader's **orange wire**. Then, connect the switch's other terminal to the Reader's common **ground wire (black)**.

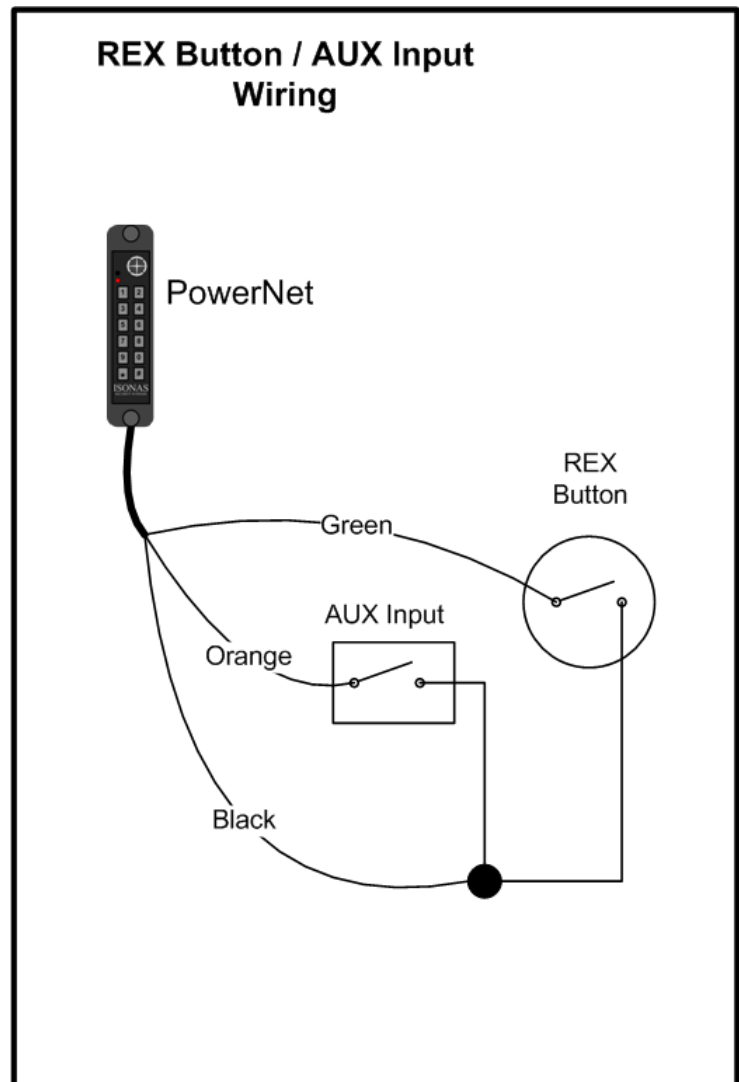

Figure 9

2.2.5: WIRING THE DOOR SENSE

Connecting the ISONAS Reader-controller to a door sensor allows our Crystal software to determine whether that door is physically open. Then the Crystal software can create alarms based on the door's state. This wiring task is similar to wiring the REX or AUX buttons.

First, connect one terminal of the door sensor to the Reader's **blue wire**. Then connect the door sensor's other terminal to the Reader's common **ground wire (black)**.

Figure 10 shows how to wire the door sensor.

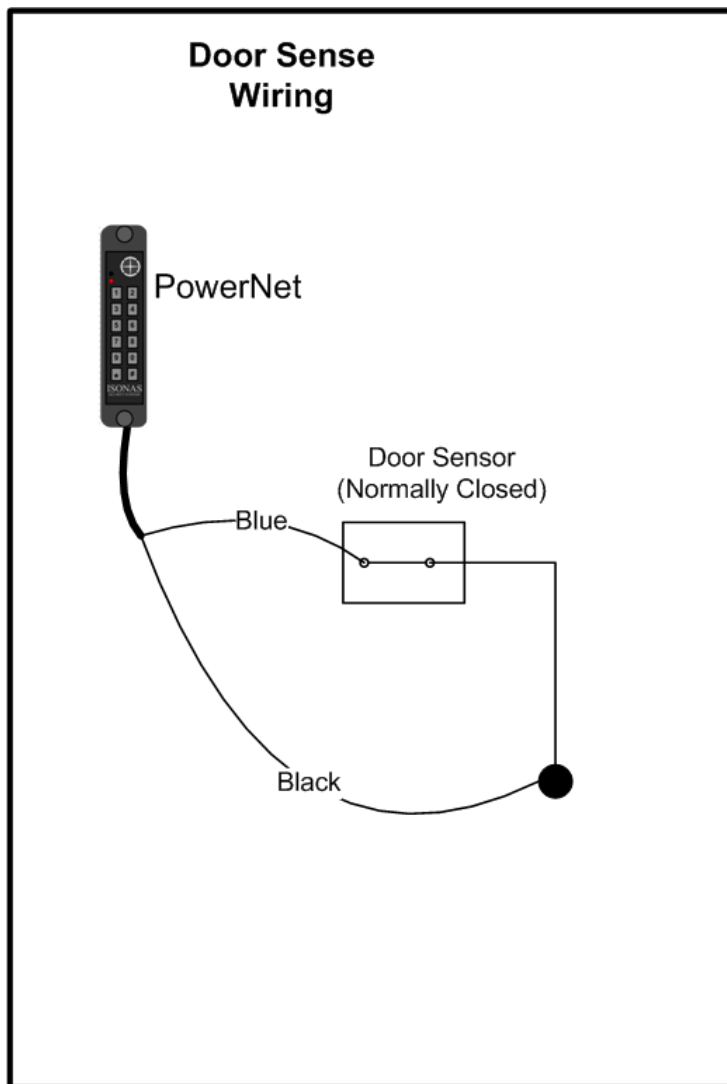

Figure 10

About the Door Sense

The door sense is a normally closed input. No action is taken until the input is opened.

IMPORTANT: If There's No Door Sense Switch

If you choose NOT to install a door sense switch, then you **must permanently ground** the door sense input (blue wire) to the reader's Black wire, so the system will not see the door as "open."

2.2.6: LOCK WIRING -- LOW-VOLTAGE 12VDC POWER OPTION

Powering the reader-controller using low-voltage DC:

Wiring DC power to a Reader-controller: Simply run the positive and negative wires from the power source to the positive and negative wires on each Reader. The example below shows the typical power connection for a reader-controller and a lock.

1. Connect the positive power from the power supply to the positive power connection (red lead) of the reader-controller. Install the Jumper pins as shown, which provides 12VDC to the lock circuit.
2. Connect one side of the electric lock to EITHER the Tan (Fail Secure) or Gray (Fail Safe) connection on the reader-controller. See BackEMF diode or In-Rush suppressor sections for more info.
3. Connect the negative power from the power supply to the negative power connection (black lead) of the reader-controller and the remaining side of the electric lock.

Figure 11 shows how to take the power from the External Power supply and drive both the PowerNet Reader-Controller and an Electronic lock.

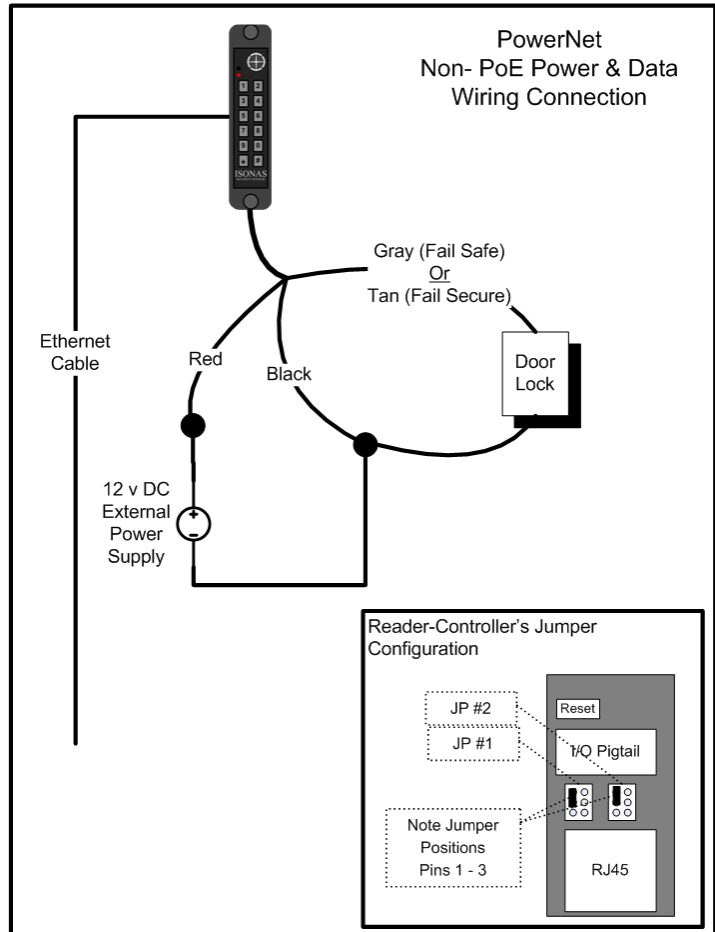

Figure 11

2.2.7: LOCK WIRING -- EXTERIOR DOOR KIT

The PowerNet reader-controller has an optional Exterior Door Kit (EDK), which allows you to isolate the door's lock control circuitry on the secure side of the building. Also, since the EDK is rated for 3 amps of current @ 12 Volts, it can be used in cases where the locking mechanism requires more current than the reader-controller's control circuit is rated for.

Two methods of connecting the EDK are shown

The 1st example shows powering both the lock and the EDK with the Reader-controller's PoE power. See **Figure 12**

Installation Tip:

Jumper Block #1 and #2 should be configured as shown.

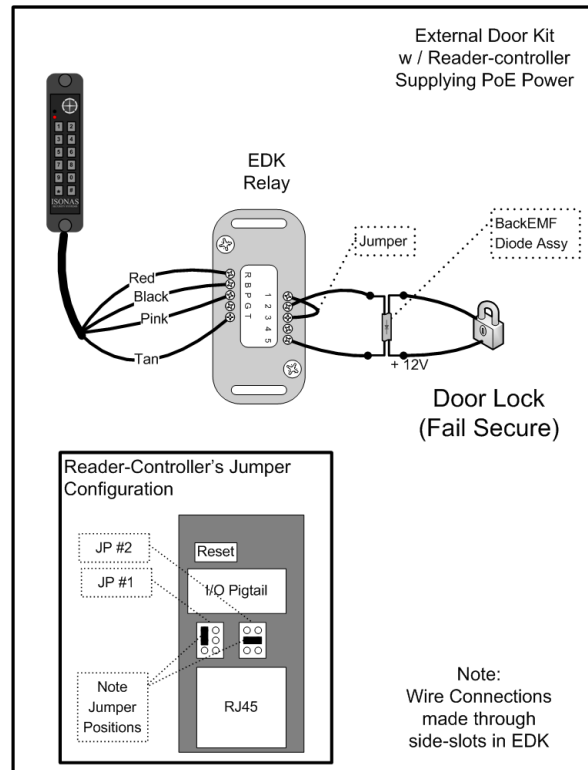

Figure 12

Label	Reader Side Connection	Label	Lock Side Connection
R	Pigtail's Red wire (12 V Input Power)	1	12V Output Power
B	Pigtail's Black wire (Ground)	2	Power Ground
P	Pigtail's Pink wire	3	EDK Relay's Common Contact
G	Not used	4	EDK Relay's Normally Closed (NC) contact (Fail-Safe Lock)
T	Pigtail's Tan wire	5	EDK Relay's Normally Open (NO) contact (Fail-Secure Lock)

EDK Wire Conductor Preparation:

Strip back the wire insulation: .25 to .275 (1/4 to 9/32) inches

Acceptable single conductor sizes: 26 gauge to 15 gauge

Acceptable two conductors sizes: 26 gauge to 15 gauge

Note for multi-stranded conductors:

Avoid allowing any stray wire strands from contacting the adjacent terminal block connection.

Twist the multi-strands together prior to insertion.

Lightly solder-tinning the exposed wire can help prevent stray strands.

The 2nd example shows powering the EDK with the Reader-controller's PoE power output, and the lock with an external 24 volt power supply. See **Figure 13**

Installation Tip:
Configure the Jumper Blocks as shown in previous example

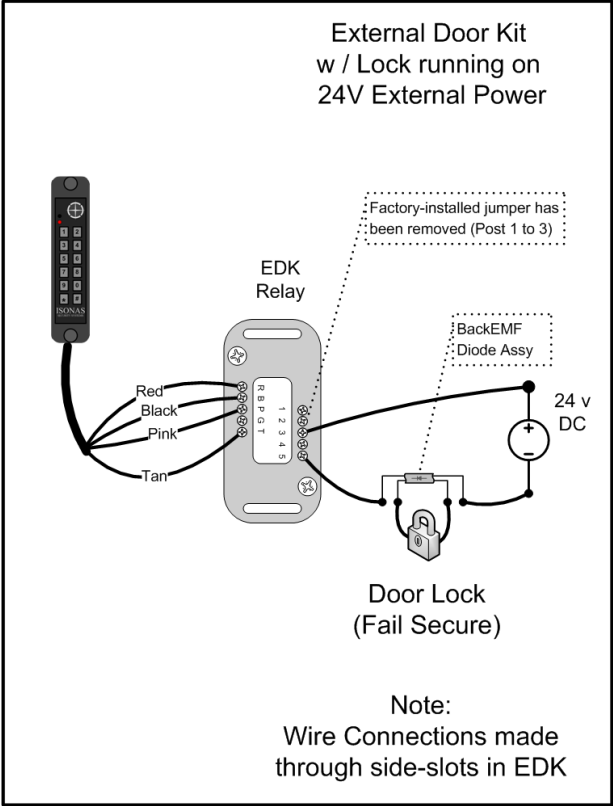

Figure 13

Label	Reader Side Connection	Label	Lock Side Connection
R	Pigtail's Red wire (12 V Input Power)	1	Not Used
B	Pigtail's Black wire (Ground)	2	Not Used
P	Pigtail's Pink wire	3	EDK Relay's Common Contact
G	Not Used	4	EDK Relay's Normally Closed (NC) contact (Fail-Safe Lock)
T	Pigtail's Tan wire	5	EDK Relay's Normally Open (NO) contact (Fail-Secure Lock)

2.2.8: EDK LED STATUS INDEX

The EDK has two status LEDs

Power LED:

Located on the side towards the PowerNet's pigtail.
A Red LED indicates 12VDC power is being supplied to the EDK.

Communication Status LED:

Located on the side towards the Lock wiring.
LED status meaning are described in the table below.

PowerNet Locked	PowerNet Unlocked	Lock State when PowerNet is unlocked	Description or Item to Check
Off	Green	Normal Operation	
Flash Amber	Flash Amber	No Operation	Pink wire may be disconnected
Off	Flash Amber	No Operation	Tan wire may be disconnected
Off	Flash Amber	No Operation	Invalid encryption key received from PowerNet
Off	Off	No Operation	If PowerCycle of PowerNet allows for one or more lock operations, and then the lock stops operating, then the BackEMF diode may not be installed correctly.

2.2.9: LOCK WIRING -- 2 READERS TO 1 LOCK

If you are wiring both sides of the door to control IN and OUT access, then you will have the special condition of wiring 2 Reader-Controllers to a single locking mechanism.

If there is not a door sensor switch connected to the door, then typically you connect both reader-controllers to the door's lock circuit.

For Fail-Secure locks, wire the two reader-controller's lock circuits in-parallel (Lock is connected to both reader-controller's **Tan** leads)

For Fail-Safe locks, wire the two reader-controller's lock-circuits in-series (**Gray** lead of Reader #1 connects to **Pink** lead of Reader #2, **Gray** lead of Reader #2 connects to lock).

If there is a door sensor switch connected to the door, then Reader #1 controls the door, and is wired to the door's Door-sense switch. Use the following steps to cause Reader #2 to activate the REX button on Reader #1.

Two Readers & One Lock Wiring Steps: See **Figure 14**

1. Wire reader #1 normally
2. Connect the **tan** (NO) lead from reader #2 to the **Green** (REX) lead on reader #1.
3. Connect the **pink** (common) lead from reader #2 to the **black** (ground) lead on reader #1.

Programming

Reader #1 must be programmed to accepted REX inputs

Installation Tip:

For Figure 11 -- Verify that there are no jumpers installed on Controller #2 `s JP 2 jumper block.

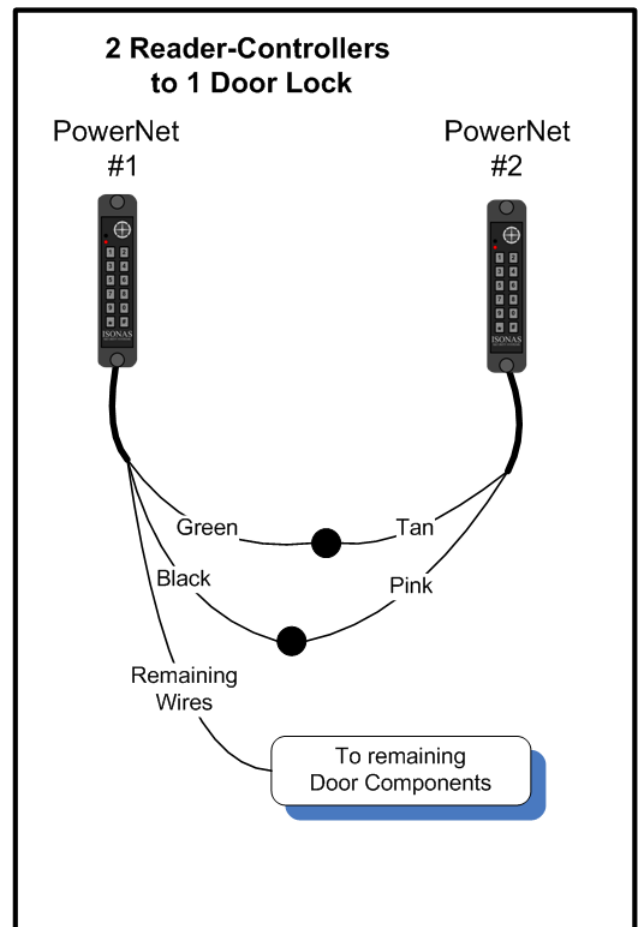

Figure 14

2.2.10: USING THE TTL LEADS

The **TTL1** and **TTL2** leads are logical output leads. In their “normal” state, there is a 5VDC potential on the leads. When the leads “activate”, this voltage potential is removed (0 VDC).

These leads are typically used to connect to an alarm system. Certain abnormal conditions of the reader-controller can be configured to activate these leads. An example would be having **TTL2** activate when the door is held open too long.

See the Crystal Access Software manual for more information on the usage of these leads.

2.2.11: USING THE POWERNET’S RS-232 INPUT

The pigtail’s RS-232 signal leads (Yellow & White) can be connected to an external device that will pass a credential ID to the PowerNet.

The most common usage is:

- To pass in a 2 to 9 character long ASCII data string.
- Only Numeric ASCII values are allowed in the string (“0” to “9”).
- Delimiter characters are typically used at the beginning and/or end of the message.

The serial connection’s default configuration is:

- 9600 Baud (Adjustable w/ PlugNPlay [9600, 19200, 38400, 57600])
- 8 Data Bits
- N Parity (Adjustable w/ PlugNPlay [N, E, O])
- 1 Stop Bit
- N Hardware flow control

2.2.12: WIRING THE WIEGAND INTERFACE MODULE

The ISONAS Wiegand Interface Module (WIM) allows the PowerNet to receive credential data from a Wiegand-based device, validate the credential, and then log that activity.

The WIM is an in-line module that is attached to selected conductors of the PowerNet's Pigtail.

Figure 15 shows how to wire the WIM.

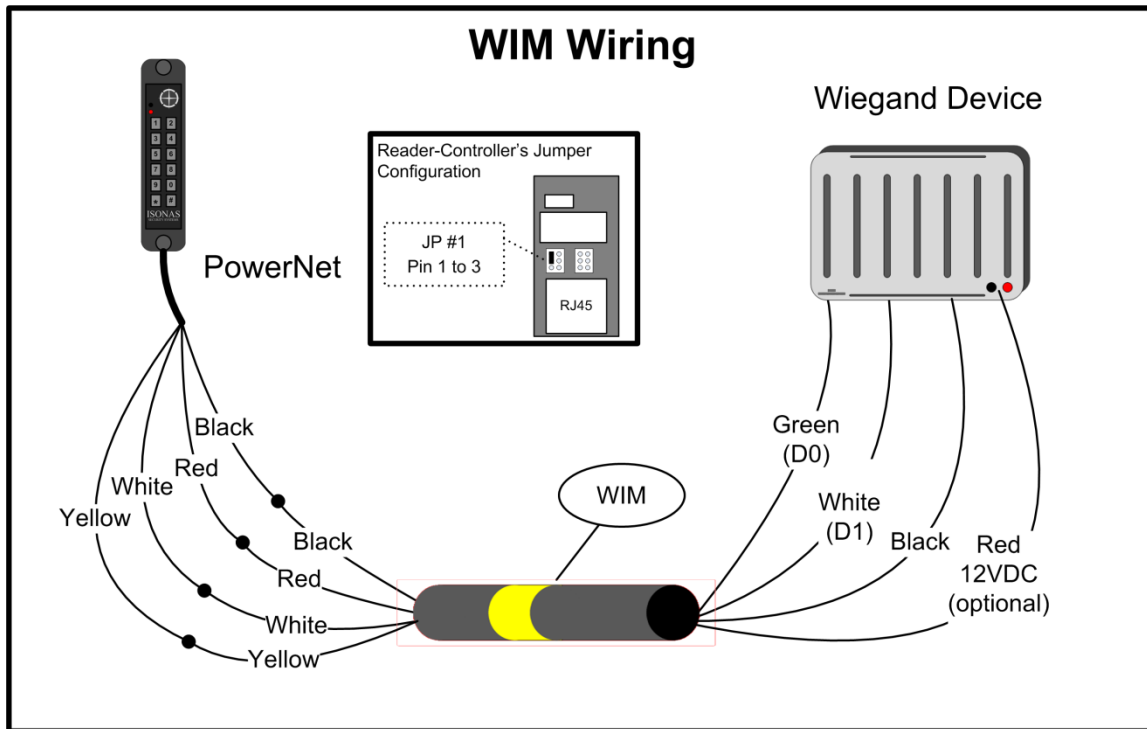

Figure 15

Note: The WIM is easily identified by a yellow stripe

The PowerNet can supply the 12VDC power required by the WIM. The PowerNet's jumper JP1 is used to control this. This same 12VDC power can also be used to power the Wiegand device. The WIM's output red wire provides a convenient connection to this power. Please make sure that the total power draw of the Wiegand device, lock, and other devices does not exceed the PowerNet's available power (0.60 amps). External power can be used, if the door components require additional power.

Wiegand Data

The Wiegand protocol has been used since 1980, so many devices exist that use this protocol.

The ISONAS solution can interpret the incoming Wiegand data in one of 3 ways.

- 1) As a raw 64 bit binary number, so the card format is not a factor.
- 2) As a HID formatted credential number, with the ISONAS Bit masking processing rules applied
- 3) As a HID formatted credential, with the ISONAS Data mangle processing rules applied.

The recommended system integrator evaluation process is to use either an IPBridge or PowerNet w/WIM and test against the existing hardware and credentials.

Validate that the reported credential data really uses the Wiegand protocol, and that the existing card format is handled appropriately.

If you need assistance, and can supply the appropriate materials to ISONAS, we will test your configuration at the factory

Required items include:

- A reader that is known to work with the currently installed equipment.
- 5 working credentials, to verify credential formatting.
- Installation instructions for the supplied reader, for power and operation instructions.

WIM's wiring color code

Color	Function
Red (PowerNet-side)	12 VDC Power
Black (PowerNet-side)	Ground (Power & Signal)
White (PowerNet-side)	RS-232 Transmit to PowerNet
Yellow (PowerNet-side)	RS-232 (Future use)
Red (Wiegand-Side)	12VDC connection (power from PowerNet)
Black (Wiegand-Side)	Ground connection (Power & Signal)
Green (Wiegand-Side)	DO signal from Wiegand Reader
White (Wiegand-Side)	D1 signal from Wiegand Reader

2.2.13: WIRING THE DUAL-SRM

The dual Secondary Relay Module (SRM) is available to enhance the PowerNet's ability to control devices located at the door.

The SRM provides a set of form-C relay contacts, which are controlled by one of the PowerNet's TTL outputs. There are multiple options available within the Crystal Matrix software to control the TTL outputs.

The SRM is commonly used to selectively control two locks, or to control a device located at the door, in addition to the door's lock.

Two example SRM usages are shown below.

Figure 16 shows a PowerNet controlling two locks. Note Tan wire's power supply can be configured by JP2. See section 2.2.2 of this manual for more details.

Figure 17 shows the PowerNet controlling an external device, in addition to the potentially controlling the door's lock.

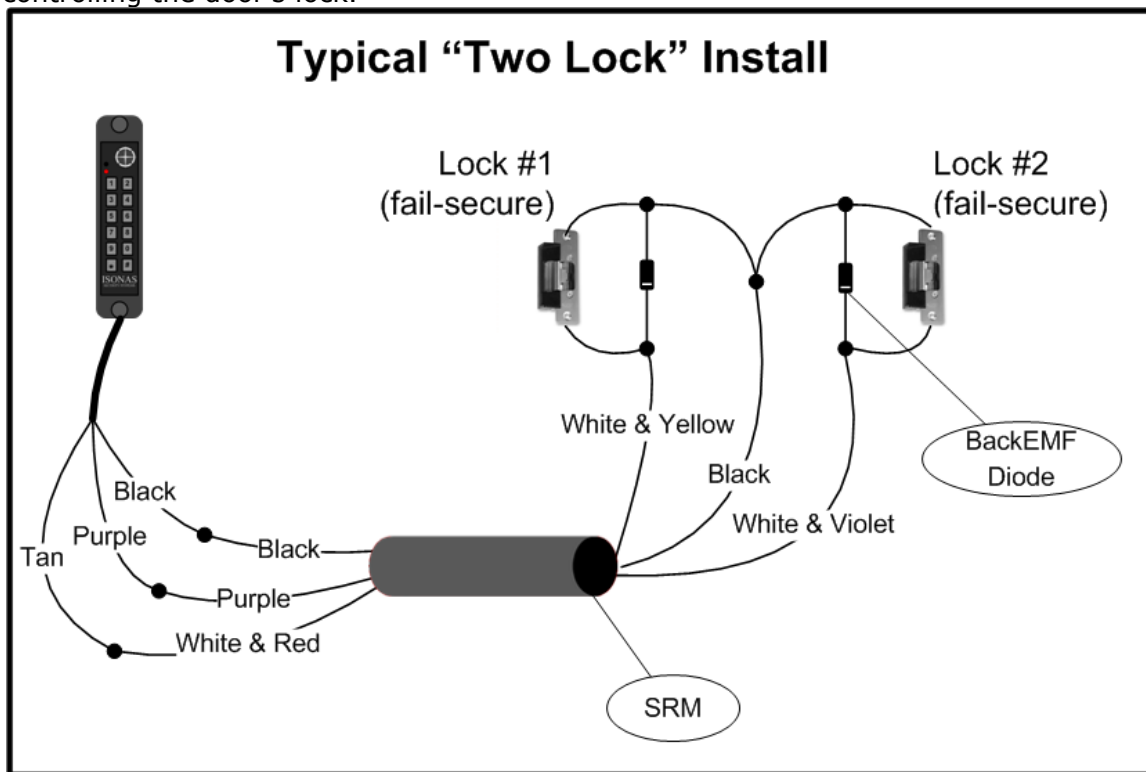

Figure 16

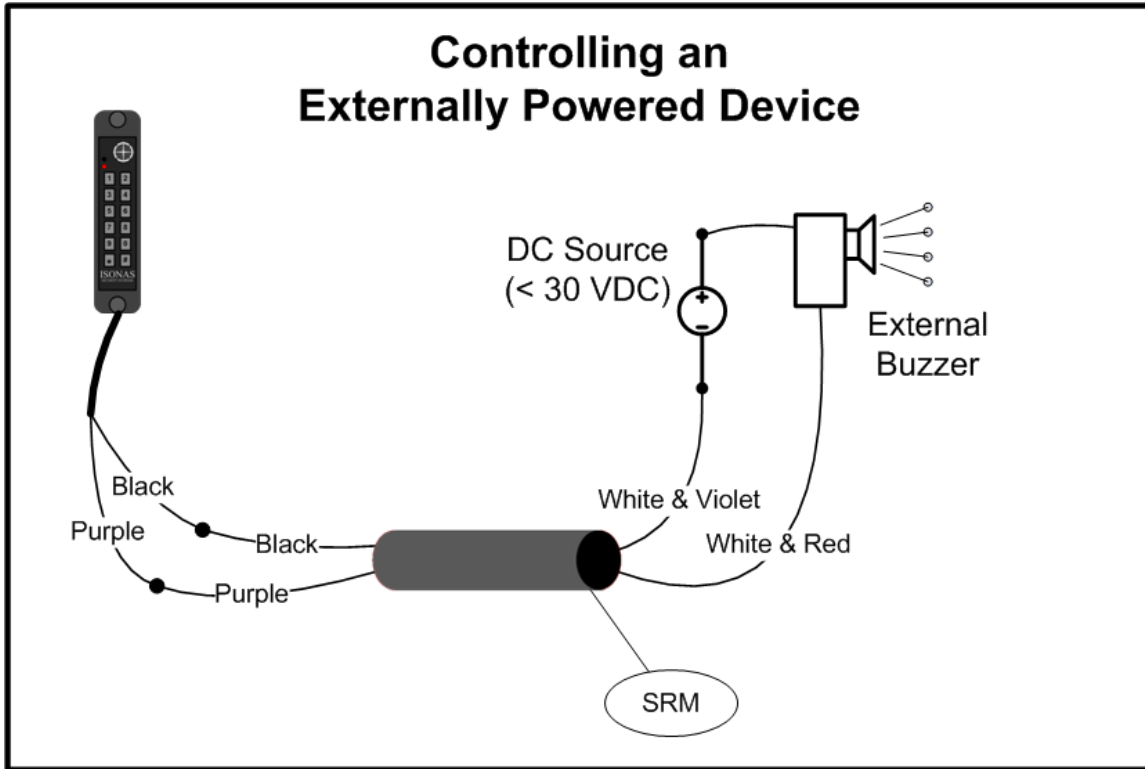

Figure 17

SRM's wiring color code

Color	Function
Purple	TTL input to SRM. Connected to the PowerNet pigtail's Purple or Brown conductor.
Black	Power Ground from PowerNet. Connects to Pigtail's Black conductor and other grounded connections
White / Red	SRM Relay Common contact
White / Violet	SRM Relay Open contact (when TTL is inactive)
White / Yellow	SRM Relay Closed contact (when TTL is inactive)

2.2.14: WIRING THE QUAD-SRM

The Quad Secondary Relay Module (QSRM) is available to allow a single PowerNet to control up to 4 locks.

The QSRM is an electronically controlled 4-way switch, that directs an input electrical signal to one-of-four outputs connections.

The QSRM is commonly used to control multiple doors on storage cabinets or computer racks.

Figure 18 shows a PowerNet and QSRM controlling four fail-secure locks.

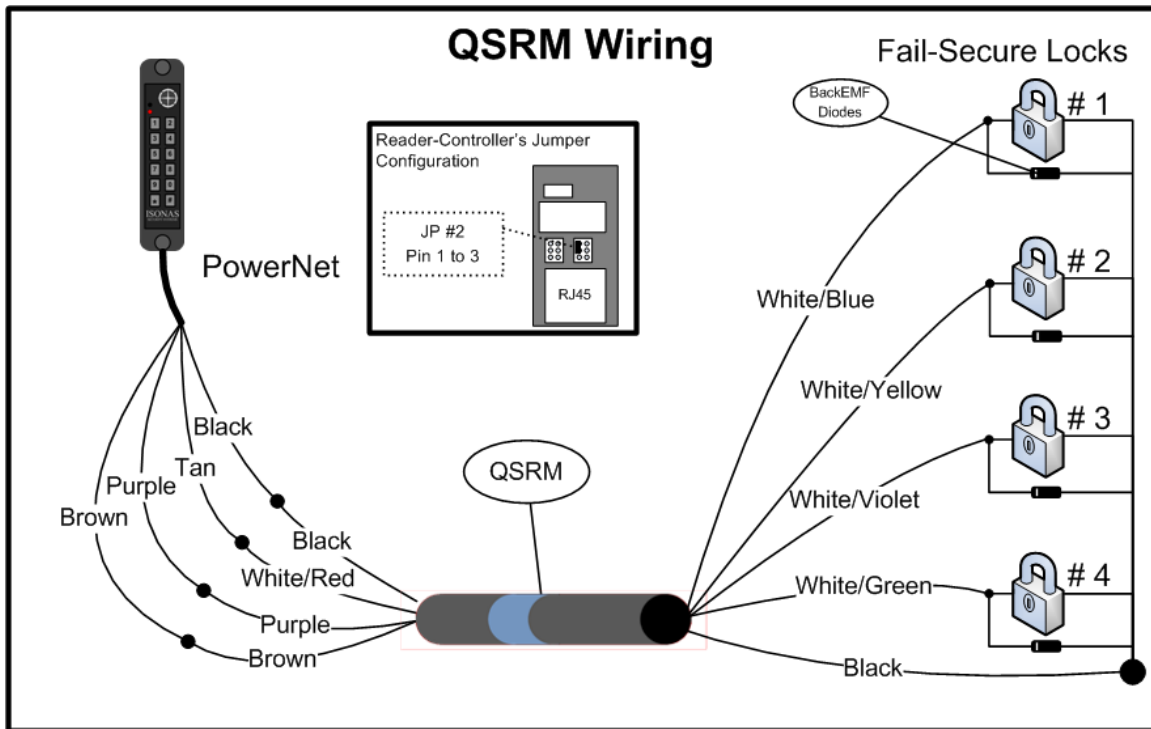

Figure 18

Note: The QSRM is easily identified by a blue stripe

QSRM's wiring color code

Color	Function
Purple	TTL input to SRM. Connected to the PowerNet pigtail's Purple conductor.
Brown	TTL input to SRM. Connected to the PowerNet pigtail's Brown conductor.
Red (PowerNet-side)	12 VDC Power
Black (PowerNet-side)	Ground (Power & Signal)
Black (x4) (Lock side)	Ground connection Connects to Pigtail's Black conductor and other grounded connections
White / Red	Electrical Signal Input Common contact
White / Blue	Connection's Output TTL1 = Active TTL2 = Inactive
White / Yellow	Connection's Output TTL1 = Inactive TTL2 = Active
White / Violet	Connection's Output TTL1 = Active TTL2 = Active
White / Green	Connection's Output TTL1 = Inactive TTL2 = Inactive

Example usages of the QSRM are shown in the Knowledge-base Article
KBA0015CabinetControl.PDF

2.2.15: MANAGING INDUCTIVE LOAD CHALLENGES

Most door latches use a **relay coil** that powers up and down to open and close the door. When this happens, electricity enters the connected circuit. This problem, known as **back EMF**, produces network interference that usually becomes more pronounced when the device is switched off.

Switching off a typical 12 VDC relay coil can produce a back EMF of 300 volts or more. If this relay is switched via an output, that voltage appears across the terminals of the output. The problem gets worse as switching voltage/current rises.

Figure 19 shows a solution. You can virtually eliminate back EMF by installing a **transient suppression device (diode)**. Each PowerNet is supplied with a diode assembly, which simplifies the installation process. A standard diode, from any electronic supply store, can also be used. Always check that the diode is correctly rated for the circuit voltage. For optimum performance, the diode should be installed at the lock or close to the lock. Standard diodes have a stripe-band marking on one side. That side of the diode should be connected to the "+" wire of the lock circuit.

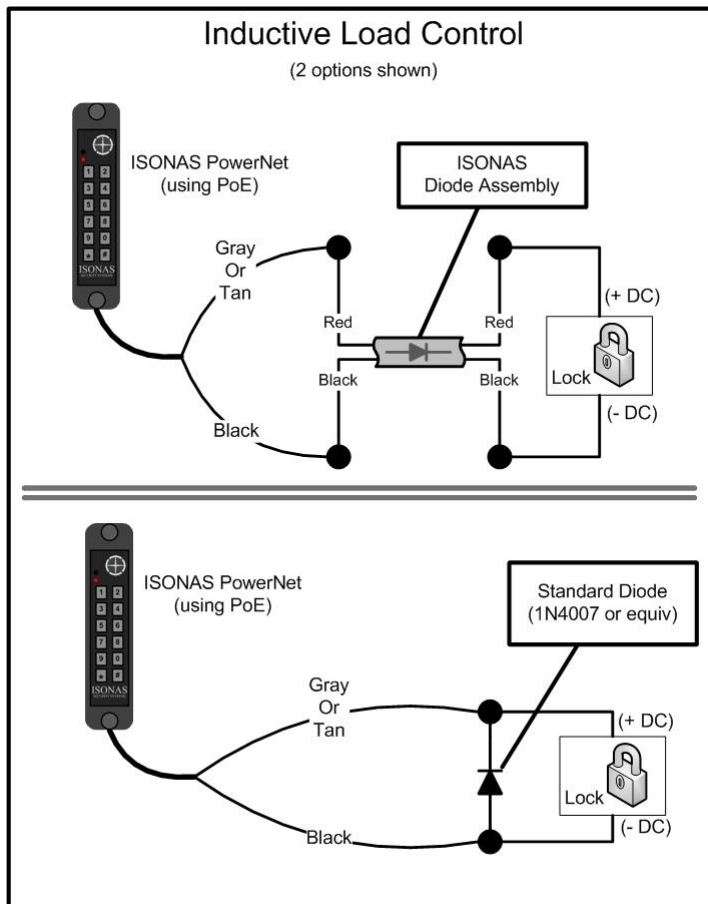

Figure 19

Protect the Digital Output

Which type of transient suppressor should you install? This depends mainly on the type of inductive load being switched. Some locks have Back EMF protection built into the lock itself.

For Back EMF in low-voltage DC applications, a 1N4007 diode will suffice.

However, for protection against other transient voltages (i.e. lightning), we recommend using a fast-switching transient voltage suppressor, such as a bipolar TranZorb.

2.2.16: MANAGING IN-RUSH CURRENT LOADS

Some **Magnetic Locks** with advanced quick-release circuitry will generate an initial surge of current when the lock is turned on. This surge of current can be 20 times greater than the lock's steady state current requirements. The lock control relay is rated for 1 amp of current. This in-rush current can greatly exceed that rating, and shorten the useful life of the reader-controller.

Any installation that is using **Magnetic Locks** that are equipped with a "quick-release feature" should have this in-rush protection installed.

Other devices who also create this in-rush current include incandescent light bulbs and "capacitive loads". A light bulb's cold resistance is close to 0 ohms, and a discharged capacitor is also a short-circuit when power is initially applied. Any installation which is controlling these types of devices should have the in-rush suppressor installed.

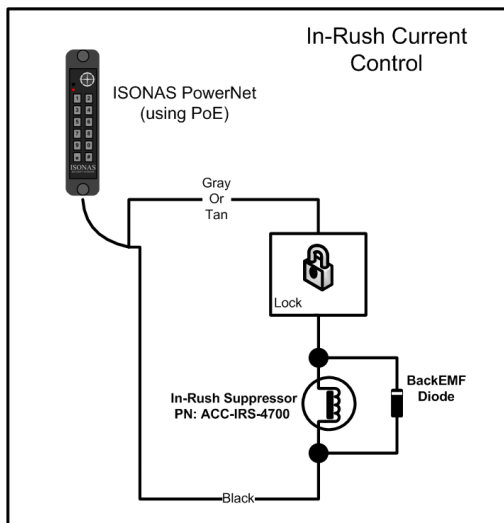

Figure 20a
(ACC-IRS-4700 w/two black wires)

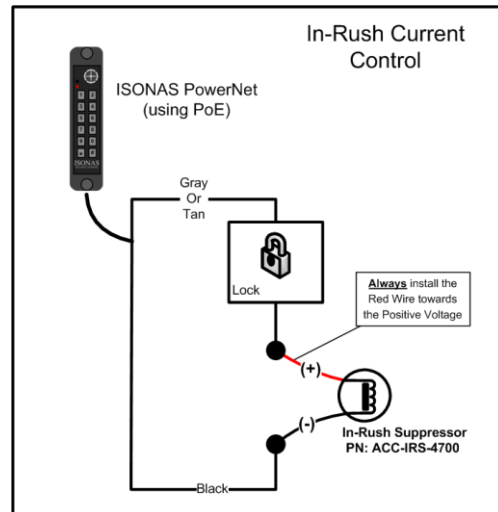

Figure 20b
(ACC-IRS-4700 w/red & black wires)

Figure 20a and 20b shows the solution to this. Installing an in-rush suppressor in the lock circuit will prevent any detrimental affects on the reader-controller.

2.3: CONFIGURATION EXAMPLES

2.3.1: PoE --- ELECTRIC STRIKE

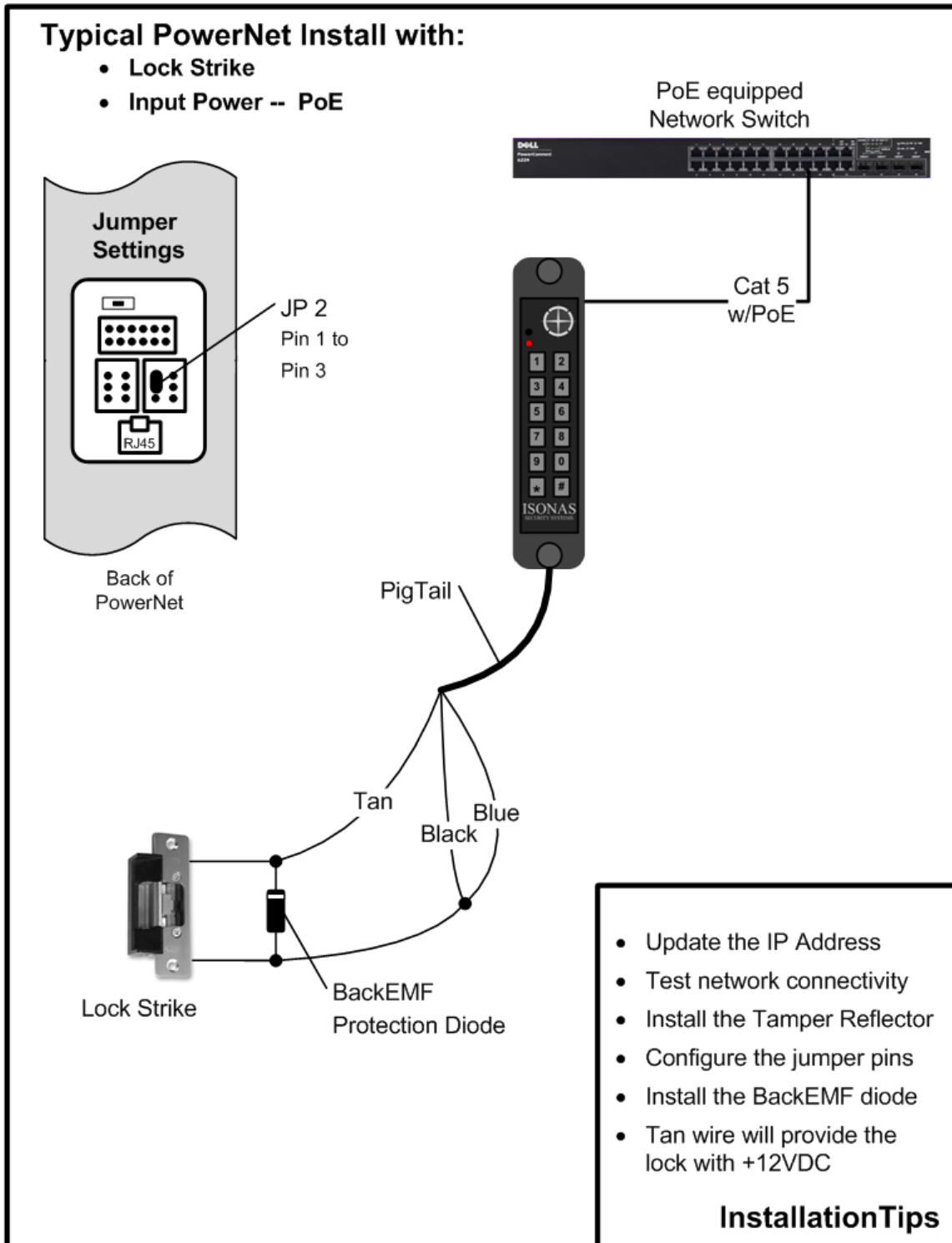

Figure 21

2.3.2: PoE --- EXTERNAL PWR FOR ELECTRIC STRIKE

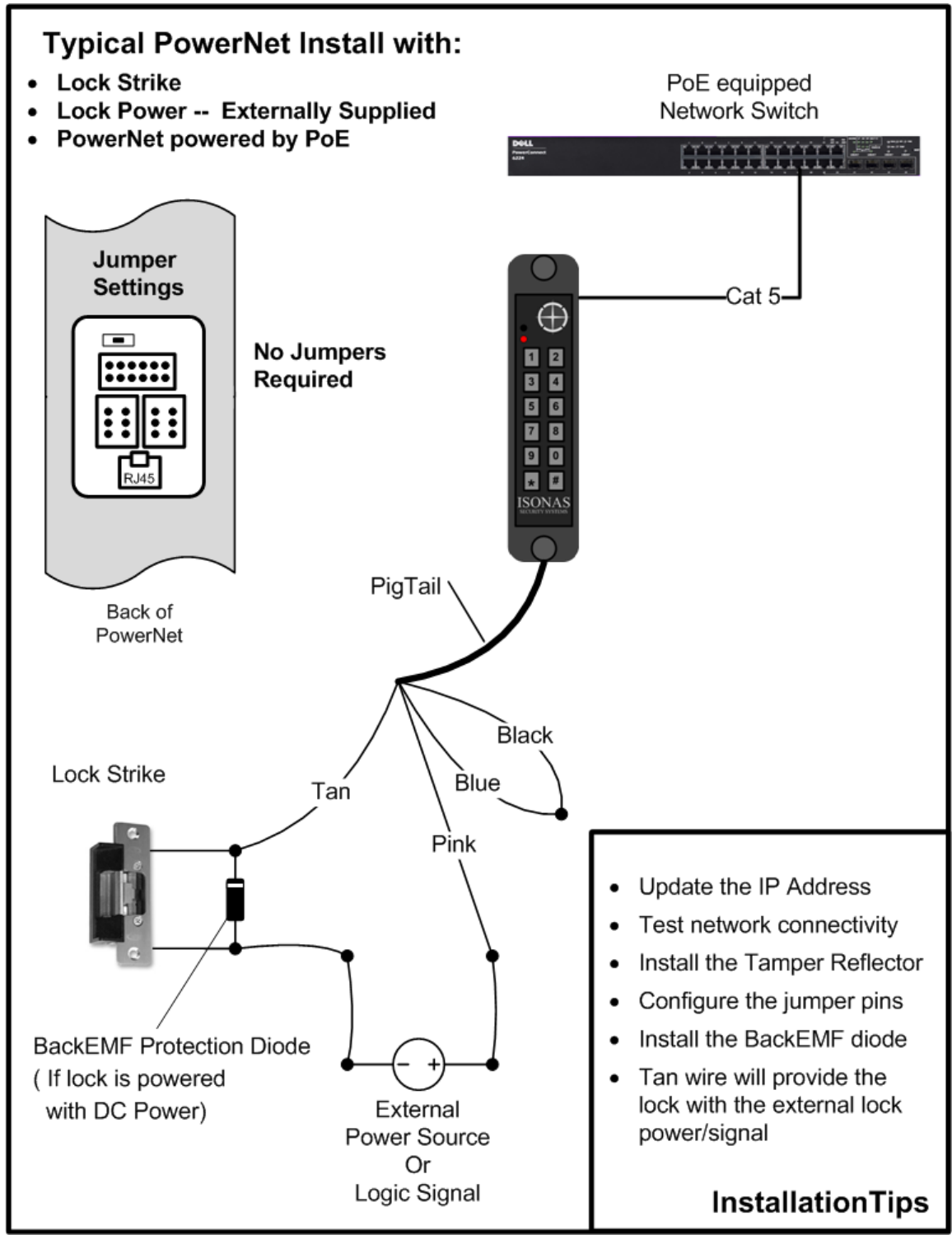

Figure 22

2.3.3: 12VDC – ELECTRIC STRIKE

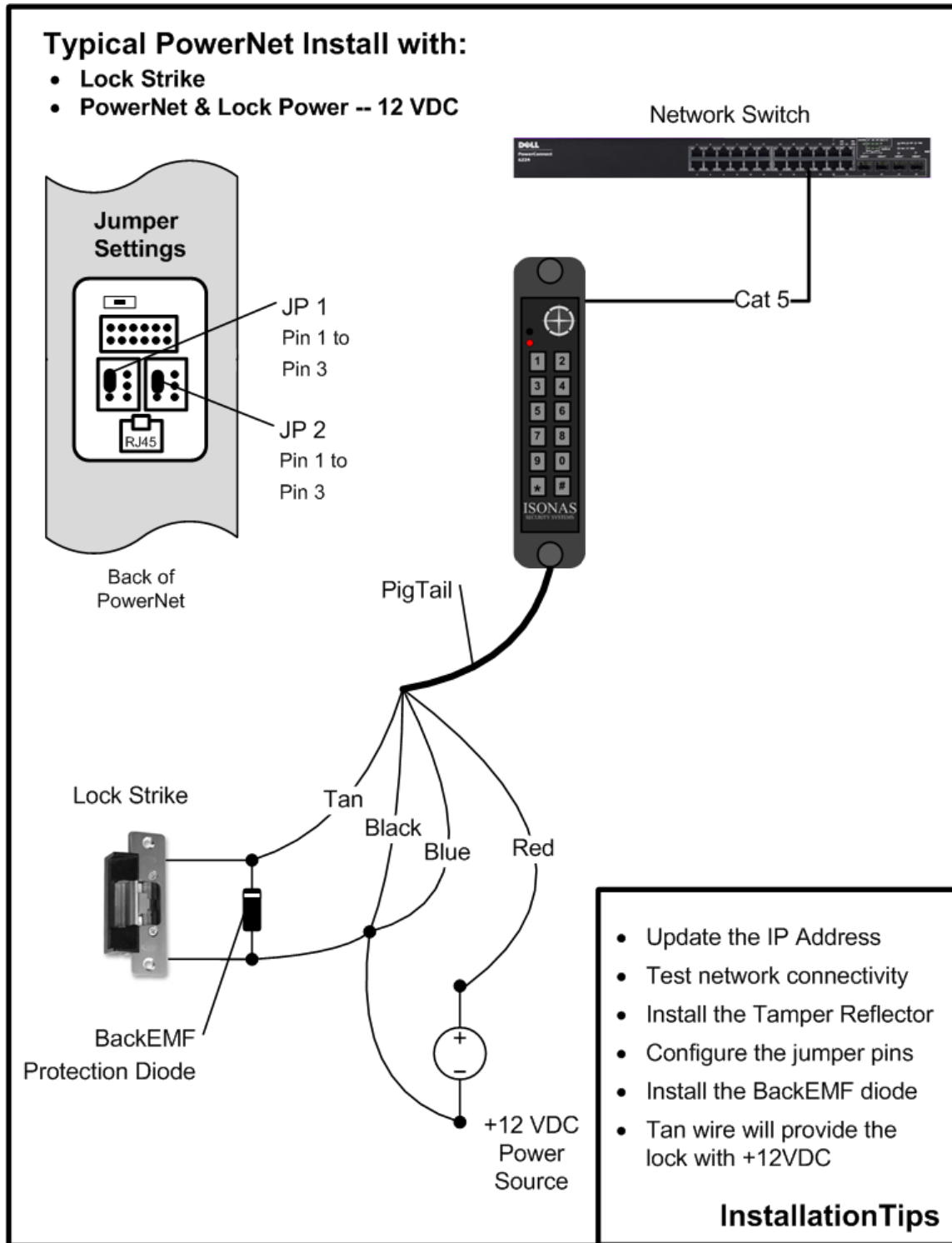

Figure 23

2.3.4: PoE --- MAGNETIC LOCK

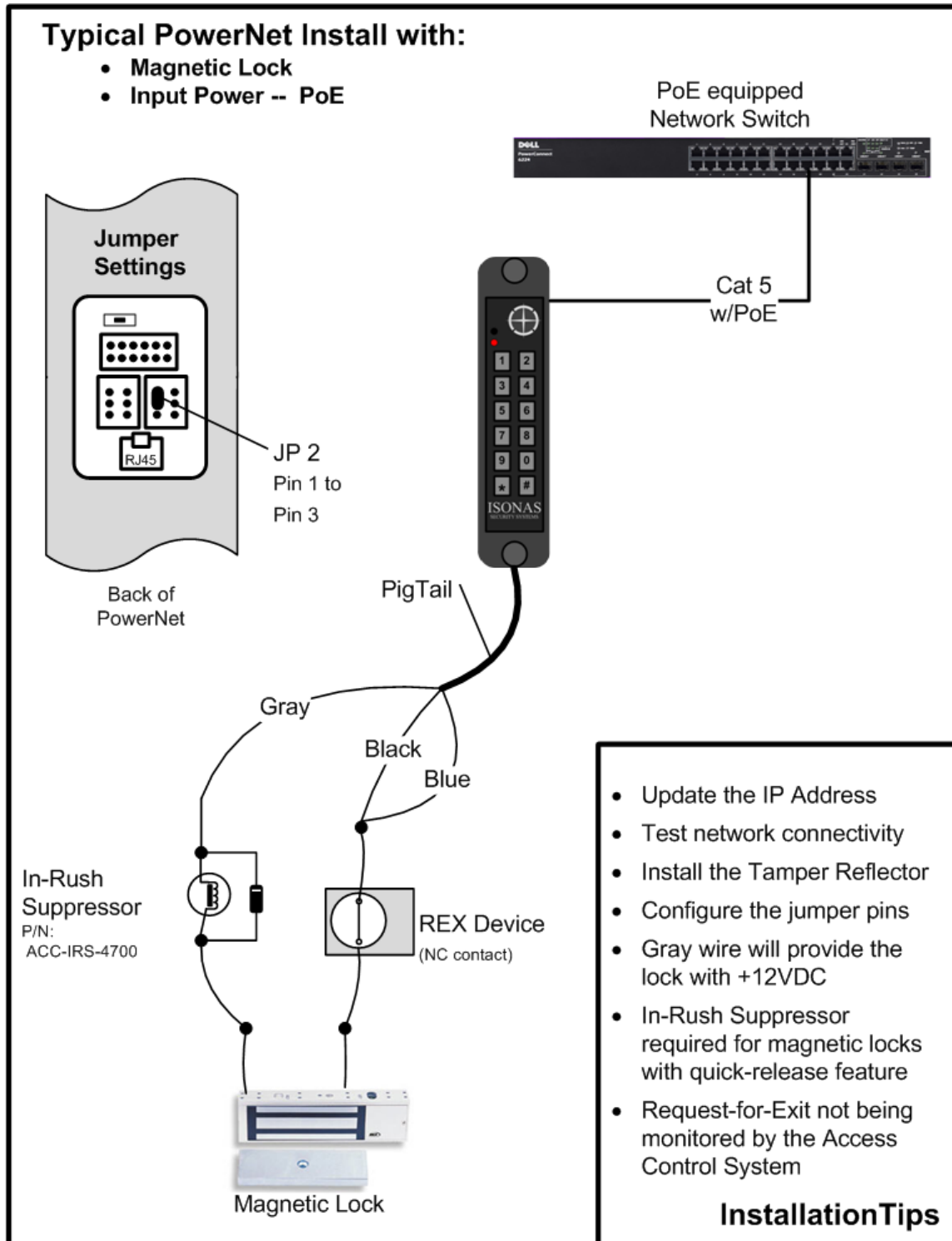

Figure 24

2.3.5: PoE --- MAGNETIC LOCK & PIR

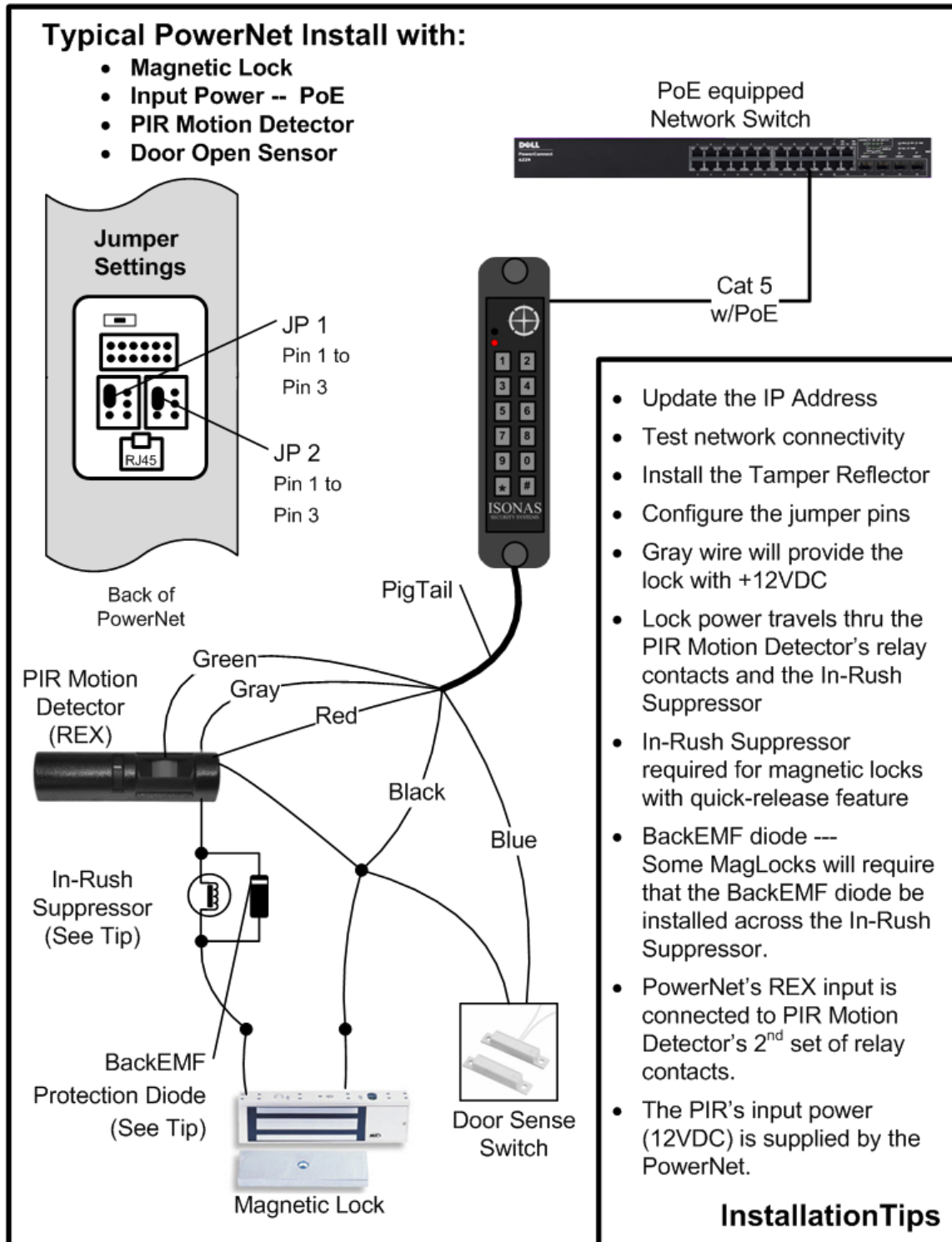

Figure 25

2.3.6: PoE --- MAGNETIC LOCK, EDK & PIR

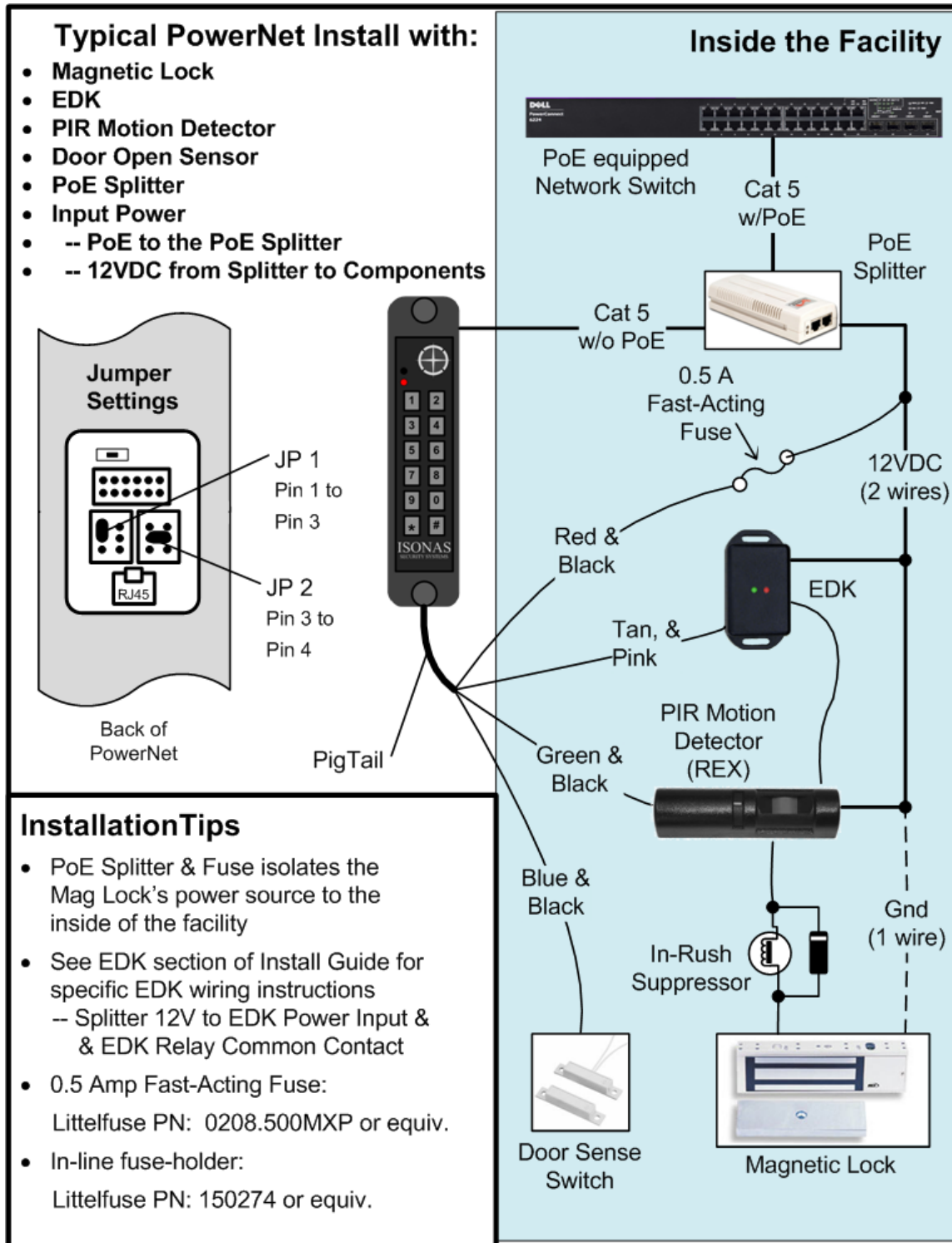

Figure 26

2.3.7: DUAL POWER SOURCES

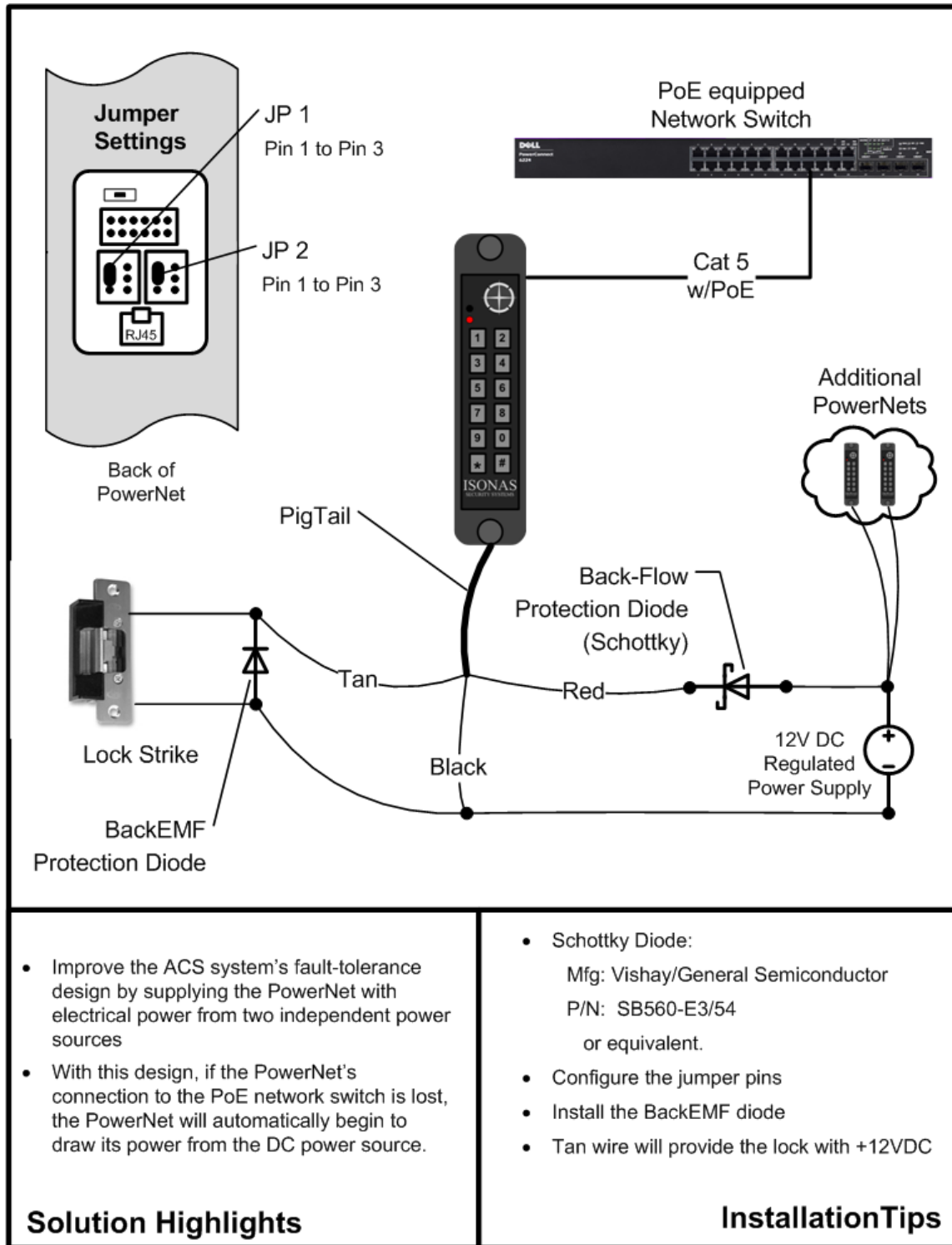

Figure 27

3: CONFIGURING THE READER-CONTROLLER'S COMMUNICATIONS

ISONAS Crystal software communicates to the Reader-controller units over the organization's data network.

3.1: ETHERNET-BASED TCP/IP READER-CONTROLLERS

There are many Ethernet network topology permutations, too many topologies to cover in this guide. Here are two common Ethernet configurations used by ISONAS customers:

- **Direct Crystal-Software to Readers:** This is the simplest type of network connection. ISONAS Crystal software runs on a server/workstation that is connected to an Ethernet network. All the Reader-controllers are also directly connected to this network.

Addressing: Each reader's assigned IP address is reachable from the server/workstation. For example, assume that you are installing three Reader-controllers. Two are located in your own Austin Texas office, and 1 is located in the company's Singapore office. Your networking staff gives you three IP addresses to use. 205.155.45.130 and 205.155.45.131 for the Readers that are located in your office. 205.172.37.130 for the reader located in the Singapore office. As long as the network is configured so your workstation can reach all three reader-controllers, there is no difference in configuring or using the three readers.

Here are a couple guidelines to follow to assure that your network's configuration will support the ISONAS access system.

1. The ISONAS reader-controller is a standard "network appliance". Standard TCP/IP rules apply.
2. For many installations, each reader-controller is assigned a static IP address. Typically, the network administrator will define what IP address to use.
3. The reader-controller's IP Address should be a valid IP address for the network-subnet that the reader-controller is physically connected to.
4. If the reader-controller's IP Address must be changed, then the ISONAS tool "Plug and Play" can be used to reset the IP Address. See the Crystal Matrix Software Users Guide for more details on using this tool. Note: Plug and Play requires that the workstation running the Plug and Play application and the reader-controller be physically connected to the same network subnet.
5. The host's IP Address should be a valid IP address for the network-subnet that the host is physically connected to.
6. If the host and reader-controller are on different subnets, then network routers must be in-place to enable TCP/IP communications between the two subnets.
7. One definition of a "Network subnet" is:
 - The set of network connections that can communicate with each other without having to go thru a network router.

- **Using Port Forwarding to reach the Readers.** This is common on networks where the available number of IP addresses is limited. It can also be used when the ISONAS software must communicate with Reader-controllers on another site that is behind a network firewall.

As in the first topology, ISONAS Crystal software runs on a server/workstation that is connected to a Ethernet network. The readers are connected to a network, but because of the design of the network, the readers can not be directly reached from the workstation/server. A router is between the server/workstation and the readers. The router is configured to implement Port Forwarding. The router will intercept and redirect the IP communications to enable the server/workstation to communicate with the Readers. This configuration allows you to connect many Readers without consuming the primary network's IP address allotment.

Addressing: Each Reader-unit is assigned an IP address with its local network (not the server/workstation network). example, assume the reader's network uses IP addresses in 192.168.10.2 thru 192.168.10.254. In this assume that the Server/workstation has an IP 84.117.31.158.

Port Addressing: (please refer **28**) Port forwarding is a Routers, when using this configuration the ISONAS does not need the IP address reader-controller, it just needs number associated with each however, the software does address of the *Router*.

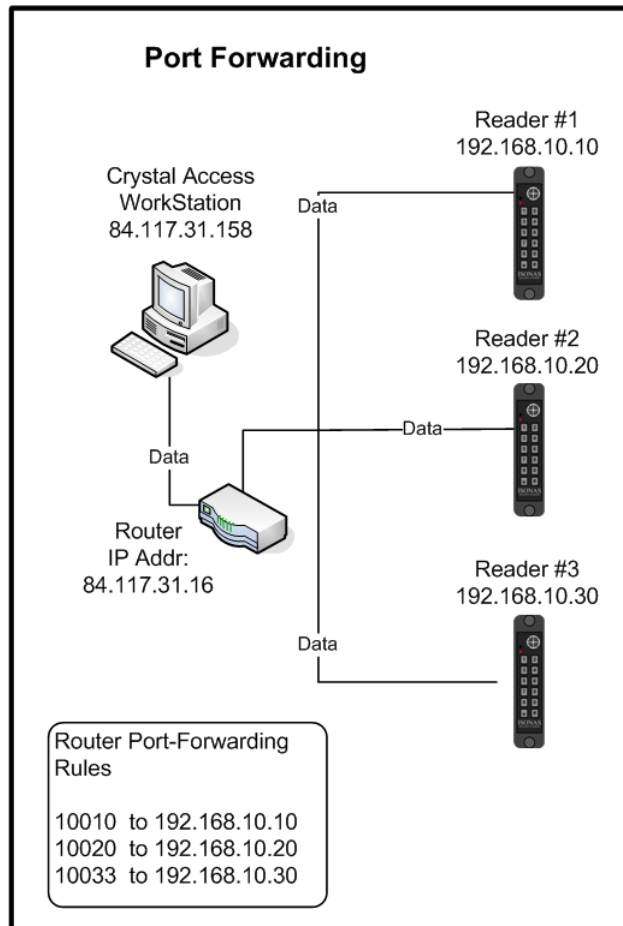

controller compatible
For local the range of example, address of to **Figure** function of software of each the Port reader; need the IP

Figure

28

Configuring the ISONAS software is easy, you simply define an 'IP address' with the address of the Router (in this example it is 84.117.31.16), then each reader is given a unique Port number assignment under that server.

Here is an example of the ISONAS Network screen for the above configuration:

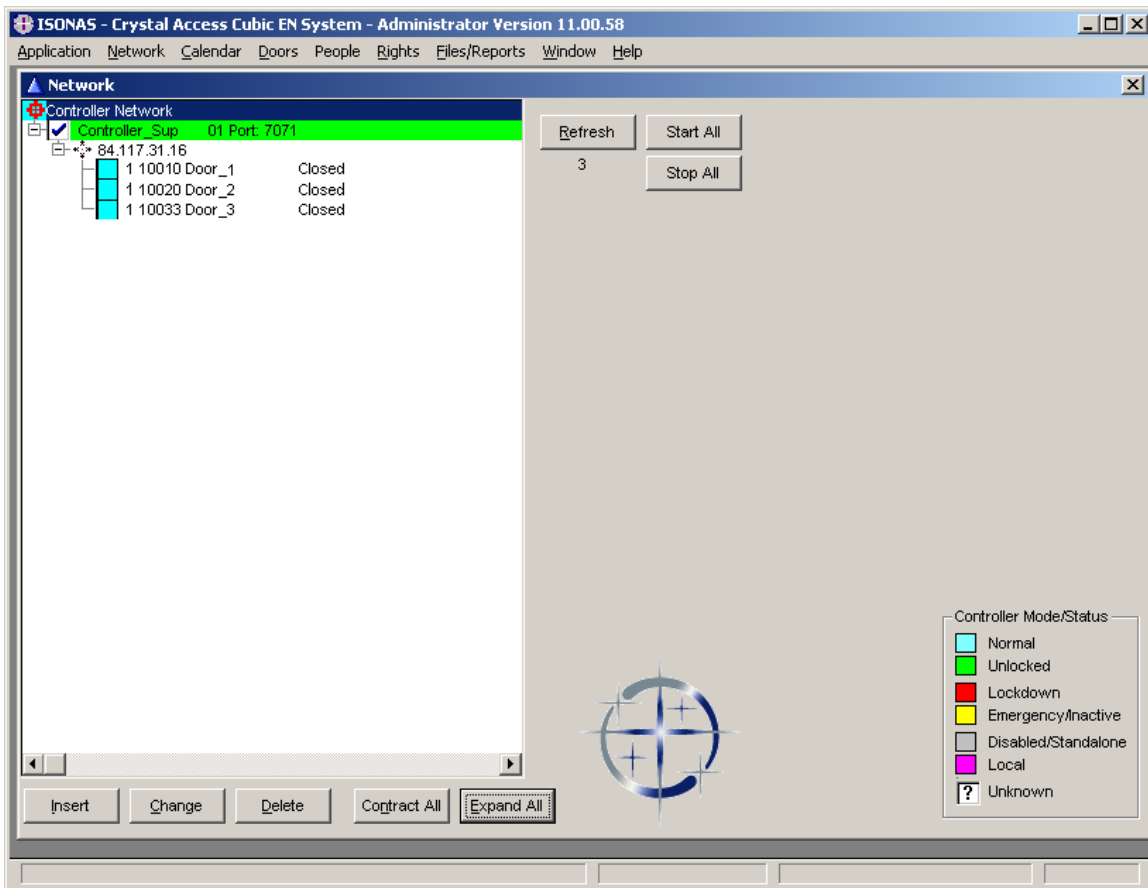

Port Forwarding requires steps outside of the ISONAS software; you must configure your Router to “forward” each port number to exactly one reader. This configuration is specific to the Router that you purchase and will be defined in the vendor’s documentation. Typically the configuration is labeled “port forwarding”; however it is sometimes referred to as “gaming options.”

When using Port Addressing, it will also be necessary to configure each of the Reader-controllers to have the proper IP address and to use the correct Port number. Changing the IP addresses and port number for the reader-controller is easily accomplished using the ISONAS Plug and Play application

Note:

Port Forwarding requires configuration of the network router. Please reference the router’s manual for instructions on configuring the router to support this feature.

3.2: SECURING MESSAGES ON YOUR NETWORK

You can configure ISONAS Readers and software to *secure each and every message* to and from the Reader using **Advanced Encryption Standard (AES)**.

When you enable AES in both an ISONAS Reader-controller and the Crystal software, every message to and from that Reader-controller is encrypted. Therefore, anyone who manages to hack into your data network would still face a daunting task to decrypt the actual messages to the Reader-controllers. This is a significant ISONAS advantage in protecting Reader-controllers from hackers.

For more information:

Web: www.isonas.com **E-mail:** sales@isonas.com

Tel: 800-581-0083 (toll-free) or 303-567-6516 (CO)

Fax: 303-567-6991

ISONAS Headquarters:

4720 Walnut Street, Suite 200, Boulder, Colorado 80301 USA