

| EVOLUTION / MODIFICATION CHANGE |     |                           |             |                           |   |                            |
|---------------------------------|-----|---------------------------|-------------|---------------------------|---|----------------------------|
| DRAWN BY / DESSINE PAR          | LCL | DATE / DATE               | 10-Nov-2023 | STATE / ETAT              | DATE ( DD/MM/YYYY ) / DATE ( JJ/MM/AAAA ) | DRAWN BY / DESSINE PAR     |
| MASS - MASSE                    |     | 0,000 kg                  |             | Checked by / VERIFIER PAR | LCL                                       | Approved by / APPROUVE PAR |
| MATERIAL - MATIERE              |     | Officiel                  |             | Checked by / VERIFIER PAR | LCL                                       | Approved by / APPROUVE PAR |
| PROTECT. FINISH - REVETEMENT    |     | Z NAUTIC GROUP            |             | Checked by / VERIFIER PAR | LCL                                       | Approved by / APPROUVE PAR |
| TOLERANCES                      |     | ISO 2758 CI               |             | ASSEMBLY / ENSEMBLE       | NOMAD 3.9                                 |                            |
| ALL DIMENSIONS IN MILLIMETERS   |     | DIMENSIONS EN MILLIMETRES |             | ENSEMBLE EQUIPE           |   |                            |
| SIZE / FORMAT                   | A3  | SCALE / ECHELLE           | 0,040       | PART NUMBER / REFERENCE   |   | 615835                     |
|                                 |     |                           |             |                           |   | REV -                      |

his drawing is the property of Z NAUTIC. it must not be reproduced or transmitted without the prior written permission of Z NAUTIC. Ce plan est la propriété de Z NAUTIC. Il ne peut être reproduit ou communiqué sans l'autorisation écrite préalable de Z NAUTIC. CAD Drawing - DO NOT MODIFY by hand / Plan CAO - NE PAS MODIFIER manuellement

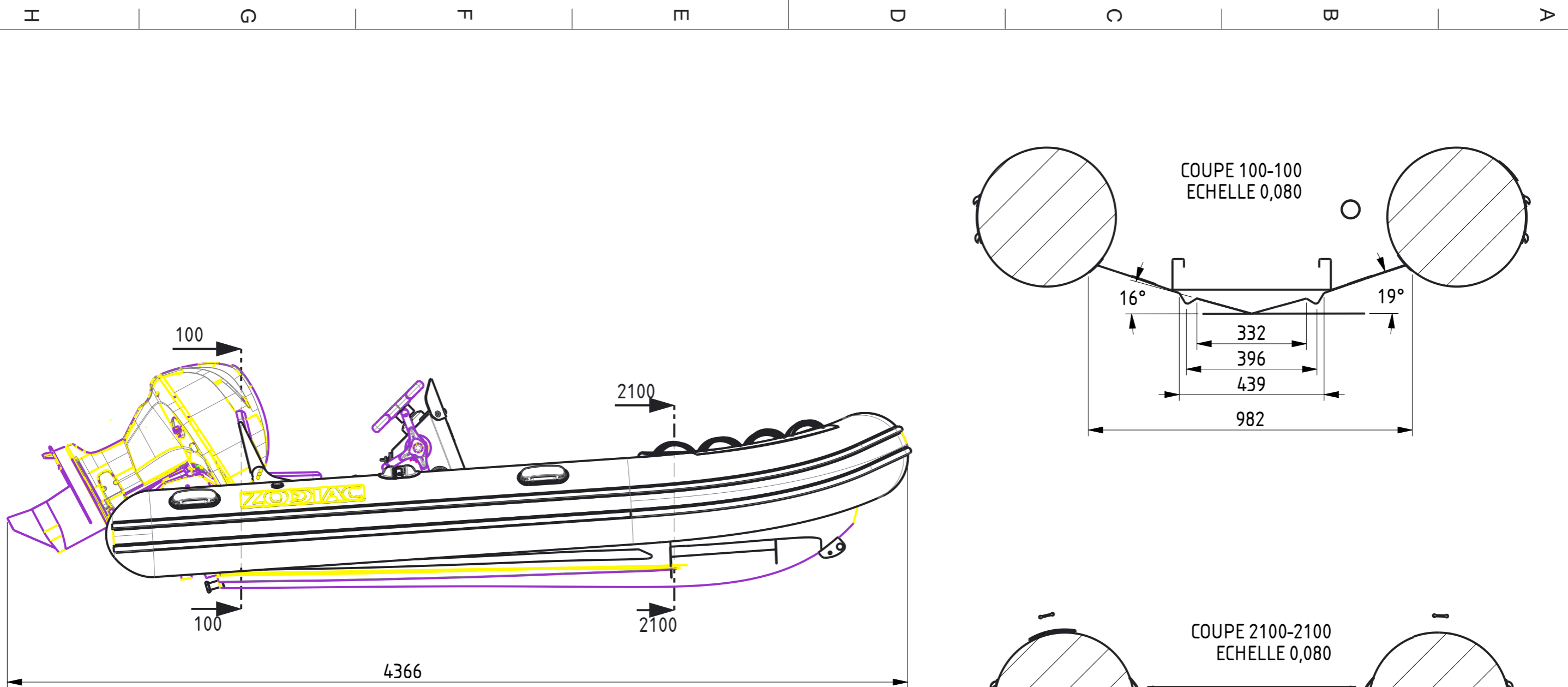

| EVOLUTION / MODIFICATION CHANGE                            |          |                    |             |                          |  |  |
|--|----------|--------------------|-------------|--------------------------|--|--|
| DRAWN BY<br>DESSINE PAR                                    | LCL      | DATE<br>DATE       | 10-Nov-2023 | STATE<br>ETAT            | DATE ( DD/MM/YYYY)<br>DATE ( JJ/MM/AAAA )                        | 10-Nov-2023  |
| MASS - MASSE   | 0,000 kg | MATERIAL - MATIERE |             | Official                 | 46 Avenue Gustave Eiffel<br>33600 PESSAC<br>Tel : 09-67-80-71-86 | R & D PESSAC   |
| PROTECT. FINISH - REVETEMENT                               |          | TOLERANCES         | ISO 2768CI  | ASSEMBLY<br>ENSEMBLE     | NOMAD 3.9  | 46 Avenue Gustave Eiffel<br>33600 PESSAC<br>Tel : 09-67-80-71-86   |
| ALL DIMENSIONS IN MILLIMETERS<br>DIMENSIONS EN MILLIMETRES |          | SIZE<br>FORMAT     | A3          | SCALE<br>ECHELLE         | 0,050  | his drawing is the property of Z NAUTIC.<br>it must not be reproduced or transmitted without the prior written permission of Z NAUTIC.<br>Ce plan est la propriété de Z NAUTIC.<br>Il ne peut être reproduit ou communiqué sans l'autorisation écrite préalable de Z NAUTIC<br>CAD Drawing - DO NOT MODIFY by hand / Plan CAO - NE PAS MODIFIER manuellement |
|  |          |                    |             | ENSEMBLE EQUIPE          |  |  |
|  |          |                    |             | PART NUMBER<br>REFERENCE |  | 615835   |
|  |          |                    |             | REV                      | -  |  |