

LINE CONDITIONERS

IREM *Ministatic/Steroguard*

Line conditioners

What are they?

Ministatic and Steroguard line conditioners have been designed to provide the highest level of protection to electrical appliances connected to distribution lines disturbed by sudden voltage variations, HF noises and spikes. Statistically, these phenomena represent more than 95% of electric anomalies that could be the cause of breakdowns and poor operation of any kind of appliance connected to distribution lines.

How are they made?

The standard models embody four different devices each one devoted to the compensation or attenuation of a specific electrical fault:

- a suppressor of voltage spikes
- a line filter
- a high attenuation isolating transformer
- a voltage regulator

The range

The range is made up of models with powers that vary from 0.5 to 830 kVA and use two different voltage regulation technologies:

- static switching technology for loads with single-phase absorption (up to 8 kVA) and three phase (up to 24 kVA)
- electrodynamic regulation technology via series transformer and variable autotransformer for loads with three-phase absorption (up to 830 kVA).

The two regulation technologies and the wide range allow the most suitable regulation system to be supplied to meet the specific needs of the various kinds of appliances.

TS..., TST... Series Ministatic electronic line conditioners

They have specific performances to power electronic appliances with medium to low powers that require a particularly high stabilisation speed such as: process and numerical controls, robotics, medical equipment, telecommunications and computers.

The range is made up of standard models with powers ranging from 0.5 to 24 kVA. Furthermore, because the manufacturing criteria make these conditioners highly versatile, on request, versions can be designed with customised specifications for the most varied applications.

TS series

The range is made up of single-phase models with powers ranging from 500 VA to 8 kVA. The noiseless operation, the compact size and fitness for use make them ideal for installation in offices and laboratories as well as in professional applications like automotive, chemical, food and telecommunications industry. It is a range that progressively extends following requests of customers with particular

needs regarding voltage, dimensions, protection degree, engineering and specific needs including, for example, the need to:

- connect single-phase 220, 230, 240 or 120 V loads to 500/400V lines without neutral.
- install these units inside electric switchgears or rack units

- * For TS600n and TS800n models only
- ** For TS600n and TS800n models only
- *** Standard fitting for TS600n and TS800n models, on request for TS.../GS and TS.../GSR
- **** For TS600n, TS800n and TS...GSR models

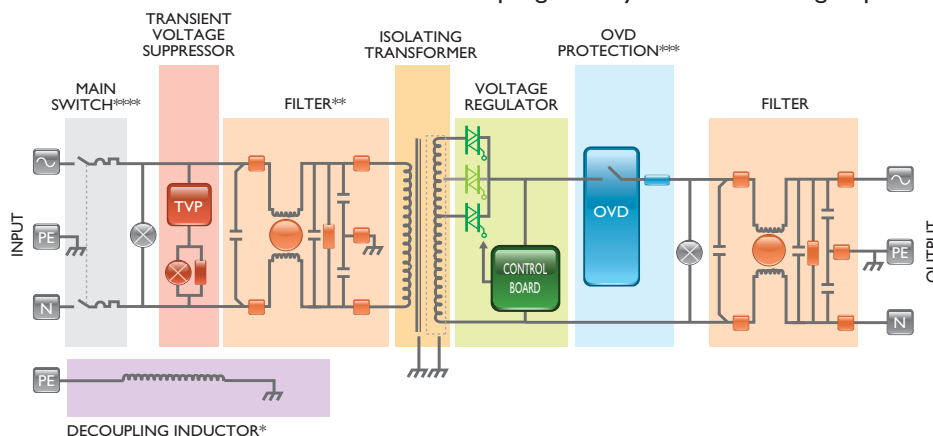

- have a range of “universal” appliances capable of delivering a 230V single-phase voltage powered by 440/400/220V 50 and 60 Hz three-phase distribution lines.

TST Series

This is made up of three-phase models with power from 6 to 24 kVA. It is particularly suitable for powering NC machine-tool equipment, automation plants and telecommunications systems. They are fitted with delta-star isolating transformer and create a “real neutral” and subsequently make it possible to have a single-phase 230V voltage using a three-phase 400V plant without neutral.

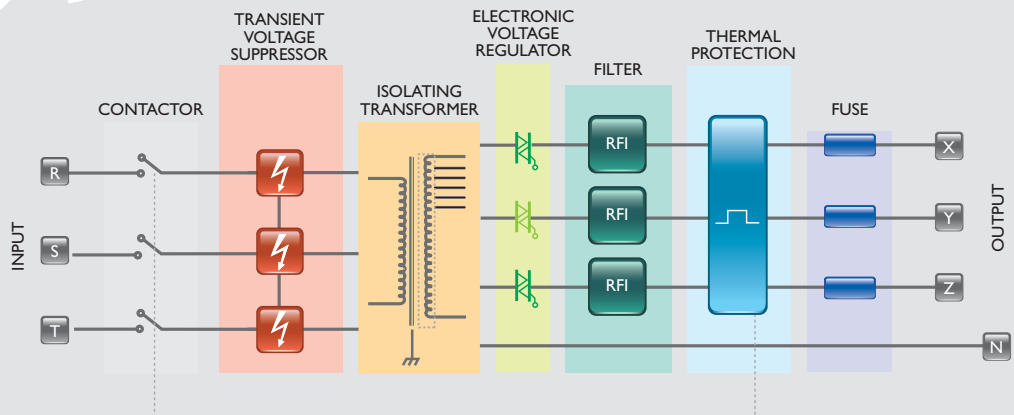

MINISTATIC electronic line conditioners fulfil their functions thanks to the combined performances of the different elements which constitute them.

Transient voltage suppressor

This device is intended to limit transverse and common mode spikes exceeding the input voltage peak value. Transient voltage protection can also be effective on spikes of atmospheric origin over 6kV.

RFI Filters

They attenuate high frequency transverse and common mode interferences over 300 kHz.

Isolating transformer

It is featured by low output impedance, insensitivity to load power factor, high attenuation and functional and dielectric isolation. The F thermal class transformer has a recessed concentric winding configuration to meet the impedance and power factor requirements. The double shielding allows a common mode attenuation higher than 110 dB up to 350 kHz and an insulation degree in compliance with relevant Standards. The creepage and clearance distances exceed 7 mm. The withstanding overvoltage at 50/60 Hz between primary and secondary exceeds 3750V. The isolation at fulmination pulse voltage is 8 kVolt.

Electronic Voltage Regulator

The electronic voltage regulator stabilises the voltage permitting to attain, under every load condition, $\pm 3\%$ output voltage accuracy with very high efficiency without generating any EMI interference.

Its main features are:

- response time lower than 2 ms/volt,
- insensitivity to load power factor,
- reduced dynamic impedance (0,5%),



- high overload capacity (7 to 15 x Inom).
- efficiency higher than 99%,
- “quasi-peak” output voltage sensing circuit which allows “data acquisition” in 10 ms and the compensation of wave form flattening caused by non linear loads,
- creepage and clearance distances exceeding 8 mm,
- mounting of power semiconductors with 2500 Volt internal insulation on isolated heatsinks.

Overvoltage protection (standard fitting on TS600n and TS800n - on request for TS.../GS and TS...GR models)

A safety device which cuts off the load when the output voltage exceeds +14% the nominal voltage for more than 0.4 seconds.

Decoupling inductor (on TS600 and TS800n only)

It is a high frequency non-saturable inductor. It can be used either as a decoupling inductor or as a filter for those interferences which could cause magnetic susceptibility.

Fittings:

- I** = Main breaker
- IM** = Thermal magnetic circuit breaker
- CF** = Frequency selector (50/60Hz)
- L** = “mains on” pilot lamps
- CT** = Voltage selector
- F** = Input fuse
- M** = Terminal board connection
- FF** = Ultra rapid output fuse
- BT** = Electronic voltage relay (on request)
- PT** = Thermal protection
- O** = OVD protection
- DT** = Decoupling inductor

Electronic line conditioners

Model	Power KVA	N. of phases	Input voltage V	Output voltage V	Rated current Amp	Standard fittings	Dimensions mm a x b x h	Net weight kg
TS50/GS	0,5	1	230/400/440±15%	230±3%	2,17	FF-CF-CT-M	380x315x216	21
TS75/GS	0,75	1	230/400/440±15%	230±3%	3,26	FF-CF-CT-M	380x315x216	28
TS100/GS	1	1	230/400/440±15%	230±3%	4,35	FF-CF-CT-M	380x360x260	39
TS200/GS	2	1	230/400/440±15%	230±3%	8,7	FF-CF-CT-M	400x460x295	49
TS400/GS	4	1	230/400/440±15%	230±3%	17,39	FF-CF-CT-M	400x460x295	60
TS50/GSR	0,5	1	230/400/440±15%	230±3%	2,17	I-L-F-FF-CF-CT-M	482x415x221	23
TS75/GSR	0,75	1	230/400/440±15%	230±3%	3,26	I-L-F-FF-CF-CT-M	482x415x221	30
TS100/GSR	1	1	230/400/440±15%	230±3%	4,35	I-L-F-FF-CF-CT-M	482x460x266	45
TS200/GSR	2	1	230/400/440±15%	230±3%	8,7	IM-L-FF-CF-CT-M	482x560x310	58
TS400/GSR	4	1	230/400/440±15%	230±3%	17,39	IM-L-FF-CF-CT-M	482x560x310	68
TS600n	6	1	230±20%	230±3%	26,09	IM-L-FF-M-O-DT	455x405x580	80
TS800n	8	1	230±20%	230±3%	34,78	IM-L-FF-M-O-DT	455x405x580	119
TS200/SC	2	1	500/400±20%	110±3%	18,18	FF-CT-M	460x300x315	46
TS300/SC	3	1	500/400±20%	110±3%	27,27	FF-CT-M	500x365x370	59
TS400/SC	4	1	500/400±20%	110±3%	36,36	FF-CT-M	535x365x442	74
TS50/1G	0,5	1	110 (-20+15)%	110±5%	4,55	F-FF-M	296x177x172	21
TS100/1G	1	1	110 (-20+15)%	110±5%	9,10	F-FF-M	296x177x172	44
TS200/1G	2	1	110 (-20+15)%	110±5%	18,18	F-FF-M	296x177x172	52
TS200/SD	2	1	110±15%	110±3%	18,18	FF-M	460x300x315	46
TS300/SD	3	1	110±15%	110±3%	27,27	FF-M	500x365x370	59
TS400/SD	4	1	110±15%	110±3%	36,36	FF-M	535x365x442	74
TST06N	6	3	400±15%	400+N±3%	8,7	I-L-FF-M-BT-PT	650x650x1300	165
TST12N	12	3	400±15%	400+N±3%	17,32	I-L-FF-M-BT-PT	650x650x1300	172
TST18N	18	3	400±15%	400+N±3%	26,00	I-L-FF-M-BT-PT	650x650x1800	295
TST24N	24	3	400±15%	400+N±3%	34,64	I-L-FF-M-BT-PT	650x650x1800	375

Other features

- Impedance: 0.3 to 11 Ohm depending on models
- No-load current: 40 to 700mA depending on models
- Total harmonic distortion: < 1%
- Operating temperature: -10°C +40°C
- Full load efficiency: >95%
- Audible noise: <40dB(A)

Conformity to Standards

Ministatic line conditioners conform to the requirements of the most recent Electro Magnetic Compatibility Standards, and particularly 2006/95/EC and 2004/108/EC.



Y...AC Series STEROGUARD electrodynamic line conditioners

They provide a maximum level of protection to high power appliances, with high electromagnetic susceptibility, connected to distribution lines disturbed by sudden voltage variations, high frequency interferences and voltage spikes.

The regulation system is made up exclusively of magnetic components capable of supporting loads with high inrush currents. The use of electronic components is limited to the control of the mains and of magnetic components stabilising the voltage. Thanks to these features, the electromechanical line conditioners stand apart for their high electromagnetic immunity and for the reliability characterised by a MTBF longer than 500,000 hours. They are, therefore, particularly suitable for powering radio-TV transmitters, telephone systems, radar systems, motors, compressors, pumps, medical equipment, machine tools and so on.

Their constructive features ensure that maintenance can be carried out even by technical staff with only a basic knowledge of electrical installations.

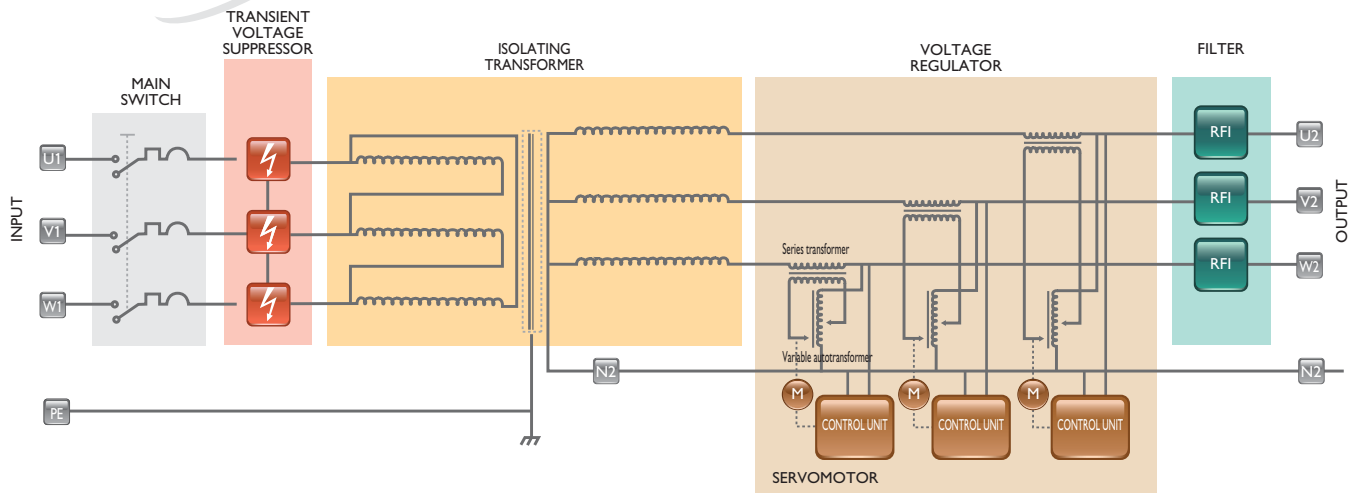

TVP transient voltage suppressors

The protection against transient overvoltages generated by atmospheric discharges or by switching process is carried out by type 2 (cat. C) surge arresters complying with EN 61643-11/VDE 0675, part 6-11 characterised by a nominal discharge current (8/20) I_n of 40 (or 60) kA, by a discharge current with I_{max} impulse of 50 (or 110) kA, a U_p protection level not greater than 1300 V and a response time t_A shorter than 25 ns.

Isolating transformer

This component, thanks to the electrostatic shield inserted between primary and secondary windings, ensures the galvanic separation and high attenuation of common mode noises. It is characterised by N delta-star configuration or F or N thermal class, low output impedance and insensitivity to the power factor. The insulation between primary and secondary, primary and shield, secondary and shield is greater than 3000 V during one minute.

Electrodynamic voltage regulator

It ensures the "true RMS" value of the voltage with $\pm 1\%$ output accuracy even in the presence of strong harmonic distortions.

The innovative control circuit, combined with the structural reliability of the electrodynamic stabilisation system, has the following characteristics:

- response time from 6 to 40ms/Volt, depending on the model
- overload capacity 10 times the nominal voltage for 10 milliseconds, 5 times for 6 seconds, twice for 60 seconds
- efficiency of 97-98%
- insensitivity to load power factor and load variations

- insensitivity to mains frequency variations, in $\pm 5\%$ range
- harmonic distortion introduced lower than 0.2% under any operating condition (virtually zero)
- internal impedance that varies, according to the models, from 0.52 to 0.0015 Ohm (it does not require a new sizing of the protections being irrelevant compared to the line impedance)
- sizing of the magnetic components aimed at limiting iron and copper losses in order to create a cooling system that only uses the natural convection. In fact, the use of fans requires maintenance, filter cleaning and replacement on average every two years.

RFI Filter

On the conditioners' output is installed a three phase filter for the suppression of electromagnetic interferences.

Operating temperature

Steroguard line conditioners are designed to operate properly with a maximum ambient temperature of $+40^{\circ}\text{C}$ under harsh conditions: continuous duty, full load, input voltage at minimum value.

Conformity to Standards

Steroguard line conditioners comply with the Standards contained in Directives: EMC and further amendments, Low Voltage 2006/95/EC and ETIC 2004/108/EC.

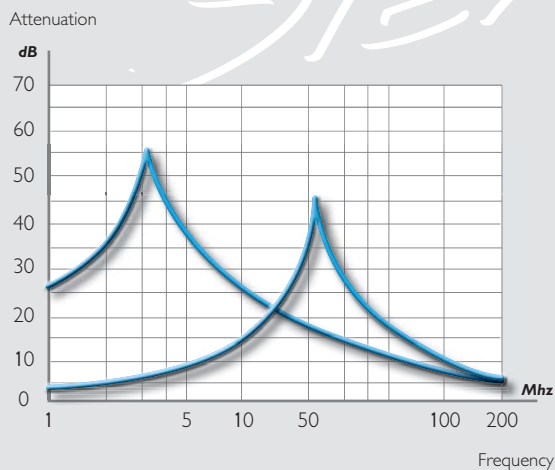

Steroguard



Three-phase + neutral electrodynamic line conditioners 230/400V 50/60Hz

Model	Rated power KVA	Rated current Amps	Voltage variation %	Response time ms/V	Accuracy ±%	Standard fittings	Degree of protection IP	Dimensions mm a x b x h	Net weight kg
Y306AC9	9	13	±25	12	±1	V, L, HF, PS, IT, I	21	1100x 650x1800	300
Y306AC12	12	17	±20	14					360
Y306AC15	15	22	±15	16					370
Y306AC24	24	35	±10	19					400
Y308AC15	15	22	±25	14	±1	V, L, HF, PS, IT, I	21	1100x 650x1800	360
Y308AC18	18	26	±20	16					380
Y308AC21	21	30	±15	18					400
Y310AC24	24	35	±25	14					490
Y310AC30	30	43	±20	16	±1	V, L, HF, PS, IT, I	21	1100x 650x1800	500
Y310AC45	45	65	±15	18					550
Y310AC60	60	87	±10	21					620
Y311AC33	33	48	±25	14					±1
Y311AC44	44	64	±20	16	300+430				
Y311AC63	63	91	±15	18	300+470				
Y311AC100	100	144	±10	21	300+610				
Y312AC45	45	65	±25	15	±1	V, L, HF, PS, IT, I	21	650x650x1800 + 650x650x1800	310+470
Y312AC60	60	87	±20	24					310+490
Y312AC90	90	130	±15	33					310+610
Y312AC120	120	173	±10	37					310+670
Y313AC55	55	79	±25	6	±1	V, L, HF, PS, IT, I	21	1100x650x1800 + 650x650x1800	460+480
Y313AC75	75	108	±20	6					460+535
Y313AC110	110	159	±15	7					460+645
Y313AC170	170	245	±10	11					460+755
Y314AC75	75	108	±25	11	±1	V, L, HF, PS, IT, I	21	1100x650x1800 + 1100x650x1800	570+660
Y314AC100	100	145	±20	12					570+670
Y314AC155	155	224	±15	14					570+890
Y314AC235	235	339	±10	18					570+1050
Y316AC120	120	173	±25	11	±1	V, L, HF, PS, IT, I	21	1100x650x1800 + 1100x650x1800	670+820
Y316AC160	160	231	±20	12					670+910
Y316AC230	230	332	±15	14					670+1080
Y316AC310	310	447	±10	18					670+1260
Y317AC170	170	245	±25	16	±1	V, L, HF, PS, IT, I	21	1100X650X1800 + 1100X650X1800	750+1180
Y317AC230	230	332	±20	17					750+1340
Y317AC315	315	455	±15	20					750+1420
Y317AC480	480	694	±10	26					750+1780
Y318AC230	230	332	±25	12	±1	V, L, HF, PS, IT, I	21	1100X1100X1800 + 1100X1100X1800	1200+1580
Y318AC310	310	447	±20	13					1200+1640
Y318AC450	450	650	±15	15					1200+1850
Y318AC650	650	938	±10	19					1200+1890
Y319AC315	315	455	±25	17	±1	V, L, HF, PS, IT, I	21	1100X1100X1800 + 1100X1100X1800	1500+2170
Y319AC470	470	678	±20	19					1500+2220
Y319AC610	610	882	±15	22					1540+2270
Y319AC830	830	1198	±10	27					1540+2440

Standard fittings

- V** = Voltmeter
- L** = Pilot lamp
- HF** = HF filter
- PS** = Overvoltage protection
- IT** = Input isolating transformer
- I** = Input thermal magnetic circuit breaker

Optional fittings: automatic or manual bypass, soft-start, overload protection, phase sequence/failure relay, ammeter, frequency-meter, multi-task network analyzer, thermal relay, tropicalized control boards and so on.

IREM. Experience and Quality

IREM is a leading company in the manufacture of electromechanical and electronic equipment for the control of the mains power in the following sectors:

- **powering of discharge lamps for professional applications;**
- **protection of electric users against line disturbances;**
- **luminous flux regulation in lighting plants;**
- **power generation by micro hydroelectric plants.**



Since its foundation in 1947, IREM has gained wide recognition due to the reliability and innovative content of its high-tech products. A reliable company deserving the Oscar-Award. In 1992, in Los Angeles, **Mario Celso** - founder of IREM - was granted the "**Scientific-Technical Award**" by the Academy of Motion Picture Arts and Sciences.

Two production plants, a philosophy based on "quality upgrading" as the company's primary concern and direct export exceeding 50% of the global turnover are a warranty of continuity and development. Experience, quality and professional skill: these are the factors that permitted IREM to achieve in 1993 the certification of its quality system in compliance with **UNI EN ISO 9001** standard, a further confirmation of IREM commitment to constant improvement to ensure the maximum satisfaction of the customer and its capacity to guarantee:

- a constant quality standard
- precision and repeatability of all working processes
- dropping of acceptance control at the customer's plant
- identification and traceability of a product through the years.

In year 2000, IREM obtained the certification of its environment management system according to **UNI EN ISO 14001** standard. This certification is a firm demonstration of the company's will to protect the environment not just through its products, but also via precise patterns of behaviour

