



■ Features :

- Universal AC input / Full range
- AC input active surge current limiting
- High efficiency up to 92%
- Built-in 12V/0.1A auxiliary power
- Built-in active PFC function, PF>0.97
- Protections: Short circuit / Overload / Over voltage / Over temperature / Fan alarm
- Output voltage can be trimmed between 40 ~ 110% by 2 ~ 5.5VDC external control signal
- Output current can be trimmed between 40 ~ 110% by 2 ~ 5.5VDC external control signal
- Forced air cooling by built-in DC with fan speed control function
- High power density 9.44w/inch³
- 1U low profile 41mm
- DC OK Signal
- Built-in remote ON-OFF control
- Built-in remote sense function
- 3 years warranty



SPECIFICATION

| MODEL | | RSP-750-5 | RSP-750-12 | RSP-750-15 | RSP-750-24 | RSP-750-27 | RSP-750-48 | |
|-----------------------|---|--|--------------------------|--------------------------|-----------------------|------------|--------------|--|
| OUTPUT | DC VOLTAGE | 5V | 12V | 15V | 24V | 27V | 48V | |
| | RATED CURRENT | 100A | 62.5A | 50A | 31.3A | 27.8A | 15.7A | |
| | CURRENT RANGE | 0 ~ 100A | 0 ~ 62.5A | 0 ~ 50A | 0 ~ 31.3A | 0 ~ 27.8A | 0 ~ 15.7A | |
| | RATED POWER | 500W | 750W | 750W | 751.2W | 750.6W | 753.6W | |
| | RIPPLE & NOISE (max.) Note.2 | 150mVp-p | 150mVp-p | 150mVp-p | 150mVp-p | 150mVp-p | 150mVp-p | |
| | VOLTAGE ADJ. RANGE | 4.75 ~ 5.5V | 10 ~ 13.5V | 13.5 ~ 16.5V | 20 ~ 26.4V | 24 ~ 30V | 43 ~ 55V | |
| | VOLTAGE TOLERANCE Note.3 | ±2.0% | ±1.0% | ±1.0% | ±1.0% | ±1.0% | ±1.0% | |
| | LINE REGULATION | ±0.5% | ±0.5% | ±0.5% | ±0.5% | ±0.5% | ±0.5% | |
| | LOAD REGULATION | ±2.0% | ±0.5% | ±0.5% | ±0.5% | ±0.5% | ±0.5% | |
| | SETUP, RISE TIME | 1000ms, 50ms at full load | | | | | | |
| HOLD UP TIME (Typ.) | 16ms/230VAC | | 16ms/115VAC at full load | | | | | |
| INPUT | VOLTAGE RANGE Note.5 | 90 ~ 264VAC | | 127 ~ 370VDC | | | | |
| | FREQUENCY RANGE | 47 ~ 63Hz | | | | | | |
| | POWER FACTOR (Typ.) | 0.97/230VAC | | 0.98/115VAC at full load | | | | |
| | EFFICIENCY (Typ.) | 82% | 87% | 89% | 90.5% | 90.5% | 92% | |
| | AC CURRENT (Typ.) | 5V : 5.6A/115VAC | | 2.8A/230VAC | 12V~48V : 8.2A/115VAC | | 3.9A/230VAC | |
| | INRUSH CURRENT (Typ.) | 25A/115VAC | | 40A/230VAC | | | | |
| | LEAKAGE CURRENT | <2.0mA / 240VAC | | | | | | |
| PROTECTION | OVERLOAD | 105 ~ 125% rated output power Protection type : Constant current limiting, recovers automatically after fault condition is removed | | | | | | |
| | OVER VOLTAGE | 5.75 ~ 6.75V | 13.8 ~ 16.8V | 17 ~ 20.5V | 27.6 ~ 32.4V | 31 ~ 36.5V | 56.6 ~ 66.2V | |
| | OVER TEMPERATURE | 85°C ±5°C (TSW2) detect on heatsink of O/P diode; 80°C ±5°C (TSW1) detect on heatsink of power transistor Protection type : Shut down o/p voltage, recovers automatically after temperature goes down | | | | | | |
| FUNCTION | AUXILIARY POWER(AUX) | 12V @ 0.1A ; tolerance : ±10% | | | | | | |
| | REMOTE ON/OFF CONTROL Note.6 | Power on : short between on/off(pin13) & 12V-AUX(pin14) on CN50 Power off : open between on/off(pin13) & 12-AUX(pin14) on CN50 | | | | | | |
| | DC OK SIGNAL | The TTL signal out, PSU turn on = 0 ~ 1V ; PSU turn off = 3.3 ~ 5.6V | | | | | | |
| | OUTPUT VOLTAGE TRIM Note.6 | Adjustment of output voltage is possible between 40 ~ 110% by 2 ~ 5.5VDC external control signal | | | | | | |
| | OUTPUT CURRENT TRIM | Adjustment of output current is between 40 ~ 110% by 2 ~ 5.5VDC external control signal | | | | | | |
| ENVIRONMENT | WORKING TEMP. | -30 ~ +70°C (Refer to "Derating Curve") | | | | | | |
| | WORKING HUMIDITY | 20 ~ 90% RH non-condensing | | | | | | |
| | STORAGE TEMP., HUMIDITY | -40 ~ +85°C, 10 ~ 95% RH | | | | | | |
| | TEMP. COEFFICIENT | ±0.03%/°C (0 ~ 50°C) | | | | | | |
| | VIBRATION | 10 ~ 500Hz, 2G 10min./1cycle, 60min. each along X, Y, Z axes | | | | | | |
| SAFETY & EMC (Note 4) | SAFETY STANDARDS | UL60950-1, TUV EN60950-1 approved | | | | | | |
| | WITHSTAND VOLTAGE | I/P-O/P:3KVAC I/P-FG:2KVAC O/P-FG:0.5KVAC | | | | | | |
| | ISOLATION RESISTANCE | I/P-O/P, I/P-FG, O/P-FG:100M Ohms / 500VDC / 25°C / 70% RH | | | | | | |
| | EMC EMISSION | Compliance to EN55022 (CISPR22), EN61000-3-2,-3 | | | | | | |
| | EMC IMMUNITY | Compliance to EN61000-4-2,3,4,5,6,8,11, EN55024, EN61000-6-2, EN61204-3, heavy industry level, criteria A | | | | | | |
| OTHERS | MTBF | 120.8K hrs min. MIL-HDBK-217F (25°C) | | | | | | |
| | DIMENSION | 250*127*41mm (L*W*H) | | | | | | |
| | PACKING | 1.64Kg; 6pcs/10.8Kg/1.1CUFT | | | | | | |
| NOTE | <p>1. All parameters NOT specially mentioned are measured at 230VAC input, rated load and 25°C of ambient temperature.</p> <p>2. Ripple & noise are measured at 20MHz of bandwidth by using a 12" twisted pair-wire terminated with a 0.1uf & 47uf parallel capacitor.</p> <p>3. Tolerance : includes set up tolerance, line regulation and load regulation.</p> <p>4. The power supply is considered a component which will be installed into a final equipment. The final equipment must be re-confirmed that it still meets EMC directives. For guidance on how to perform these EMC tests, please refer to "EMI testing of component power supplies." (as available on http://www.meanwell.com)</p> <p>5. Derating may be needed under low input voltages. Please check the derating curve for more details.</p> <p>6. The power supply unit will have no output if the shorting connector is not assembled. It contains three shorting wires: one is from on/off(pin13) to 12V-AUX(pin14), two is from PC(pin7) to PO(pin8) and the other is from PV(pin5) to PS(pin6). Please refer to function manual for details.</p> <p>7. Please consult MEAN WELL for applications of more units connecting in parallel.</p> | | | | | | | |

Mechanical Specification

Case No.212A Unit:mm

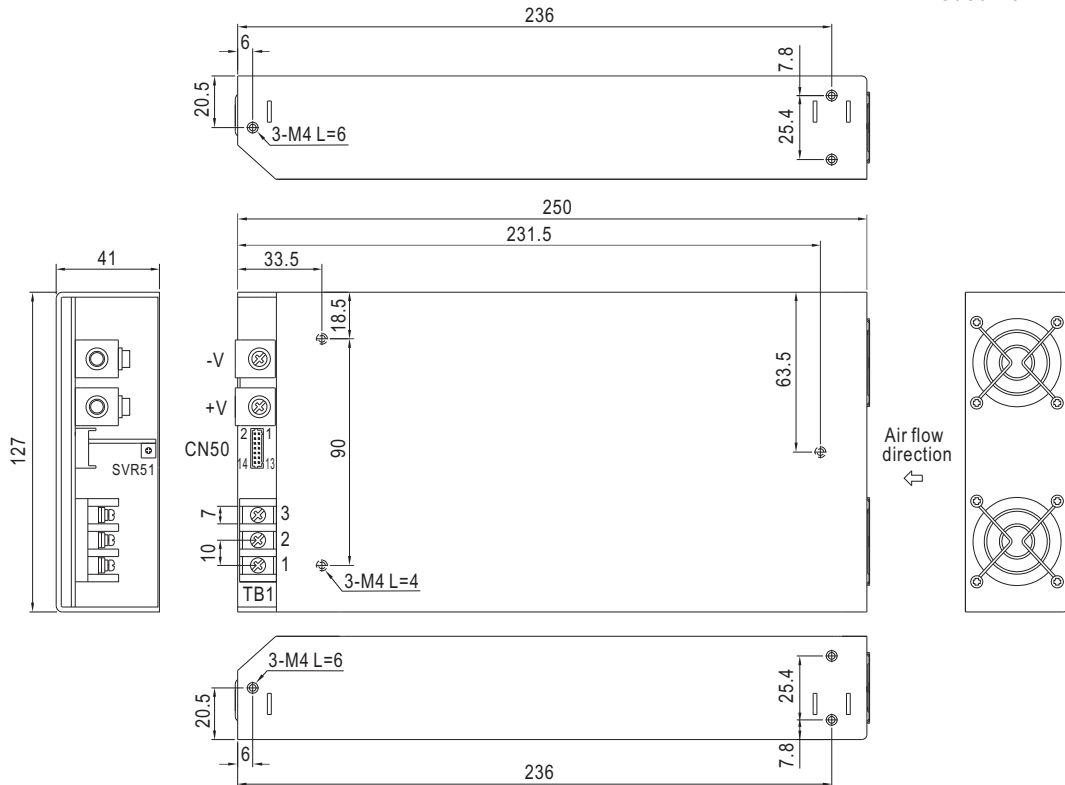

AC Input Terminal Pin No. Assignment

| Pin No. | Assignment |
|---------|------------|
| 1 | AC/N |
| 2 | AC/L |
| 3 | FG \perp |

Control Pin No. Assignment (CN50) : HRS DF11-14DP-2DS or equivalent

| Pin No. | Assignment | Pin No. | Assignment | Pin No. | Assignment | Mating Housing | Terminal |
|---------|------------|---------|------------|---------|------------|-----------------------------|-----------------------------|
| 1 | +S | 6 | PS | 12 | G-AUX | HRS DF11-14DS or equivalent | HRS DF11-**SC or equivalent |
| 2 | +VS | 7 | PC | 13 | ON/OFF | | |
| 3 | -S | 8 | PO | 14 | 12V-AUX | | |
| 4 | -VS | 9 | DC-OK | | | | |
| 5 | PV | 10,11 | GND | | | | |

Block Diagram

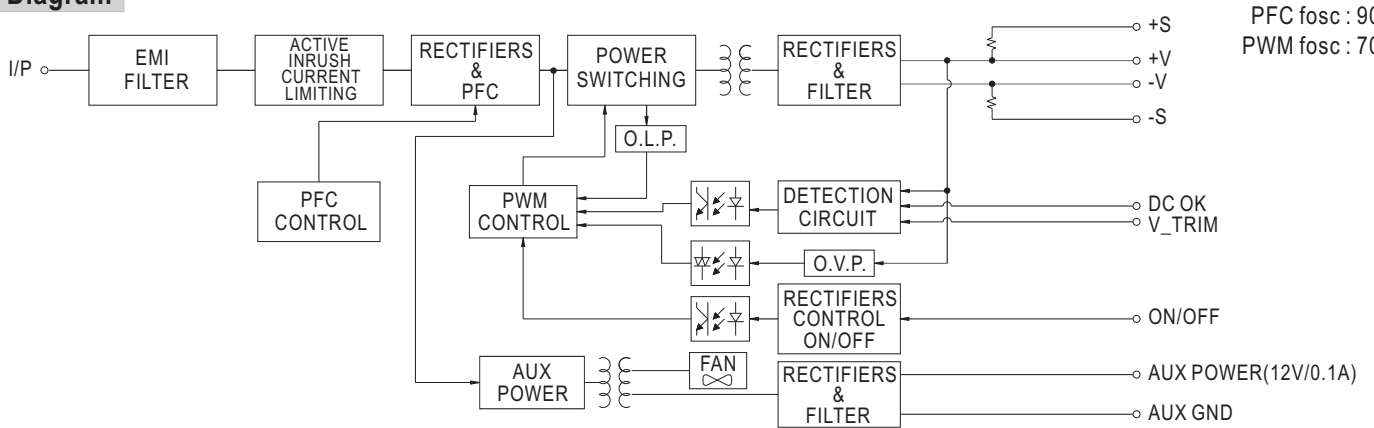

Derating Curve

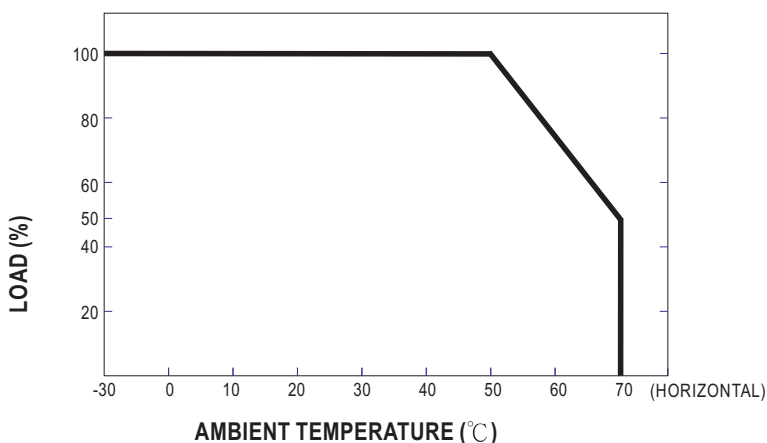

Static Characteristics

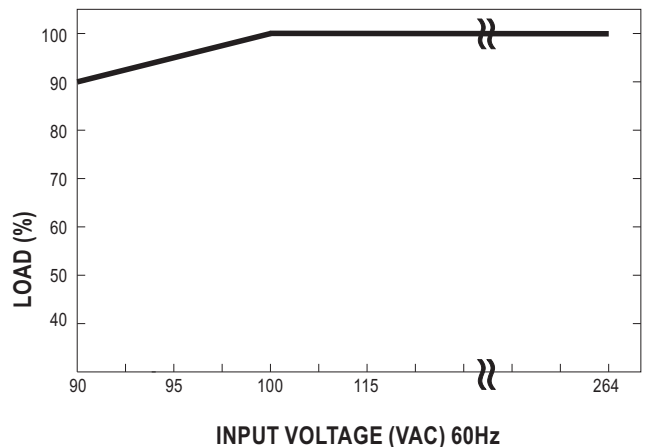

■ Function Description of CN50

| Pin No. | Function | Description |
|---------|----------|---|
| 1 | +S | Positive sensing. The +S signal should be connected to the positive terminal of the load. The +S and -S leads should be twisted in pair to minimize noise pick-up effect. The maximum line drop compensation is 0.5V. |
| 2 | +VS | +V Signal. The +VS should be connected to the +S to reduce the noise when "output voltage TRIM" function is in use. |
| 3 | -S | Negative sensing. The -S signal should be connected to the negative terminal of the load. The -S and +S leads should be twisted in pair to minimize noise pick-up effect. The maximum line drop compensation is 0.5V. |
| 4 | -VS | -V Signal. The -VS should be connected to the -S to reduce the noise when "output voltage TRIM" function is in use. |
| 5 | PV | Connect to external DC voltage source for output voltage trimming, referenced to pin 10,11 (GND). Output voltage can be trimmed between 40 ~ 110% of the rated output voltage. |
| 6 | PS | Short connecting between PV (pin5) and PS (pin6) if "output voltage TRIM" function is not used. |
| 7 | PC | Connect to external DC voltage source for output current trimming, referenced output current can be trimmed between 40 ~ 110% of the rated output current. Please refer to function manual for details. |
| 8 | PO | Short connecting between PC (pin7) and PO (pin8) if output current trim function is not used. |
| 9 | DC_OK | Open collector signal, referenced to pin10,11(GND). Low when PSU turns on. The maximum sink current is 10mA and the maximum external voltage is 5.6V. |
| 10,11 | GND | These pins connect to the negative terminal (-V). Return for DC_OK Signal output. |
| 12 | G-AUX | Auxiliary voltage output ground. The signal return is isolated from the output terminals (+V & -V). |
| 13 | ON/OFF | Turns the output on and off by electrical or dry contact between pin 13 (ON/OFF) and pin 14 (12V-AUX). Short: Power ON, Open: Power OFF. |
| 14 | 12V-AUX | Auxiliary voltage output, 10.8~13.2V, referenced to pin 12(G-AUX). The maximum load current is 0.1A. This output is not controlled by the "remote ON/OFF control". |

■ Function Manual

1. "Remote ON/OFF" and "Output voltage trim" and "Output current trim" functions are not used.

- (1) The power supply unit will have no output if the shorting connector (accessory comes along with the PSU) is not assembled. It contains three shorting wires : one is from ON/OFF (pin13) to 12V-AUX (pin14), two is from PV(pin5) to PS (pin6) and the other is from PC (pin7) to PO (pin8).
- (2) Factory setting is shorted as Fig1.1

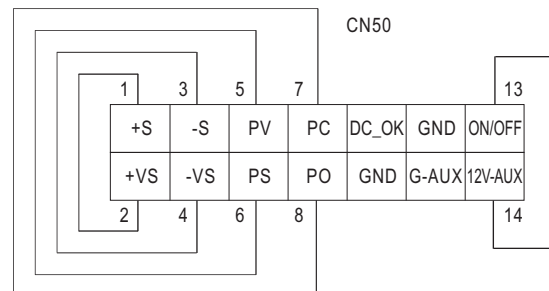
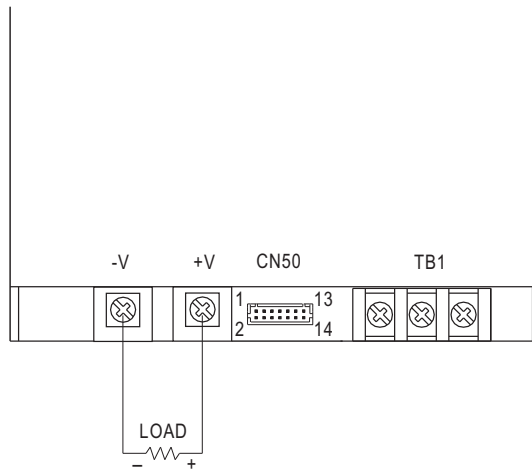
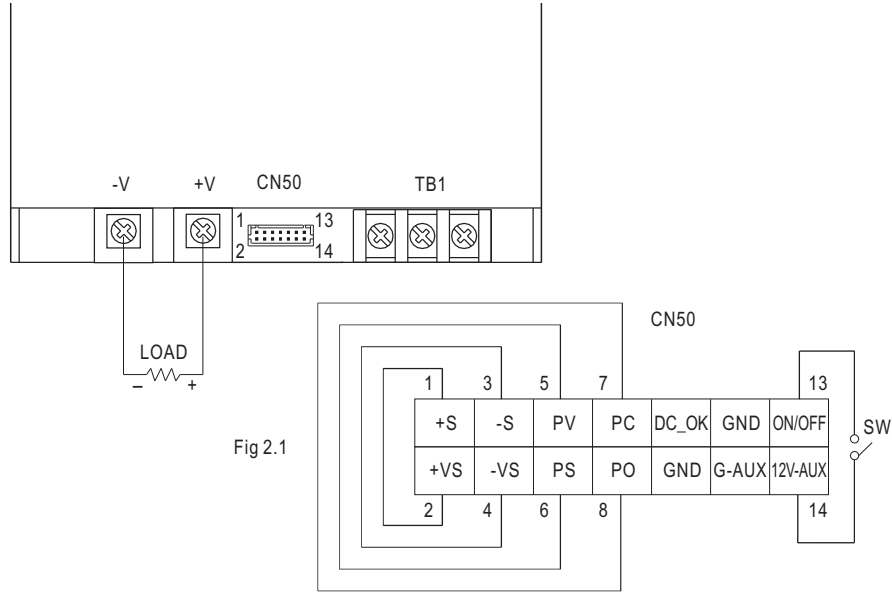

Fig 1.1 (Shorting connector)

2.Remote ON/OFF

The PSU can be turned ON/OFF by using the "Remote ON/OFF" function

| Between ON/OFF(pin13) and 12V-AUX(pin14) | Output Status |
|--|---------------|
| SW close (Short) | PSU ON |
| SW open (Open) | PSU OFF |



3.DC_OK signal

"DC_OK" is an open collector signal.

It indicates the output status of the PSU. It can operate in two ways : One is sinking current from external TTL signal ; the other is sending out a TTL voltage signal.

3-1 Sink current :

The maximum sink current is 10mA and the maximum external voltage is 5.6V.

3-2 TTL voltage signal :

| Between DC- OK(pin9) and GND(pin10&11) | Output Status |
|--|---------------|
| 0 ~ 1V | PSU ON |
| 3.3 ~ 5.6V | PSU OFF |

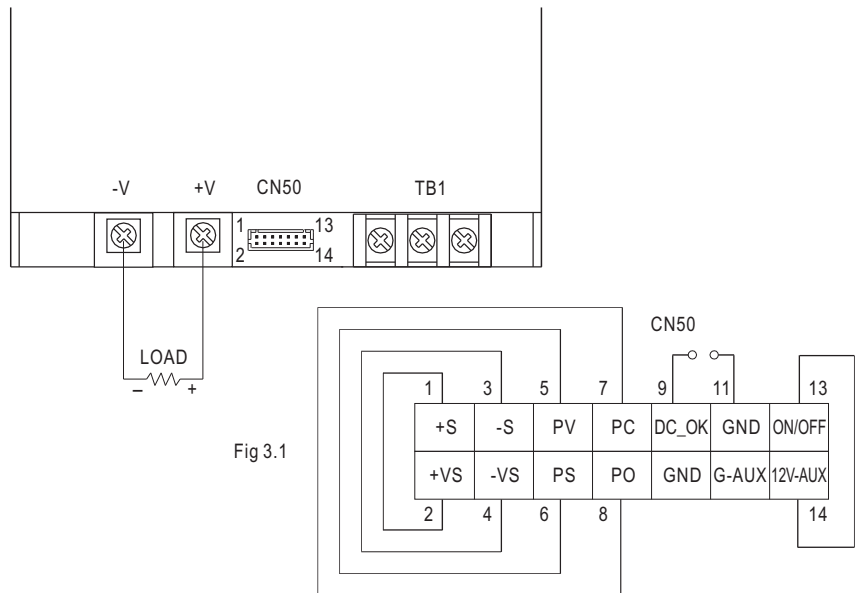

4.Remote Sense

The remote sensing compensates voltage drop on the load wiring up to 0.5V.

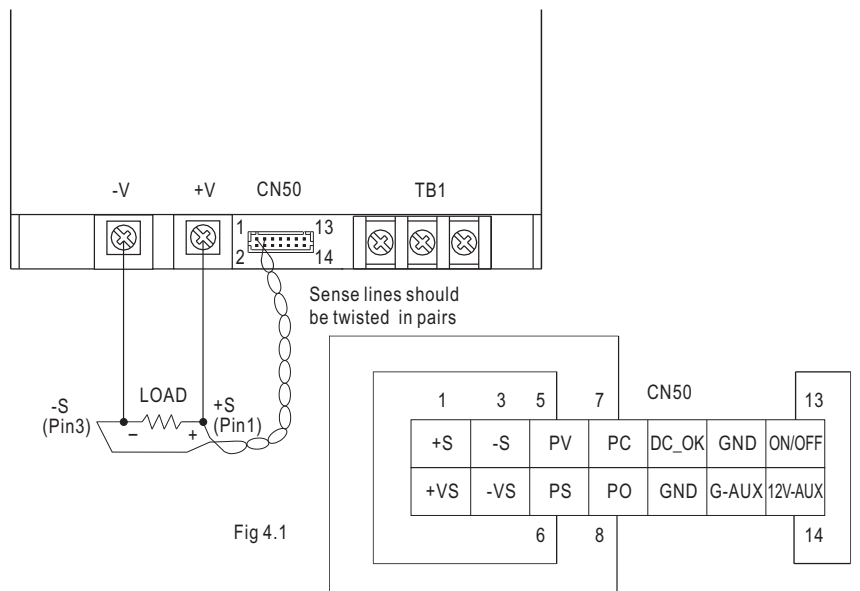

5. Output Voltage TRIM

Output voltage of RSP-750 can be trimmed between 40% ~ 110% of its rated value by the following methods :

(1) Using an external DC source (1~5.5VDC) between "PV"(pin5) and "GND"(pin10,11) that is shown in Fig5.1

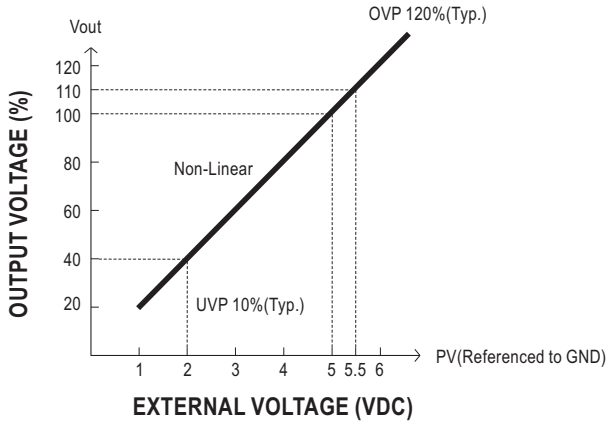

Note: External voltage < 0.5V Vo may be the UVP need to restart.

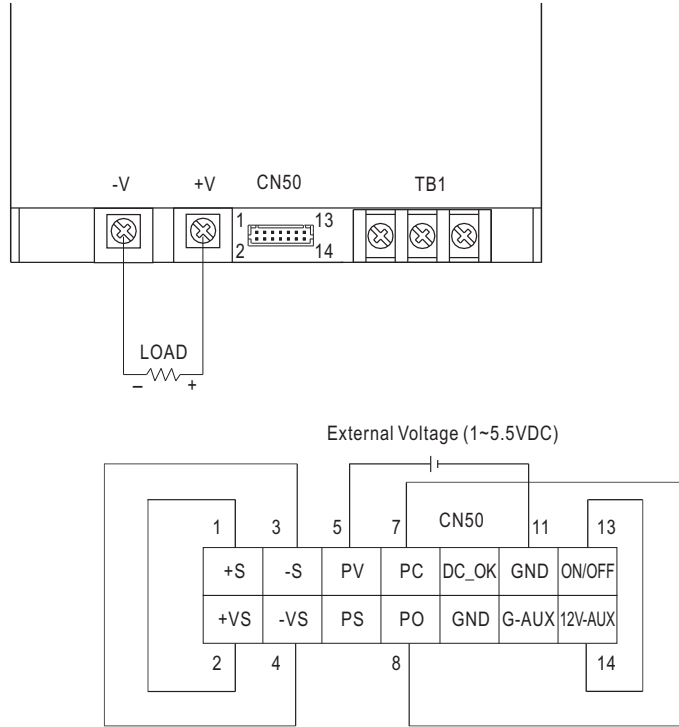

Fig 5.1

6. Output Current TRIM

Output current of RSP-750 can be trimmed between 40% ~ 110% of its rated value by the following methods :

(1) Using external voltage source between "PC"(pin7) and "GND"(pin10,11) that is shown in Fig6.1

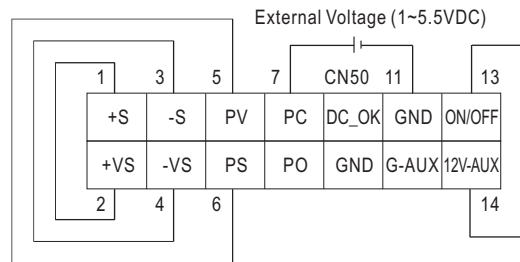
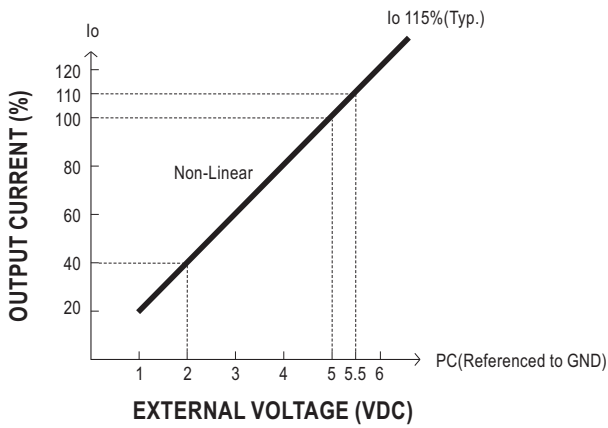

Fig 6.1