

Technical Description

Products: UG wire connector, two-wire inline joints on telephone drop wire of phosphor bronze with plated tin conductors, which will be suitable for crimping tool shown.



UG_WLL Specifications

Model No.	UG_WLL
Applicable wires	0.4-0.9mm (19-26AWG)
Max OD	2.08mm
Colour	Green
Poles	2Pin
Description	Sealed moisture-resistant 2 wire connector with pre-crimp feature for solid copper cable
Packing	100no pieces per bag

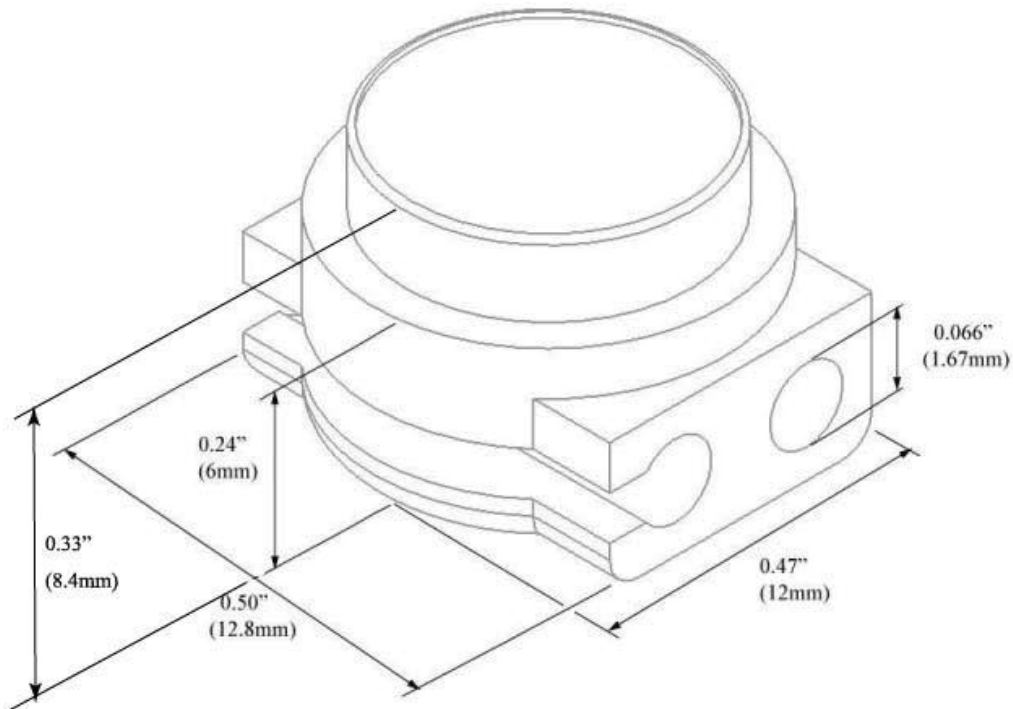

- 2.3. The connector can provide total environmental sealing around IDC-contacts.
3. Physical Characteristics, for more details, refer to technical drawing.
4. Material Suitability
 - 4.1. The material component:
 - 4.1.1. Plastic part: durable polycarbonate with durable, high impact material, Green lid and Transparent bottom.
 - 4.1.2. Contact pin: phosphor bronze with plated tin surface.
 - 4.1.3. The filling compound is prepared from fully synthetic dimethylsilicone fluid.
 - 4.2. All materials is suitable for operation in the tropic with maximum temperature up to 70°C.
 - 4.3. All materials used in the connectors shall be non-toxic and dermatologically safe.
 - 4.4. Connectors can retain the electrical & mechanical properties in the test report over working temperature range -30°C to 70°C and humidity range of 0% to 95%.