

Spartan GoCam™ Cellular Camera

User Manual

Model GC-W4Gb (Ghost)

connected by
verizon✓



**SPARTAN
CAMERA**

Important: Please read this manual
carefully before using your camera.

Thank you for choosing the Spartan GoCam. This manual will help you get the most out of your new device. You will also find this manual, other technical articles and more information about your camera and using Premium service at:
www.spartancamera.com.

If you experience any difficulties operating this product, **please do not return it to the store**. Call Tech Support at 770-582-0004 9 AM – 6 PM EST, Monday – Friday or email us at support@spartancamera.com.

Table of Contents

Package Contents	1
Camera Body and Ports	1
Camera Buttons.....	2
Activate Cellular Service.....	2
Spartan Camera	2
Verizon™	2
Set Up the Camera.....	2
Install the Spartan Camera Management App.....	3
Connect the Camera to the Verizon™ Network.....	3
Register and Set Up the Camera.....	3
Premium vs. Auto	3
Premium Setup.....	4
Complete Camera Setup	4
Test the Camera and Portal/App.....	5
Auto Setup.....	5
Complete Physical Camera Setup.....	5
Camera Settings.....	5
The Info Strip on Photos.....	7
Test the Camera	7
Photo, instant send mode	7
Photo, send mode off.....	7
Video.....	8
Access Photos or Videos.....	8
View a Photo.....	8
Watch a Video.....	8
Delete Photo or Video.....	8
Firmware Update	8
Premium	8
Auto	8
Manual Firmware Update.....	8
Technical Specifications.....	9
Manufacturer Limited Warranty.....	9
Terms and Conditions	9
Shipping.....	10
Proof of Purchase or Proof of Warranty Coverage...	10
Exclusions and Limitations.....	10

Unclaimed Items.....	11
Camera Repair.....	11
Privacy Policy.....	11
How Do We Use Your Email Address?.....	11
Do We Use Cookies?	11
Security Measures.....	11
Retention and Deletion.....	11
Terms of Use	12
About Us	12
Our Customers.....	12
Membership Responsibilities.....	12
Cost and Pricing.....	12
Content Limits	12
Content & Privacy.....	12
Limits on Use	13
Other Important Guidelines	13
Things to Keep in Mind.....	14
Image Delivery	14

Package Contents

Camera
Antenna
Mounting strap
Quick Start Guide
SIM card

Camera Body and Ports

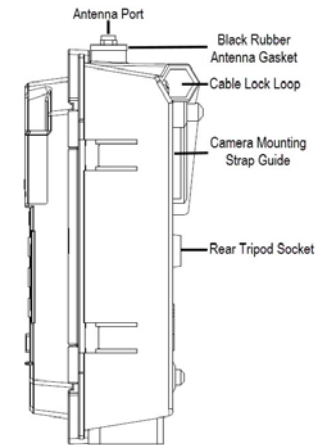
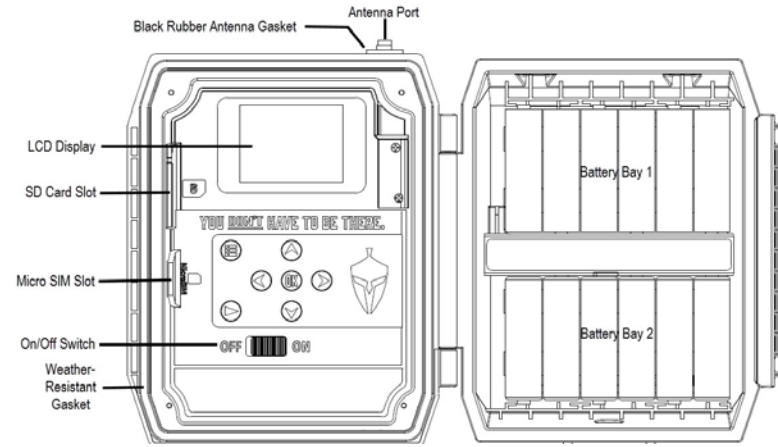
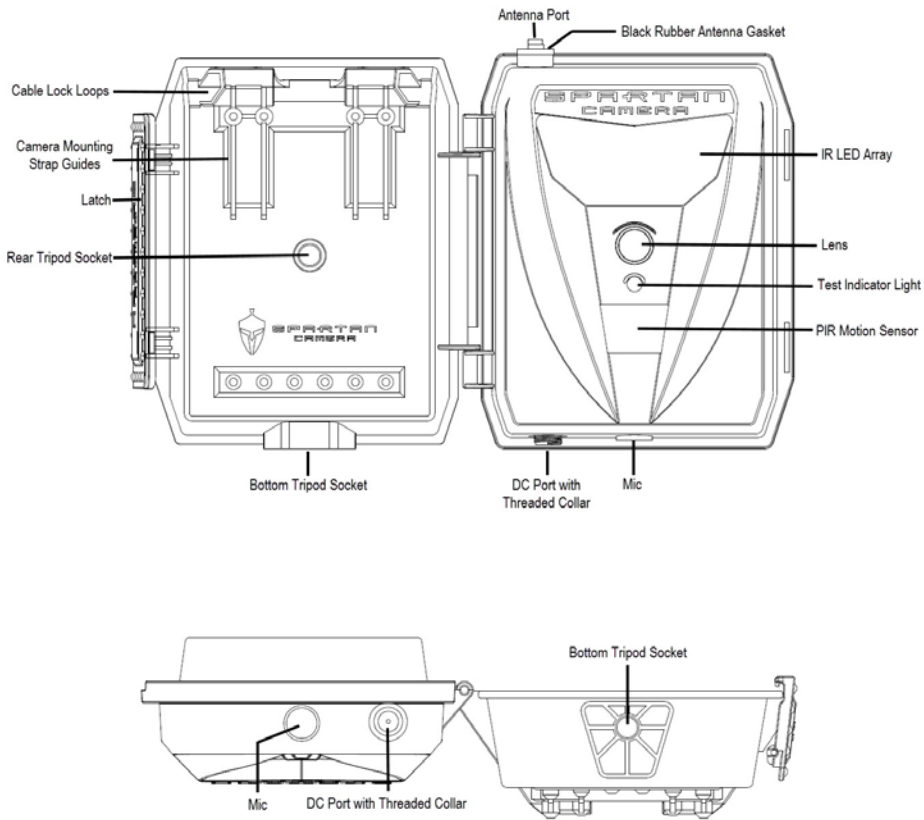

Camera Buttons

- **☰ (Menu):**
 - *Preview mode*: enter the *Setup* menu.
 - *Setup mode* (menus): Go back one menu level. (If in a submenu, return to the main menu. If at the main menu, exit *Setup mode*.)
 - *Playback mode*: display the *Delete* menu so you can choose to *Del One* or *Del ALL*.
- **Arrows ▲▼◀▶:**
 - *Setup mode*: move between menu items, change values.
 - *Playback mode*: ◀▶ move through photos/videos
 - *Playback mode*, photos: ▲ zoom in, ▼ zoom out. When zoomed in, press **OK** then use ▲▼◀▶ to pan the image.
- **OK:**
 - *Menu mode*: save parameter settings.
 - *Preview mode*: take a photo or start recording a video manually.
 - *Playback mode*, videos: play/pause video.
- **Playback button ▶**: In the preview window, switch between *Playback* and *Preview* modes
- **Shortcuts in *Preview mode*:**
 - ▲ selects *Video mode*.
 - ▼ selects *Camera mode*.
 - **OK** takes a picture or records a video manually.
 - Long press ◀ displays the *Arm camera?* choices, *Yes* or *No*, to arm the camera manually.
 - Long press ▶ displays power information.
- **Power Switch**: OFF is to the left. ON is to the right. The camera will arm itself automatically after it stays idle in *Setup* mode for three minutes.

Activate Cellular Service

Cellular service is required if you want to have photos delivered to your mobile device and/or email, regardless of whether you use Premium or Auto service for photo delivery. Cellular service enables the camera to send photos, status reports, and videos. (Premium service required for video transmission.)

You may purchase cellular service either from Spartan Camera or from Verizon (by adding it to your existing cell phone plan). Data service through Spartan Camera includes premium service at no additional charge.

Before you begin, locate your camera's IMEI number, which is printed on a sticker inside the camera.

Spartan Camera

Data service from Spartan Camera includes Premium service (app, portal).

1. Log in to your account at <https://my.spartancamera.com/>. If you don't have an account, you must register and then you'll be able to log in.
2. In your account, go to SHOP > DATA SERVICE, enter your camera's IMEI, and choose a data plan.

Verizon™

If you already use Verizon™ Wireless as your cellular carrier, you can add the camera to your phone plan by calling Verizon Customer Support at 800-775-8098, logging into your Verizon account at www.verizonwireless.com, or by taking your camera to a Verizon™ store.

If you want to use Premium service (app, portal), you can purchase that from Spartan Camera for \$3-4/month.

Set Up the Camera

1. With the power switch **OFF**, insert batteries into the battery compartment. Use 12 (recommended) or 6 (either top or bottom bay) 1.2-1.5v AA batteries or you can use an external power source with or without internal batteries.

The following types of AA batteries can be used:

- High-performance alkaline
- Lithium (Li-ion)
- Rechargeable NiMH

For longer battery life, you can connect the camera to a 12V external battery (with or without solar panel) or to a direct-connect solar panel (no external battery). When using a direct-connect solar panel, we recommend using 6 AA batteries (in either the top or bottom bay).

2. If the SIM card is installed, the punched-out SIM carrier will be in the tri-folder. If the SIM card is not installed, punch out the *mid-size* (micro) SIM, not the smallest (nano) SIM and install it in the SIM slot.
3. Insert an *unlocked* SD card (name brand; up to 32 G; class 10; standard size, *not microSD with or without adapter*) into the SD card slot. Refer to the card symbol on the case for proper orientation.
4. With the rubber gasket between the base of the antenna and the antenna jack on the top of the camera, screw the antenna onto the antenna jack. The rubber gasket must be in place to prevent leaks. Make sure the antenna is screwed in all the way but be careful not to over-tighten it.

Install the Spartan Camera Management App

1. If you plan to use the app (Premium service) and it is not already installed on your smart phone or tablet, download and install the Spartan Camera Management app from the Google™ Play Store™ or Apple™ App Store™.
2. Using the app, log in using the email associated with your Spartan Camera account. If you do not have an account, create one using the app.

Connect the Camera to the Verizon™ Network

1. Slide the power switch to the ON position. The camera will enter *Preview* mode. The screen will display *Searching network, please wait. Please do not press any keys.*, then a tower symbol, signal strength bars, and *Verizon* will appear briefly at top left corner of the screen.

Register and Set Up the Camera

1. The Setup Wizard will start.
2. Use ◀ and ▶ to scroll through the choices and select your Timezone then press the **OK** button to *Update*.
3. After a few seconds, the update should be successful and the date, time, and timezone will be displayed on the screen. Press the **OK** button to proceed to the *Next* screen.
4. On the *Add to Spartan Camera account*, choose either:
 - a. *Using the mobile app* then press the **OK** button.
 - i. On the *Home* screen of the app on your mobile device, tap the + in the upper left corner.
 - ii. Type the IMEI (from the camera screen or sticker) or scan the code on the box then tap *Next*.
 - iii. When asked if you have purchased data service, tap *Yes*.
 - iv. Type the registration code that is shown on the camera screen, check the *Terms of Use and Privacy Policy* box, and tap *Add*. You should see a *Successful* message and the app will display the *Home* screen with your new camera listed there.
 - b. *Using the camera* then press the **OK** button.
 - i. Follow the prompts to enter your email address, then return to the screen that displays your email address, then press the **OK** button to Register. The camera will display message that the email has been sent.
 - ii. Check your email account for the message, click the link in the message, then log in to your account (or follow the prompts to create one if you don't already have one). Your camera will be displayed on the portal CAMERA MANAGEMENT screen.
 - iii. On the camera, press the **OK** button to verify that registration is complete, then press the **☰ (Menu)** button to return to the *Preview* screen.

5. Format the SD card. *It is very important that you format the SD card in the camera before using it and it is a good idea to format it again ever so often.*
 - a. Press the **☰ (Menu)** button to access the menu.
 - b. Navigate to the *System* tab.
 - c. Scroll down to *Format*.
 - d. Press the **OK** button.
 - e. Select *Yes*.
 - f. Press the **OK** button again.
 - g. Press the **☰ (Menu)** button twice to return to the *Preview* screen.
6. Take/send a manual photo:
 - a. With the camera displaying the *Preview* screen, aim it at something and press **OK** to take a picture.
 - b. Press **OK** again to send the picture.
 - c. The screen will show *Setting...*, *Sending...*, *Sent*.
7. Decide whether you will be using Premium service (recommended, included with Spartan Camera data plans or first month free trial when you use Verizon™ data) or Auto service by reviewing the information in the next section, *Premium vs. Auto*. If you will be using Premium, go to *Premium Setup* on page 4. If you will be using Auto, go to *Auto Setup* on page 5.

Premium vs. Auto

We recommend that you run your camera using our Premium service. The following table should help you decide. Every camera comes with one free month of Premium service, which does not require that you subscribe to anything or provide any sort of payment information and will not auto renew unless you purchase credits for service. You are encouraged to try Premium, no strings attached, to see how you like it. Premium service is included at no extra charge with Spartan Camera data plans. When using Verizon data plans, additional months of Premium service cost \$3-4/month, depending on how many credits (months) you buy at a time.

Feature	Premium with app ¹	Premium without app	Auto
Change settings			
All (using portal) All (using app)	Yes Yes	Yes N/A	(only by using camera's menu options)
Picture delivery			
Portal App Email ²	Yes Yes Yes (up to 4)	Yes N/A Yes (up to 4)	N/A N/A Yes (1)

Feature	Premium with app ¹	Premium without app	Auto
Thumbnail size			
Normal (640 * 480)	Yes	Yes	Yes
Large (1280 * 960)	Yes	Yes	No
Video delivery			
320 * 240 or 1024 * 576 (5 sec or 10 sec)	Yes	Portal only	No
Batch mode delivery			
Set batch mode in app or on portal, set batch send times using scheduled events	Yes	Yes	N/A
Daily status report			
Portal	Yes	Yes	N/A
App	Yes	N/A	N/A
Email ²	Yes	Yes	Yes
Scheduled events (up to 9 additional status reports, scheduled pictures, batch sending)			
Portal	Yes	Yes	N/A
App	Yes	N/A	N/A
Email ²	Yes	Yes	No
Request HD photo			
Portal	Yes	Yes	N/A
App	Yes	Yes	N/A
Photos stored on server for 30 days	Yes	Yes	NA
Firmware update			
Over The Air (OTA via portal)	Yes	Yes	N/A
Manually (SD card)	Yes	Yes	Yes
Cost per month	\$0 when using Spartan Camera data plans; \$3-4 when using Verizon data plans		\$0

¹ Android and iOS versions of the app are available for smart phones and tablets with newer versions of the OS.

² Email refers to regular email addresses as well as to your device's phone number in your carrier's email format (e.g., 5555551212@vzwpix.com or 5555551212@mms.att.net). Note: While you can use your phone number email address, that is not recommended because carriers will occasionally block some MMS messages and senders, which can result in your not receiving pictures from your camera. *Spartan Camera does not guarantee the delivery of MMS messages or emails.*

We recommend that you set up, test, and use your camera at home before deploying it, especially if this is new technology to you.

Premium Setup

Complete Camera Setup

Using either the app (*Home*, , *Camera Settings*) or your account on the portal (www.spartancamera.com, CAMERA MANAGEMENT > Manage Camera > Change Settings) to complete the following:

1. Choose and set all the settings you want to use.
2. It is recommended that you set several scheduled events, either status reports or photos. There are nine available events for you to set, plus the default daily status report that you can set the time for. You will probably want to use most or all available events at least for status reports throughout the day so that you don't have to wait too long to get requested HD photos or video downloads.

You may want to set some scheduled events to take photos at specific times (e.g., 9 AM and 9 PM so that you will get at least two pictures every day). This is especially useful if your camera is in a low-traffic area. The scheduled photos are reassurance that your camera is still there and is still working.
3. When you are done, click *Schedule a Settings Update* (portal) or tap *Update* (app). To force the camera to contact the server and update settings, take and send a manual photo. (In SETUP mode, click OK twice. Watch the screen and after the photo is sent, you will see a message that the settings have been updated.)
4. Update the camera firmware if your camera's firmware is not the latest version. Refer to the **Firmware Update** section on page 8.
 - a. On the portal, select *MY CAMERAS > FIRMWARE UPDATE*.
 - b. Compare the date of the firmware version listed for your camera to the date of the latest version.
 - c. If the latest version is more recent than the one on your camera, click *Update*.
 - d. Take and send another manual photo. After the screen says the photo has been sent, it will indicate that it is downloading and updating the FW, then it will restart and come back up in *Setup* mode.

Test the Camera and Portal/App

1. Arm your camera and walk test it. The camera will arm itself automatically after being idle in SETUP mode for 3 minutes or you can arm it manually by long pressing ◀ then choosing *Yes*.
2. View the photos on the app or the web portal:
 - a. Select *MY CAMERAS > CAMERA MANAGEMENT* or *MANAGE PHOTOS*.
 - b. Refresh the browser periodically.
3. Go to *Complete Physical Camera Setup* on page 5.

Auto Setup

Now that you have connected your camera to the Verizon™ network, you are ready to complete the setup on your camera.

1. With the camera in SETUP mode (switch in the ON position, screen in *Preview* mode), press the **☰ (Menu)** button then use the arrow buttons to navigate to the *Wireless Settings* tab and move through the submenu items.
 - a. *Send Mode*: select *Instant*, then specify the number of photos to send each day. Enter *0* if you want all photos to be sent.
 - b. *Send Via*: select *Auto*.
 - c. With *Auto* selected for *Send Via*, move to *Recipient*, press **OK** then enter one destination email address. This may be either a regular email address or a device email address in the carrier's picture email format (e.g., 5555551212@vzwpix.com or 5555551212@mms.att.net). Note: While you can use your phone number email address, that is not recommended because carriers occasionally block some MMS messages and senders, which can result in your not receiving pictures from your camera. Spartan Camera does not guarantee the delivery of emails.
 - d. *Name Tag*: enter the name for your camera, up to 8 characters, that will appear on the picture info strip.
 - e. *Power Saving*: *On* provides longer battery life because the camera connects to the network only when it needs to send a photo or status report, *Off* provides slightly faster transmission speeds because the camera stays connected to the network all the time. *On* is recommended.
 - f. Press **OK** to save your changes.
 - g. Press the **☰ (Menu)** button to return to the main menu.
2. Refer to *Manual Firmware Update* on page 8 and update your camera's firmware if necessary.
3. Set the other parameters (*Camera Settings*, *Trigger Settings*, *System Settings*) using the information in the tables starting on page 6. It is probably best to set the clock last.

4. Once you have set all the parameters, press the **☰ (Menu)** button to return to the *Preview* screen.
5. When the camera shows that it is logged into the network, perform the "Hello test" to confirm that the camera is online.
 - a. Press the **☰ (Menu)** button.
 - b. Scroll to the *Wireless Settings* tab.
 - c. Under *Diagnostics*, select *Hello test* then press the **OK** button. If your camera is connected to the network properly, you will see the message *Success*.
6. To test that the camera is taking and sending pictures properly, in *Preview* mode, press **OK** to take a picture then **OK** again to send it. If you are not setting up the camera to send pictures, you may want to test your camera using the instructions on page 7.
7. Arm your camera and walk test it. The camera will arm itself automatically after being on for 3 minutes or you can arm it manually by long pressing ◀ then choosing *Yes*.

Complete Physical Camera Setup

1. After setting up and testing the camera, position it on the target area and arm it. It will arm itself after being idle for 3 minutes in SETUP mode, or you can arm it manually by long pressing ◀ then choosing *Yes*. The camera will take pictures as programmed. The height you mount your camera depends on what your targets are, but 2-4 feet off the ground is generally best for wildlife, depending on the size of the animals you want to photograph.
2. The green light on the front of the camera should flash for a few seconds to give you time to move out of the area.
3. *Important*: Before you retrieve the SD card or change the settings, turn the camera off by pushing the power switch to the OFF position.

Even in the OFF mode, the camera consumes a small amount of battery power. You should remove the batteries if the camera will not be in use for an extended time.

Camera Settings

The following tables list the settings that are available.

When using Premium service, use the app or portal, not the camera's internal menus, to set your camera.

When using Auto, press the **☰ (Menu)** button to access the *Setup* menu on the camera. Navigate the menus using the following keys:

- Press **◀** or **▶** to move between the tabs (submenus).
- Press **▲** or **▼** to move among the submenu items.
- Press **◀** or **▶** to change the value for an item.
- Press the **OK** button to save all changes you've made to settings in a tab.
- Press **☰ (Menu)** to return to the main menu (tabs) or to exit *Setup* mode (back one level).

Setting Items		Description	
Camera Settings	Mode	Photo, Video, or Photo + Video.	
	Photo Size	3MP, 5MP, or 8MP.	
	Photo Burst	Photo: 1, 2, 3. Set the number of images taken for each trigger. The camera will transmit all photos when burst is 2 or 3. Burst Interval: Short, 1 sec, 2 sec, 3 sec. The time between burst photos if Photo Burst is set to 2 or 3.	
		Photo + Video: 1 photo only	
		Transmittable with Premium, not transmittable with Auto or with Send OFF	
	Video Size	320 * 200	5 Sec, 10 Sec
		1024 * 576	
		Not transmittable in any mode (Send OFF only)	
		720P (native) 1080P (interpolated)	1-30 seconds, selectable in 1-second increments.
	Video Length	5 sec, 10 sec (320*200 or 1024*576)	
1-30 seconds, selectable in 1-second increments (720P, 1080P).			
Sound	On/Off		

Setting Items		Description
Trigger Settings	Sensitivity	Off (turns off motion sensor) Low (temps below 10° F.) Normal (10° F-80° F) High (temps above 80° F).
	Trigger Interval	Time between when a motion-triggered photo is sent and the next photo can be triggered. Options: 0-55 seconds in 5-second intervals, 1-60 minutes in 1-minute intervals.

Setting Items		Description
Trigger Settings (cont'd)	Time Lapse	The camera will take pictures at specified intervals. When the camera is in Time Lapse mode, it also will be triggered by motion unless Sensitivity is set to Off. Options: 30-55 seconds in 5-second intervals, 1-59 minutes in 1-minute intervals, 1-8 hours in 1-hour intervals.
	Start-Stop 1 & 2	The camera can be set to operate using different settings during specific time periods. To enable this function, select <i>On</i> then press OK to access the <i>Start-Stop</i> menu. You can set one or two start/stop intervals. For each, you can set start and stop times, trigger interval, and time lapse interval. The trigger intervals and time lapse intervals are the same as for the regular <i>Trigger Interval</i> and <i>Time Lapse</i> settings. The start-stop setting will override all other general camera settings. If you set two start/stop times, make sure that the times do not overlap.
	Work Day	Select <i>All</i> or one or more days of the week for the camera to take photos.

Setting Items		Description
System Settings	Clock	Set the date and time. If you want the photo info strip to show the correct date and time, you must set the clock when using Auto or regular trail camera mode. If you are using Premium, set the time zone from the app or web portal and the camera will maintain the correct date and time by getting it from the server.
	Arm Camera	Yes/No. Choose Yes to arm the camera immediately. You can also arm it by long pressing ◀ in <i>Preview</i> mode and choosing Yes.
	Time Stamp	On if you want the photo info strip to show the date/time, Off if you don't.
	Flash Power	High (distances greater than 15 feet) Low (distances of 15 feet or less)
	Format	Format the SD card. (This will erase all data on the SD card and cannot be undone.)
	Overwrite	On or Off. The On setting sets the camera to delete the oldest photo/video to write the newest if the SD card is full. If this is set to Off, the camera will stop taking pictures or

Setting Items	Description
	recording videos when the SD card is full.
Default	Restore all settings to factory default values.
Information	Show hardware and firmware versions and IMEI.
Password	Off/On. Set a 6-digit password.

Setting Items	Description	
System Settings (cont'd)	Beep	On/Off
	FW Update	Manual firmware update from SD card
	LED Indicator	On/Off
	Debug Switch	Off/On. Useful to help tech support troubleshoot
	Camera Server	For testing purposes only. Not for end-user use.
Save Log	On/Off. Used to save logs to SD card when Debug Switch is On.	

Setting Items	Description	
Wireless Settings	Send Mode	Instant (send photo instantly) Batch (Premium only, send photos at specified times) Off (camera functions as a regular trail camera).
	Send Via	Premium or Auto.
	Recipient	Auto: input one recipient email address. (Premium: use the web portal to specify email recipients.)
	Name Tag	Up to 8 characters to appear on the photo info strip. (Auto or regular trail cam mode. For Premium, use the app or portal.)
	Power Saving	On to conserve power, photo delivery takes a few seconds longer because the camera only connects to the network to send a photo or status report; Off for slightly faster photo delivery but shorter battery life because the camera stays connected to the network all the time. (Auto: use the setting in the camera menu. Premium: use the setting in the app/portal.)
	Register Code	Get the registration code needed to add the camera to your Premium account.
	Register Email	Email address linked to your Spartan Camera account.
	Diagnostic	Hello Test (to test connectivity) Module FW Update (tech support use only) APN Setting (tech support use only)

The Info Strip on Photos

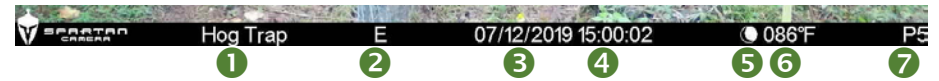

1 Nametag

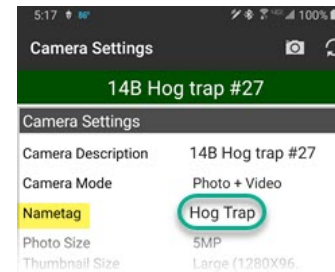

- 2 Camera triggered for:
M = Motion
E = scheduled Event or manual photo
T = Time lapse
F = photo sent to confirm that the camera has completed the Format command

- 3 Date
4 Time (24-hour format only)
5 Moon phase
6 Temperature

7 Power level:

5 = full voltage
3 = voltage getting low, prepare to change batteries (fully-charged rechargeable batteries may show this because they start with lower voltage than alkaline or lithium ion batteries)

1 = voltage very low, change batteries ASAP
0 = batteries are just about dead

Note: a camera running only on the internal battery and a direct-connect solar panel (i.e., no AA or external battery) will never show more than P1 at night.

Test the Camera

Photo, instant send mode

1. Press the **OK** button to take a picture.
2. Press the **OK** button to send the picture to the portal/app (Premium) or recipient programmed into the camera (Auto) or the **☰ (Menu)** button not to send the photo.

Photo, send mode off

1. Press the **OK** button to take a picture.

2. Review the picture using the instructions that appear in **Access Photos or Videos** section that follows.

Video

1. Press the **OK** button to start recording a video. The camera will record video until you stop it or it runs out of storage space on the SD card; the video length you set does not apply to manually-recorded videos.
2. Press the **OK** button to stop recording the video.
3. Review the video using the instructions that appear later in this section.

Access Photos or Videos

1. With the camera in *Preview* mode, press the playback button ► to switch to *Playback* mode to view photos or videos.
2. Use ◀ or ▶ to move through the photos or videos.
3. Press the playback button ► again to exit *Playback* mode. Press **OK** to start playing the video clips.
4. Press **OK** to stop playing and return to playback mode.

View a Photo

While viewing a photo, use ▲ to zoom in and ▼ to zoom out. While zoomed in, press **OK**, then use ▲▼◀▶ to pan the zoomed image.

Watch a Video

While viewing the opening frame of a video, press **OK** to play/pause the video.

Delete Photo or Video

Warning! Deleted files cannot be recovered!

1. While viewing a photo or video, press ■■ (Menu) to access *Delete Files*. to be able to select either *Delete Current File* or *Delete All Files*.
2. Press ▲ or ▼ to select either *Delete Current File* or *Delete All Files*.
3. Either press **OK** to execute (perform the deletion) or ■■ (Menu) to exit without deleting.

Firmware Update

It is important that you make sure your camera's firmware is current.

Premium

Over The Air (OTA) Firmware Update

If you are using Premium, the easiest way to perform a firmware update is Over The Air (OTA), which you can do using either the app or the portal.

App: On the Status Report page, there will be an **Update** button next to *Firmware Update* if your camera's firmware is not current. Click it. If the firmware is current, it will say *Firmware is up to date*.

Portal:

1. On www.spartancamera.com, log into your account, *CAMERA MANAGEMENT > CAMERAS > FIRMWARE UPDATE*.
2. If there is an *Update* button, click it. If the firmware is up to date, *Current* will appear in the *Action* column.

The FW should update after the next time the camera contacts the server to send a photo, video, or status report. If you have the camera in hand and you want to force it to happen immediately, take and send another manual photo. After the screen says the photo has been sent, it will indicate that it is downloading and updating the FW, then it will restart and return to *SETUP* mode.

If your camera will not update OTA, please use the **Manual Firmware Update** section that follows the **Auto** section below.

Auto

1. On the camera, in *Preview* mode, press ■■ (Menu), *System Settings*, then scroll down to *Information* and press **OK**. The first part of *DSP* will be a date in the format YYYY/MM/DD. (e.g., 2019/02/12), which is the FW date.
2. On the web site, check the date of the current FW:
 - a. Using your computer, go to www.spartancamera.com.
 - b. *SUPPORT > FIRMWARE / SOFTWARE*
 - c. If the firmware on the web site for your camera model (GC-W4Gb) has a later date than the firmware on your camera, update it using the instructions in the **Manual Firmware Update** section that follows.

Manual Firmware Update

You must update the firmware manually if you are using the camera in Auto mode or if you are having trouble with the OTA update in Premium. To perform a manual firmware update:

1. If you haven't already determined the date of the firmware on your camera, with your camera in *Preview* mode, on the *System* menu, scroll down to *Information*, press **OK**, and note the date of the FW Ver.

2. If you are using Premium and OTA firmware update has not completed, cancel the OTA update request in the app (Status Report page) or on the portal.
3. Using your computer, go to www.spartancamera.com.
4. **SUPPORT > FIRMWARE / SOFTWARE**
5. If the date of the firmware on the web portal for the GC-W4Gb is more recent than the date of the FW shown on the Information screen on your camera, click the *Download* button beside the camera model and save the file to your computer. Make sure you choose the correct model camera.
6. With an empty SD card (preferably one that was formatted in your camera) in your computer's SD card reader, copy the file from your computer to the SD card. It should not be inside any folder on the card.
7. Insert the SD card back into the camera.
8. To apply the firmware, with the camera in SETUP mode:
 - a. Press the **☰ (Menu)** button.
 - b. On the *System Settings* tab, select *FW Update*, press **OK**, select *Yes*, press **OK**, then watch the screen for progress. When the FW update is complete, the camera will restart.
9. On the *System Settings* tab, choose *Information* and verify the firmware version has changed by checking the FW date.
10. Reset your camera's settings. If you are using Premium, request a setting update on the app or portal, then take and send a manual photo. If you are using Auto, reset your settings using the camera's menus.

Technical Specifications

Picture Resolution	3 MP / 5 MP / 8MP
Video Resolution	320*240@30 fps 1024*576@30 fps 720p@30fps 1080p@10fps
Delivery Options	Premium, Auto, None (Send Off) Premium only: Instant or Batch send modes
Transmitted Images	Thumbnails: 640*480 or 1280*960 HD (upon request): 2048*1536 (3 MP) 2592*1944 (5 MP) 3264*2448 (8 MP)
Transmitted Videos	320*240@30 fps 1024*576@30 fps
Trigger Time	0.6s
Lens	FOV (Field of View) = 52°
Night Illumination	Blackout InfraRed Flash

Display Screen	2.0" LCD
Memory Card	up to 32GB
Trigger	Motion (PIR) / Timer (Time Lapse, Start-Stop)
PIR Sensitivity	Adjustable (High/Normal/Low/Off)
Temperature	-4 - +140F (Operation) -22 - +158F (Storage)
Trigger Interval	0s - 60 min
Time Lapse Interval	5s - 60s/1 min - 60 min/1 hr - 8 hrs
Photo Burst	1 - 3 (photo) or 1 (photo + video)
Video Length	5s, 10s (320*240, 1024*576)—transmittable via cellular network (app and portal only) 1 - 30s (720P, 1080P)—not transmittable
Power Supply	6 or 12 1.2-1.5v AA alkaline, lithium, or rechargeable optional: 12V external battery, AC power, direct-connect solar panel support built-in rechargeable 5300 mAh lithium battery
Stand-by Current	< 0.20 mA (< 5 mAh/day)
Sound Recording	Available
Mounting	Rear and bottom tripod threads / mounting strap / Python lock
Weight	1 lb. 4 oz.
Dimensions	5.3 x 6.1 x 3.4 inches
Operation Humidity	5% - 90%
IP Rating	65

Manufacturer Limited Warranty

Terms and Conditions

Spartan Camera (SC) warrants our Spartan Camera products against defects in material or workmanship for a period of two years from the original date of purchase of the product by a consumer (the "Warranty Period"). If a material or workmanship defect arises with regard to any Spartan Camera, and a valid claim is received within the Warranty Period, SC will (1) repair the camera using new or refurbished parts or (2) replace the camera with a new or refurbished product. For purposes of this limited warranty, "refurbished" means a product or part that has been substantially returned to its original

specifications. In the event of a defect, these are your exclusive remedies. The warranty on any replacement product provided under this warranty shall be for the unexpired portion of the warranty period applicable to the original product.

The warranty agreement, as defined here, is the sole controlling terms. No other warranty information as published by SC, relating to other products, applies to the Spartan Camera series.

Shipping

Initial shipping of items to SC for warranty coverage is the responsibility of the customer. SC has no responsibility for any items lost or damaged during incoming shipment. It is recommended that all shipments made by the customer be insured. Before shipping any items for warranty coverage, an RMA must be obtained via phone or the SC website. Any items received without a valid RMA may result in delays in service or loss of the item. If your RMA is approved, your RMA number is only valid for 30 days from the date of issue, and only for items originally listed on the RMA request form. In addition, SC reserves the right to charge a small shipping and handling fee in connection with the fulfillment of any valid claim. Please include \$11.95 for return shipping & insurance. (For U.S. customers only. CHECK OR MONEY ORDER ONLY, NON-REFUNDABLE). International customers pay different amount of shipping & insurance. We will send detailed information along with the RMA number.

Proof of Purchase or Proof of Warranty Coverage

We pride ourselves on providing top-quality scouting cameras for your hunting, research and security needs, and take quality seriously. We are constantly evolving our designs to ensure our products do the best job possible. When requesting warranty coverage, we may require the following:

- a) Warranty registration within 30 days of the original purchase date, via mail in warranty card or online at the SC website is **required** for warranty coverage to be valid.
- b) We may require proof that the claim is valid. In this regard, we may ask you to, for example, trouble shoot service issues via phone, e-mail or other electronic means, return your product to us for warranty coverage verification, or provide such other proof to allow us to determine the validity of warranty coverage on your claim. This most likely will require you to send your product in to us.
- c) We may require you to provide us with your purchase receipt as proof of purchase from an authorized dealer.

Exclusions and Limitations

Except for the limited warranty expressly set forth above or to the extent restricted or prohibited by applicable law, SC expressly disclaims any and all other warranties express or implied, including any warranty of quality, merchantability, or fitness for a particular purpose, and you specifically agree that SC shall not be liable for any special, incidental, indirect, punitive, or consequential damages for breach of any warranty of any type on any SC product.

In addition to and without limiting the generality of the foregoing disclaimers, the limited warranty does not, under any circumstances, cover the refund or reimbursement of the cost of any wireless data charges incurred while warranty services are being rendered. Wireless data plan management is solely the purview of the account holder and should be managed accordingly if warranty service is necessary.

Warranty coverage is specifically limited to the original purchaser of the product and does not extend to any subsequent parties. Warranty coverage is exclusively limited to purchases made through an authorized dealer or retailer.

The refurbished item will carry, (1) the remaining balance of the warranty period of the original warranted item, (2) 90-day limited warranty, whichever is longer. The repair or replacement does not extend the original warranty period.

This warranty is void if the product housing has been removed, if the product's label, logo or serial number has been removed.

The following item are expressly excluded from warranty coverage:

- Any damage, malfunction or degradation of performance resulting from use of the product in an environment not meeting the operating specifications set forth in the user manual. Spartan Cameras are very water resistant; however, they are not waterproof.
- Any damage, malfunction or degradation of performance resulting from failure to properly prepare and transport the product as prescribed in published product materials
- Any damage, malfunction or degradation of performance resulting from improper use or connection to incompatible batteries, power supplies or memory.
- Any damage resulting from attempts by personnel other than SC representatives to install, repair or service the product unless directed by a SC representative.
- The replacement of items that have been abused, misused, or tampered with in any way.

- The repair of an item that has been modified or integrated with other products when the effect of such modification or integration increases the time or difficulty of servicing the product or degrades performance or reliability.
- The performance of software or firmware updates or upgrades.
- The correction of user programming errors.

Unclaimed Items

It is the customer's responsibility to respond to any inquiry initialized from our warranty department. SC will only keep the returned goods for 6 months. Unclaimed returned item(s) will be discarded after 6 months.

If the product is beyond the warranty period, the price for repairing or replacing may vary. Please allow 6-8 weeks for delivery.

Camera Repair

There will be a charge for repairs not covered by the warranty. Please contact Spartan Camera to determine more information and to discuss repair options not covered under warranty.

Privacy Policy

Thank you for visiting www.spartancamera.com (the "Site") and reviewing the Privacy Policy of www.spartancamera.com. ("SC" or "we" or "us"). It is important to us that you understand what information we collect when you visit the Site either from a computer or a mobile device as well as any information that is uploaded to the site by your cameras. Herein we describe what we may do with that information for you below. This Privacy Policy also covers the collection of data from applications on mobile devices.

By using this Site, you consent to the terms of this Privacy Policy, and you signify your assent to all of the terms of this Privacy Policy and our Terms of Use. If you do not agree with any terms of this Privacy Policy or our Terms of Use, please do not use this Site or submit any personal information. Please take care to read our Privacy Policy to be sure you are informed about how your information may be used. Please also read our Terms of Use.

How Do We Use Your Email Address?

Spartan Camera will use your email address to contact you to manage your account. For example, we may contact you via email in cases where your account has zero premium credits and you have an active expiring camera as a convenience as well as error conditions relating to camera operation or wireless service issues. The web portal also allows you to maintain an email

contact list for the delivery of photos and status reports. These emails and delivery functions are under your control. We do not share your account email or email contacts publicly or with any other parties under any circumstances.

Do We Use Cookies?

We use HTTP (or HTML) cookies to collect non personal information, to help remember you on future visits primarily. In the event of using a site shopping cart then a cookie may also be required for an eCommerce purpose.

Security Measures

While Spartan Camera has security measures to help protect the information under our control, no data transmission over the Internet or any wireless network can be guaranteed to be 100% secure.

- SC tries to protect your personal information and ensure the security of your communications on our systems, by maintaining physical, organizational and technological safeguards (appropriate to the sensitivity of such information) designed to protect it against unauthorized use, disclosure or access of the personal information we collect on this Site. However, we cannot ensure or warrant that any information you transmit to us will stay safe and secure and you do so at your own risk.
- Your information may be stored in whole or in part on equipment or in facilities leased or licensed from others. Although SC tries to keep your information safe, it relies on the statements of those vendors regarding the safety and security of their storage equipment and services as part of its evaluation. By using the Site, you agree that SC is not responsible if the storage equipment and services provided by others are not working like they are supposed to, and that you will have to seek any remedies from those providers, not SC.

Retention and Deletion

We keep your personal information only so long as we need it for the purposes for which it was collected, for the products and services that you are using, or to meet any legal requirements. We have retention standards, which meet these requirements. We destroy your personal information when it is no longer needed. Photo uploads by your camera devices are currently maintained for a 30-day period. Each night photos that are 30 days or older are purged from the server. We urge you to maintain your own backups of your images based on your particular needs.

Terms of Use

The latest terms and conditions are available at www.spartancamera.com/privacyterms.

Thank you for visiting www.spartancamera.com (the "Site"), operated by SpartanCamera.com, Inc. ("SC" or "we" or "us"). Please carefully read these Terms of Use ("Terms") so you understand how we operate this Site, what we can offer and how we can work together. Please also read our Privacy Policy. By using the Site and the SC Services, you are agreeing to the Terms and Privacy Policy posted at the time of your visit.

About Us

Spartan Camera offers the Web Portal and associated Mobile Applications which are used to provide a premium function for the line of wireless cameras.

Our Customers

The Site is open to anyone, but some of the SC Services are only available to registered members ("Members"). You can visit the Site without registering and we will consider you a "User."

Membership Responsibilities

When you become a Member, you agree to the following:

- You have provided true information when you registered to be a Member;
- You have given us a valid email address, and we may confirm upon registration, or at any time thereafter, via a confirming e-mail which may require a response to complete your registration or keep it active;
- You will notify us if something changes;
- You are not breaking any laws when you use the SC Services; and
- You will not violate these Terms as a Member.

If you become a Member, you are responsible for the Content and activities in your account, for protecting your Content with a secure password and not sharing your password with anyone. We recommend using a combination of numbers, symbols and lower- and upper-case letters to create a secure password.

Spartan Camera reserves the right to terminate your Membership at any time (even if you've paid), without warning for any or no reason, with or without prior notice or explanation and without liability and can even take legal action if needed.

For example, please note that it is our policy to terminate the accounts of Members who repeatedly infringe the intellectual property rights of others. We

have a similar policy for Members who violate these Terms or commit illegal acts using the Site or Spartan Camera Services—although we may, in our discretion, instead deny, restrict or suspend access to all or any part of the Site or Spartan Camera Services or terminate a Member's account when something similar occurs.

You may cease use of the Services at any time. Even after you are no longer a Member, you will still be responsible for the promises you have made to us about your Content (defined below). You will be responsible for any damages that result from your breaking those promises as further outlined below.

Cost and Pricing

- Visiting: There is no cost to visit the Site or to register as a Member.
- Free Credit: Each newly registered Spartan GoCam camera will add one free credit to your account providing full use of the portal services for one month for one camera. This is not applicable to all models.
- Premium Service: These are in the form of monthly credits that you purchase online. A monthly credit will provide for a single camera to operate for one month on the web portal and in conjunction with our free mobile applications. If you are a user of one of these services, we consider you a "Paying Member." All Terms apply unless explicitly stated.
- When you subscribe to a Spartan Camera Data Plan, the plan will auto-renew either when the data plan has expired or you have reached the data limit, whichever comes first.

Content Limits

Spartan Camera continues to grow and get better because of users like you (Thank you!). Each camera that consumes a monthly Premium Service credit is provided with one month of photo uploads and other real time interactions using the web portal and mobile applications. Photos are maintained on our server for up to 30 days before they are individually purged. There are no restrictions on the number of photos a camera can upload including thumbnails and high res images during the 30 days of operation. Your device wireless plan covers the bandwidth used and your Premium Credit provides complete use of the portal and mobile apps for your active devices.

Content & Privacy

You retain all your rights to any Content you submit, upload or display on or while using Spartan Camera services. This means that you own all the Content you post and are responsible for its settings:

- Your content is considered private and not visible to other users or the public internet.
- It is considered a misuse of the Premium Service to provide your user credentials publicly and doing so may result in termination of your account and removal of your content.
- Providing direct links to your content is also prohibited.
- By allowing your camera to upload photos, you are confirming that the Content is yours—no one else’s—and that the uploading and use of your Content does not violate the privacy rights, publicity rights, copyrights, contract rights, intellectual property rights or human rights of somebody else. If we learn that you are infringing others’ rights or are using Content that is not yours, SC has the right to remove this Content and you agree that you are responsible for any costs associated with the infringement.
- SC may moderate Content. However, we are not responsible for what you have uploaded and we are under no obligation to modify or remove any inappropriate Content.
- If you stop using the Spartan Camera Services, your Content may remain on the Site unless you actively remove your Content. Photos will be purged after a 30-day retention period automatically.
- In order to continue to improve the Site and SC Services, we may use software and other things on the Site that we own or that have been licensed to us (“Spartan Camera Software”). Spartan Camera has also created the look, feel and architecture of the Site and has posted certain images and videos (“SC Content”). Together the SC Content and SC Software are the “SC Materials.” SC Materials are ours and remain ours. Except in viewing the Site, you agree that you will not copy, distribute, publicly perform, publicly display, reproduce or create derivative works from the SC Software.
- Our Webmaster and IT technicians reserve the right to investigate issues or problems on our server during the course of normal operation. This may mean that your content is visible to us during the diagnosis of said problems. We will take every precaution to maintain the privacy of your content at this time. If you are involved in a technical issue with the site software, it may be necessary to study your account settings and content during the diagnosis of the issue.

Limits on Use

- It is a violation of these Terms to disrupt the Site or the way it functions, interfere with other Users’ enjoyment of the Site or Spartan Camera Services or use the Site to deceive, harass or solicit people.

- It is also a violation to scrape the Site, fuser files, or otherwise make any use of data mining, robots or similar data gathering and extraction tools.
- It is up to Spartan Camera whether to terminate your use for violation of these prohibitions or similar activities.

Other Important Guidelines

- These Terms and the Privacy Policy can change. Again, please carefully read this document and our other policies. We may announce if any “big” changes are made, but so long as you’ve used the Site after the change, regardless of any separate notice, you agree to the current posted version of the Terms.
- Our Site is hosted in the US. There may be more or fewer protections for you in your country than here.
- Software available in connection with the Site and services offered through the Site (the “Software”) is further subject to United States export controls. No Software may be downloaded from the Spartan Camera Services or otherwise exported or re-exported in violation of U.S. export laws. Downloading or using the Software is at your sole risk.
- These Terms are governed by, and interpreted in keeping with, the laws of the State of Georgia, regardless of any conflict of law provisions. You and Spartan Camera agree to submit to the exclusive jurisdiction of the courts located within the State of Georgia to resolve any dispute arising out of the Agreement or the Spartan Camera Services. YOU AND Spartan Camera HEREBY EACH KNOWINGLY, VOLUNTARILY AND INTENTIONALLY WAIVE ANY RIGHT IT MAY HAVE TO A TRIAL BY JURY IN RESPECT OF ANY LITIGATION (INCLUDING BUT NOT LIMITED TO ANY CLAIMS, COUNTERCLAIMS, CROSS-CLAIMS, OR THIRD-PARTY CLAIMS) ARISING OUT OF, UNDER OR IN CONNECTION WITH THIS AGREEMENT. FURTHER, EACH PARTY HERETO CERTIFIES THAT NO REPRESENTATIVE OR AGENT OF EITHER PARTY HAS REPRESENTED, EXPRESSLY OR OTHERWISE, THAT SUCH PARTY WOULD NOT IN THE EVENT OF SUCH LITIGATION, SEEK TO ENFORCE THIS WAIVER OF RIGHT TO JURY TRIAL PROVISION. EACH OF THE PARTIES ACKNOWLEDGES THAT THIS SECTION IS A MATERIAL INDUCEMENT FOR THE OTHER PARTY ENTERING INTO THIS AGREEMENT.
- As a Member of SC Services, if you become aware of misuse of the SC Services by any person, please email abuse@spartancamera.com and include a sample of the misuse.
- You use the Site at your own risk and the Site and services are provided “AS IS.”

- We are not saying that the Site will meet any of your specific needs or that you will get any particular results if you use the Site. We are not responsible for the conduct of other Users on- or off-line.
- We encourage you to always keep backups of your Content. Spartan Camera is not responsible if any of your Content is deleted, or if any modification, suspension or discontinuation of the Site or services causes you to lose any Content—even if you're a Paying Member.
- While we make an effort to keep the Site up and running at all times, we are not responsible for any errors, omissions, interruptions, deletions, defects, delays in operation or transmission, communications line failure, theft or destruction or unauthorized access to, or alteration of, any User communication, whether the result of our maintenance of the Site or any problems or technical malfunction of any network, servers, software or equipment, Internet traffic or any other failure of any nature.
- We are not responsible for advertisements or applications or services that are posted on or through the Site, nor do we have any responsibility for the goods or services provided by our advertisers or via other websites or applications, including our print vendor.

Things to Keep in Mind

Though everything in these Terms and in our Privacy Policy is a binding contract, we need to let you know the following:

- **Limitation on Liability.** IN NO EVENT SHALL Spartan Camera BE LIABLE TO YOU OR ANY THIRD PARTY FOR ANY INDIRECT, CONSEQUENTIAL, EXEMPLARY, INCIDENTAL, SPECIAL OR PUNITIVE DAMAGES, INCLUDING LOST PROFIT DAMAGES ARISING FROM YOUR USE OF THE Spartan Camera SERVICES, EVEN IF Spartan Camera HAS BEEN ADVISED OF THE POSSIBILITY OF SUCH DAMAGES. NOTWITHSTANDING ANYTHING TO THE CONTRARY CONTAINED HEREIN, GOWIRELESS'S LIABILITY TO YOU FOR ANY CAUSE WHATSOEVER AND REGARDLESS OF THE FORM OF THE ACTION, WILL AT ALL TIMES BE LIMITED TO THE AMOUNT PAID, IF ANY, BY YOU TO Spartan Camera FOR THE Spartan Camera SERVICES DURING THE TERM OF MEMBERSHIP.
- **Your Indemnity to Us.** If you breach any of the representations made herein regarding your rights in the Content, or your uploading of Content violates any of the promises you have made, you agree to indemnify, defend and hold Spartan Camera, its subsidiaries, and affiliates, and their respective officers, agents, partners and employees, harmless from any loss, liability, claim, or demand, including reasonable attorneys' fees, made by any third party due to or arising out of your use of the Site and Spartan

Camera Services in violation of that and/or arising from any Content that you post on or through the Site and Spartan Camera Services.

- **Some Obligations Continue Even After You've Gone.** Even if you close your account or we terminate your Membership, you will still be responsible for indemnifying us for breaches that took place while you used the Site and Spartan Camera Services. Obligations you owed to us and Users of the Site, which by their nature are intended to survive closing or termination, will survive.

Image Delivery

- In order to comply with Internet and server protocols, any account that attempts to send images to an email address which repeatedly "bounces" or returns image messages as undeliverable will be blocked from service. Any email address associated with an account that results in a spam or violation of service report against Spartan Camera servers will be blocked from service.
- Due to the nature of image transmission via wireless networks, Spartan Camera is not responsible for delays in, or reception of, images transmitted by any Spartan camera.
- If you are using an MMS-to-email service provided by your wireless carrier and that service is discontinued or eliminated by your carrier, Spartan Camera is not responsible for the lack of this service or bound to provide a replacement.
- Spartan Camera reserves the right to make changes to Premium Service without notice.

The information in this document is subject to change without notice and should not be construed as a commitment by Spartan Camera. Spartan Camera assumes no responsibility for any errors that may appear in this document.

In no event shall Spartan Camera be liable for incidental or consequential damages arising from use of this document or the software and hardware described in this document.

This document and parts thereof must not be reproduced or copied without Spartan Camera written permission, and contents thereof must not be imparted to a third party nor be used for any unauthorized purpose. Contravention will be prosecuted.

Additional or updated copies of this document may be obtained from the Spartan Camera website.



S P A R T A N
C A M E R A

Customer Service Contact

E-mail: support@spartancamera.com

Website: www.spartancamera.com

Phone: 1-770-582-0004

11420 Johns Creek Pkwy, Bldg B

Johns Creek, GA 30097

U.S.A.