

- In addition to routine checks for each use, PPE should regularly undergo a detailed inspection by a competent person.  
 Petzl recommends an inspection every 12 months and after any exceptional event in the life of the product.
- PPE inspection should be done with the manufacturer's instructions available for reference. Download the instructions at [PETZL.COM](http://PETZL.COM)



## PRO TRAXION

### 1. Known product history

Any PPE showing unexpected degradation should be quarantined, pending a detailed inspection.

The user should:

- Provide precise information on the usage conditions.
- Report any exceptional event regarding his PPE.  
 (Examples: fall or fall arrest, use or storage at extreme temperatures, modification outside manufacturer's facilities...)

### 2. Preliminary observations

Verify the presence and legibility of the serial number and the CE mark.  
 Verify that the product lifetime has not been exceeded.  
 Compare with a new device to verify there are no modifications or missing parts.

### 3. Checking the moving side plate and the side plate locking system

- Check the condition of the moving side plate (marks, deformation, fouling, cracks...).

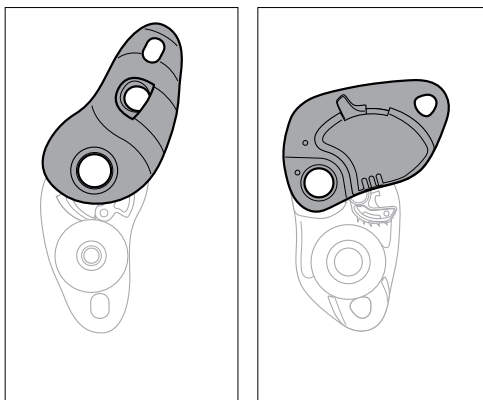

- On the P51A PRO TRAXION, check the condition of the catch on the moving side plate. If the pulley has been overloaded, this catch will be marked or broken.

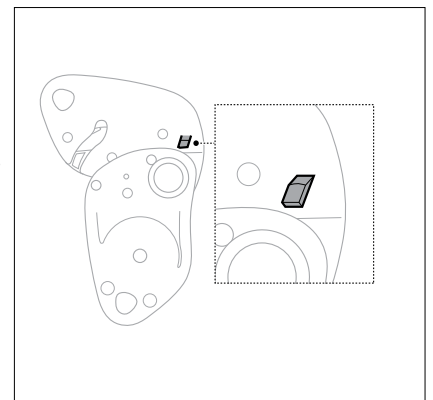

- Verify that the moving side plate opens and closes properly

- Check the condition and function of the locking system (marks, deformation, effectiveness of the return spring).

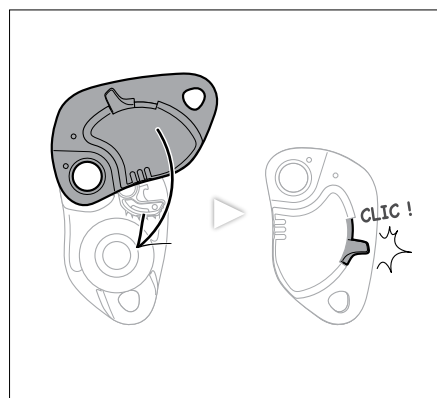
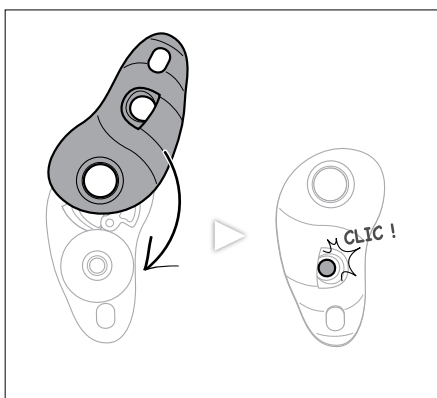

#### 4. Checking the attachment holes and the fixed side plate

- Check the condition of the anchor attachment hole (marks, deformation, cracks, corrosion)

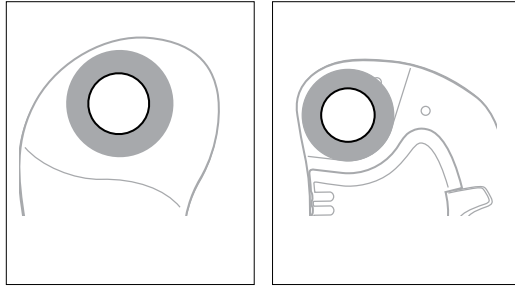

- Check the condition of the fixed side plate (marks, deformation, cracks, corrosion).

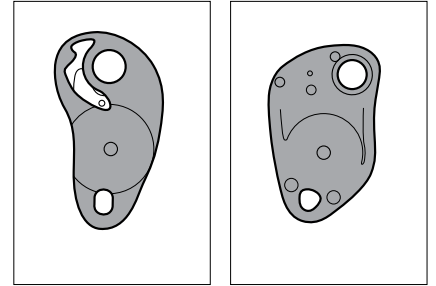

- Check the condition of the secondary attachment hole (marks, deformation, cracks, corrosion)

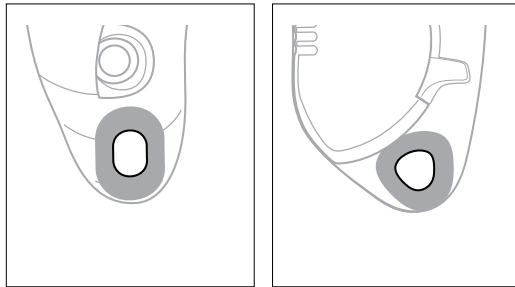

- With the device in the locked position, check the alignment of the side plates at the secondary attachment hole.

- Check the condition of the rivets (marks, deformation, cracks, corrosion, absence of play...).

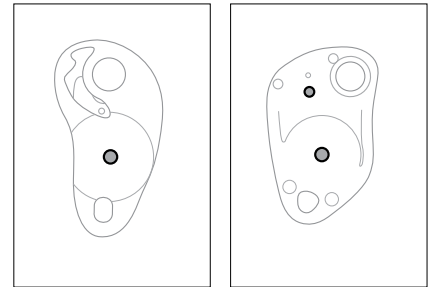

#### 5. Checking the cam

- Check the condition of the cam (marks, deformation, cracks, corrosion)  
Check that all teeth are present and check their state of wear.  
The teeth must not be fouled. If necessary, clean them with a brush.

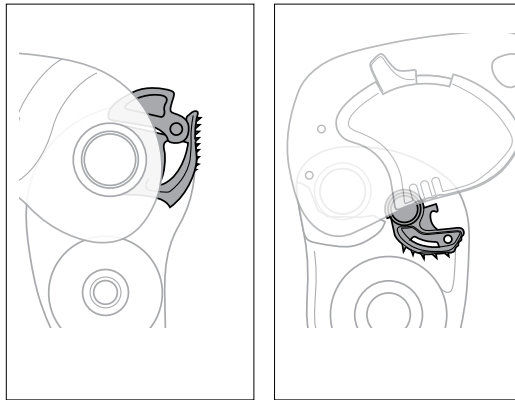

- Check the cam's rotation and the effectiveness of the return spring.

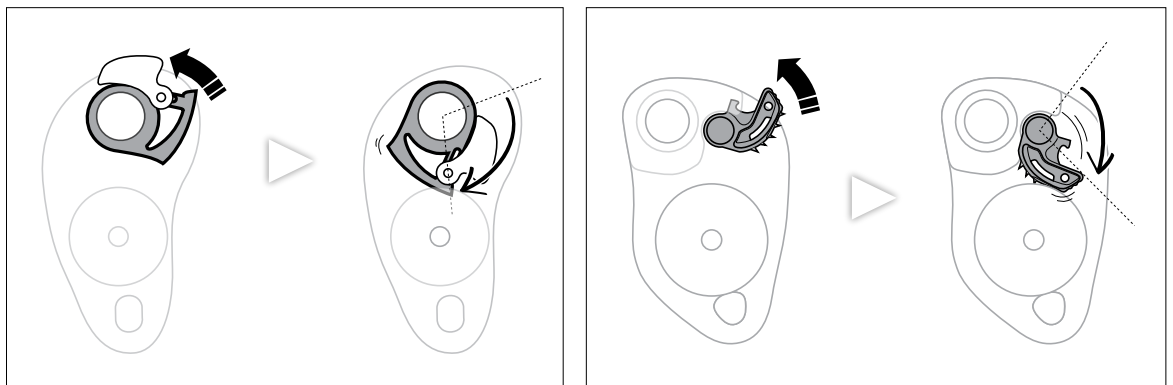

## 5. Checking the cam

- Verify that the cam-locking system works properly (red latch for P51; button for P51A).

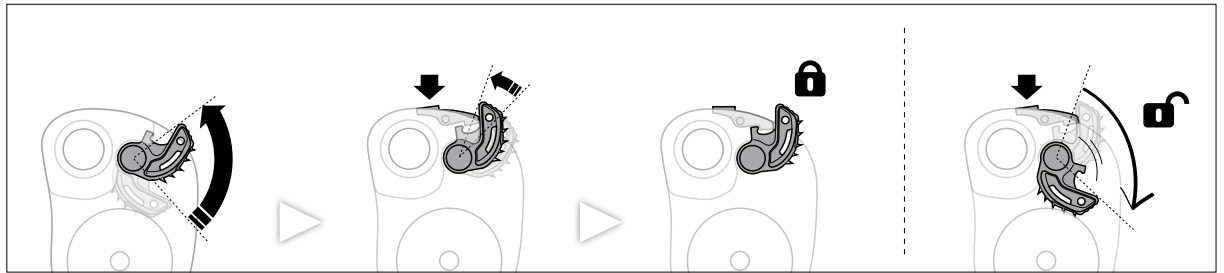
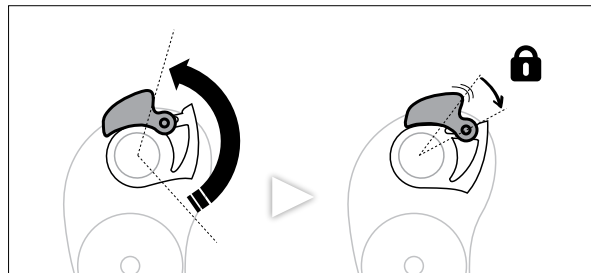

## 6. Checking the sheave

- Check the condition of the sheave (marks, deformation, corrosion, absence of foreign bodies...).

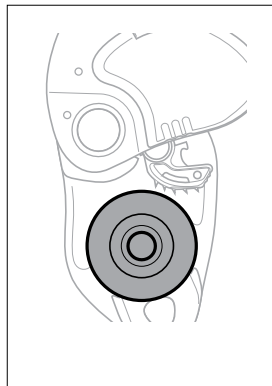
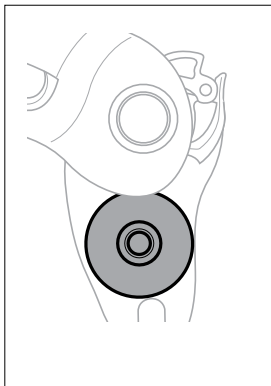

- Verify that the sheave turns freely.

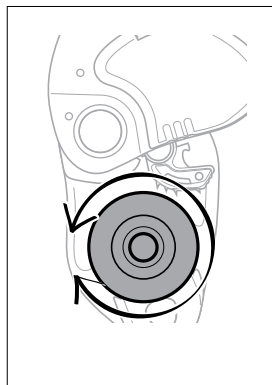
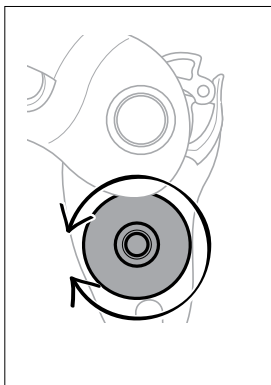

## 7. Function check

Install your pulley on an anchor and install a compatible rope around the sheave.

- With the cam deactivated, circulate the rope in both directions.

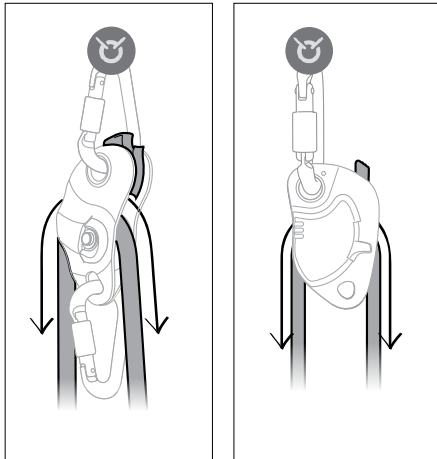

- With the cam activated, make sure the rope circulates in one direction and locks in the other direction.

