

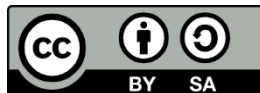

EdBuild

Let's build the EdPrinter

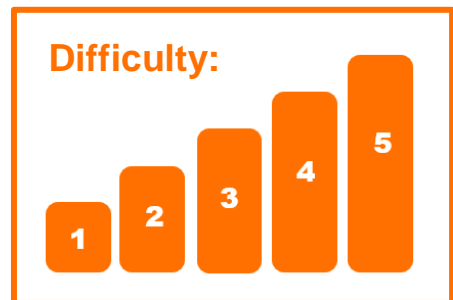
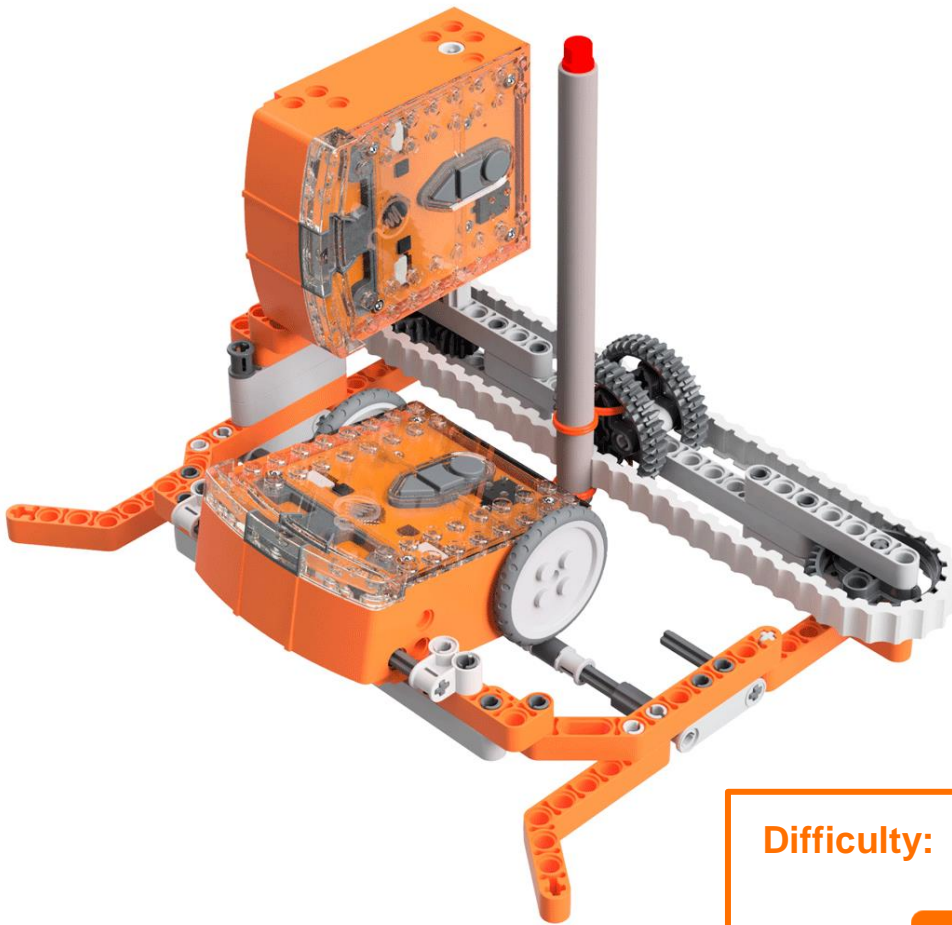

The EdPrinter EdBuild by [Microbric Education](#) is licensed under a [Creative Commons Attribution-ShareAlike 4.0 International License](#).

EdBuild – the EdPrinter

The EdPrinter is a pen plotter which can be programmed to draw a range of different shapes using EdPy. This guide includes the share links to the official base programs for the EdPrinter, with which you will be able to draw a rectangle. You will then be able to use the base programs to draw other shapes with the EdPrinter.

Build difficulty rating

The EdPrinter is rated a level 5 build.

Difficulty rating	Recommended age	Programming skills needed
1	8+	- Barcodes and remote control
2	8+	- Barcodes and remote control
3	8+	- Barcodes and remote control
4	10+	- Barcodes and remote control AND - EdWare OR - EdPy
5	12+	- EdPy

To successfully complete and operate a build, you will need an understanding of the programming skills listed.

Learn more about programming with Edison at:

- **Barcodes:** Appropriate for ages 4+. No prior experience with programming or robotics is assumed or required.
www.meetedison.com/robot-activities/youre-a-controller/
- **EdWare:** Best suited to students aged 11 to 13. A basic understanding of programming fundamentals may be helpful.
www.meetedison.com/robot-programming-software/edware/
- **EdPy:** Best suited to students aged 13 to 16 years old. A basic understanding of programming fundamentals may be helpful.
www.meetedison.com/robot-programming-software/edpy/

Get set up

Before you begin this build, check that you have everything you need and that you can do the programming required. It's also a good idea to get familiar with how to build with your Edison robot.

What you need

To make the EdPrinter, you will need:

- 2 Edison robots
- 1 EdCreate – Edison robot creator's kit
- 1 felt-tip pen, marker or coloured pencil
- Paper (see dimensions below)

The EdPrinter works best with a writing utensil that writes with low pressure, such as a felt-tip pen or marker. You can also use a coloured pencil, so long as the pencil's lead is fairly soft.

Paper is loaded into the interior frame base of the EdPrinter, which is approximately 15cm wide. Standard A5 paper (14.8cm x 21cm) works well in the EdPrinter. Standard USA letter sized paper (8.5 inches x 11 inches) or A4 paper (21cm x 29.7cm) halved width-wise will also work. Standard-weight (80-150 GSM) copy paper works best with the EdPrinter.

Programming required in this build

To program the EdPrinter, you will need to program the Edison robots using the EdPy robotic programming language. Links to the programs you need are provided in this guide.

Building with Edison



You can build with Edison using an EdCreate creator's kit or any other LEGO brick compatible building system.

Bricks can be attached to the top and bottom of your Edison robot. Pegs can be attached on the sides of Edison. When Edison's wheels are removed, cross axles can be used in the powered sockets.

There are three types of holes on the side of Edison: pin holes, stud holes, and cross axle sockets. Look at the following images to learn more about how to connect and build with Edison.

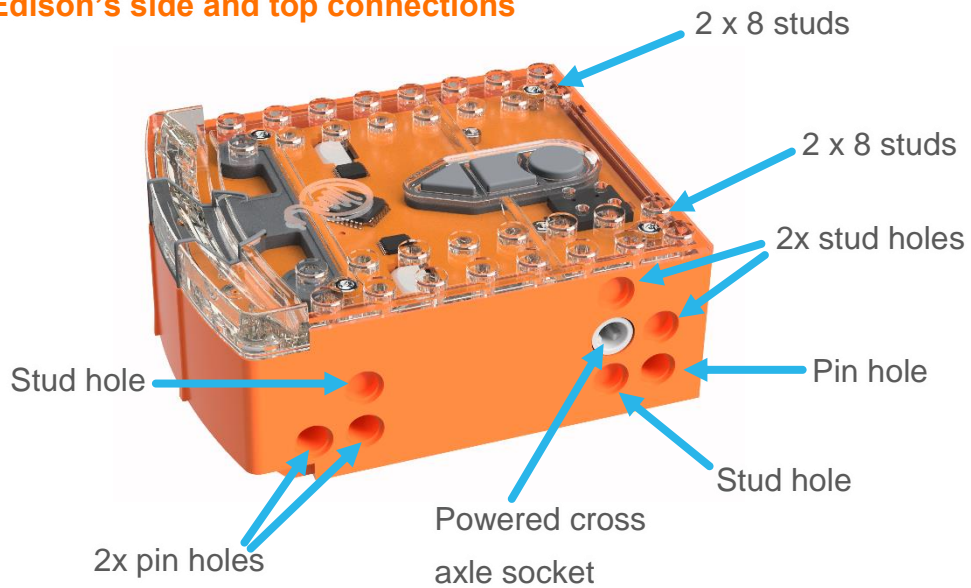
Edison's side and top connections



Hole type	Description	Connects to
Pin hole	A full-depth hole for connecting pegs.	
Stud hole	A hole of normal stud-depth which works with half pegs.	
Cross axle socket	A powered socket which rotates.	

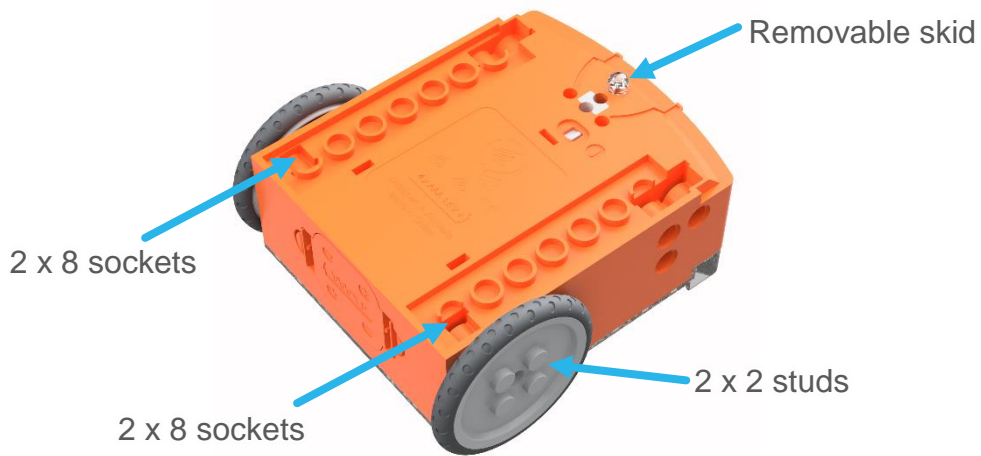

Edison's bottom and wheel connections

Let's build the EdPrinter!

The EdPrinter is a pen plotter which is run using two Edison robots programmed using EdPy. By attaching a writing utensil, such as a felt-tip pen, to the EdPrinter and using a set of basic functions in EdPy, you will be able to program the EdPrinter to draw a range of different shapes.

This is what the finished EdPrinter, with attached pen, looks like:

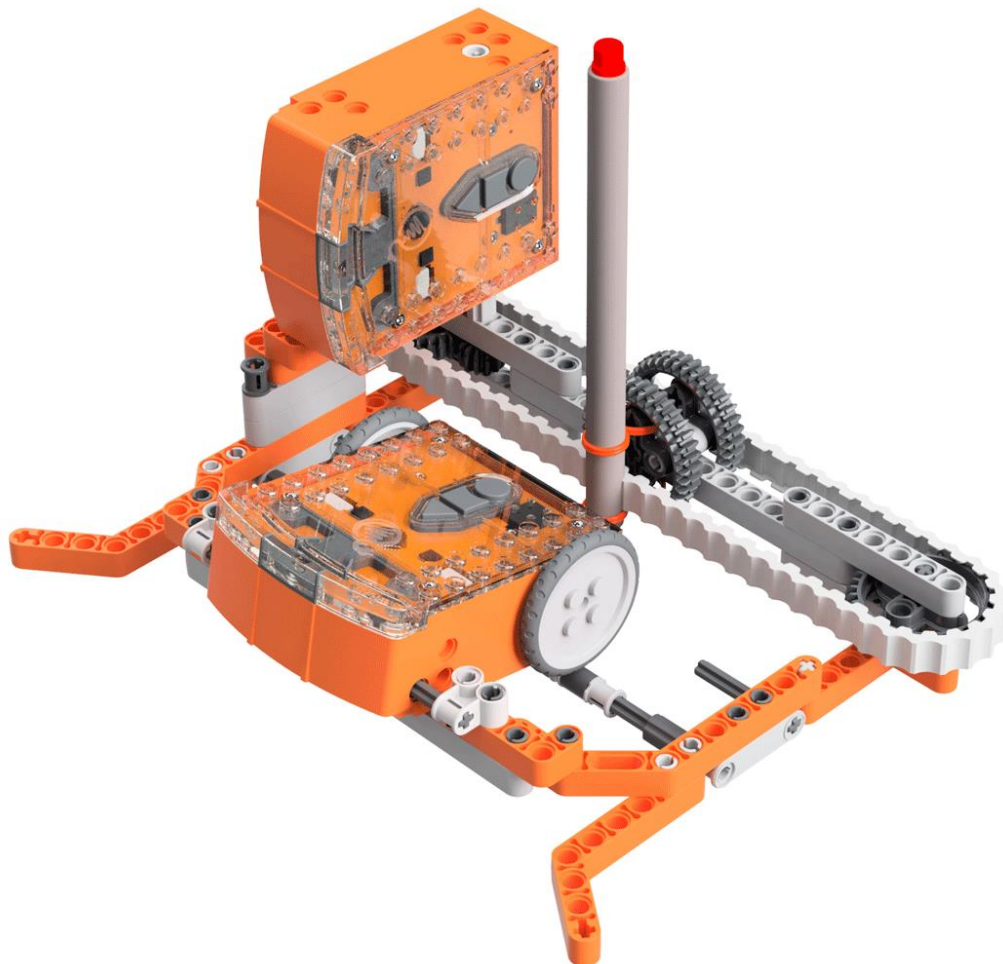

Step 1: Understand how the EdPrinter programs work

Both of the Edison robots used in the EdPrinter will need to be programmed using EdPy. You can download the programs into the robots before or after you build the EdPrinter.

To be able to use the EdPrinter, it is important to understand how the two Edison robots in the EdPrinter work.

Look at the image above. The Edison on its side attached to the belt in the pen-control Edison. The other Edison, with its wheels attached, is the paper-control Edison.

Programming Edison – downloading the base programs

You can download both the paper-controlling robot base program and the pen-controlling robot base program using EdPy, available at www.edpyapp.com

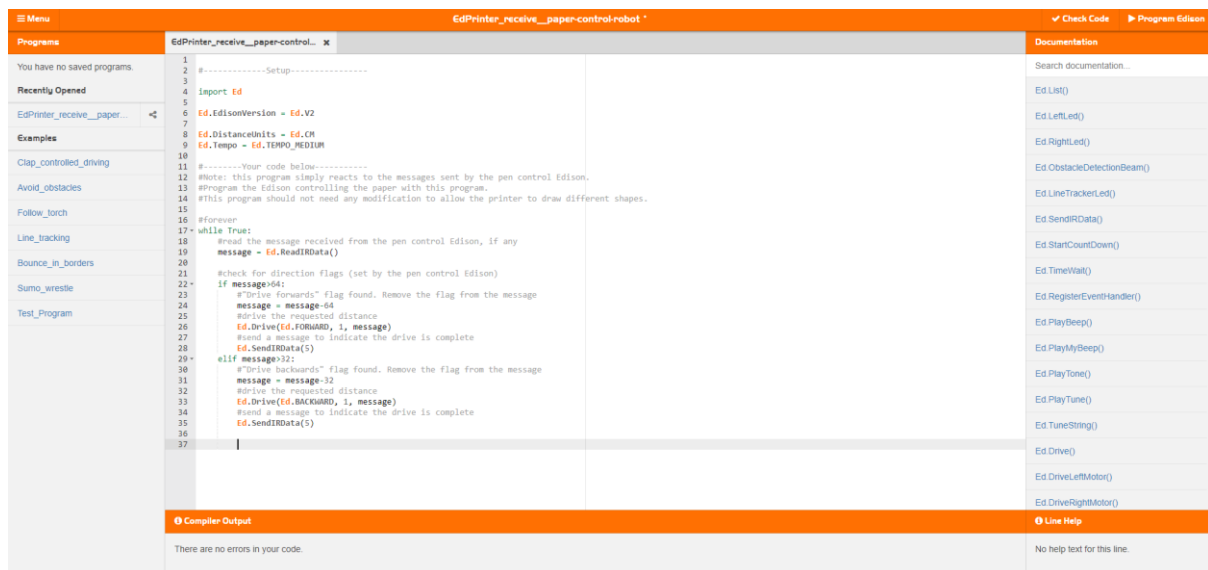

```
1 #-----Setup-----
2
3
4 import Ed
5
6 Ed.EdisonVersion = Ed.V2
7
8 Ed.DistanceInits = Ed.CM
9 Ed.Tempo = Ed.TEMPO_MEDIUM
10
11 #-----Your code below-----
12 #Note: this program simply reacts to the messages sent by the pen control Edison.
13 #Program the Edison controlling the paper with this program.
14 #This program should not need any modification to allow the printer to draw different shapes.
15
16 #Forever
17 while True:
18     #read the message received from the pen control Edison, if any
19     message = Ed.ReadIRData()
20
21     #check for direction flags (set by the pen control Edison)
22     if message>0:
23         #Drive forwards" flag found. Remove the flag from the message
24         message = message-04
25         #Drive the requested distance
26         Ed.Drive(Ed.FORWARD, 1, message)
27         #send a message to indicate the drive is complete
28         Ed.SendIRData(5)
29     elif message>32:
30         #Drive backwards" flag found. Remove the flag from the message
31         message = message-32
32         #Drive the requested distance
33         Ed.Drive(Ed.BACKWARD, 1, message)
34         #send a message to indicate the drive is complete
35         Ed.SendIRData(5)
36
37
```

Paper-controlling robot

The paper-controlling robot is the robot which sits with its wheels on the paper. This robot is reactionary – it receives and follows the instructions from the pen-controlling robot.

Use the share code www.edpyapp.com/share/oLn1L to open the official EdPrinter paper-controlling robot program in EdPy. You can download this program as-is into this Edison robot.

You can use this program as-is for any EdPrinter programs. To make your own EdPrinter programs, change the pen-controlling robot program as described below.

Pen-controlling robot

The pen-controlling robot is the robot which moves the belt with the pen attached. This robot is the main driver of the EdPrinter.

Use the share code www.edpyapp.com/share/GzSRI to open the official EdPrinter pen-controlling program in EdPy. You can download this program as-is into your Edison robot. When you run the program in conjunction with the paper-control Edison robot program above you will draw a rectangle with the EdPrinter.

The pen-control base program contains a set of basic functions for controlling the EdPrinter in order to draw lines in four directions: to the right, to the left, to the front and to the back. By rearranging the order in which these functions are called and adjusting the value of the input variable, you can create your own EdPrinter programs.

Step 2: Assemble the EdPrinter

Follow the illustrations step by step to build the EdPrinter.

Reading the instructions:

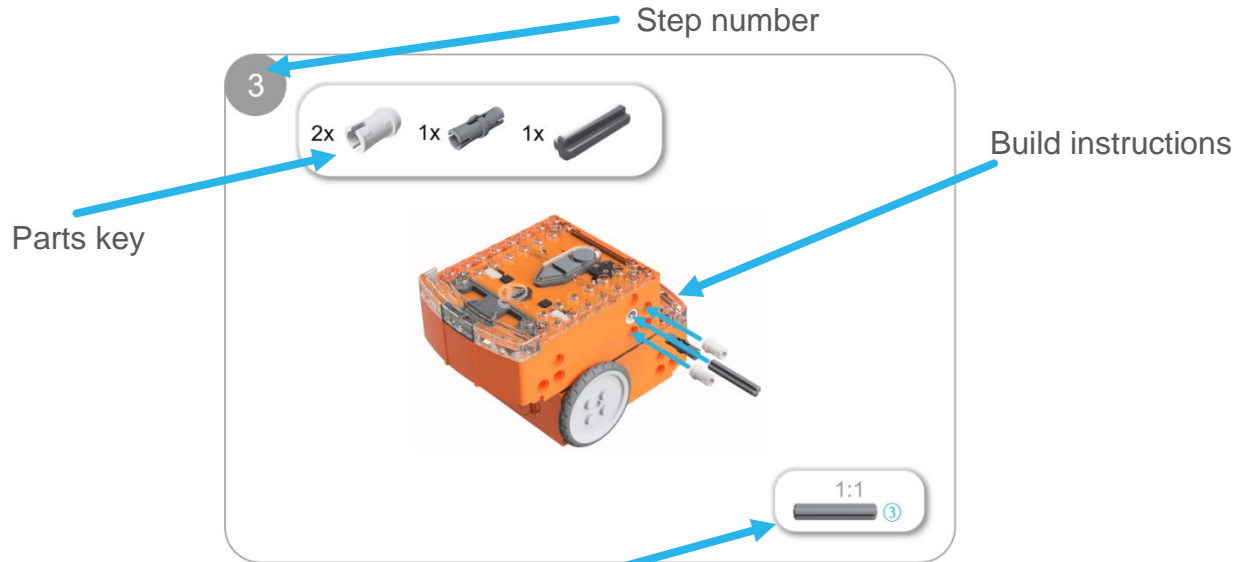

One-to-one piece measurement (when printed at 100% on A4 page). The number in the circle indicates the part's length in number of studs.

Inserting paper into the EdPrinter

Once the printer is fully assembled, you will need to insert paper into the base of the printer. Insert the paper into the bottom of the EdPrinter frame, as follows:

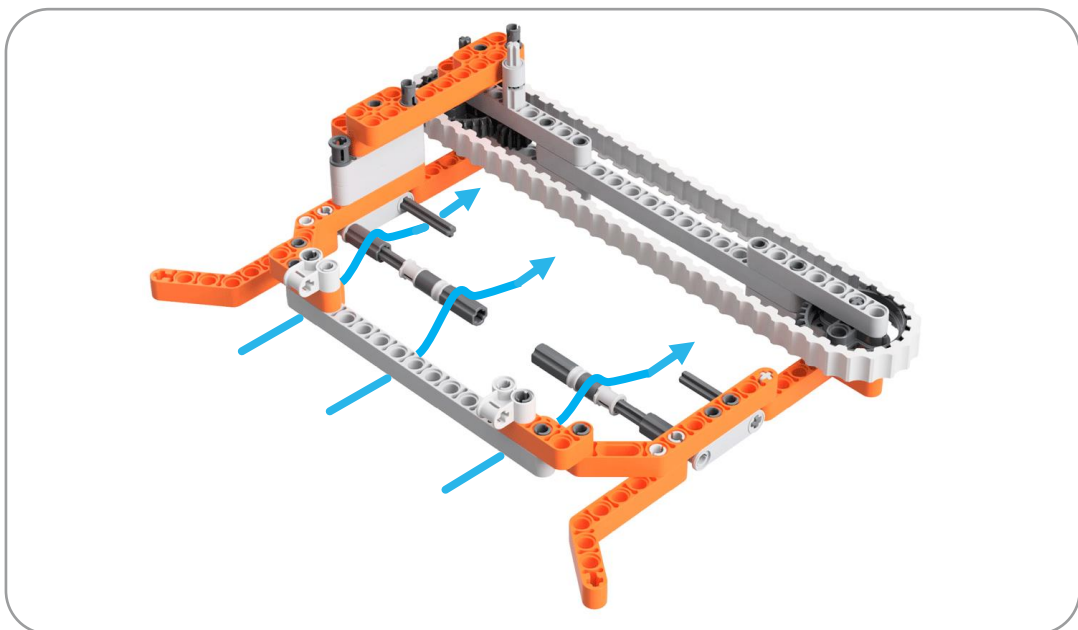

The paper should first go under the front grey beam. It then needs to go over the longer set of bars with the rollers attached. The paper should sit between these rollers and the paper-controlling Edison's wheels. Finally, the paper should be slid under the short set of axles protruding from the frame of the EdPrinter. These axles keep the paper in place.

Be sure to push the paper back so that the pen sits on the paper. The EdPrinter works best if at least 3cm of paper extends back beyond the pen.

Operating the EdPrinter

To operate the EdPrinter, be sure that:

- The EdPrinter is fully assembled
- The pen is at the correct starting point on the belt for your program (e.g. fully to the left end, closest to the pen-controlling Edison)
- Both Edison robots are turned on and each has the correct program downloaded
- Paper is correctly loaded into the EdPrinter base.

Press the play (triangle) button on the paper-control Edison robot first. Then press the play (triangle) button on the pen-control Edison robot second. This will run the program and draw your shape.

1

2x



2x



2x

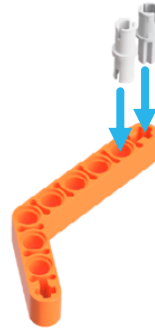

2

2x

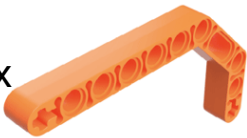

2x



2x



2x

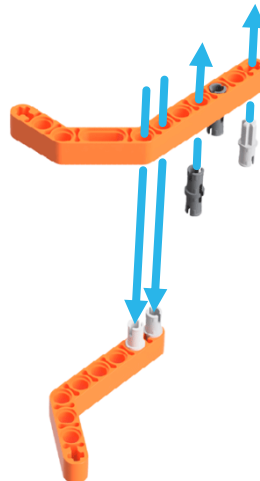

3

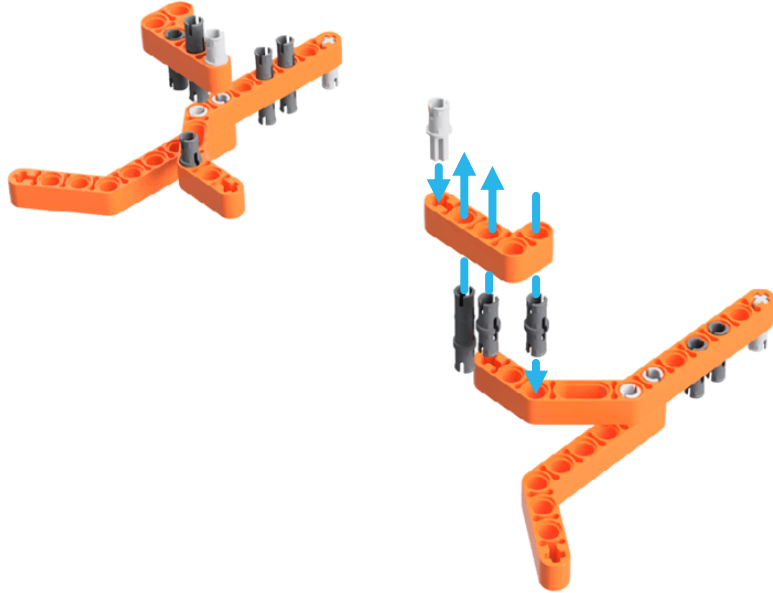

4

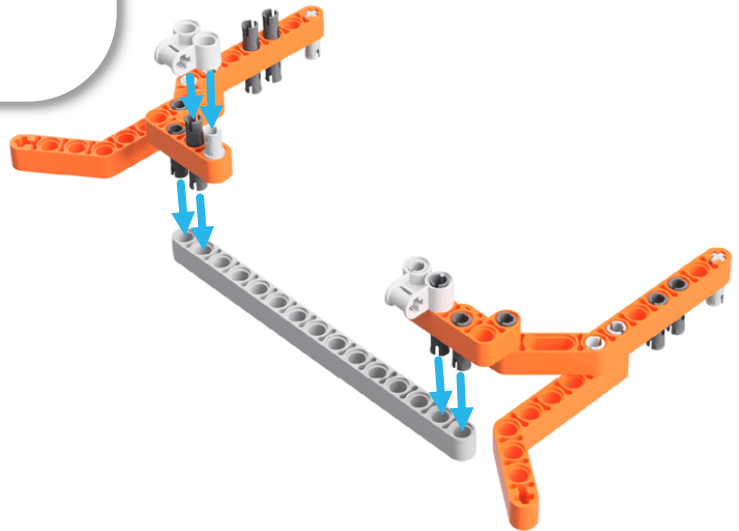
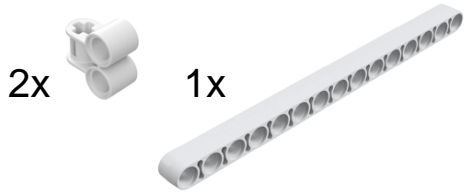

1:1



5

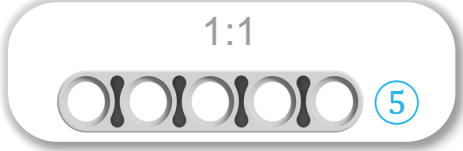
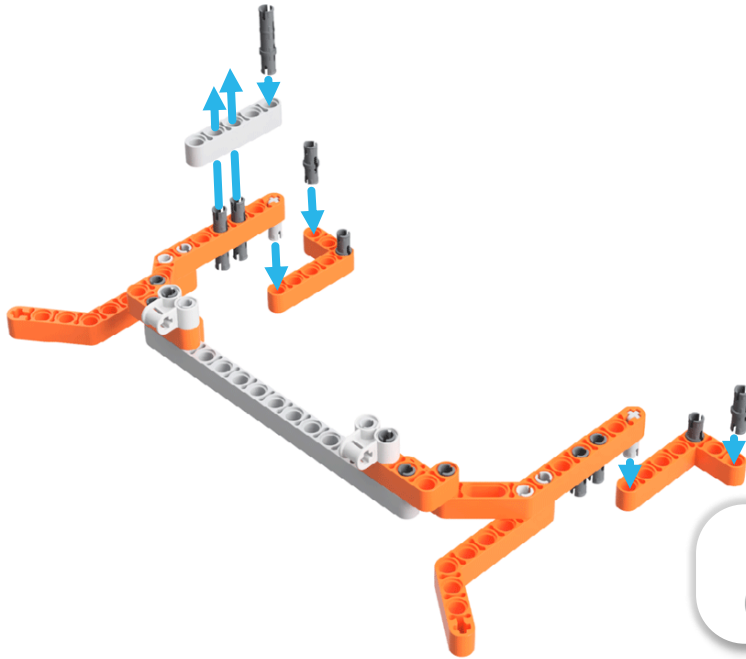

6

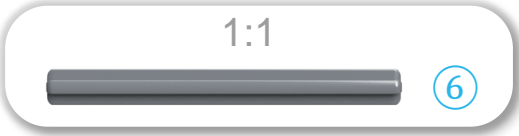

7

2x

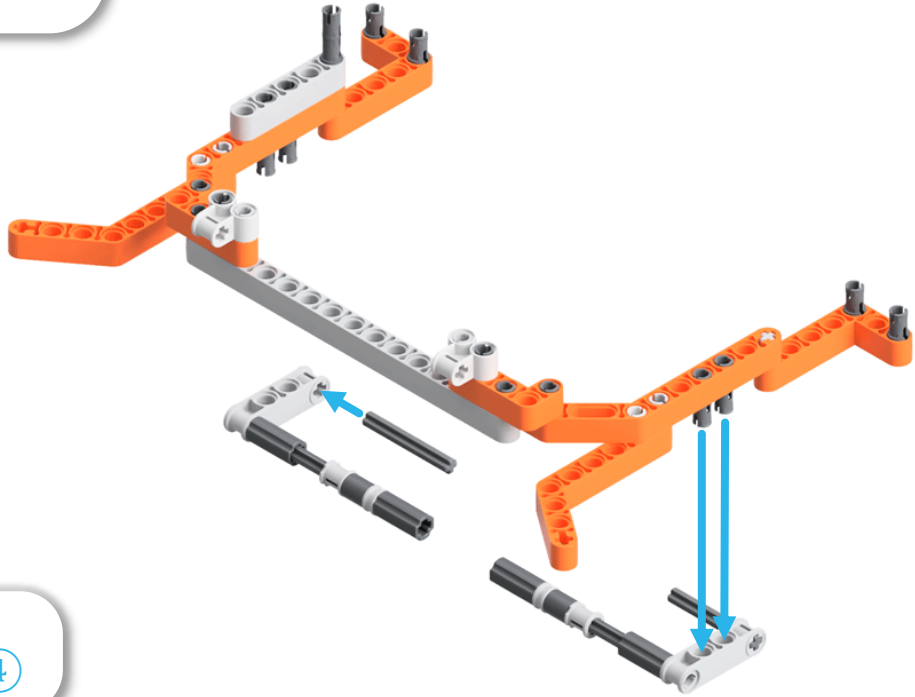
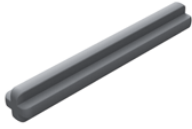

1:1



4

8

1x



1x

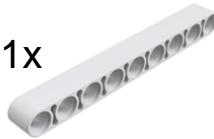

1x

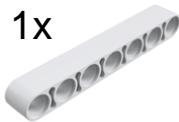

4x

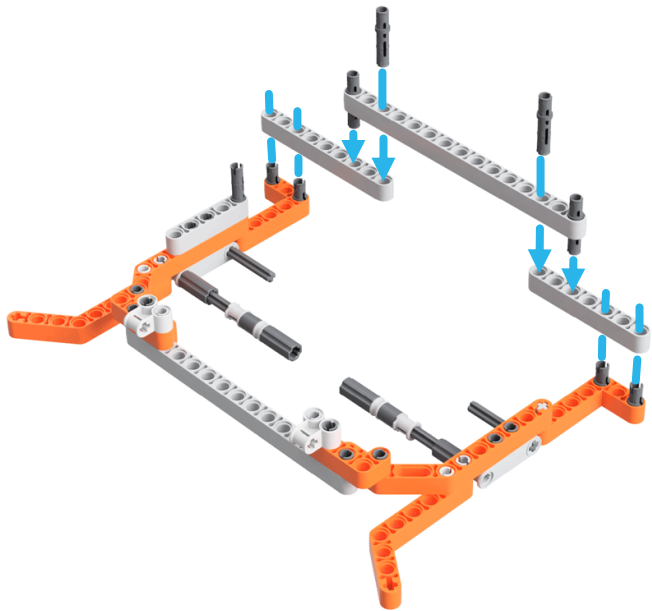

1:1



7



9



15

9

1x

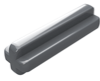

1x

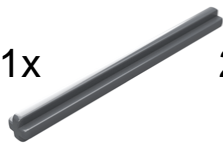

2x

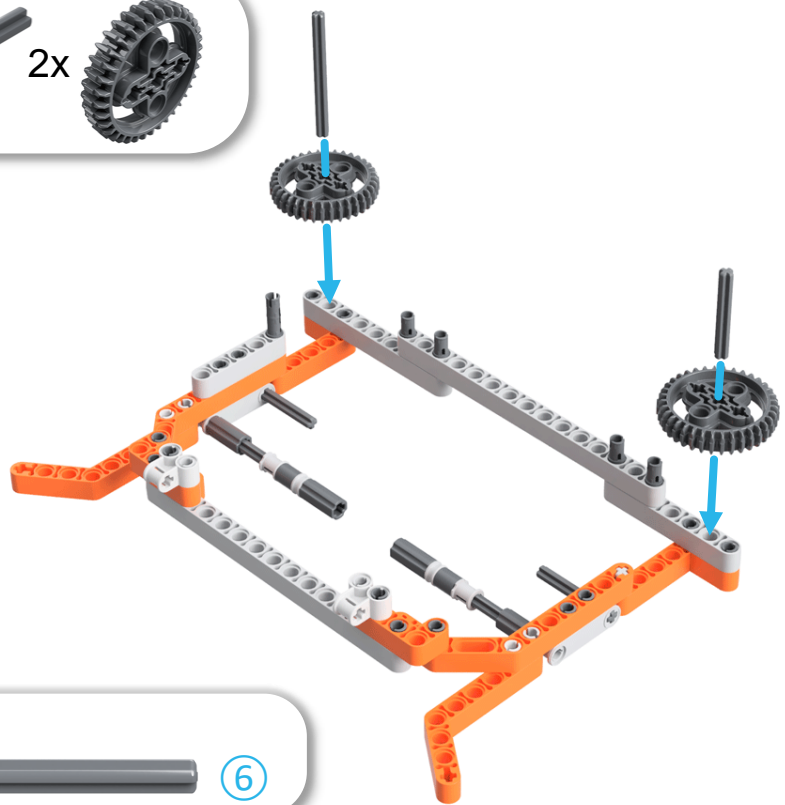

1:1



3



6

10

1x



1x



1x



1x



1x



1x



1x

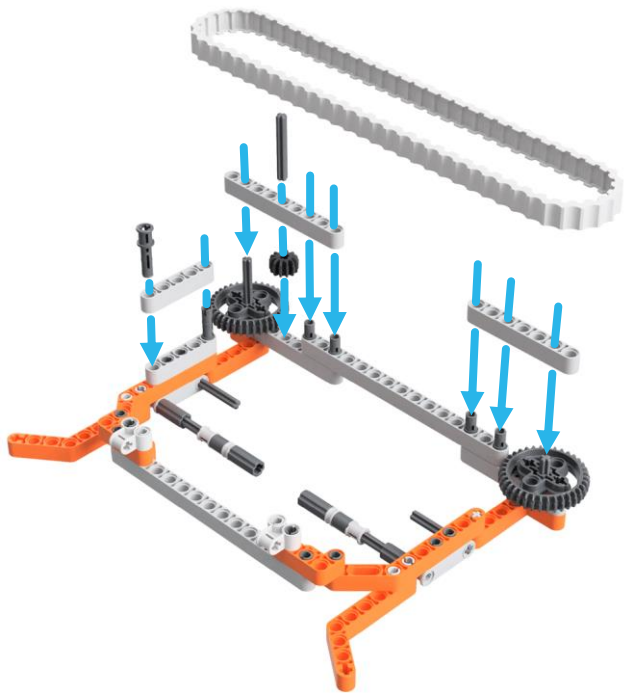
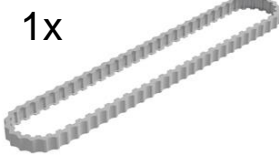

7

1:1



4



9



5

11

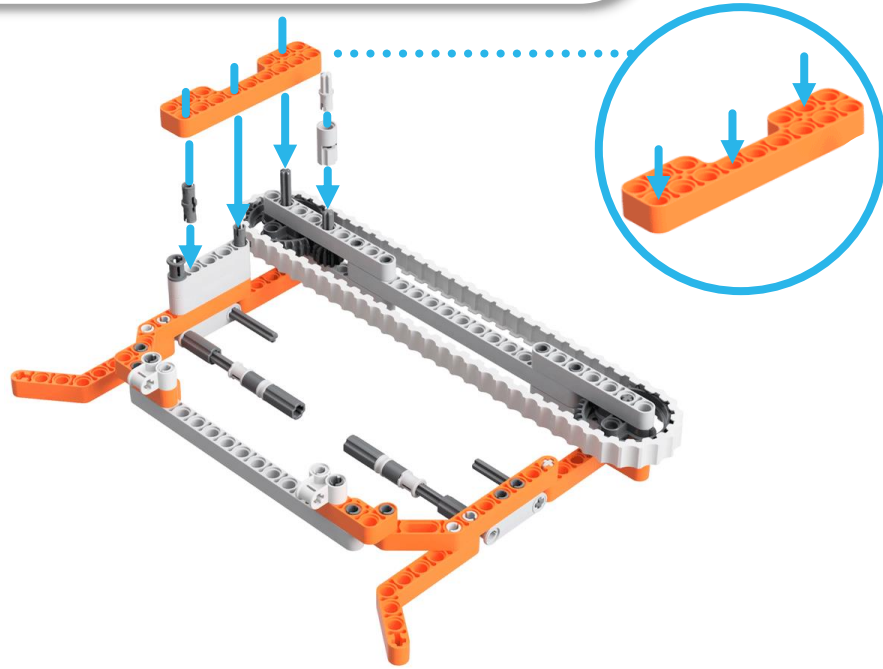

12

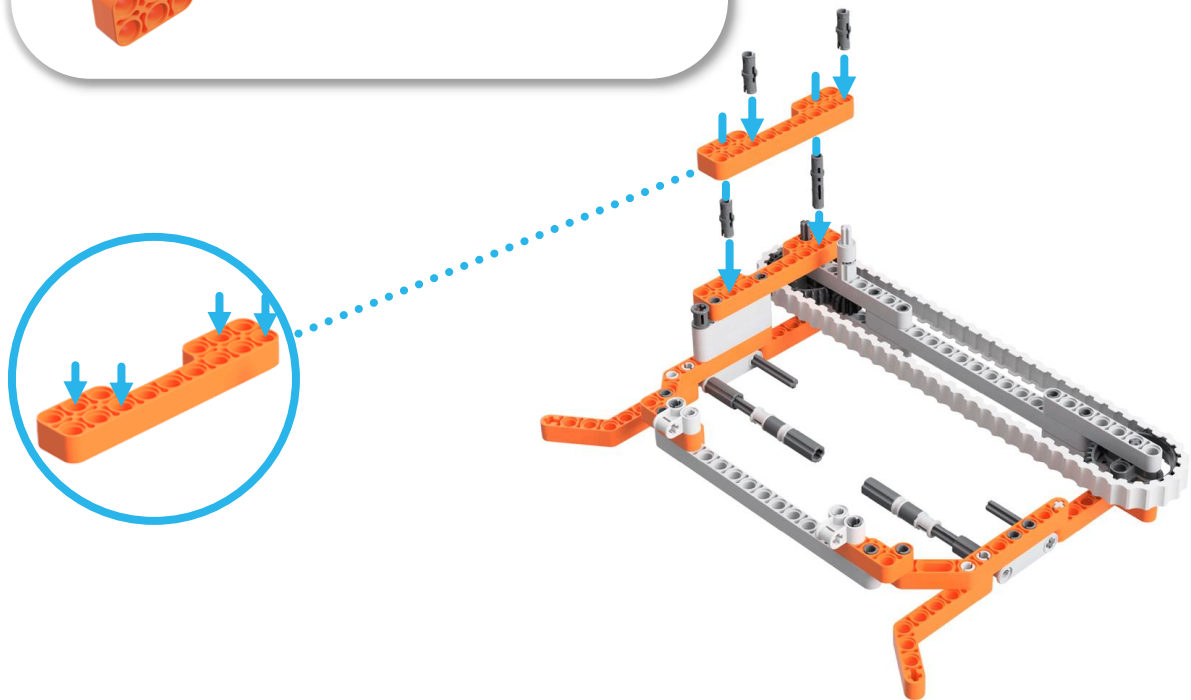
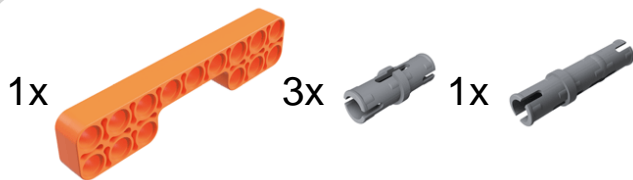

13

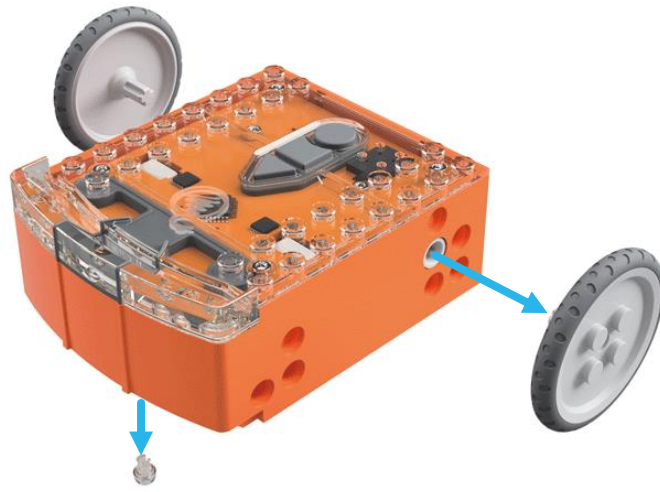

14

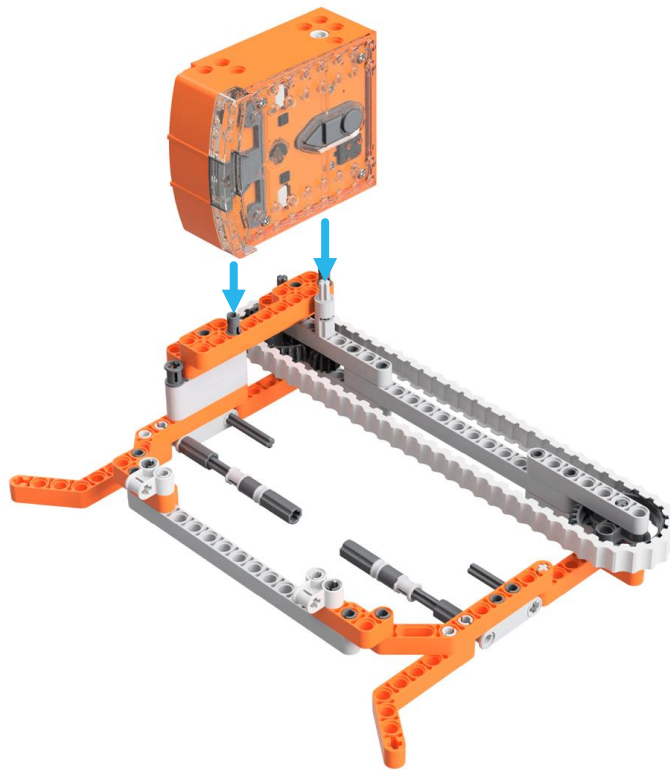

15

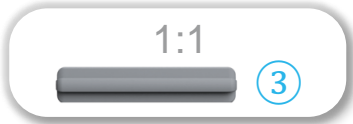

16

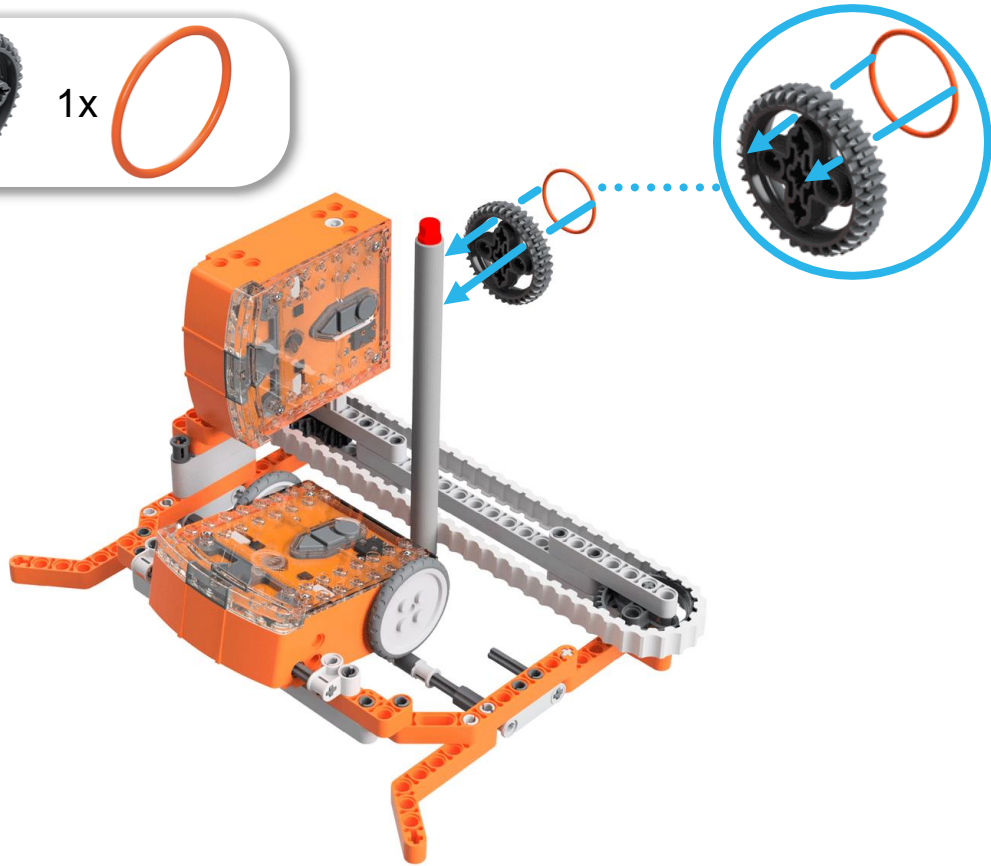

17

1x

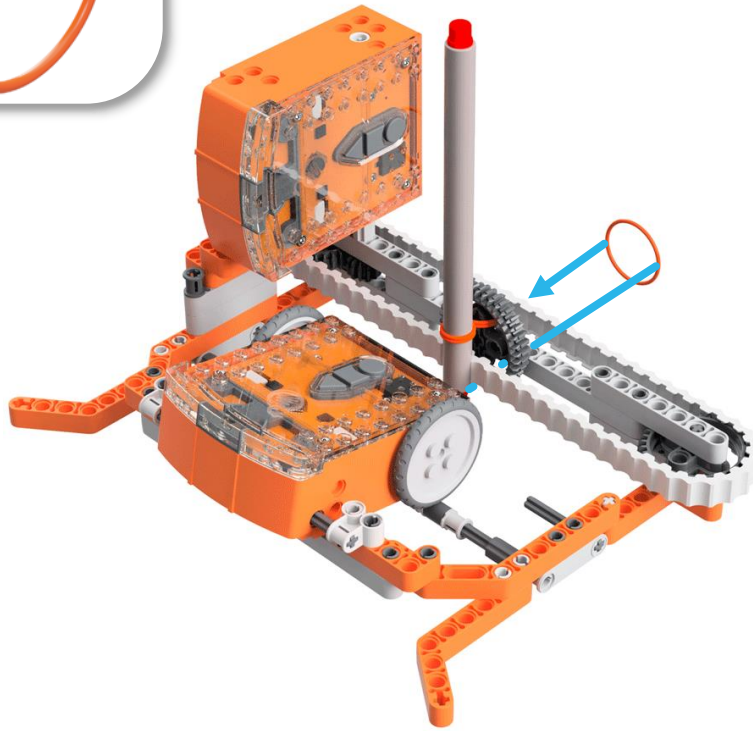

18

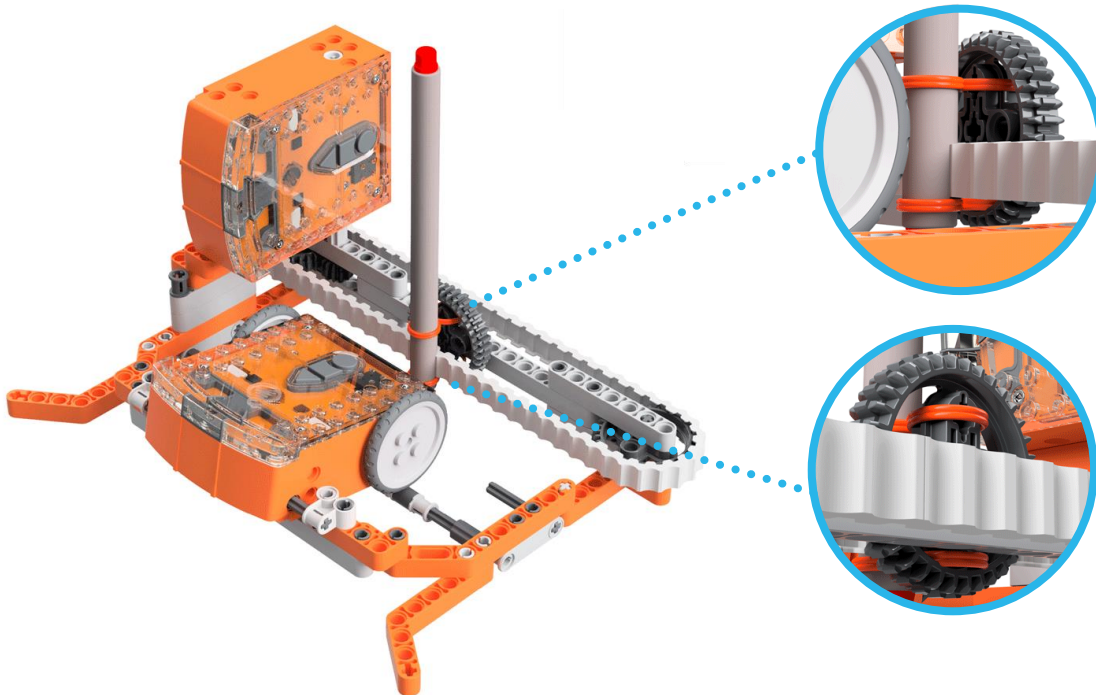

19

1x



4x

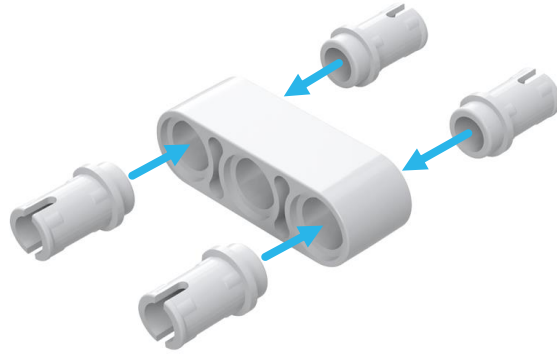

1:1



3

20

1x

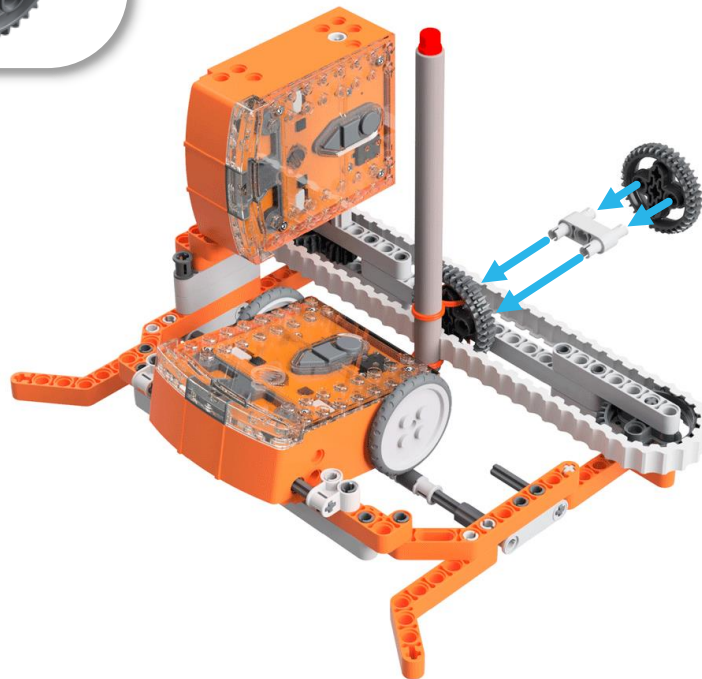

21

