

The MEYER 2/1 Pallet Handler with the unique encapsulated Shaft Guide Concept provides an optimum of visibility and clean working environment. The high working speed with synchronised fork travel and separate sideshift function allow for a safe, ergonomic and efficient operation. The interchangeable bolt-on forks are hydraulically operated from the drivers position. Many special designs, such as customized load backrests, load stabilizers or an additional load extension are available.

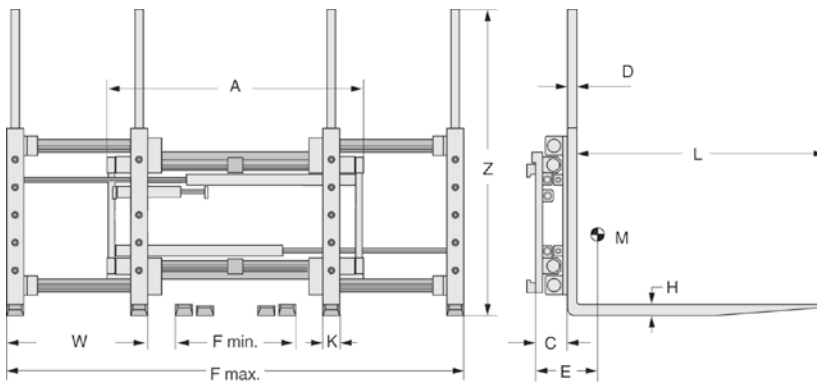



**Range:** 1600 kg - 6000 kg

**Plus:**

- Single/double pallet handler for handling one or two pallets.
- Excellent visibility through the body.
- Separate sideshift provides constant sideshift range regardless of the fork opening.
- Synchronized fork movement with flow divider valve.
- Gas-spring operated inner fork positioning.
- Incorporated load backrests.
- Bolt-on forks with specially reinforced heel area.

**Video** (press the Icon)

**Multi Pallet Handler - Shaft Guide Concept** (press the Icon)

Model	Capacity	Load centre	for FLT capacity max.	Chassis width	Sideshift per side	Opening range	Load guard height	Fork section	Fork spread	Fork length	Fork upright	Lic	Cog	Weight	Mounting class
a 6-5203G	1.600	600	2,0/600	1.100	100	550-1730	1.350	80x40	490	1.150	40	192	232	512	2 A
b 6-5203G	1.600	600	2,0/600	1.100	100	550-1730	1.350	80x30	490	1.150	40	192	230	497	2 A
a 6-5204G	2.200	600	2,5/600	1.200	100	550-1930	1.350	80x40	540	1.150	40	192	231	525	2 A
b 6-5204G	2.200	600	2,5/600	1.300	100	550-2030	1.350	80x40	540	1.150	40	192	231	532	2 A
c 6-5204G	2.200	600	2,5/600	1.300	100	650-2030	1.350	80x40	590	1.150	40	192	231	535	2 A
a 6-5205G	2.200	600	3,0/500	1.200	100	550-1930	1.350	80x40	540	1.150	40	172	243	518	3 A
b 6-5205G	2.200	600	3,0/500	1.300	100	550-2030	1.350	80x40	540	1.150	40	172	243	525	3 A
c 6-5205G	2.200	600	3,0/500	1.300	100	650-2030	1.350	80x40	590	1.150	40	172	243	530	3 A
a 6-5206G	2.600	600	3,5/500	1.200	100	550-1930	1.350	80x50	540	1.150	50	172	243	558	3 A
b 6-5206G	2.600	600	3,5/500	1.300	100	550-2030	1.350	80x50	540	1.150	50	172	243	565	3 A
c 6-5206G	2.600	600	3,5/500	1.300	100	650-2030	1.350	80x50	590	1.150	50	172	243	570	3 A
a 6-5207F	3.200	600	4,0/500	1.200	100	550-1930	1.350	80x60	550	1.150	60	157	230	670	3 A
b 6-5207F	3.200	600	4,0/500	1.300	100	550-2030	1.350	80x60	550	1.150	60	157	230	677	3 A
c 6-5207F	3.200	600	4,0/500	1.300	100	650-2030	1.350	80x60	600	1.150	60	157	230	682	3 A
a 6-5208F	4.200	600	5,0/600	1.310	100	540-1920	1.350	80x60	540	1.150	60	184	218	783	3 A
b 6-5208F	4.200	600	5,0/600	1.410	100	540-2020	1.350	80x60	540	1.150	60	184	218	795	3 A
c 6-5208F	4.200	600	5,0/600	1.410	100	640-2020	1.350	80x60	590	1.150	60	184	218	805	3 A
a 6-5210F	5.000	600	5,0/600	1.410	100	540-2020	1.350	80x60	540	1.150	60	184	225	850	4 A
a 6-5212N	6.000	600	8,0/600	1.420	160	560-1960	1.350	80x75/100x70	560	1.150	70	244	258	1.235	4 A

**Notes:**

Additional hydraulics required: - two.

- The unit has a separate sideshift.
- Equipped with high quality bolt-on forks.
- Types 6-5203G, 04G, 05G, 06G, 07F, 08F and 10F with interchangeable forks.
- Minimum carriage width of truck:
 

6-5203G - 06G / 07F	980 mm
6-5208F/10F	1100 mm
6-5212N	1640 mm

**Options:**

- Alternative fork lengths and fork section.
- Extending 2/1 pallet fork.
- Special load backrest.
- Forks on one level.
- Design with load stabilizer.
- Quick disconnect lower hooks.
- Automatic lubrication system.
- Micro cylinders instead of gas spring.

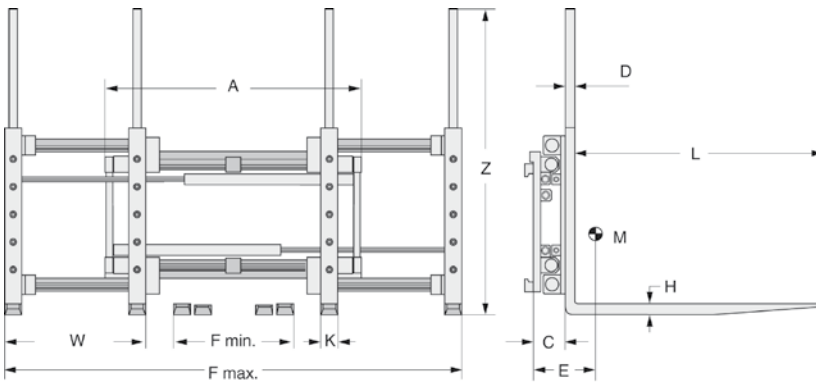

**Range:** 1600 kg - 5000 kg

**Plus:**

- Single/double pallet handler for handling one or two pallets.
- Excellent visibility through the body.
- Synchronized fork movement with flow divider valved.
- Gas-spring operated inner fork positioning.
- Incorporated load backrests.
- Bolt-on forks with specially reinforced heel area.

 **Video** (press the icon)

 **Multi Pallet Handler - Shaft Guide Concept** (press the icon)

Model	Capacity		Load centre for FLT capacity max.	Chassis width	Opening range	Load guard height	Fork section	Fork spread	Fork length	Fork upright	Lic	Cog	Weight	Mounting class
	Q kg	LSP mm												
6-6703G	1600	600	2,0/600	1100	550-1730	1350	80x40	490	1150	40	192	232	509	2 A
6-6703G	1600	600	2,0/600	1100	550-1730	1350	80x30	490	1150	40	192	230	494	2 A
6-6704G	2200	600	2,5/600	1200	550-1930	1350	80x40	540	1150	40	192	231	522	2 A
6-6704G	2200	600	2,5/600	1300	550-2030	1350	80x40	540	1150	40	192	231	529	2 A
6-6704G	2200	600	2,5/600	1300	650-2030	1350	80x40	590	1150	40	192	231	532	2 A
6-6705G	2200	600	3,0/500	1200	550-1930	1350	80x40	540	1150	40	172	243	513	3 A
6-6705G	2200	600	3,0/500	1300	550-2030	1350	80x40	540	1150	40	172	243	520	3 A
6-6705G	2200	600	3,0/500	1300	650-2030	1350	80x40	590	1150	40	172	243	525	3 A
6-6706G	2600	600	3,5/500	1200	550-1930	1350	80x50	540	1150	50	172	243	553	3 A
6-6706G	2600	600	3,5/500	1300	550-2030	1350	80x50	540	1150	50	172	243	560	3 A
6-6706G	2600	600	3,5/500	1300	650-2030	1350	80x50	590	1150	50	172	243	565	3 A
6-6707M	3200	600	4,0/500	1200	550-1930	1350	80x60	550	1150	60	152	226	655	3 A
6-6707M	3200	600	4,0/500	1300	550-2030	1350	80x60	550	1150	60	152	226	662	3 A
6-6707M	3200	600	4,0/500	1300	650-2030	1350	80x60	600	1150	60	152	226	667	3 A
6-6708F	4200	600	5,0/600	1310	540-1920	1350	80x60	540	1150	60	184	220	775	3 A
6-6708F	4200	600	5,0/600	1410	540-2020	1350	80x60	540	1150	60	184	220	790	3 A
6-6708F	4200	600	5,0/600	1410	640-2020	1350	80x60	590	1150	60	184	220	800	3 A
6-6710F	5000	600	5,0/600	1410	540-2020	1350	80x60	540	1150	60	184	210	830	4 A

**Notes:**

- Additional hydraulics required: - one.
- Equipped with high quality bolt-on forks.
- Types 6-6703G, 04G, 05G, 06G, 07M, 08F and 10F with interchangeable forks.
- Minimum carriage width of truck:  
 6-6703G - 07M                      980 mm  
 6-6708F / 10F                      1100 mm
- The 1-2 pallet handler can be fitted to any sideshift already existing on the truck.

**Options:**

- Alternative fork lengths and fork section.
- Extending 2/1 pallet fork.
- Special load backrest.
- Forks on one level.
- Design with load stabilizer.
- Quick disconnect lower hooks.
- Automatic lubrication system.
- Micro cylinders instead of gas spring.

**Range:** 1200 kg - 2000 kg

**Plus:**

- The MEYER load-extending pallet handlers enables loading and unloading from one side of the road vehicle (further characteristics and function as the 2/1 and 3/2/1 pallet clamps).

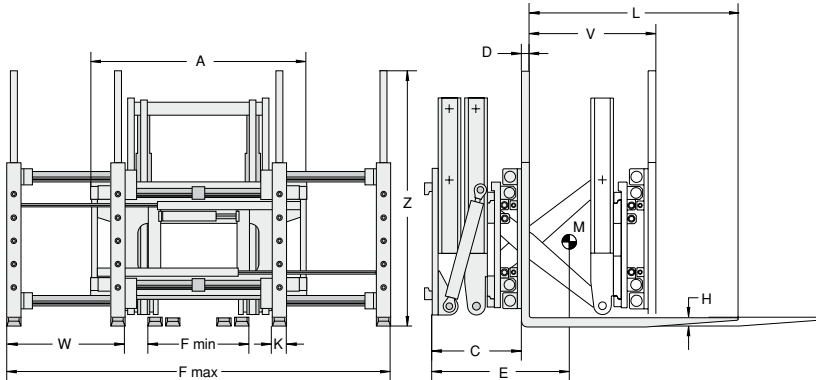

**Multi Pallet Handler - Shaft Guide Concept** (press the icon)

Model	Capacity	Load centre	for FLT capacity max.	Chassis width	Sideshift per side	Opening range	Load guard height	Fork section	Fork spread	Fork length	extension	Fork upright	L/c	Cog	Weight	Mounting class
	Q kg	LSP mm	t/LSP	A mm	S mm	F mm	Z mm	KxH mm	W mm	L mm	V mm	D mm	C mm	E mm	M kg	ISO Kl.
<b>2/1 Multi Pallet Handler - Type 6-52G-V</b>																
6-5204G-V	2000	600	4,5/600	1200	100	550-1930	1350	80x40	540	1150	735	40	492	910	1025	3 A
<b>3/2/1 Multi Pallet Handler - Type 6-53F-V</b>																
6-5304F-V	1200	600	4,5/600	1550	100	560-2340	150	60x50	500/560	1150	735	50	460	950	1180	3 A

**Notes:**

- Additional hydraulics required
- three for use of sideshift, extension and fork positioning function
- The unit has an integrated sideshift movement
- Equipped with high-quality bolt-on forks

**Options:**

- Other capacities, fork lengths and opening ranges.
- Solenoid valve
- Solenoid valve control kit (cable drum, push button, relay)