

Single scissor lift tables for evenly distributed loads

Model 1E

GREEN LINE

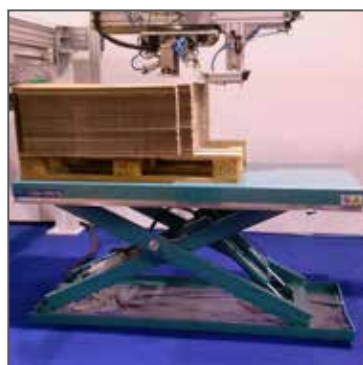

BOLZONI 

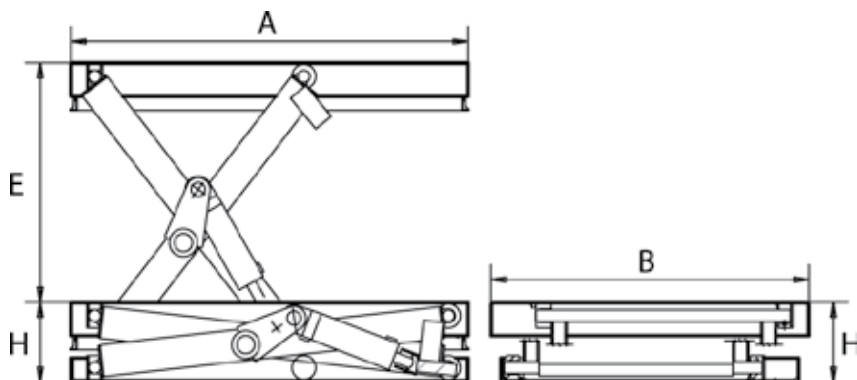

Range: 500 Kg - 2000 Kg

- Aluminium safety bar stops the descent of the platform in case of contact with obstructions
- Single acting hydraulic cylinders equipped with hose safety valve, check valve and drainage.
- Low voltage "Hold-to-run" type control box
- Mechanical locks for safe servicing and maintenance operations
- Removable lifting eye(s) to make easier handling and installation
- Compliance with the Machinery Directive 2006/42CE and Safety Requirements for lift tables EN1570-1.

Designed as a "work station" to provide improved ergonomic conditions to ensure the health, safety and comfort of the operator together with improved productivity. The ideal solution to keep the load at the right height in all kinds of industrial applications such as, assembly lines, packing operations etc...

Model	Capacity	Stroke	Platform	Collapsed Height	Motor	Cylinder
	kg	E mm	A x B mm	H mm	Kw	n. diam.
A1.05.E000	500	590	1000 x 800	200	0,55	1 60
A1.05.E010	500	800	1250 x 800	200	0,55	1 60
A1.05.E020	500	800	1250 x 1000	200	0,55	1 60
A1.05.E030	500	1000	1500 x 800	220	0,55	1 60
A1.05.E040	500	1000	1500 x 1000	220	0,55	1 60
A1.05.E050	500	1200	1800 x 800	240	0,75	1 60
A1.05.E060	500	1200	1800 x 1000	240	0,75	1 60
A1.10.E000	1000	590	1000 x 800	200	0,55	2 60
A1.10.E010	1000	800	1250 x 800	200	0,55	2 60
A1.10.E020	1000	800	1250 x 1000	200	0,55	2 60
A1.10.E030	1000	1000	1500 x 800	220	0,55	2 60
A1.10.E040	1000	1000	1500 x 1000	220	0,55	2 60
A1.10.E050	1000	1200	1800 x 800	240	0,75	2 60
A1.10.E060	1000	1200	1800 x 1000	240	0,75	2 60
A1.10.E070	1000	1600	2250 x 800	280	1,10	1 90
A1.10.E080	1000	1600	2250 x 1000	280	1,10	1 90
A1.15.E010	1500	800	1350 x 800	250	0,75	1 90
A1.15.E020	1500	800	1350 x 1000	250	0,75	1 90
A1.15.E030	1500	950	1500 x 800	260	0,75	1 90
A1.15.E040	1500	950	1500 x 1000	260	0,75	1 90
A1.15.E050	1500	1200	1800 x 800	270	1,10	1 90
A1.15.E060	1500	1200	1800 x 1000	270	1,10	1 90
A1.20.E010	2000	800	1350 x 800	250	1,10	1 110
A1.20.E020	2000	800	1350 x 1000	250	1,10	1 110
A1.20.E030	2000	950	1500 x 800	260	1,10	1 110
A1.20.E040	2000	950	1500 x 1000	260	1,10	1 110
A1.20.E050	2000	1200	1800 x 800	270	1,10	1 110
A1.20.E060	2000	1200	1800 x 1000	270	1,10	1 110

CUSTOMIZED SOLUTIONS

Thanks to our experience and a wide range of accessories available, we are able to provide customized solutions to improve productivity, efficiency and safety to suit all specific requirements.

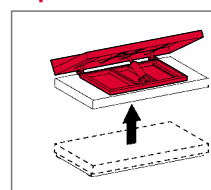

Tilting top platform 35°

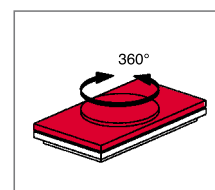

Manual circular turntable

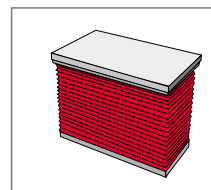

PVC bellow

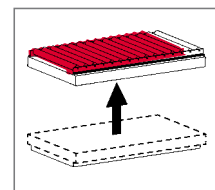

Gravity roller conveyor

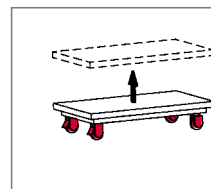

Lower frame on wheels (to move the table without the load)

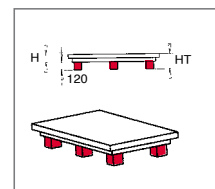

Lower frame with fork pockets

Bolzoni promotes environmental sustainable research and innovation.

For a lower impact on the environment, Bolzoni lift tables are available with biodegradable hydraulic oil on request, and are all provided with high-efficiency electric motors IE3. Lift tables are painted with water based nontoxic solvent free paint.

Bolzoni SpA lift tables facility is certified with the Environment Certificate ISO 14001:2015, since 2006.

BOLZONI S.p.A.

VIA I MAGGIO,103 - CASONI DI PODENZANO -
29027 PIACENZA (ITALIA)

Tel. +39 0523 55 55 11 - Fax +39 0523 52 40 87

www.bolzonigroup.com - sales@bolzonigroup.com