

# BOLZONI

G R O U P



## Notes:

- Two hydraulic functions required.
- E = arm thickness at the tip, including rubber.
- T – arm thickness at the arm middle, including rubber, 57mm for all models.
- Load backrest.
- Pressure relief valve.
- Flow divider..
- Integral side shift.

## Carton Clamp – Side Shifting

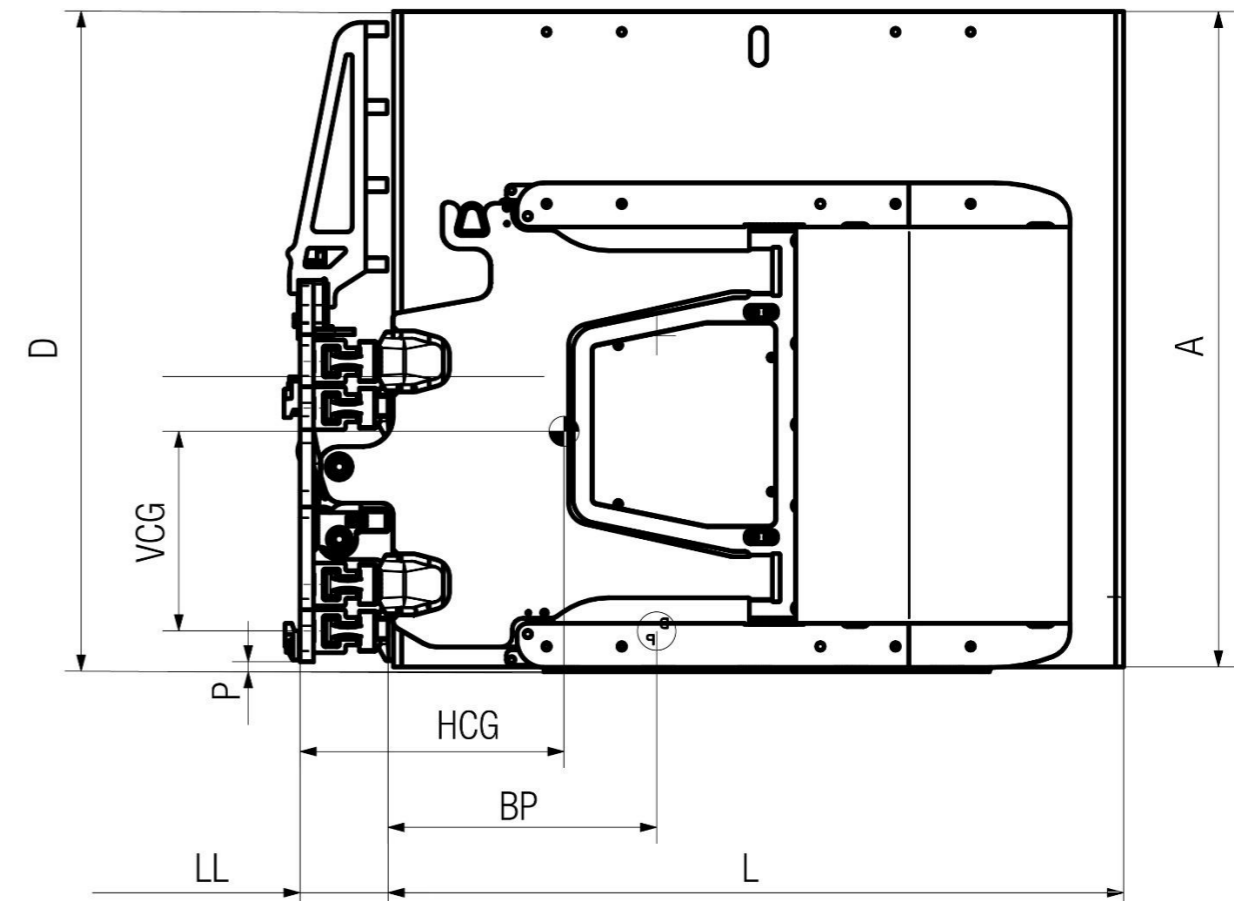
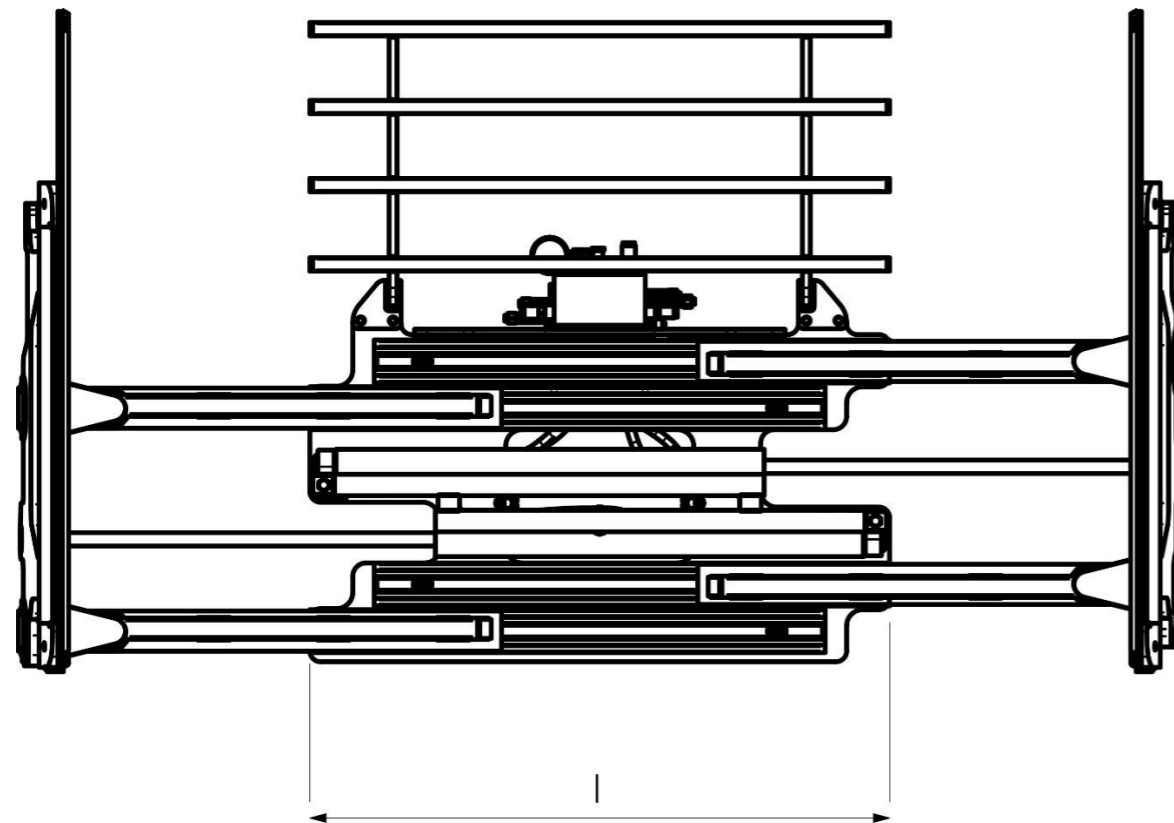

Model	Code	Capacity	Load Centre	Opening range	Frame Width	Weight	Mounting Class
		Q kg	BP mm	B mm	I mm	W kg	ISO 2328
LC 12 C5A	54-197	1200	610	540-1970	1100	763	II A
6 C7A	57-228	1600	685	570-2280	1370	866	II A