



REAR LOWER ARM FRAME GUARD

INSTALL

BRONCO RAPTOR (2022 +)

**** IT IS HIGHLY RECOMMENDED THIS PRODUCT IS INSTALLED BY A CERTIFIED MECHANIC ****

LEVEL: DIFFICULT

PAGE 2

HARDWARE ASSEMBLY KEY & DIAGRAM

PAGE 3

DRIVERS SIDE DIAGRAM
(WITH ASSEMBLY NOTES)

PAGE 4

PASSENGER SIDE DIAGRAM
(WITH ASSEMBLY NOTES)

PAGE 5

INSTALLATION - DRIVERS SIDE

PAGE 6 - 8

INSTALLATION - PASSENGER SIDE



REAR LOWER ARM FRAME GUARD

INSTALL

BRONCO RAPTOR (2022 +)

PAGE 2 - HARDWARE ASSEMBLY & DIAGRAM

ITEM NO.	PART NUMBER	DESCRIPTION	QTY.
1	FMI 2022 Bronco Raptor rear frame lower arm mount - main skid plate Driver Side		1
2	FMI 2022 Bronco Raptor rear frame lower arm mount - bottom plastic slider		1
3	90566A029	1/4-20 - Grade 5 - Steel Thin Nylon-Insert Locknut	16
4	92210A540	1/4-20 x 3/4 long - 18-8 Stainless Steel Hex Drive Flat Head Screw	16
5	FMI 2022 Bronco Raptor rear frame lower arm mount - inside welded nut plate - Drivers Side - working assy		1
6	FMI 2022 Bronco Raptor rear frame lower arm mount - outside welded nut plate - Drivers Side - working assy		1
7	92620A583	5/16 - 18 x 1" long - Grade 8 - Zinc Yellow-Chromate Plated Hex Head Screw	5
8	98023A030	5/16 - Grade 8 - SAE Washer - Zinc Yellow-Chromate Plated Grade 8 Steel Washer	5
9	MirrorFMI 2022 Bronco Raptor rear frame lower arm mount - main skid plate Driver Side2		1
10	MirrorFMI 2022 Bronco Raptor rear frame lower arm mount - bottom plastic slider1		1
11	94407A105	5/16-18 - Black -18-8 Stainless Steel Nylon-Insert Locknut	1

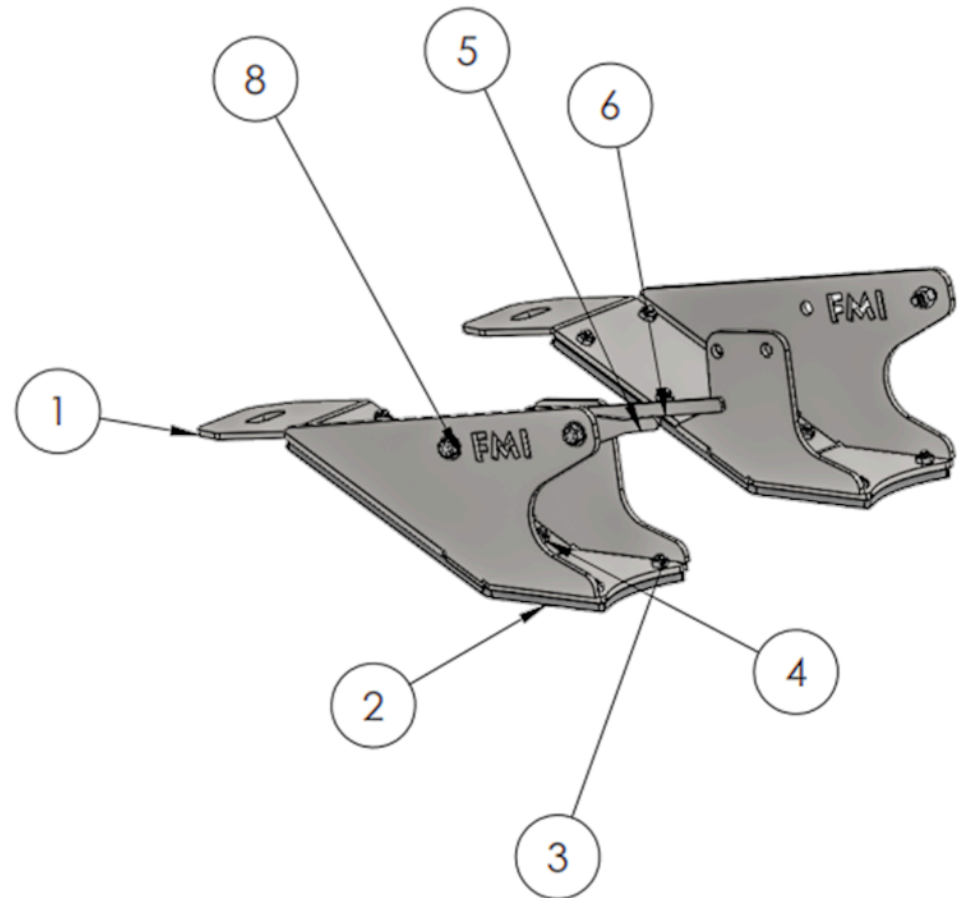



REAR LOWER ARM FRAME GUARD

INSTALL

BRONCO RAPTOR (2022 +)

PAGE 3 - DRIVER SIDE DIAGRAM (with assembly notes)

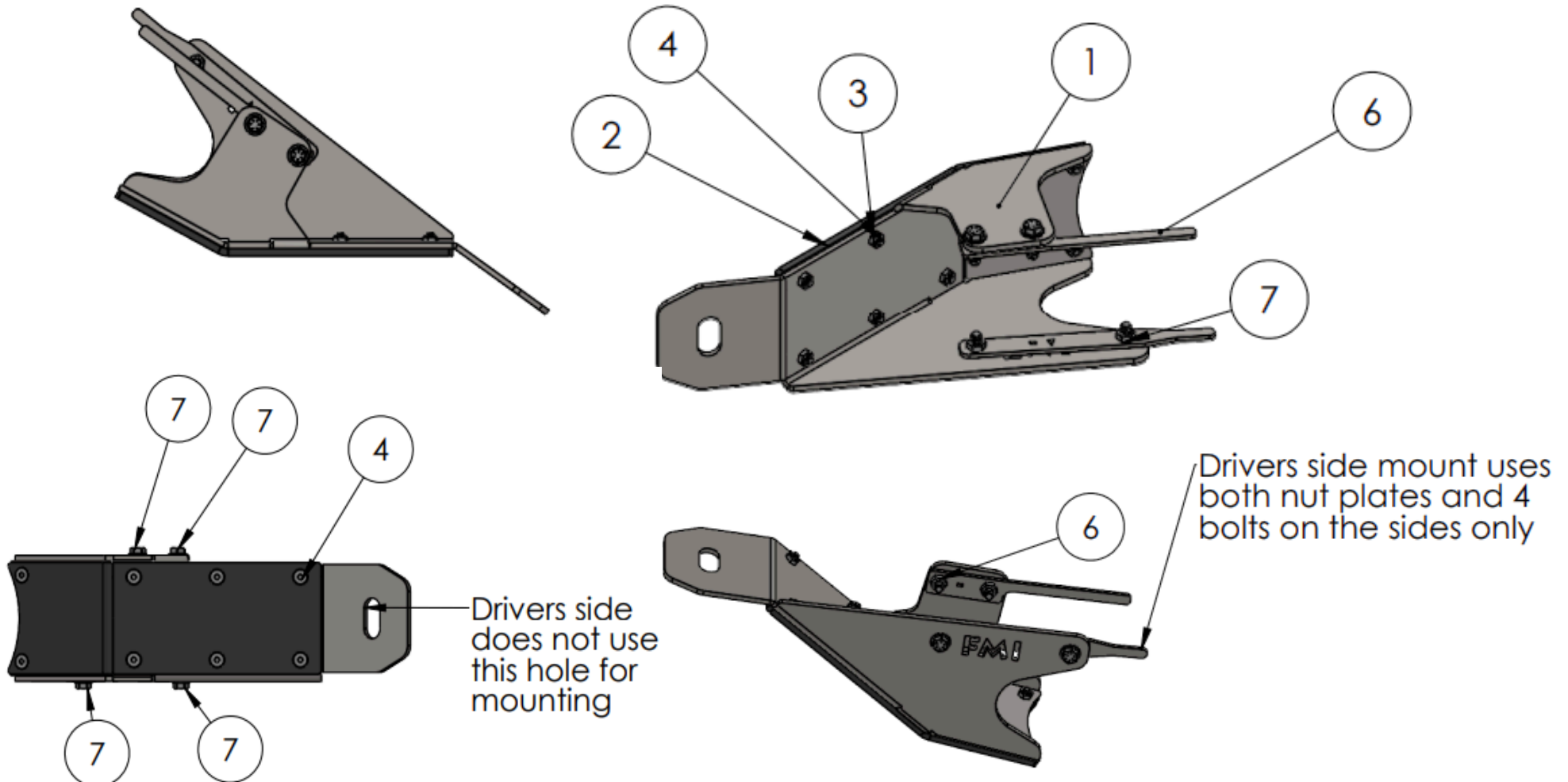



REAR LOWER ARM FRAME GUARD

INSTALL

BRONCO RAPTOR (2022 +)

PAGE 4 - PASSENGER SIDE DIAGRAM (with assembly notes)

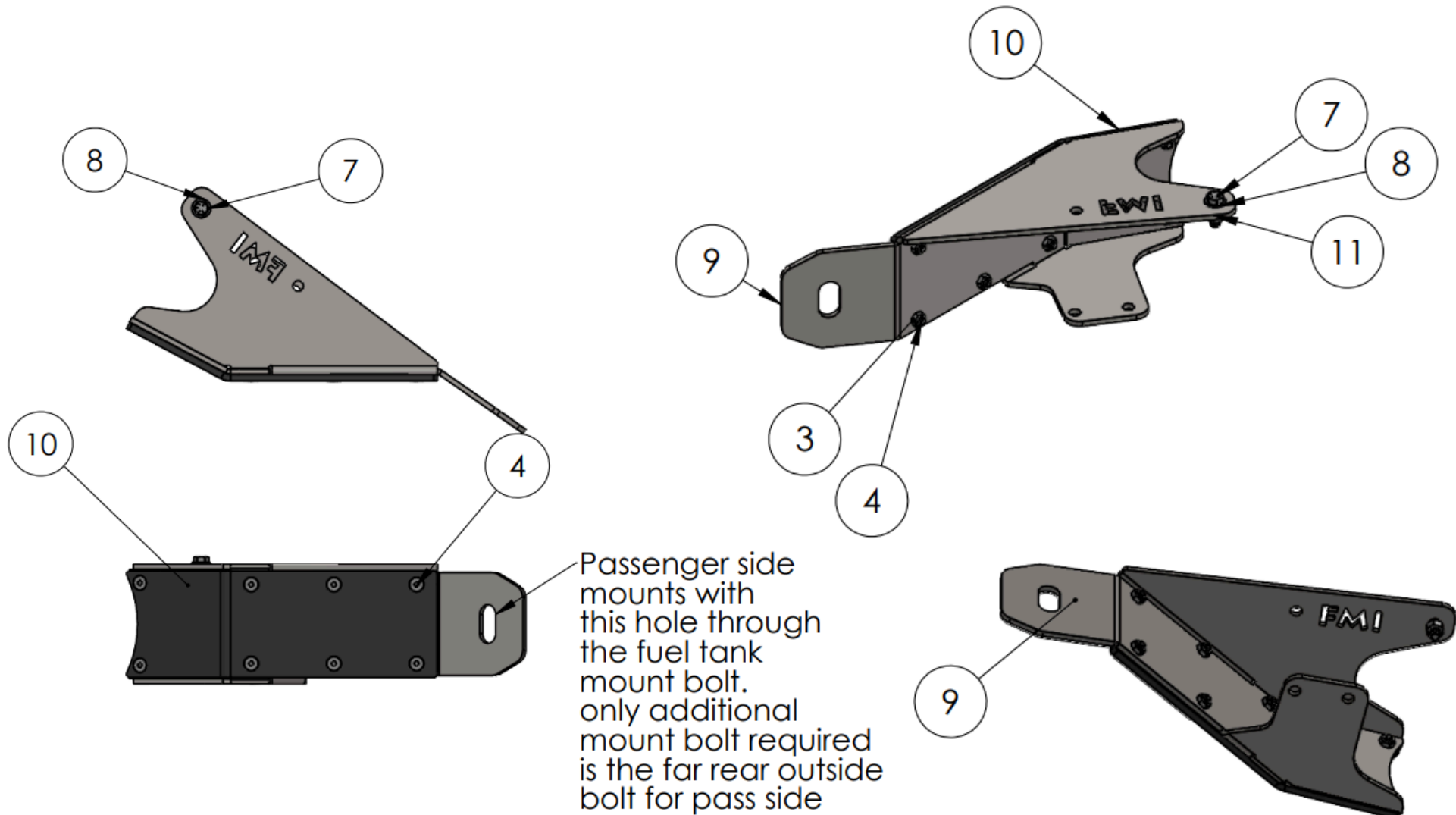



REAR LOWER ARM FRAME GUARD

INSTALL

BRONCO RAPTOR (2022 +)

PAGE 5 - INSTALLATION / DRIVERS SIDE

Step 1

Starting on the driver's side, remove the nut on the link at the frame. The bolt doesn't need to be completely removed, just only pushed out enough to rotate the flag retainer outside of its hole (the hole is needed to secure the guard)

The flag will rest against the mount itself out of the way of the link and the guard.

Step 2

With the flag out of the way, position the guard over the link mount and install the supplied spacers between the guard and the frame.

Then install the supplied nut plates inside the pocket, securing the guard to the mount with the supplied hardware.

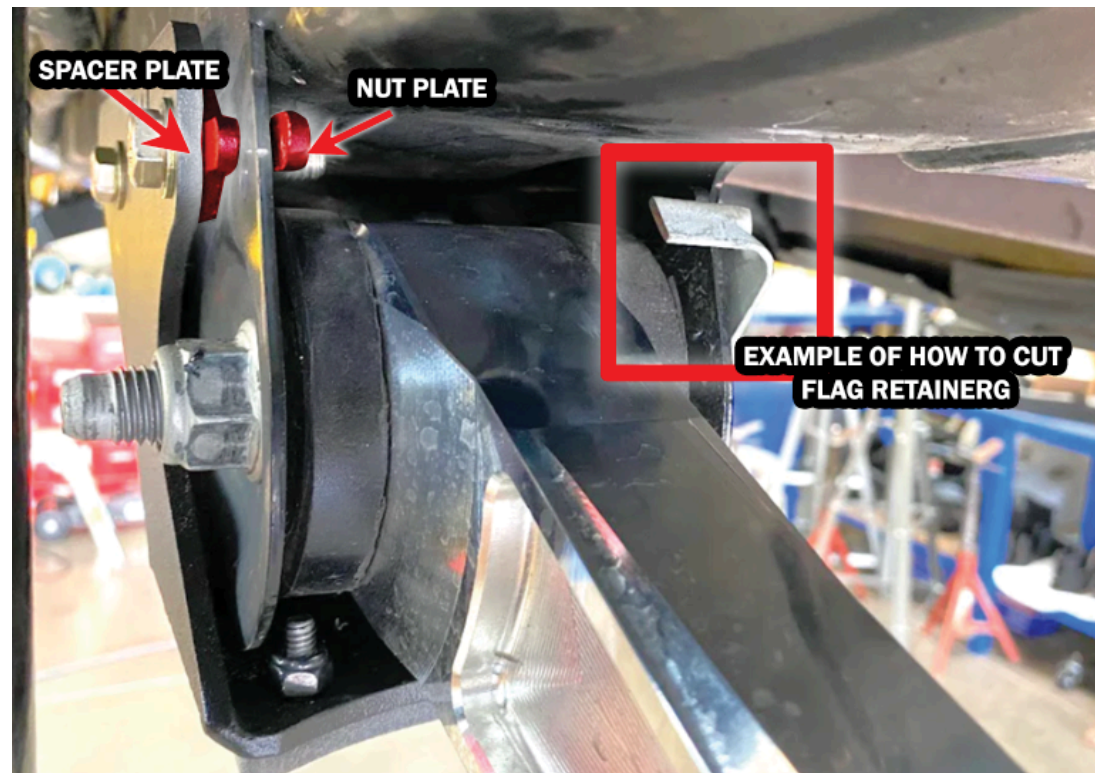



REAR LOWER ARM FRAME GUARD

INSTALL

BRONCO RAPTOR (2022 +)

PAGE 6 - INSTALLATION / PASSENGER SIDE

Step 3

On the passenger side on the inside of the frame rail, there is a cover that covers the head of the bolt that needs to be removed - this can be done using a small ratchet and a t25 torx bit (the lower the profile the easier it is)

The gas tank does not need to be removed.

Step 4

Once the guard has been removed, repeat the same procedure from step 1.

The tail on the retaining flag is too long for it to be completely removed without removing the gas tank. We recommend pushing the bolt out as far as possible so it is touching the gas tank, then cut the flag off flush with the outside of the link mount.

DO NOT CUT THE BOLT.

Once the tail has been cut, the bolt can be rotated out of the way for clearance for the link guard.



REAR LOWER ARM FRAME GUARD

INSTALL

BRONCO RAPTOR (2022 +)

PAGE 7 - INSTALLATION / PASSENGER SIDE (cont.)

Step 5

If equipped with a stock gas tank skid, remove the bolt directly in front of the link mount and loosen the bolt behind the link mount. Then loosen the other two bolts in front of the bolt that was removed.

Step 6

The link guard can now be installed. The guard will slide underneath the tab on the gas tank skid and reuse the factory bolt. Leave loose at this time. Then install the supplied spacers and nut tabs the same way it was done on the drivers side in step 2

The nut tab and spacer are not required to be installed on the inside of the frame rail due to the clearance with the gas tank.

(It can be done to add extra strength, but it is not required on the passenger side)





REAR LOWER ARM FRAME GUARD

INSTALL

BRONCO RAPTOR (2022 +)

PAGE 8 - INSTALLATION / PASSENGER SIDE (cont.)

Step 7

Tighten down all the hardware and retighten the gas tank skid bolts to factory specs.

Step 8

Enjoy your new lower rear link guards! Be sure to tag us in photos or videos on Facebook & Instagram the next time you off-road with this product installed.

@FoutzMotorsports
#FoutzMotorsports

